

Assembly Instructions

Caution: You must read this before you proceed

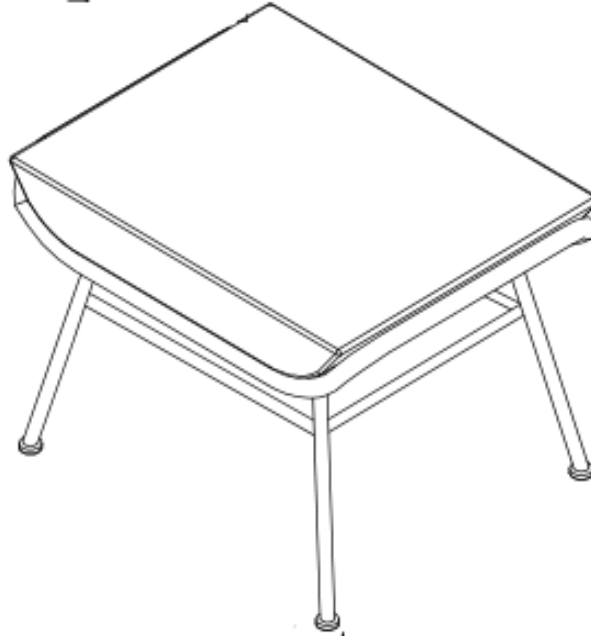



Stool



Part List

Label	Picture	Description	QTY
A	A line drawing of a square seat panel. It has a grid of slats and rounded corners. The drawing is a perspective view from the front-left.	Seat Panel	1
B	A line drawing of the stool's frame. It shows four legs and a square base structure. The drawing is a perspective view from the front-left.	Stool Legs	1
C	A line drawing of a square seat cushion. It has rounded corners and a simple rectangular shape. The drawing is a perspective view from the front-left.	Seat Cushion	1

Hardware

Label	Picture	Description	QTY
①		Bolt (M6X20mm)	5
②		Washer	5
③		Cap	5
④		Allen Key	1

Assembly Preparation

Before
Beginning
Assembly:

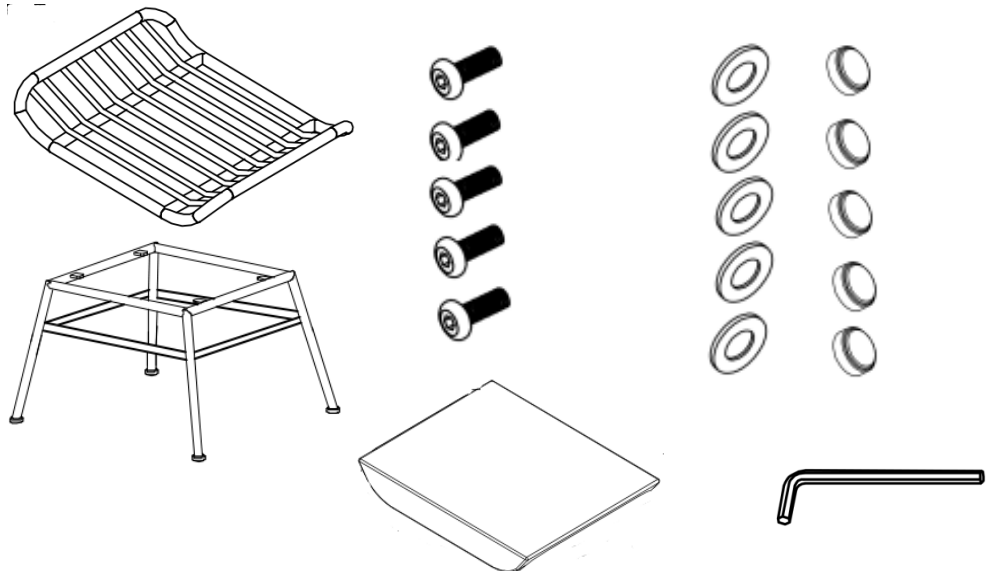

- Read instructions, cover to cover-



- Have 2 adults on hand for assembly-



- Do not assemble on flooring or carpet-



- Assemble on a clean non-marring surface (packing foam)-



- Save all packaging until finished-

Assembly Steps

Overview

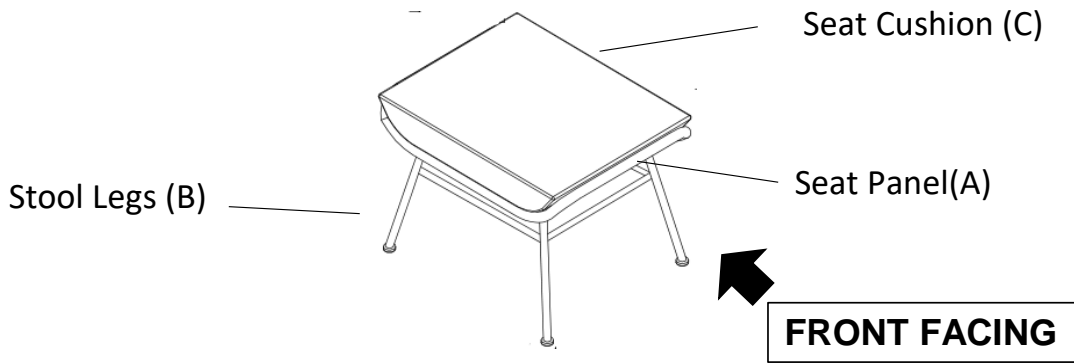

This Stool has multiple parts and may require up to 30 minutes to assemble. To give you an overview of the the Stool parts, the above picture is to help you put the various parts into perspective. Please read through the instructions below to familiarise yourself with the parts and steps before assembly.

Step 1

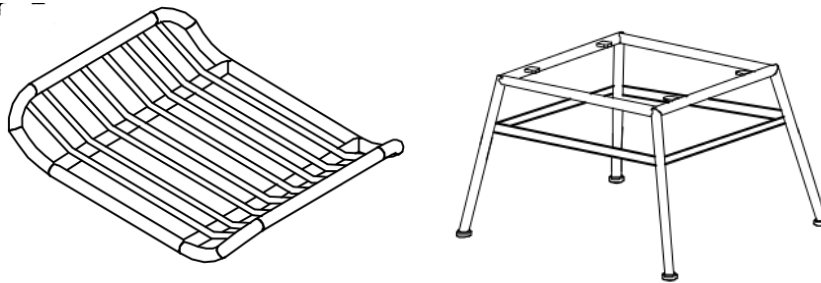

Unpack and place all parts on a clean, non-marring surface.

Step 2

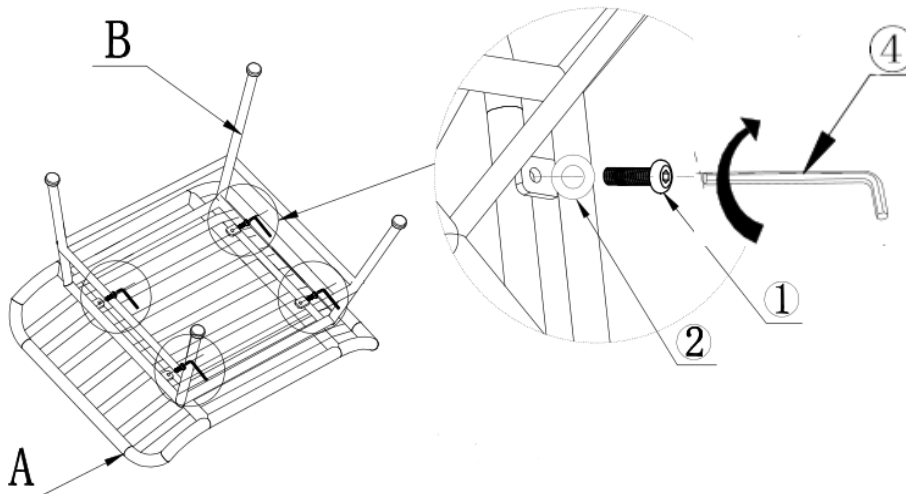

Place the Seat Panel(A) facedown onto a clean, non-marring surface.
Align the Seat Panel(A) to Stool Legs(B) as shown above.
Attach Seat Panel(A) to Stool Legs(B) using Bolts(①) and Washers(②) with Allen Key(④).
Do not fully tighten the Bolts.

Step 3



Stand the Stool up.

Exert pressure floorwards, onto the chair with both your hands.

This pressure will help the Legs and chair Top reach full alignment status.

Check for wobbles on a LEVEL surface.

If no wobbles are found proceed to tighten the Bolts in a sequential manner, until evenly secured.

When tightening the Bolts tighten sequentially.

Do not tighten any Bolt fully and then move on towards the next one.

If there are still wobbles, loosen the Bolts and execute the same above process.

If the Stool is not Stable it could lead to damage to the product.

Step 4

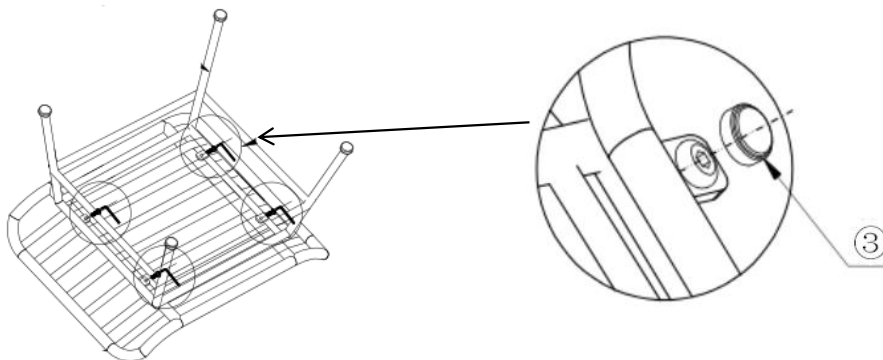

Turn over the Stool.

Cover the Bolts(①) with Caps(③) by hand.

Step 5

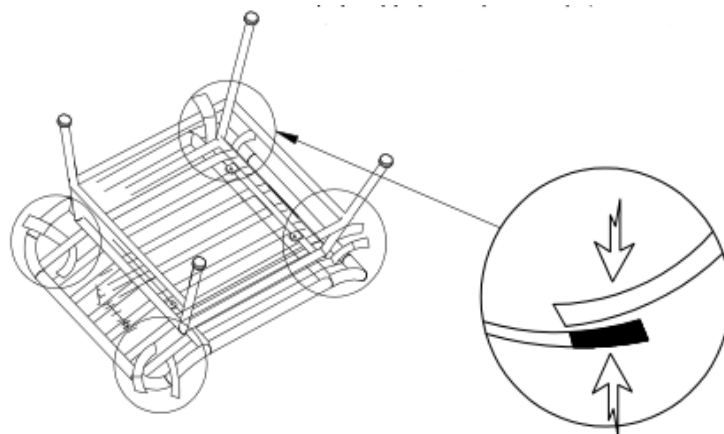

Stand the Stool up.

Put the Seat Cushion(C) onto the Stool.

Secure the Seat Cushion using the Velco straps as pictured.



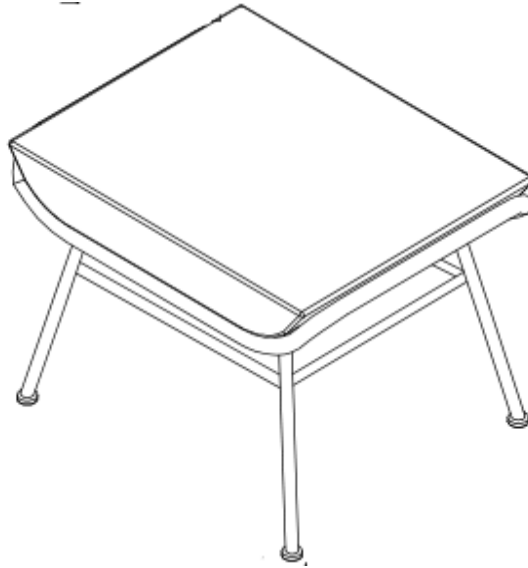

















Step 6



Your Stool is ready for use.

This Stool can only be used on a flat and level surface.

Care & Maintenance

-   ● Do not put hot items directly on furniture surface
 -   ● Do not clean furniture with harsh cleansers or polish.
 -   ● To obtain the longest lifespan of your outdoor products, minimizing exposure to direct sunlight is recommended.
 -   ● Children should not climb or jump on the furniture.
 -   ● Do not write on furniture without a padded barrier to protect the surface.
 -   ● To obtain the longest lifespan of your outdoor products, avoid extended and lengthy exposure to rain, snow, and direct sunshine. Whenever possible cover the product and /or place under patio or awnings.
 -   ● Not for commercial use. For residential use only .
 -   ● Stains may be removed with mild soap solution and damp cloth.
 -   ● Keep away from sources of ignition.
-
-   ● Dust and pick-up spills using a clean, non-colored, lint-free cloth.