

---

# Instruction

---

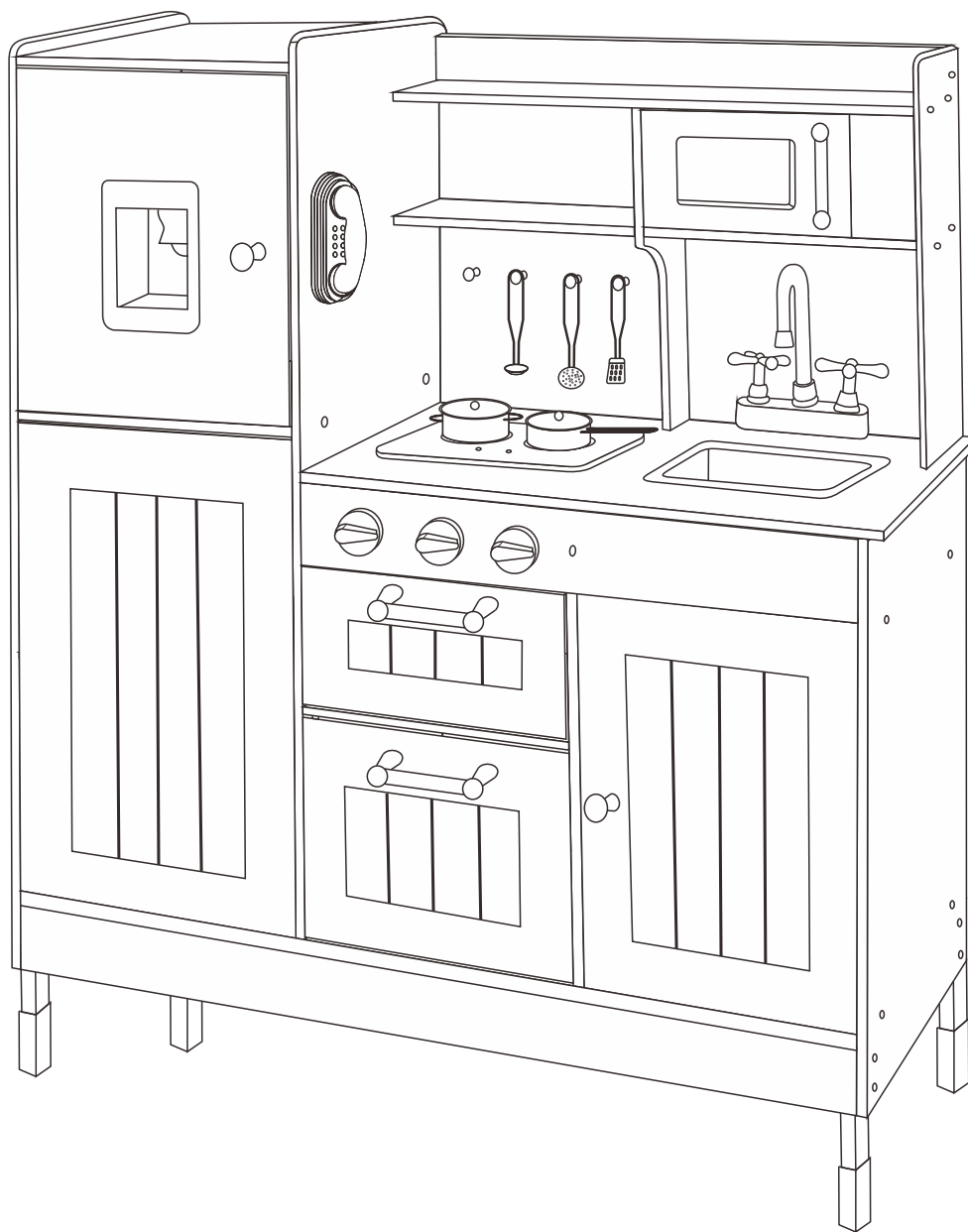

NATURE INTERNATIONAL TRADING INC.  
597 BEAVER CREEK CT, BRIGHTON, CO  
80601

Email Add: [tfservices@163.com](mailto:tfservices@163.com)

## **USER'S MANUAL**

---

**Kids Kitchen toy  
ETD041**

### **KEEP INSTRUCTIONS FOR FUTURE USE**

Read all instructions before assembling and using the product.

Never use this product if any parts are missing, damaged, or broken. Contact seller for replacement parts and instructional literature if needed. Never substitute parts.

# Before You Start

Please read all instructions carefully and keep it for future reference.

## General Security Warning

**Caution:** The Product is not suitable for the children under 3 years

**Danger:** Keep all small parts and packaging materials for this product away from babies and children, otherwise they may pose a choking hazard.

**Danger:** Lack of attachment may cause a risk of tipping.



**WARNING:**

**CHOKING HAZARD**-Small parts. Not for children under 3 years.



# **Warning for Assembly**

- ⚠ Must be assembled by an adult**
- ⚠ Remove all Packaging, separate and count all parts and hardware.**
- ⚠ Read through each step carefully and follow the proper order.**
- ⚠ We recommend that, where possible, all items are assembled near to the area in which they will be placed in use, to avoid moving the product unnecessarily once assembled.**
- ⚠ Ensure a secure surface during construction, and place the product always on a flat, steady and stable surface**
- ⚠ Do not mix old and new batteries.**
- ⚠ Do not mix alkaline, standard (carbon-zinc), or rechargeable batteries**

**IMPORTANT INFORMATION:**

1. Before installing, please refer to the manual to check each part.

2. If you experience any issue during the installation, please reach out to our service team

for assistance: [tfsservices@163.com](mailto:tfsservices@163.com)

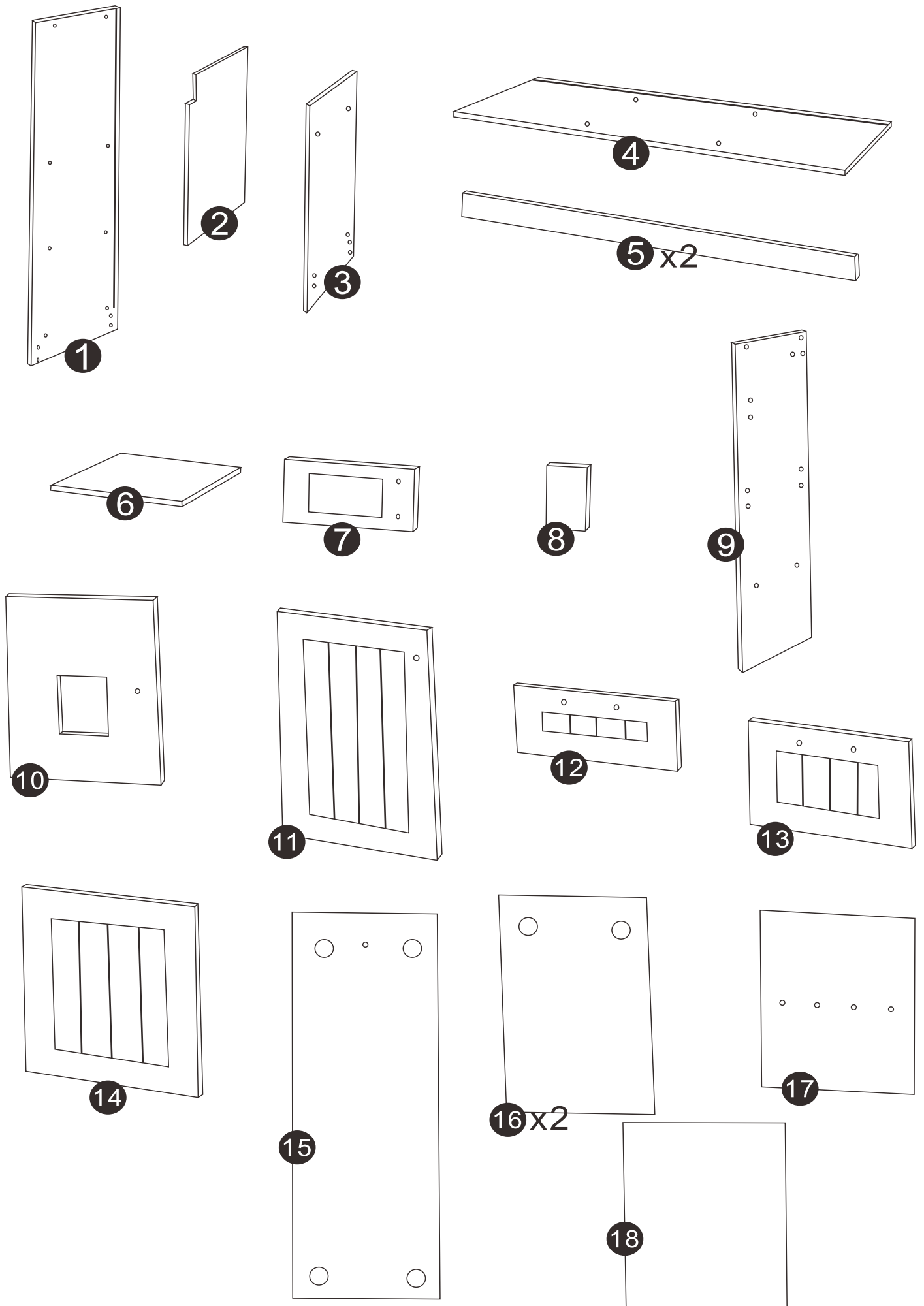

**IMPORTANT INFORMATION:**

1. Before installing, please refer to the manual to check each part.
2. If you experience any issue during the installation, please reach out to our service team for assistance: [tfservices@163.com](mailto:tfservices@163.com)

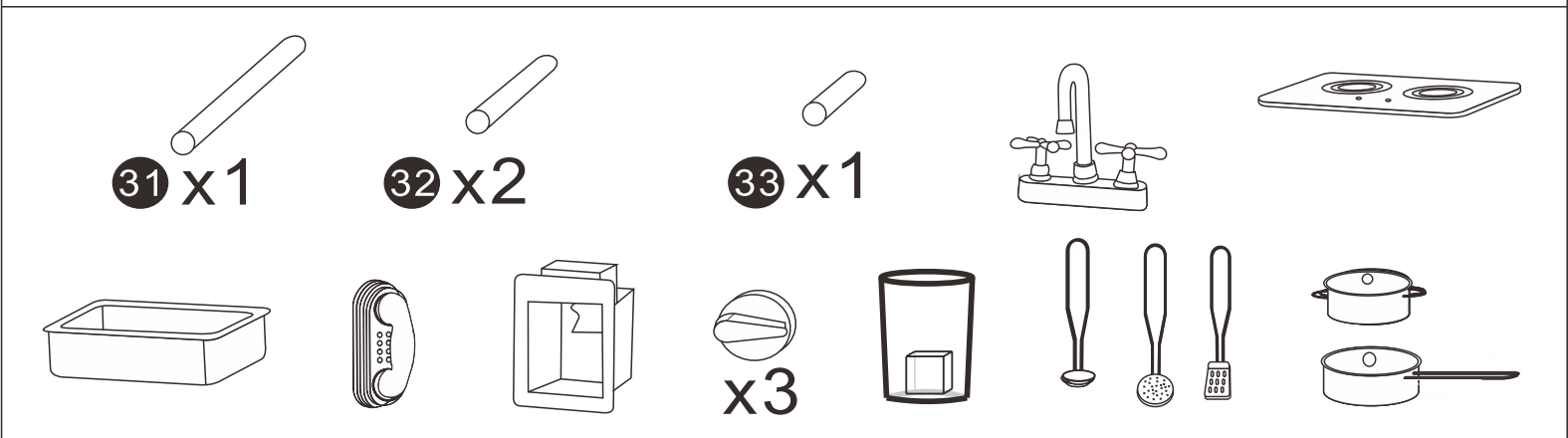
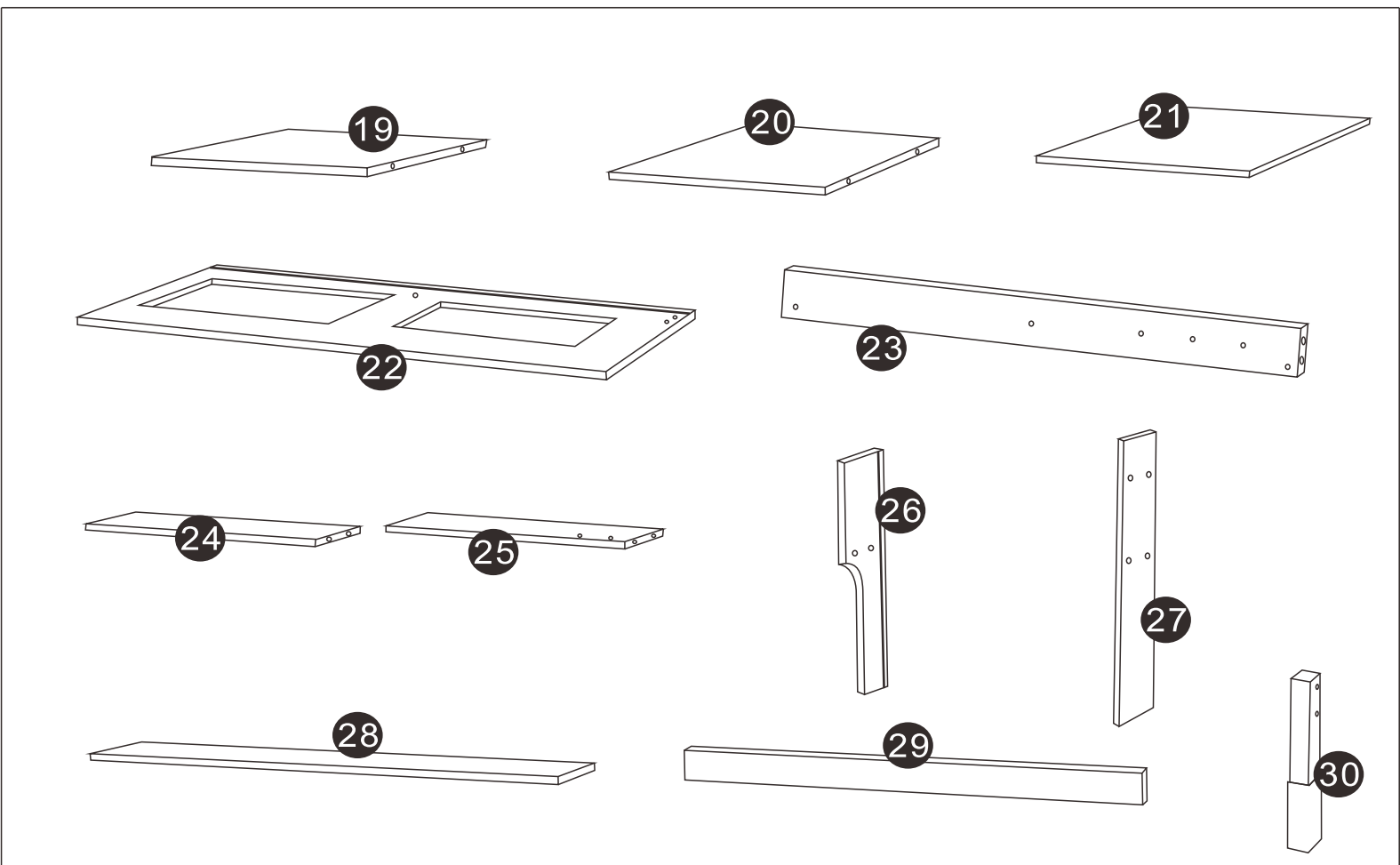

**IMPORTANT INFORMATION:**

1. Before installing, please refer to the manual to check each part.
2. If you experience any issue during the installation, please reach out to our service team for assistance: [tfsservices@163.com](mailto:tfsservices@163.com)

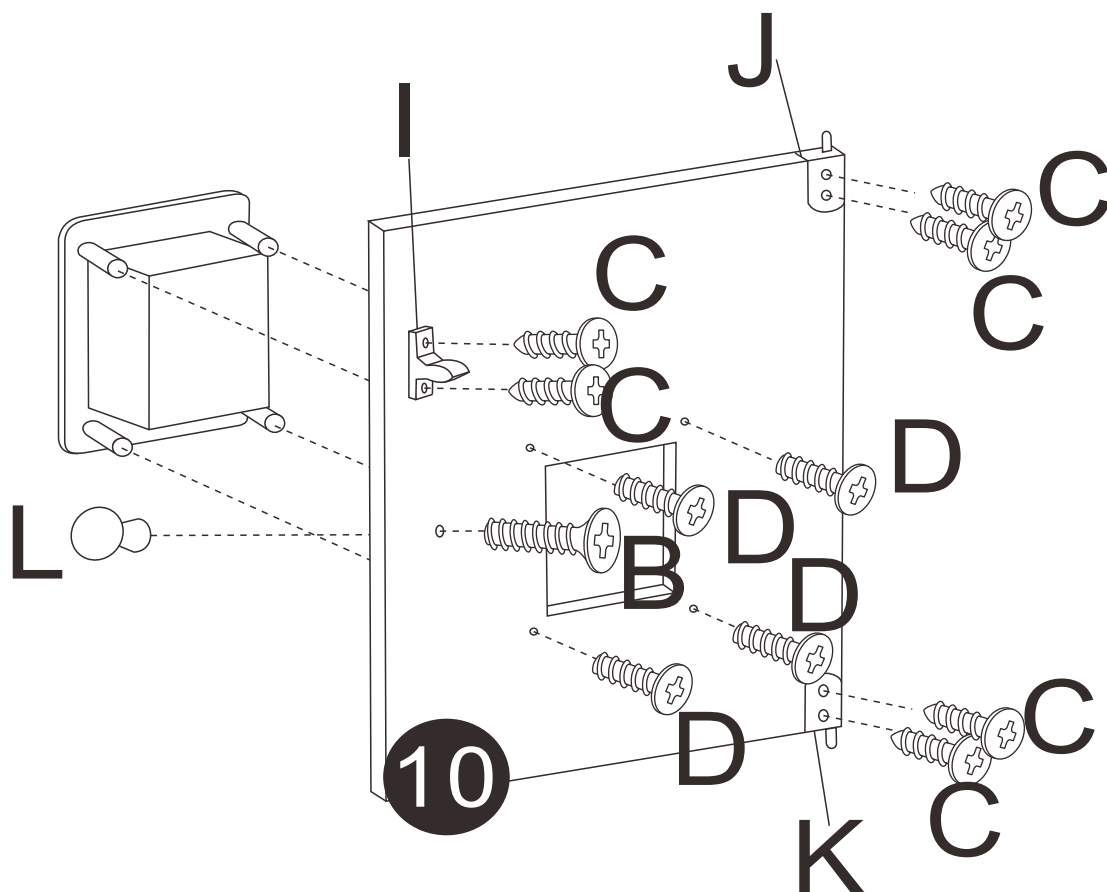

- Bx1
- Cx6
- Dx4
- Kx1
- Lx1
- I x1
- J x1

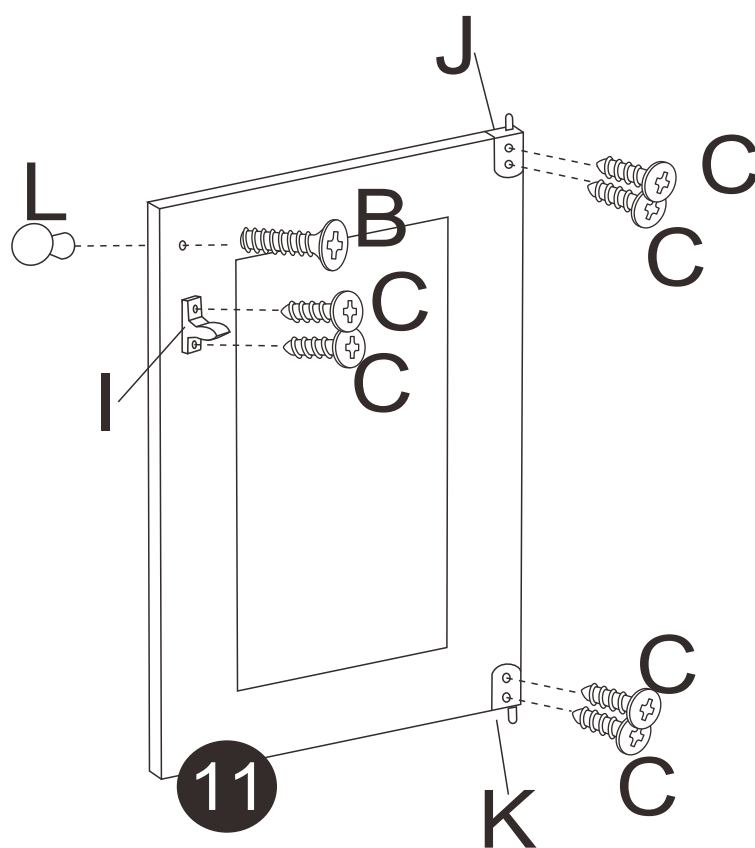

- Bx1
- Cx6
- Kx1
- Lx1
- I x1
- J x1

**IMPORTANT INFORMATION:**

1. Before installing, please refer to the manual to check each part.
2. If you experience any issue during the installation, please reach out to our service team for assistance: [tfsservices@163.com](mailto:tfsservices@163.com)

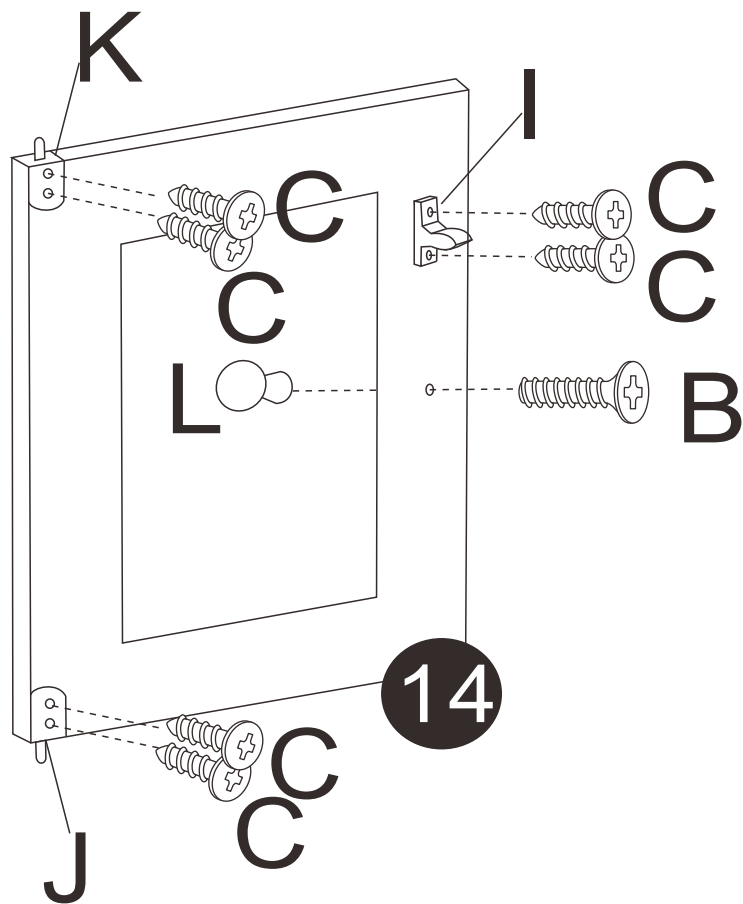

- Bx1
- Cx6
- Kx1
- Lx1
- I x1
- Jx1

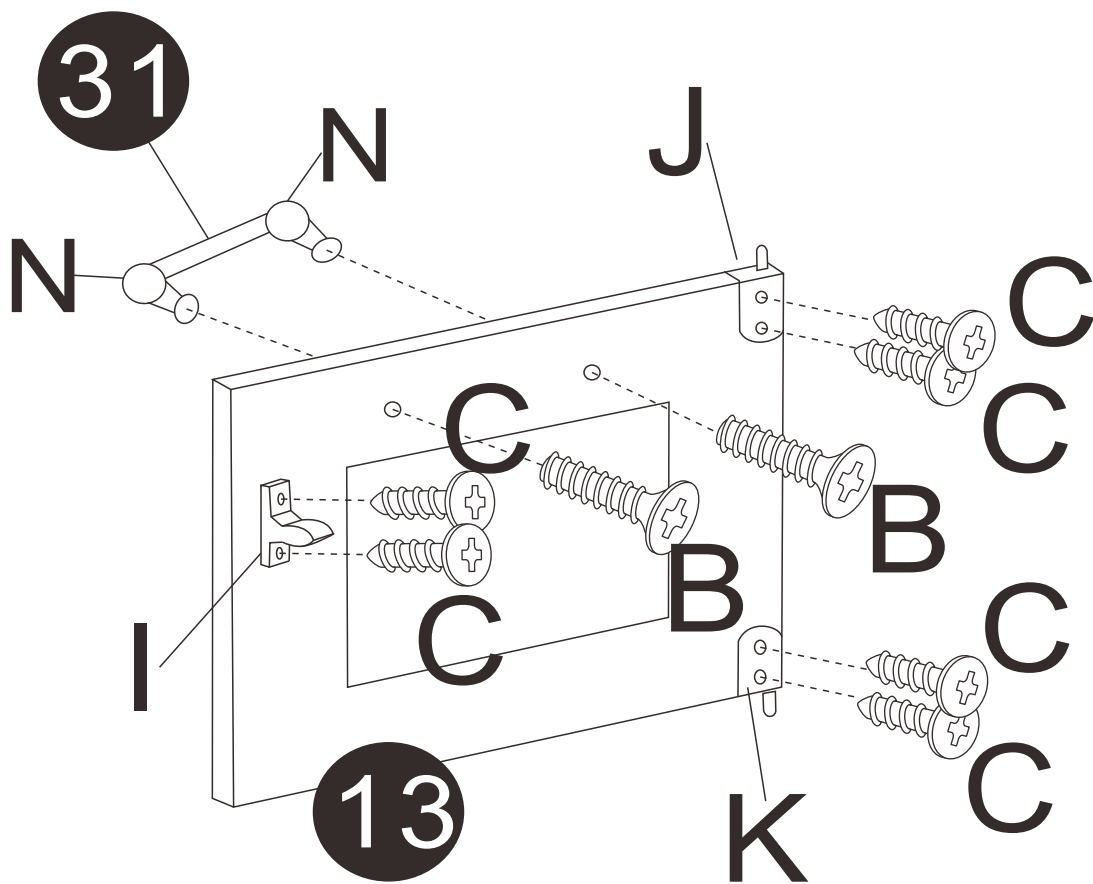

- Bx2
- Cx6
- Kx1
- I x1
- Nx2
- Jx1

**IMPORTANT INFORMATION:**

1. Before installing, please refer to the manual to check each part.
2. If you experience any issue during the installation, please reach out to our service team for assistance: [tfsservices@163.com](mailto:tfsservices@163.com)

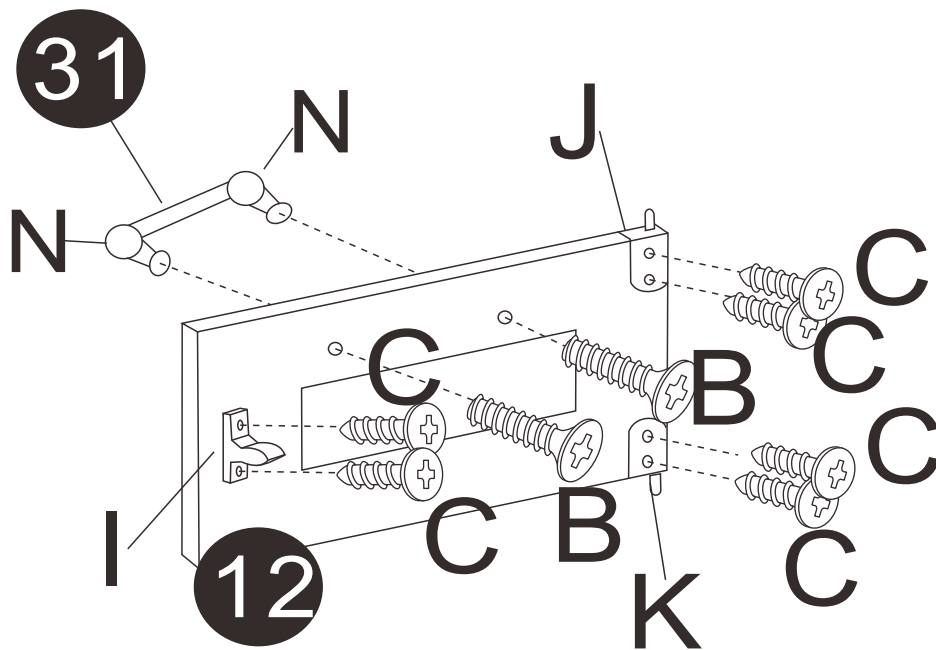

Bx2  
Cx6  
Kx1  
Nx2  
Jx1  
I x1

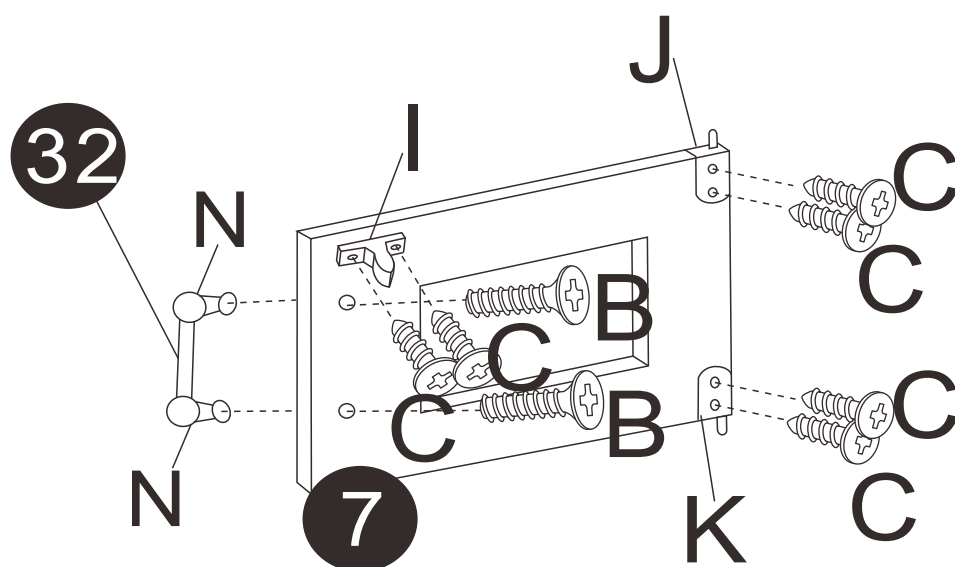

Bx2  
Cx6  
Kx1  
Nx2  
Jx1  
I x1

**IMPORTANT INFORMATION:**

1. Before installing, please refer to the manual to check each part.
2. If you experience any issue during the installation, please reach out to our service team for assistance: [tfservices@163.com](mailto:tfservices@163.com)

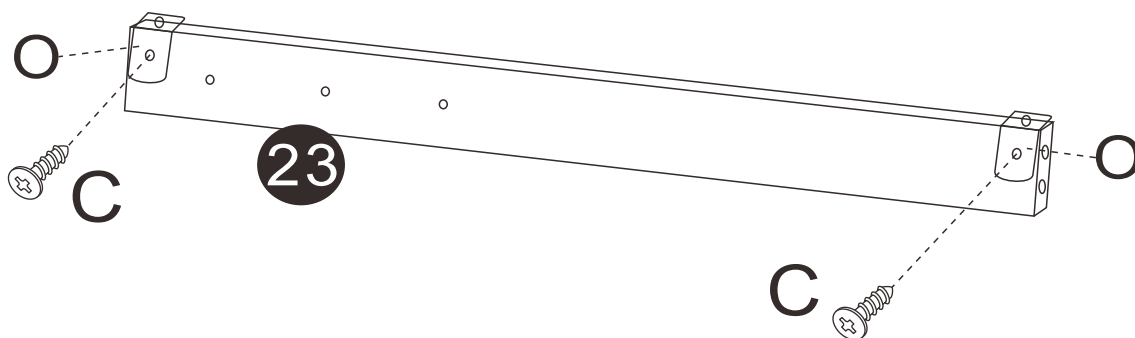

Cx2  
Ox2

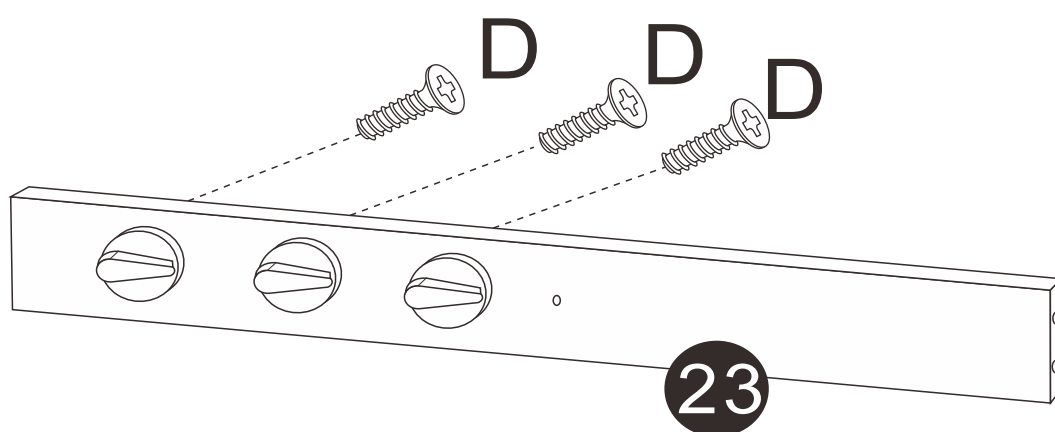

Dx3  
x3

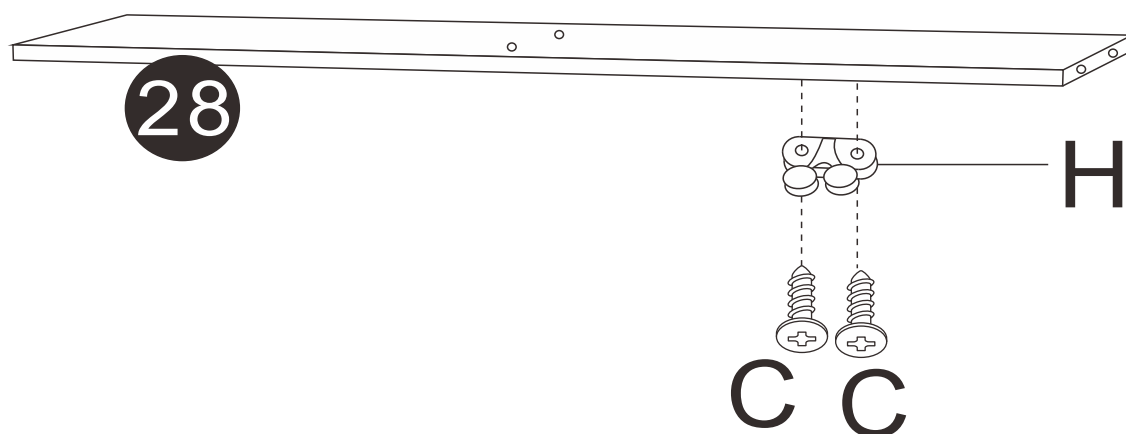

Cx2  
Hx1

**IMPORTANT INFORMATION:**

- 1. Before installing, please refer to the manual to check each part.
- 2. If you experience any issue during the installation, please reach out to our service team for assistance: [tfservices@163.com](mailto:tfservices@163.com)

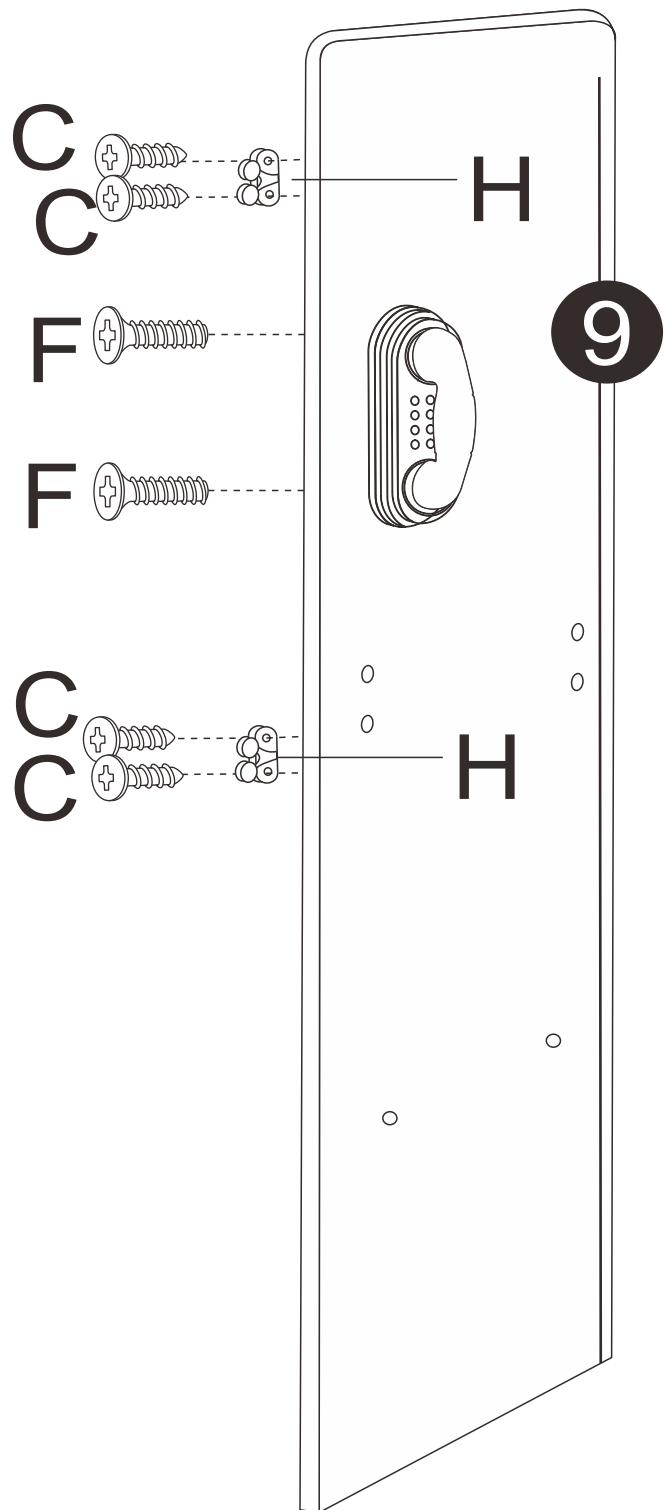

Cx4  
Fx2  
Hx2

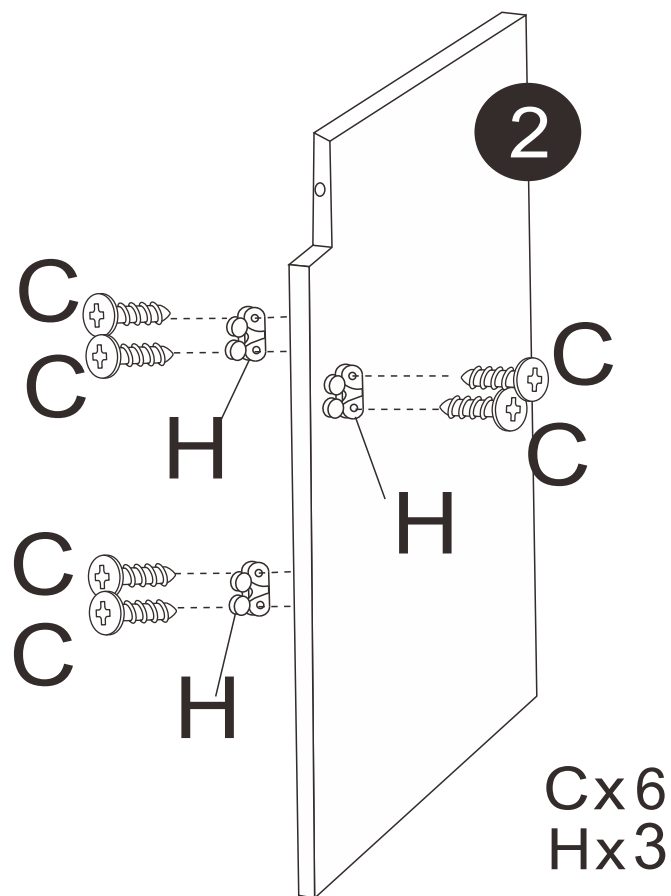

Cx6  
Hx3

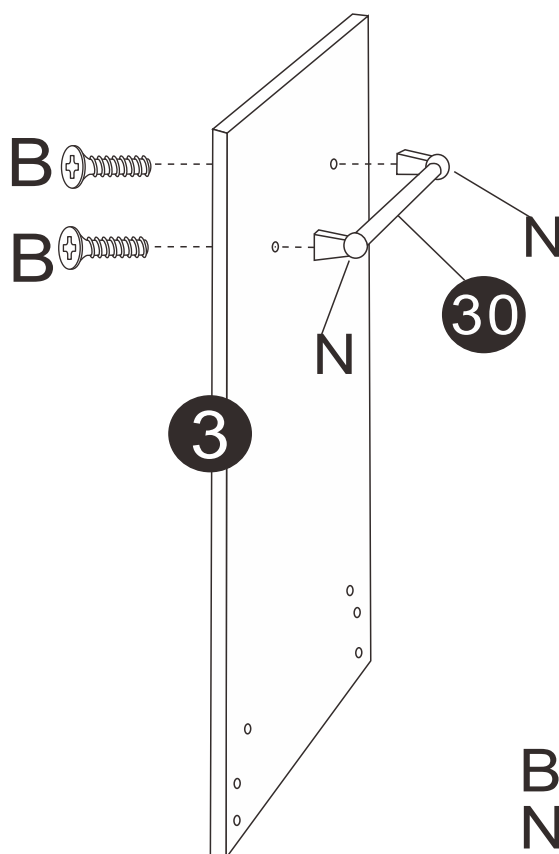

Bx2  
Nx2

**IMPORTANT INFORMATION:**

1. Before installing, please refer to the manual to check each part.
2. If you experience any issue during the installation, please reach out to our service team for assistance: [tfsservices@163.com](mailto:tfsservices@163.com)

**1**

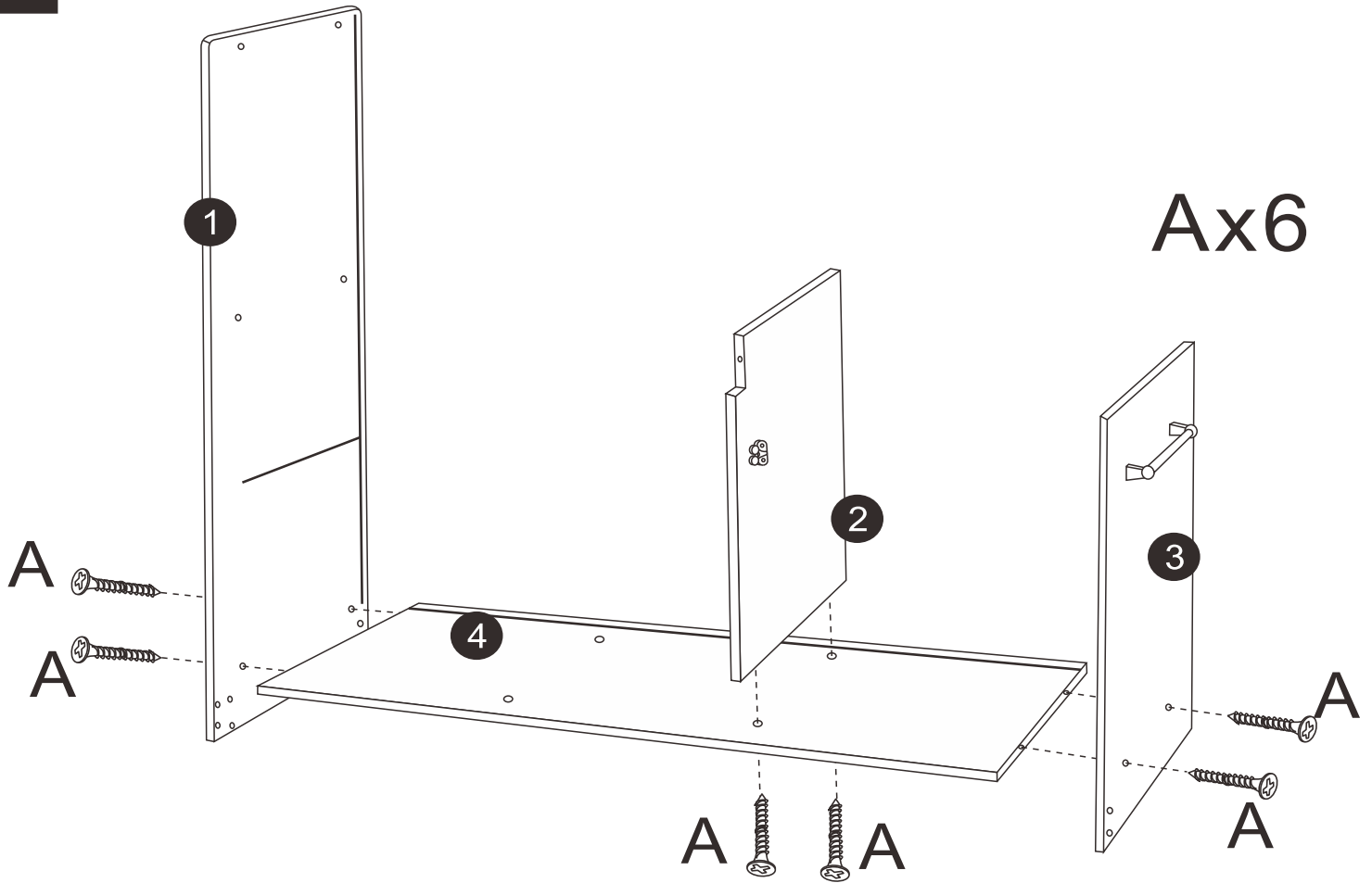

**2**

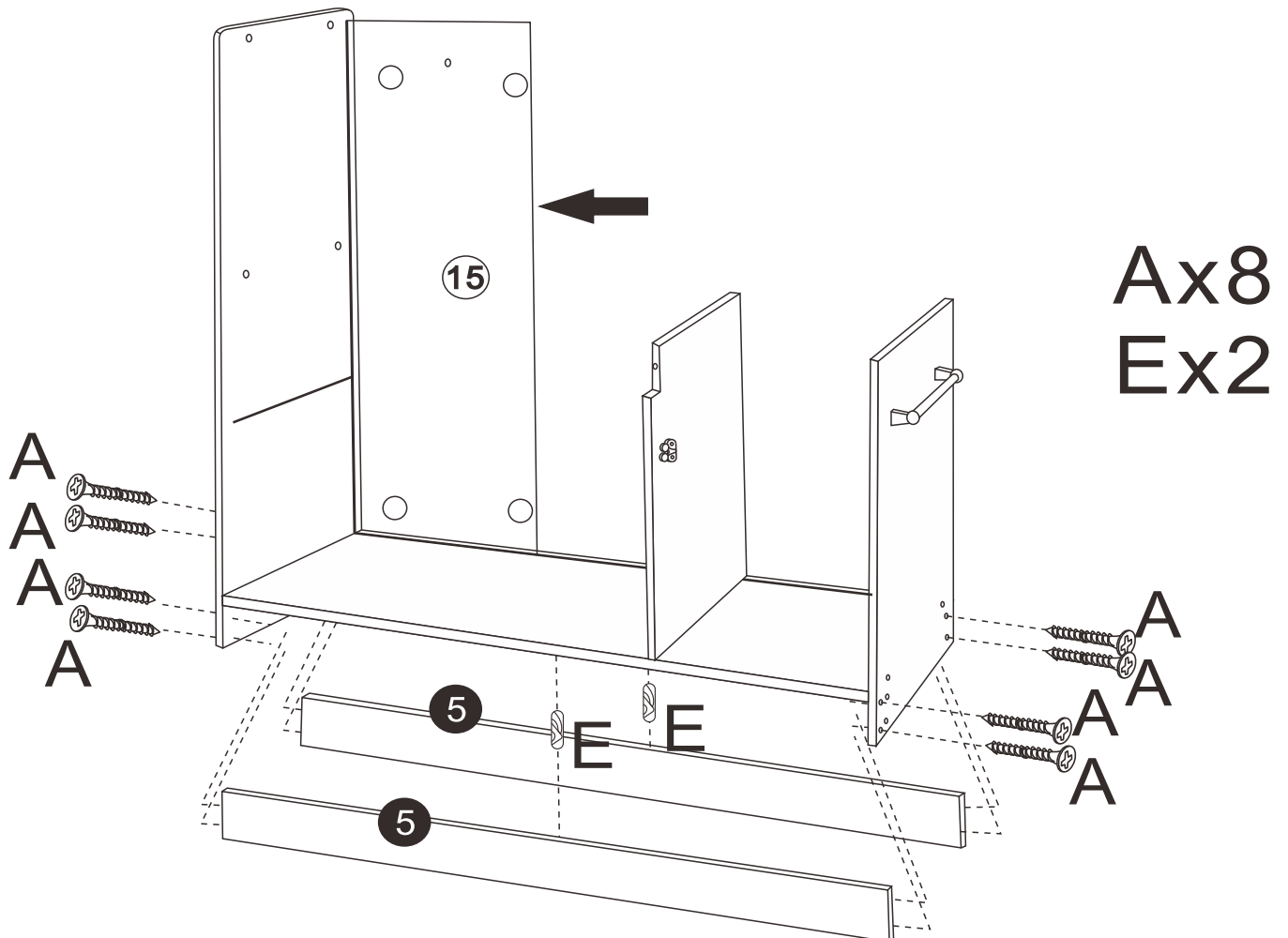

**IMPORTANT INFORMATION:**

1. Before installing, please refer to the manual to check each part.
2. If you experience any issue during the installation, please reach out to our service team for assistance: [tfservices@163.com](mailto:tfservices@163.com)

**3**

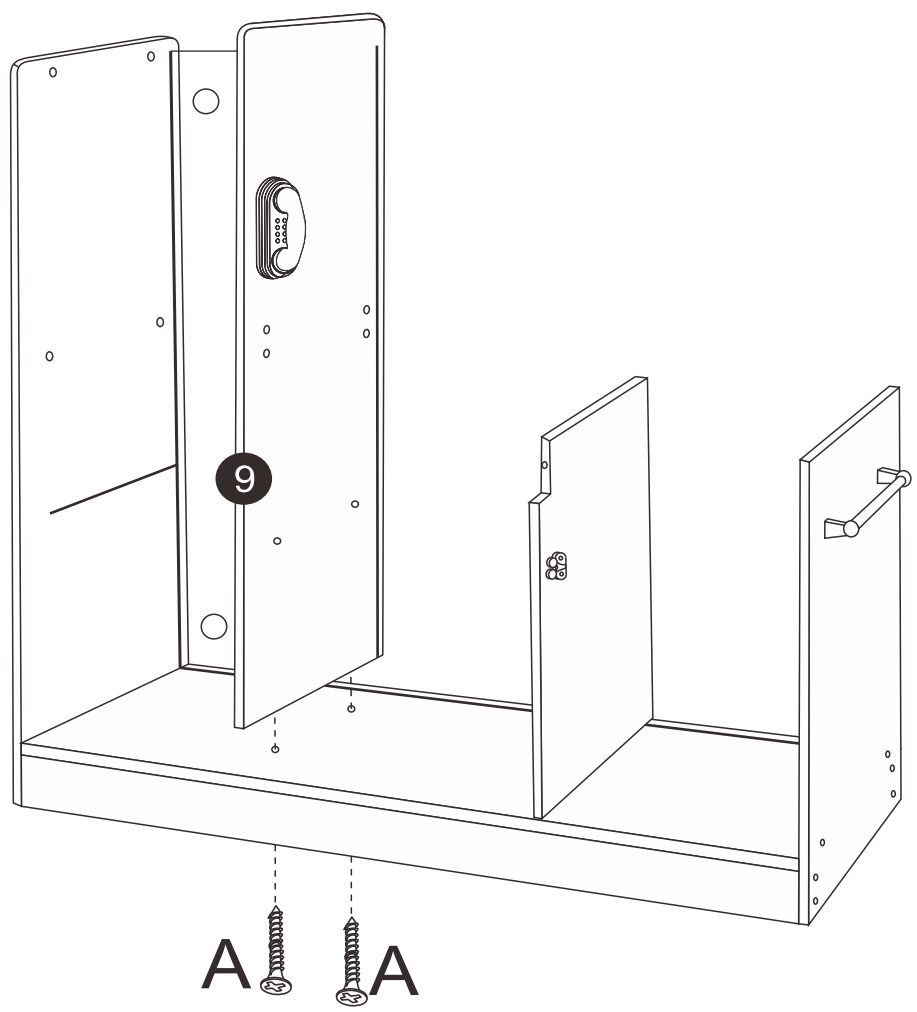

**Ax2**

**4**

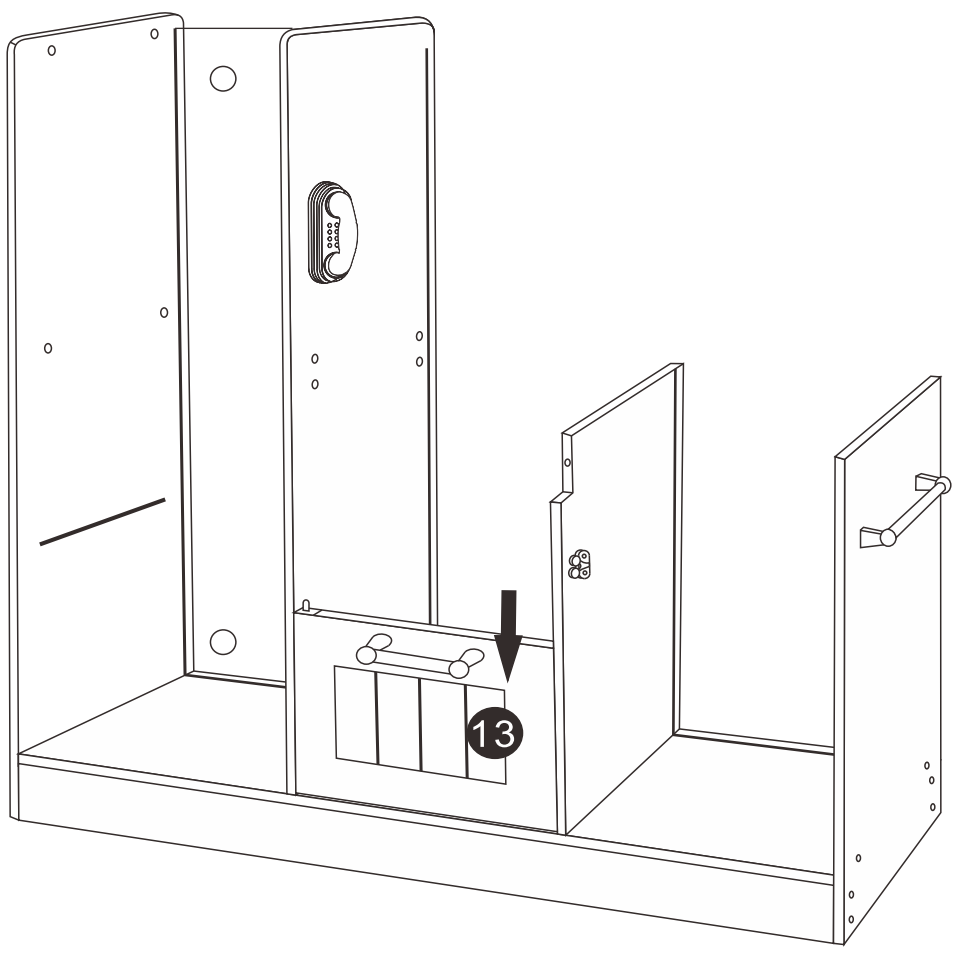

**IMPORTANT INFORMATION:**

1. Before installing, please refer to the manual to check each part.
2. If you experience any issue during the installation, please reach out to our service team for assistance: [tfservices@163.com](mailto:tfservices@163.com)

**5**

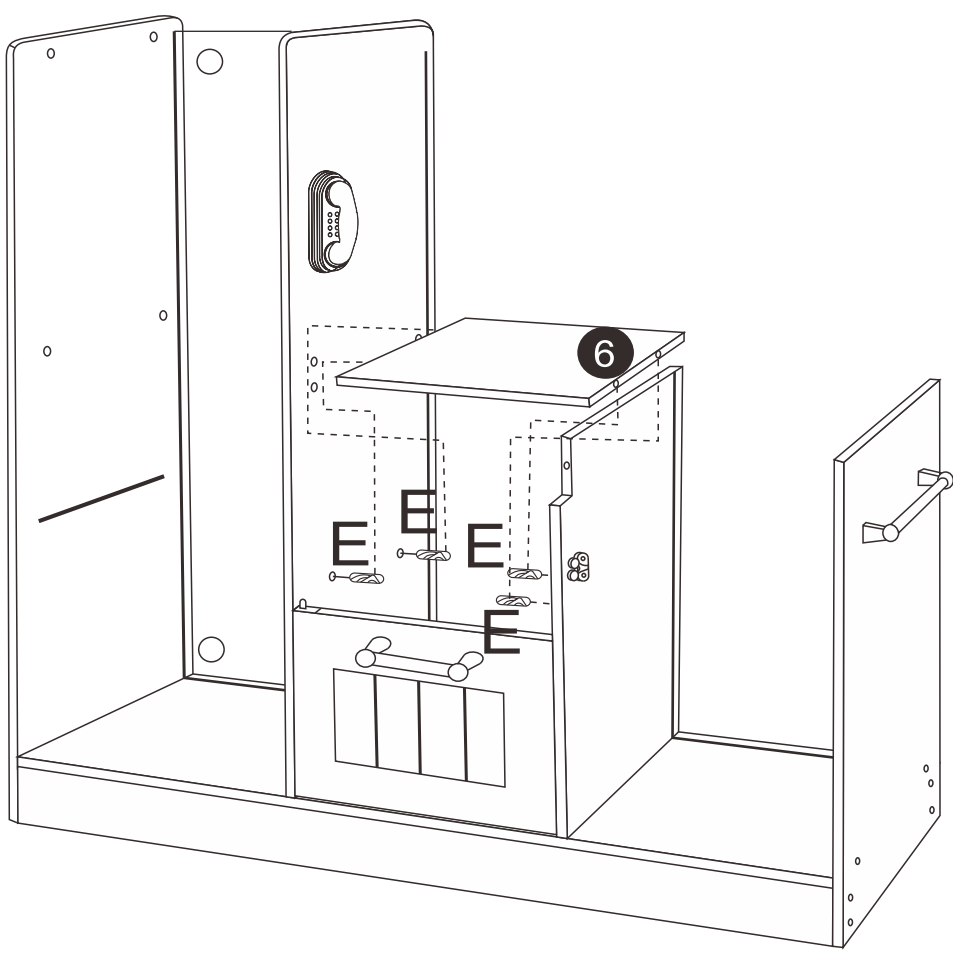

**Ex4**

**6**

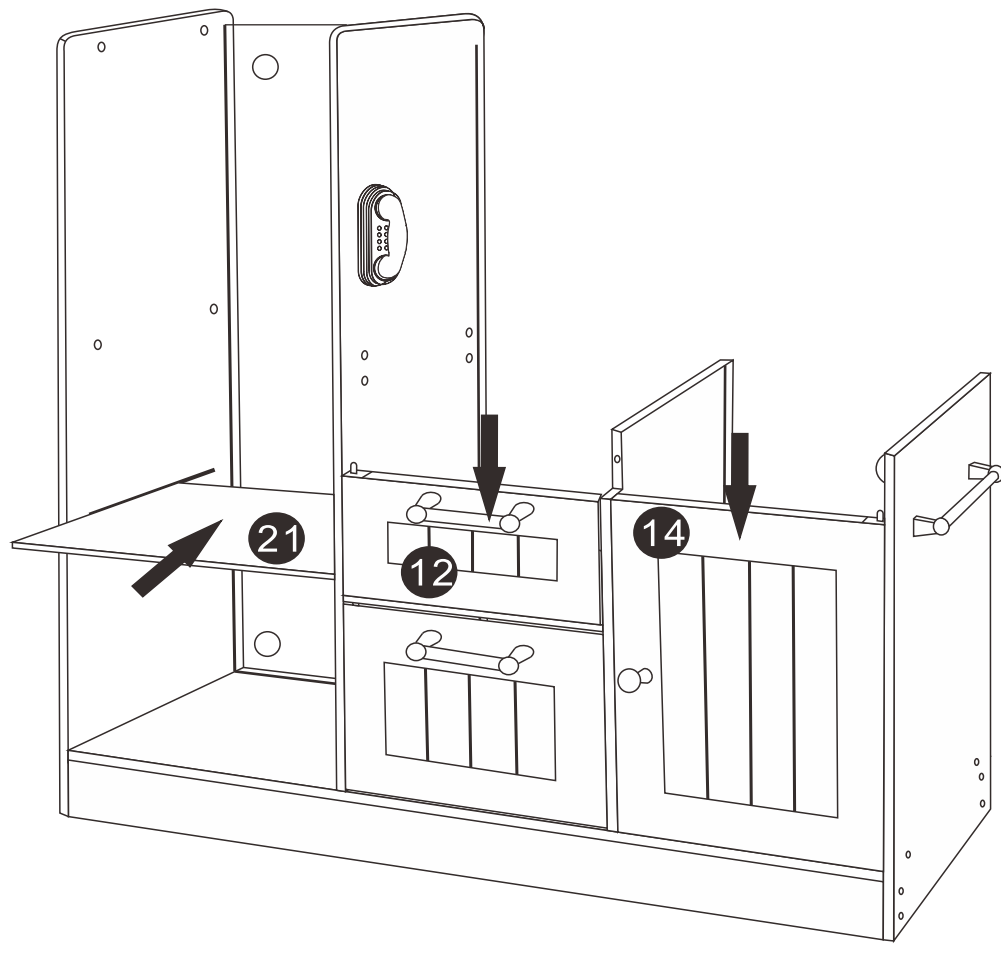

**IMPORTANT INFORMATION:**

1. Before installing, please refer to the manual to check each part.
2. If you experience any issue during the installation, please reach out to our service team for assistance: [tfservices@163.com](mailto:tfservices@163.com)

**7**

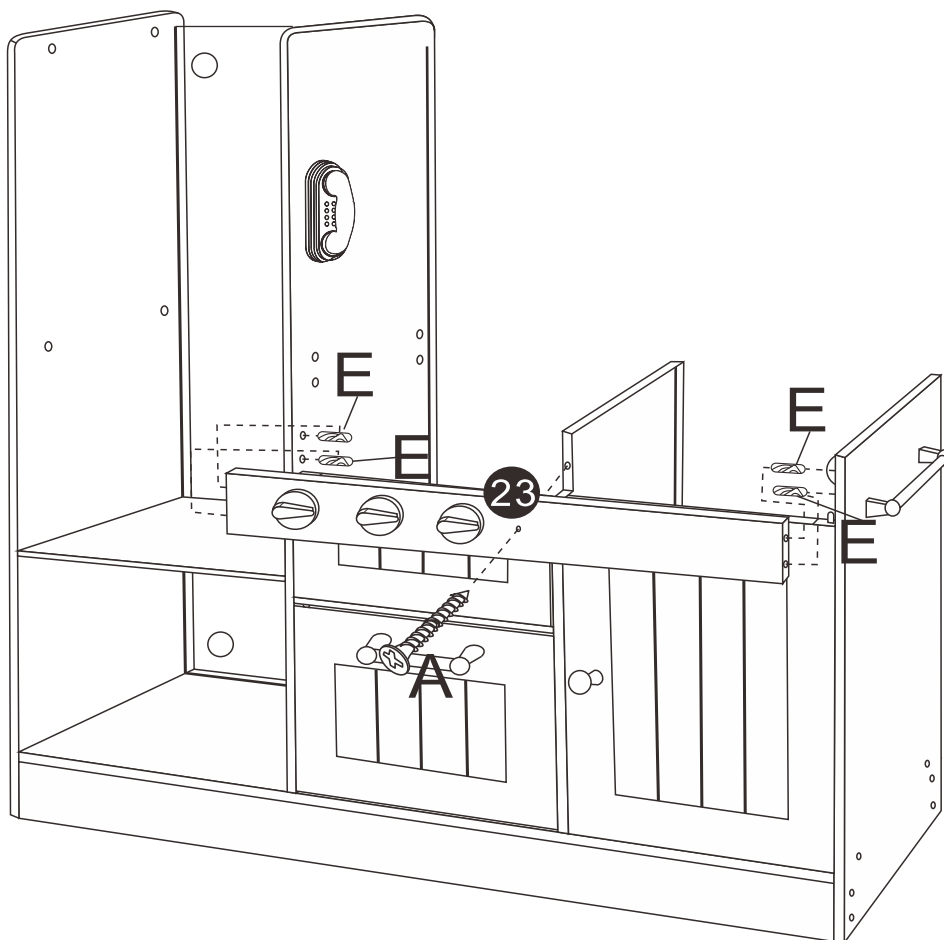

**Ax1  
Ex4**

**8**

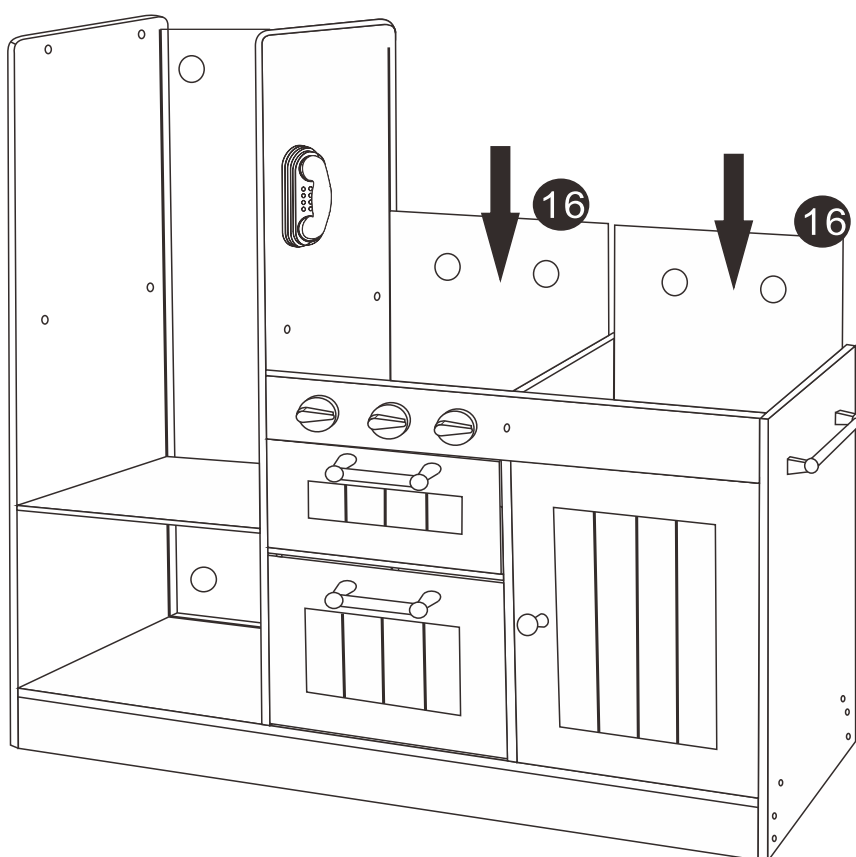

**IMPORTANT INFORMATION:**

- 1. Before installing, please refer to the manual to check each part.
- 2. If you experience any issue during the installation, please reach out to our service team for assistance: [tfsservices@163.com](mailto:tfsservices@163.com)

**9**

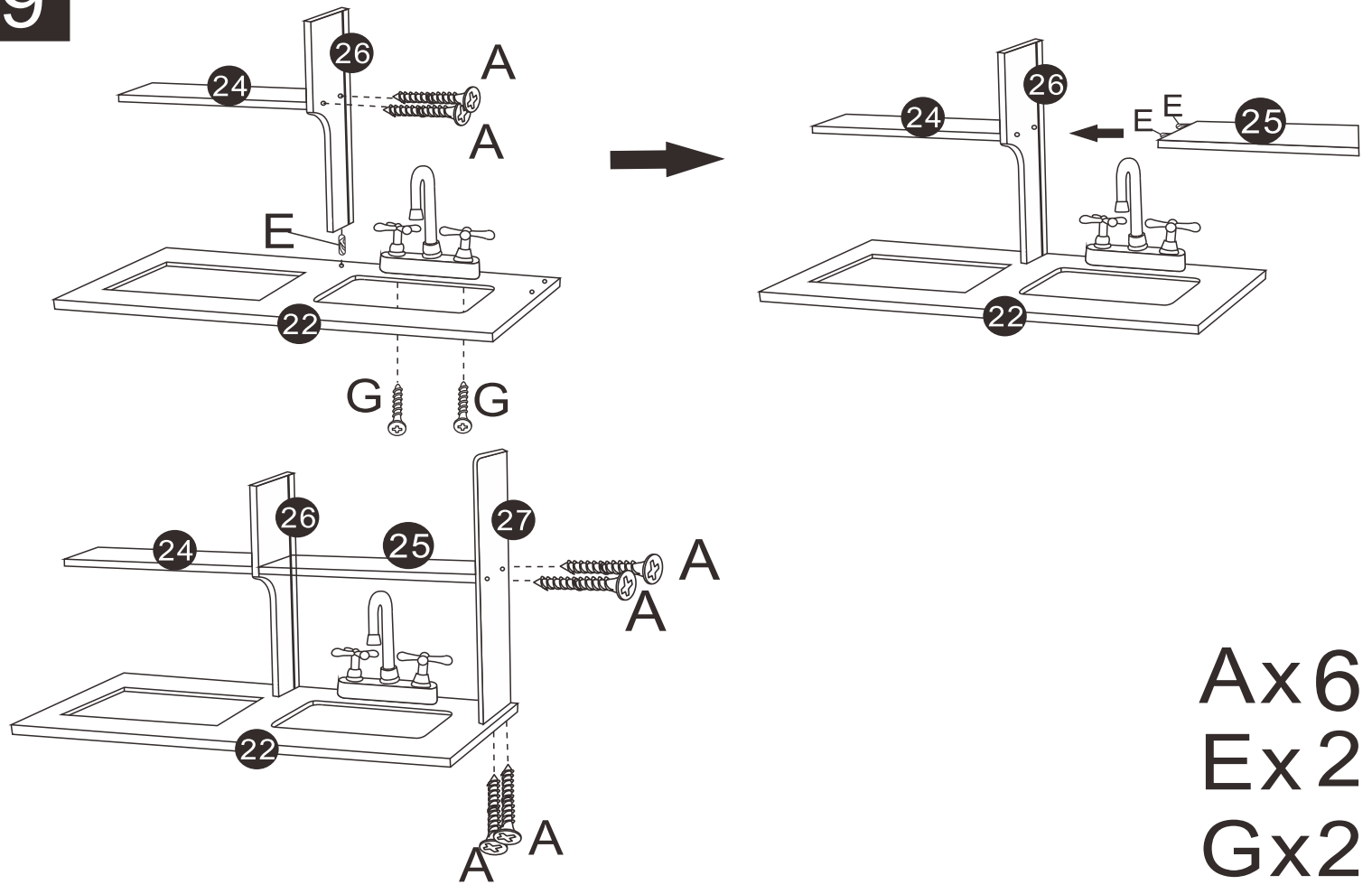

**10**

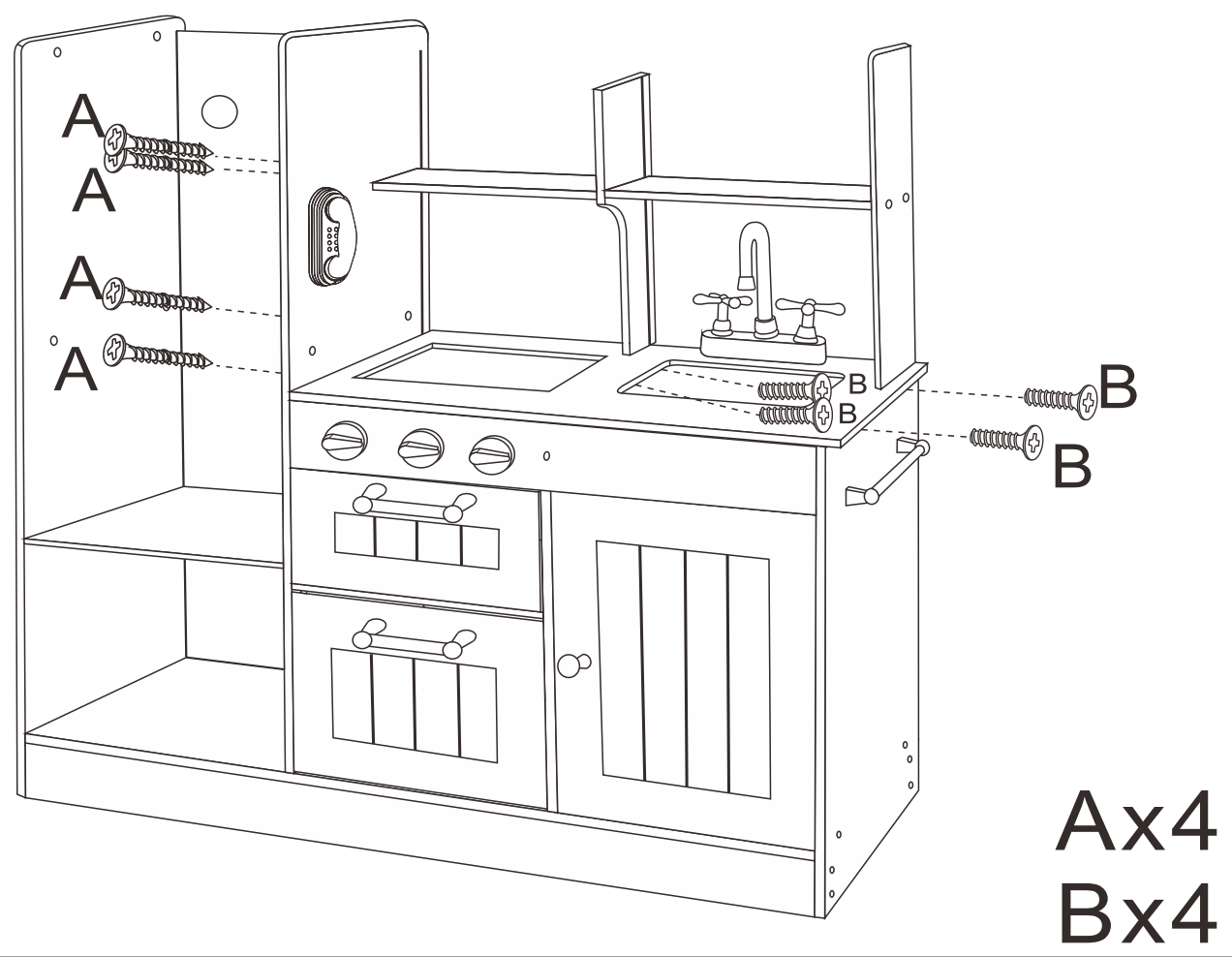

**IMPORTANT INFORMATION:**

1. Before installing, please refer to the manual to check each part.
2. If you experience any issue during the installation, please reach out to our service team for assistance: [tfservices@163.com](mailto:tfservices@163.com)

**11**

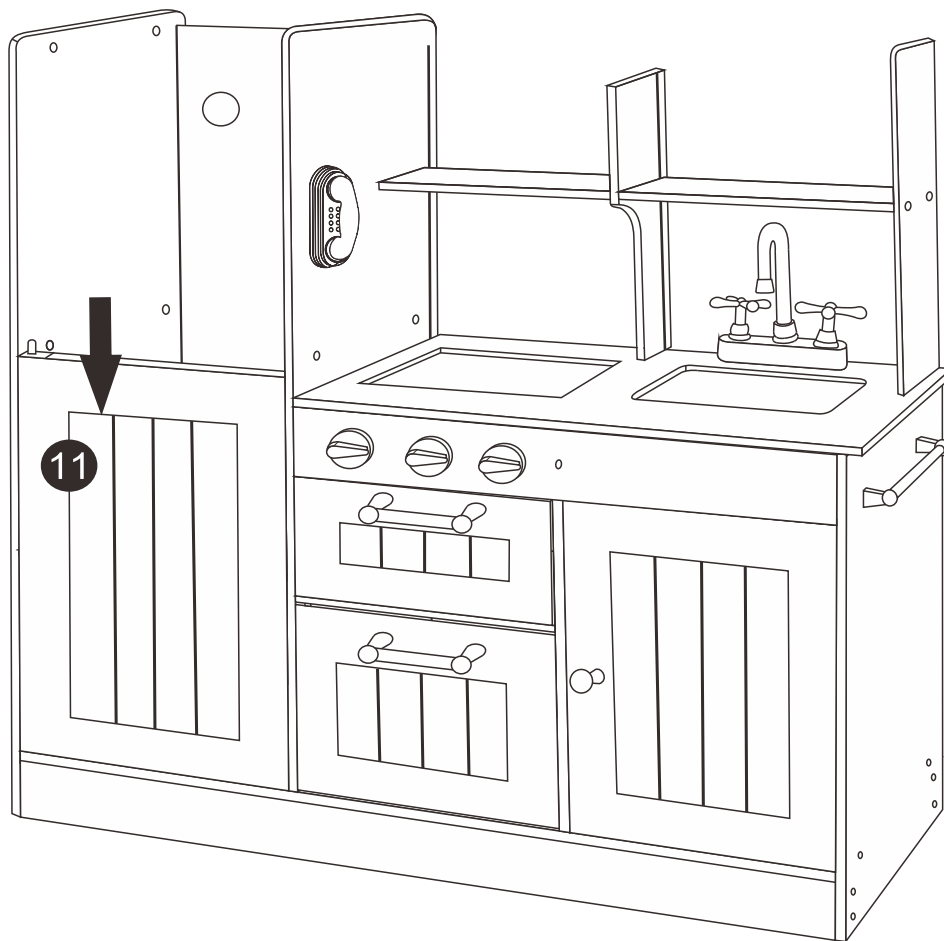

**12**

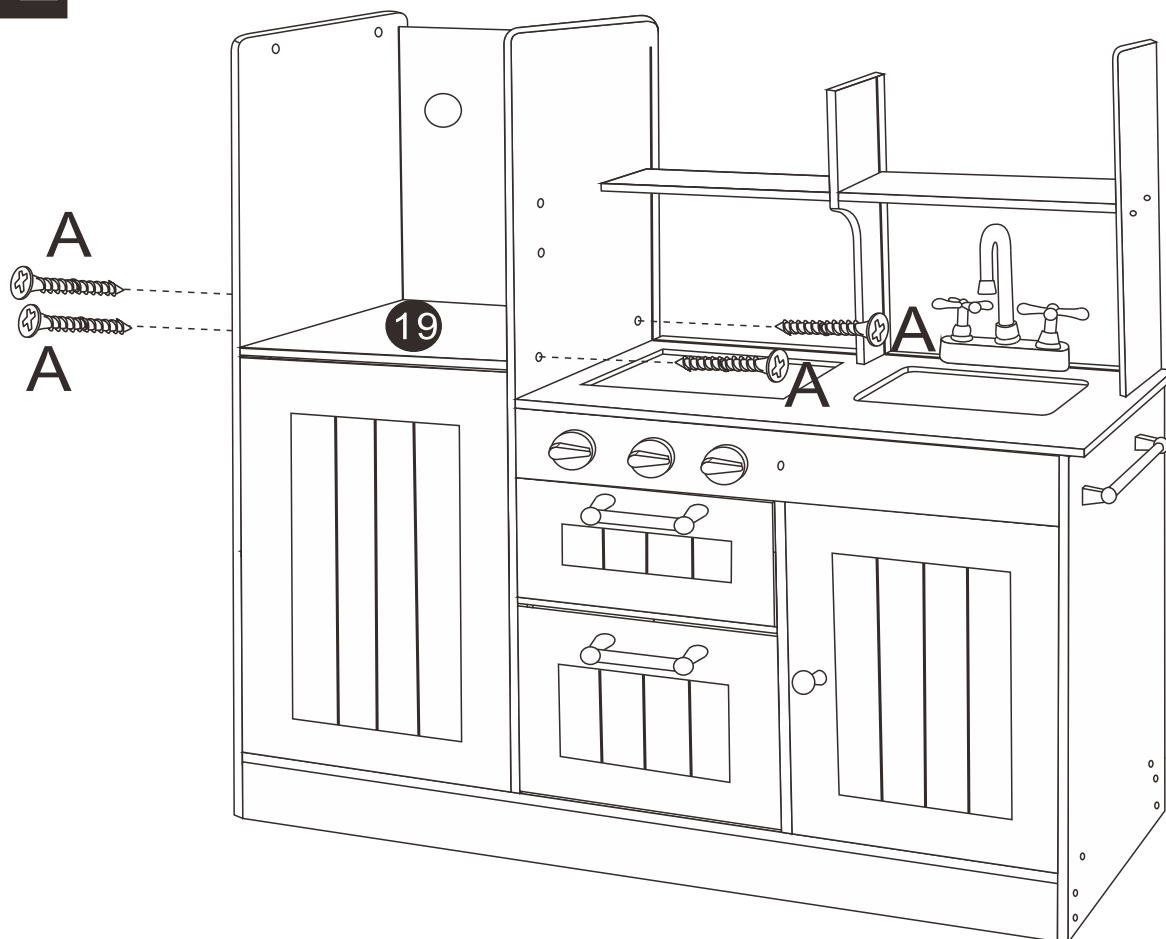

**A x 4**

**IMPORTANT INFORMATION:**

1. Before installing, please refer to the manual to check each part.
2. If you experience any issue during the installation, please reach out to our service team for assistance: [tfservices@163.com](mailto:tfservices@163.com)

**13**

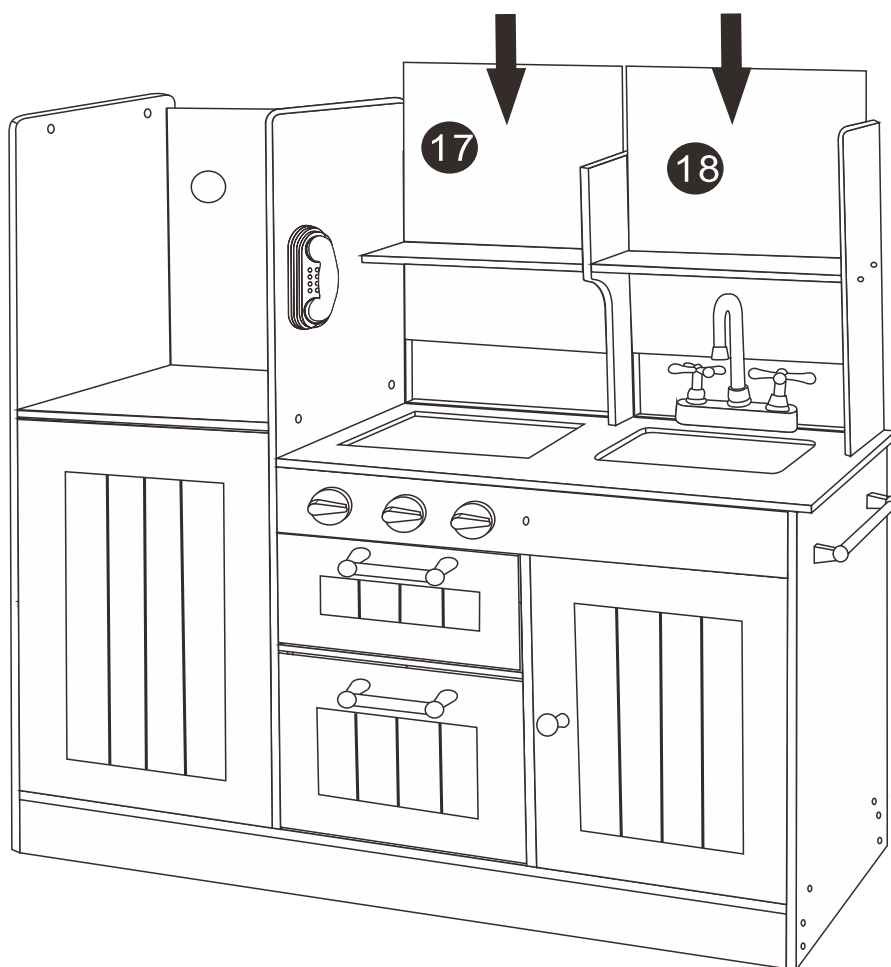

**14**

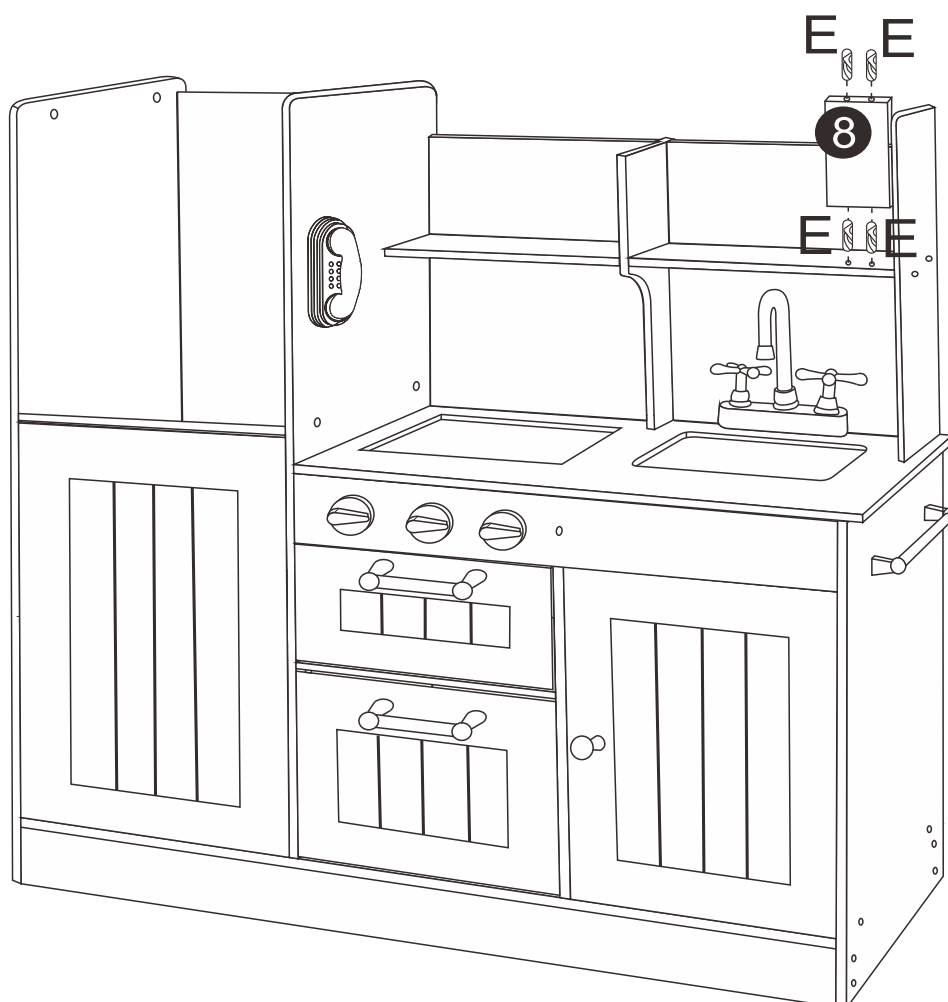

**Ex4**

**IMPORTANT INFORMATION:**

1. Before installing, please refer to the manual to check each part.
2. If you experience any issue during the installation, please reach out to our service team for assistance: [tfservices@163.com](mailto:tfservices@163.com)

**15**

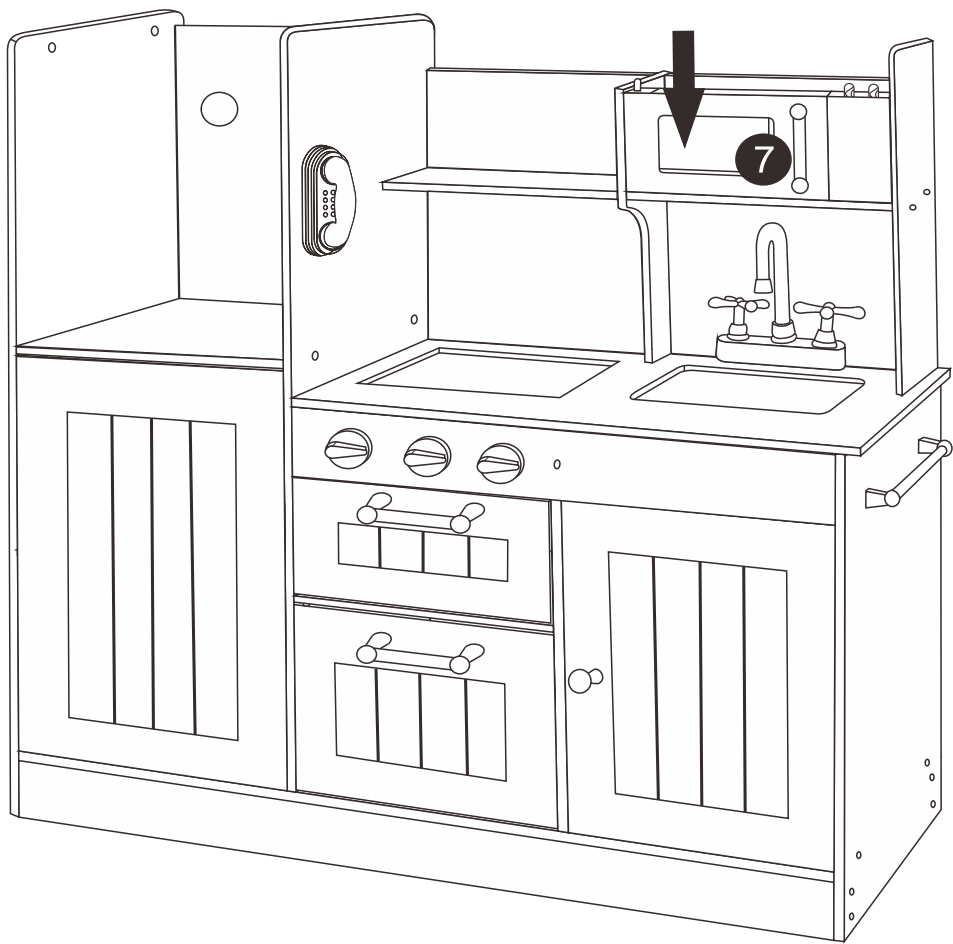

**16**

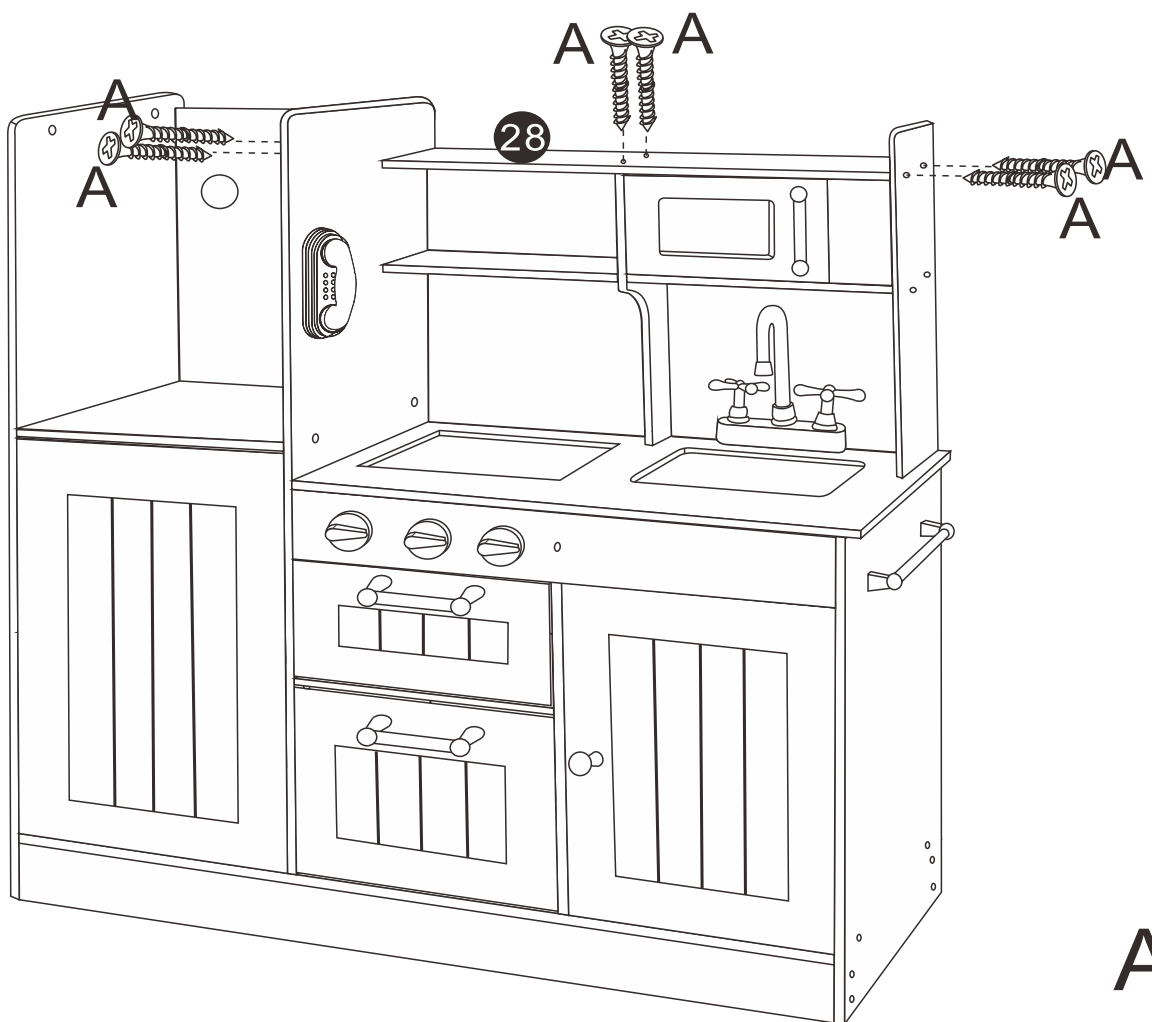

**Ax6**

**IMPORTANT INFORMATION:**

1. Before installing, please refer to the manual to check each part.
2. If you experience any issue during the installation, please reach out to our service team for assistance: [tfservices@163.com](mailto:tfservices@163.com)

**17**

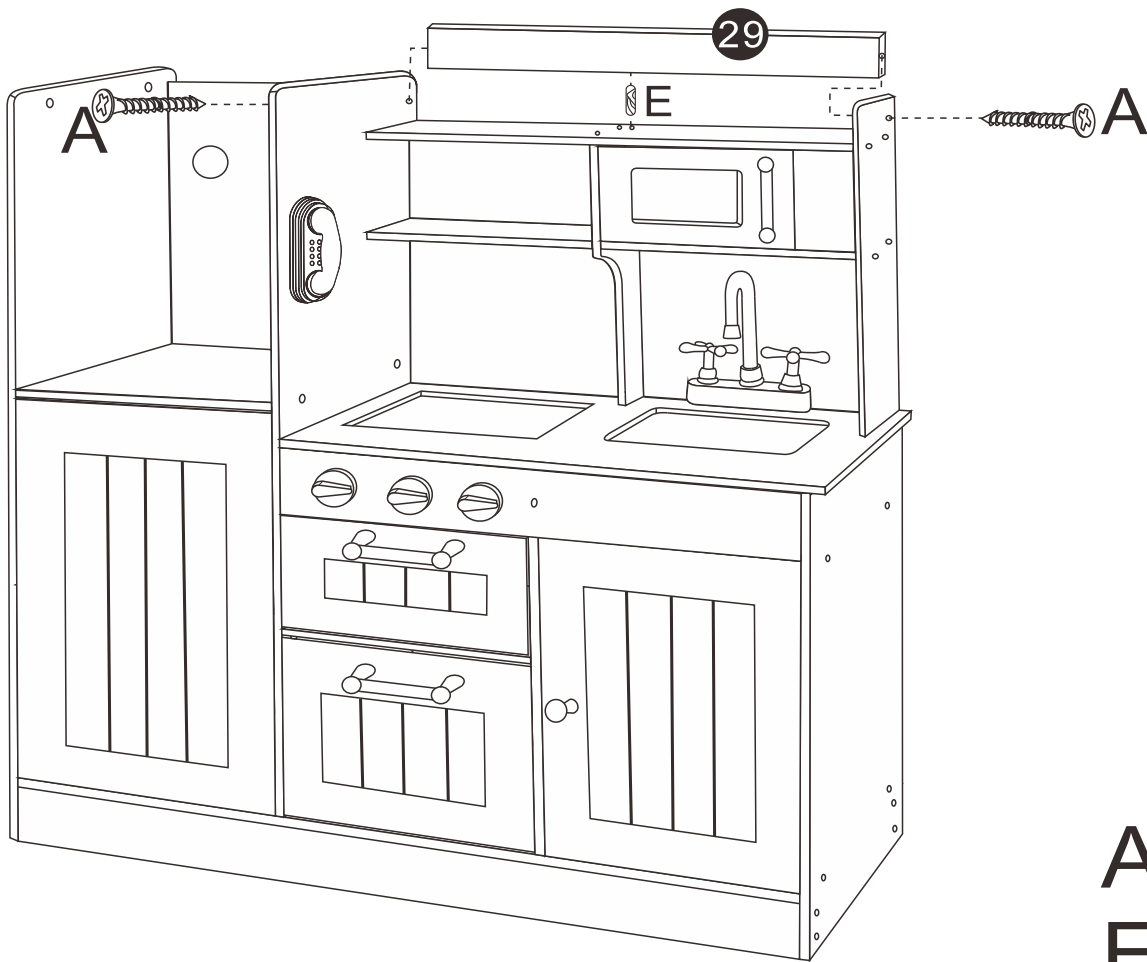

**Ax2**  
**Ex1**

**18**

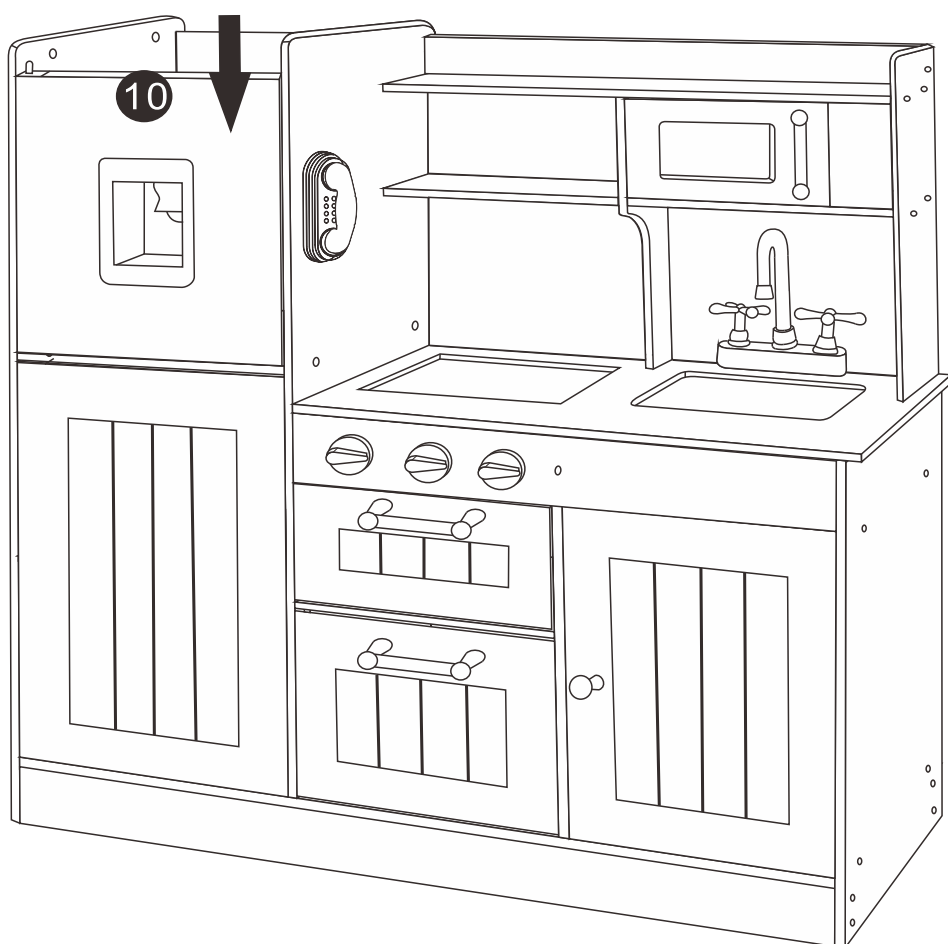

**IMPORTANT INFORMATION:**

1. Before installing, please refer to the manual to check each part.
2. If you experience any issue during the installation, please reach out to our service team for assistance: [tfsservices@163.com](mailto:tfsservices@163.com)

**19**

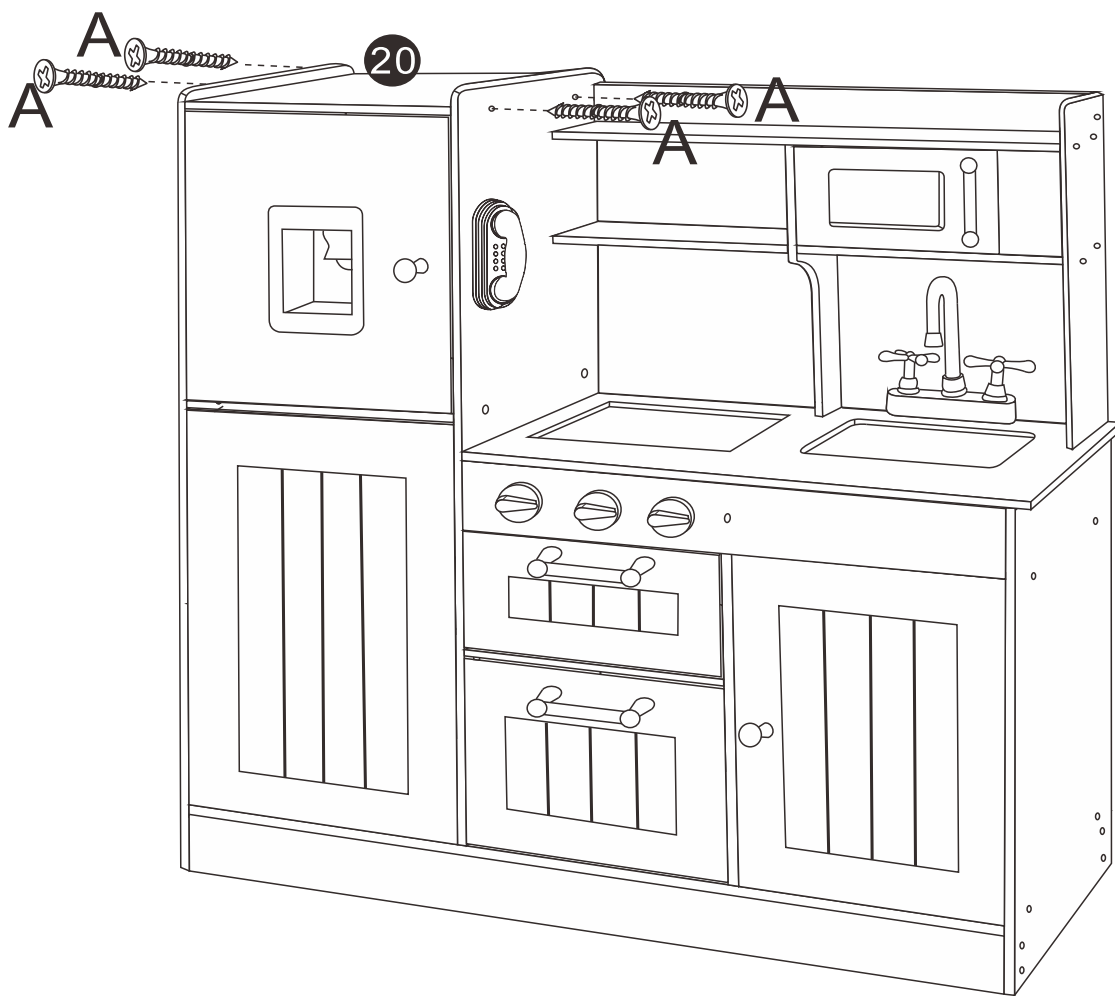

**A x 4**

**20**

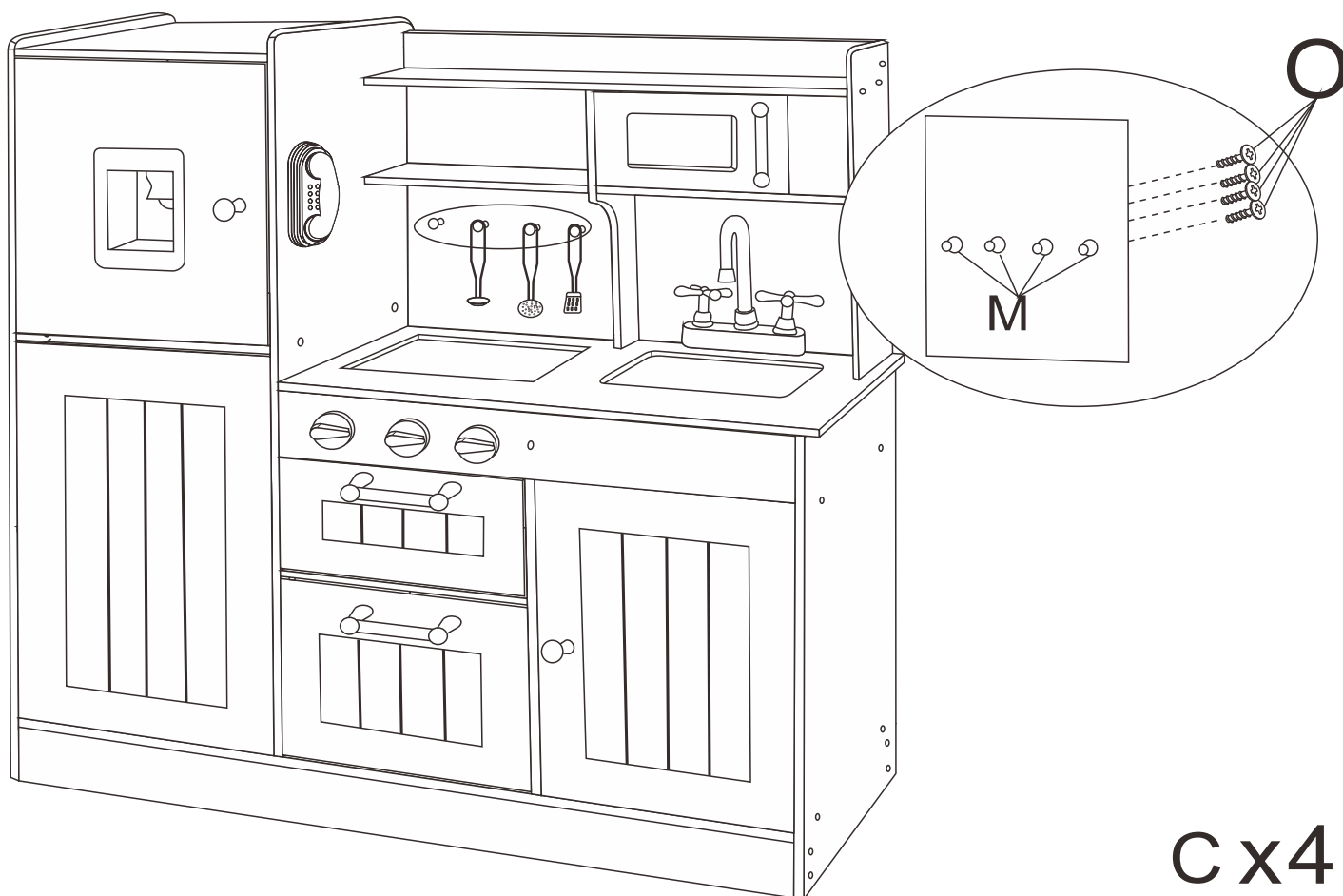

**C x 4**

**IMPORTANT INFORMATION:**

1. Before installing, please refer to the manual to check each part.
2. If you experience any issue during the installation, please reach out to our service team for assistance: [tfsservices@163.com](mailto:tfsservices@163.com)

**21**

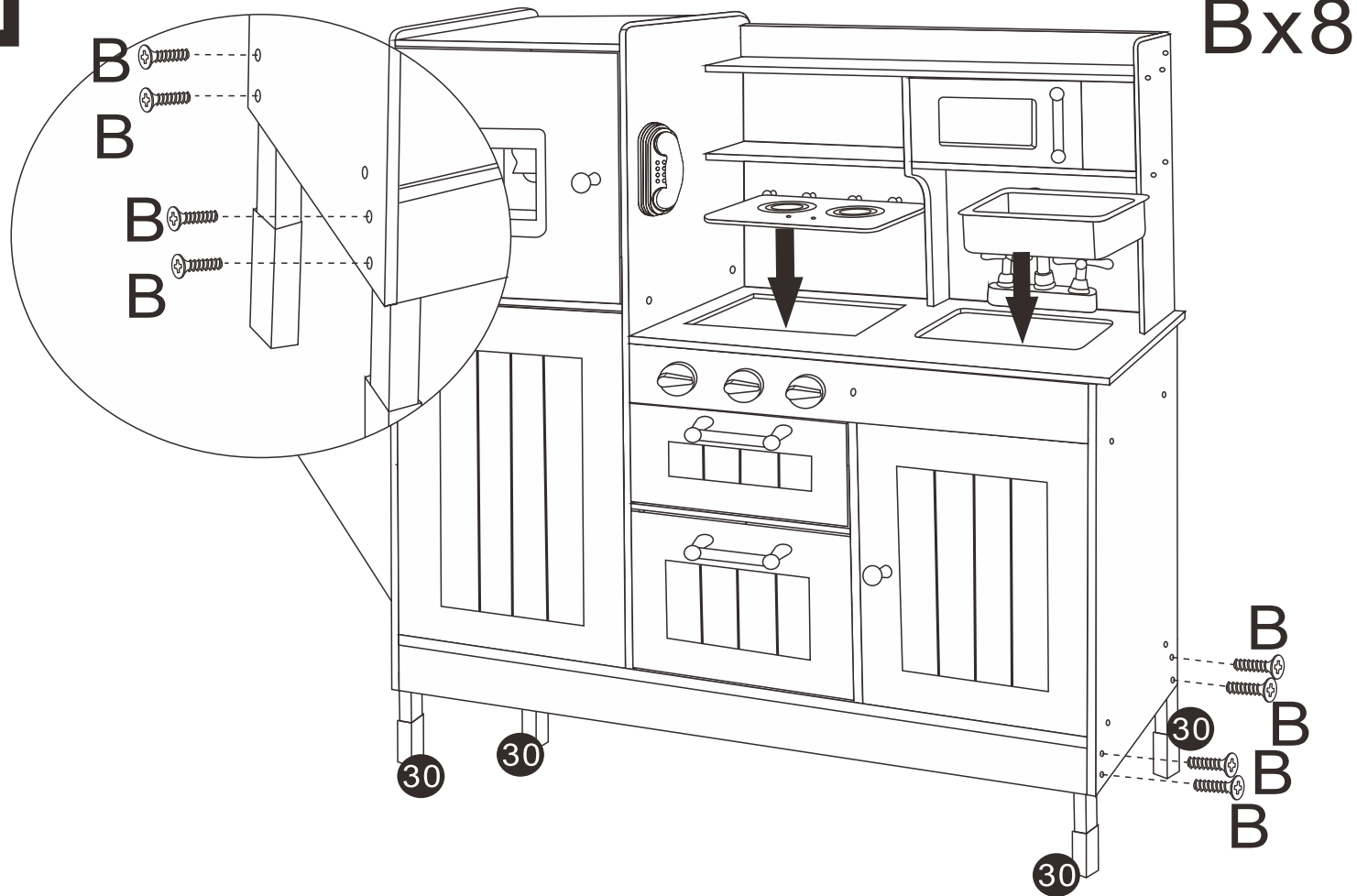

**22**

