

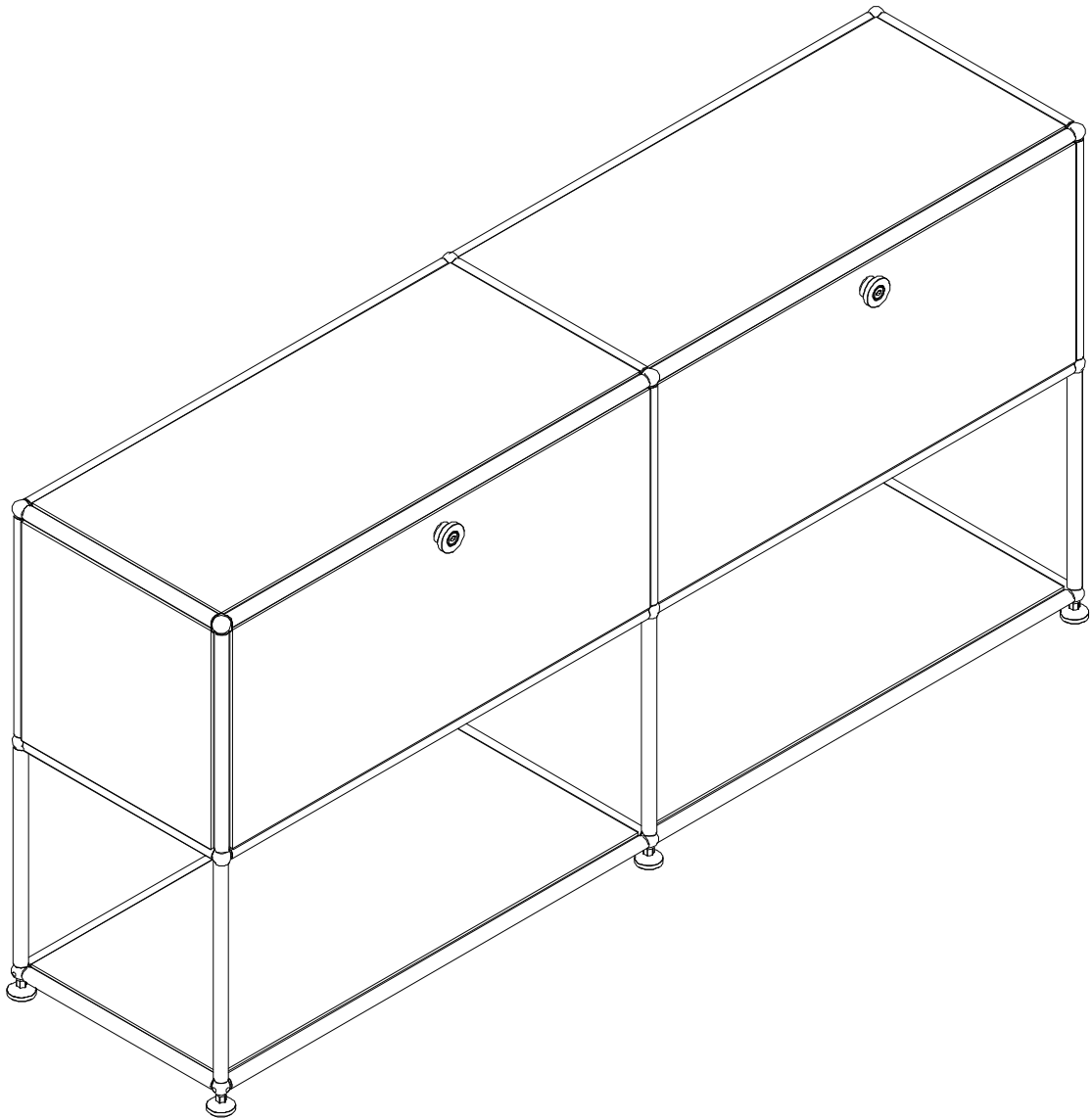



# ASSEMBLY INSTRUCTIONS



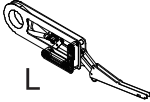
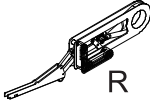
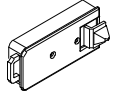
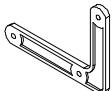
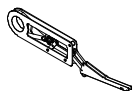

---

Storage Cabinets Type F



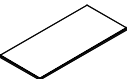

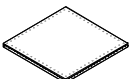
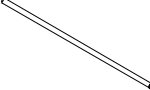
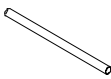
# Part List

①	②	③	④	⑤	⑥	⑦	⑧
							
x1	x2	x2	x1	x1	M3x28 x4	M4x25 x3	M4x14 x4

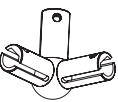
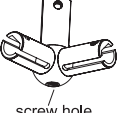
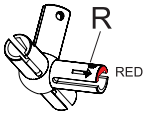
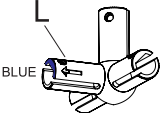
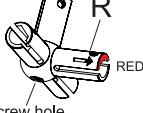
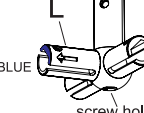
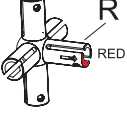
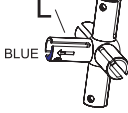
A	B	C	D	E1	E2	F	G
							
x8	x2	x2	x1	Long x12	Short x21	x2	x6

H1	H2	J1	J2	K1	K2	L1	L2
							
x4	x4	x3	x3	x1	x1	x1	x1

M	N	II
		
x66	x1	x1

**Step1**

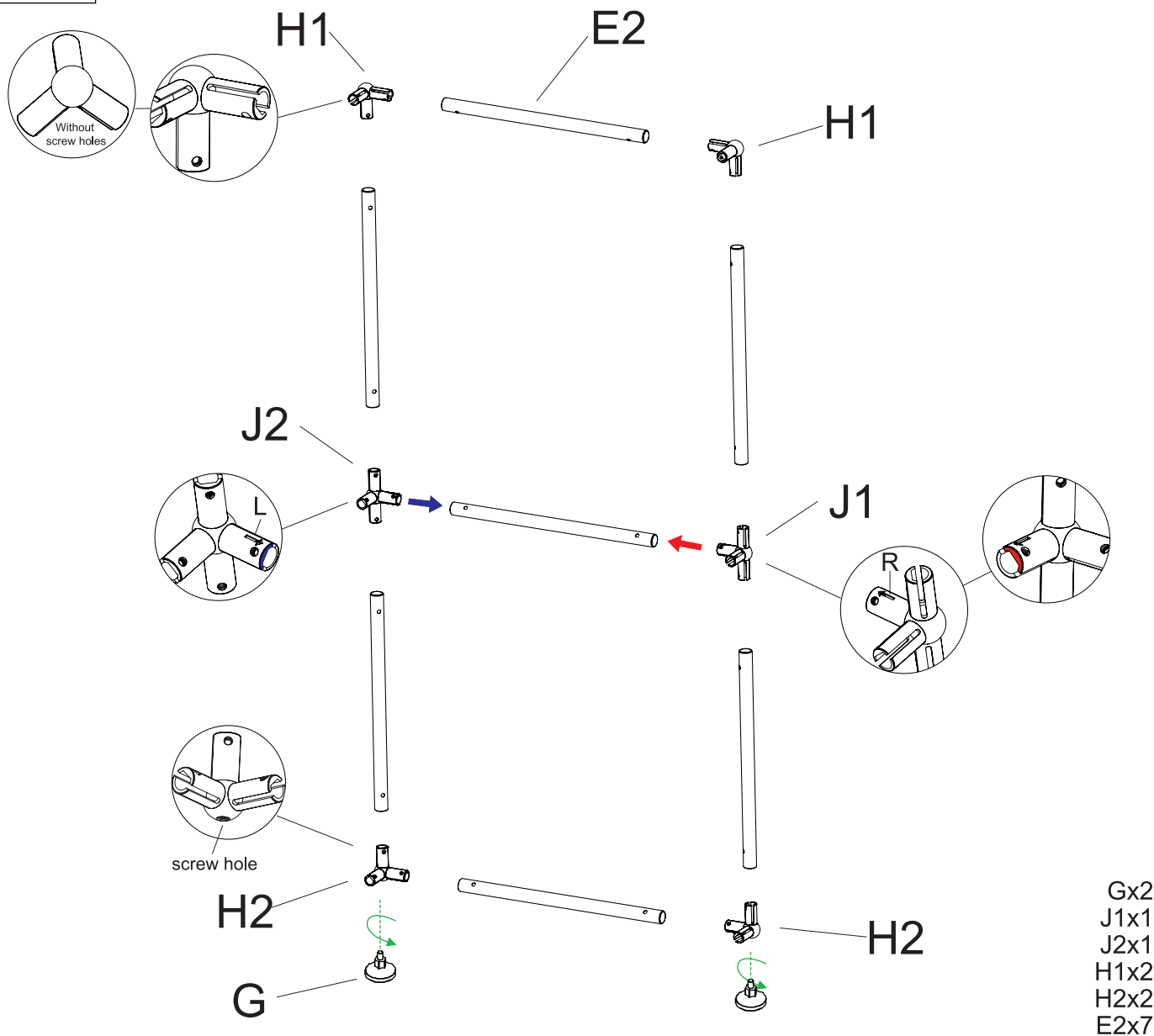

**Step2**

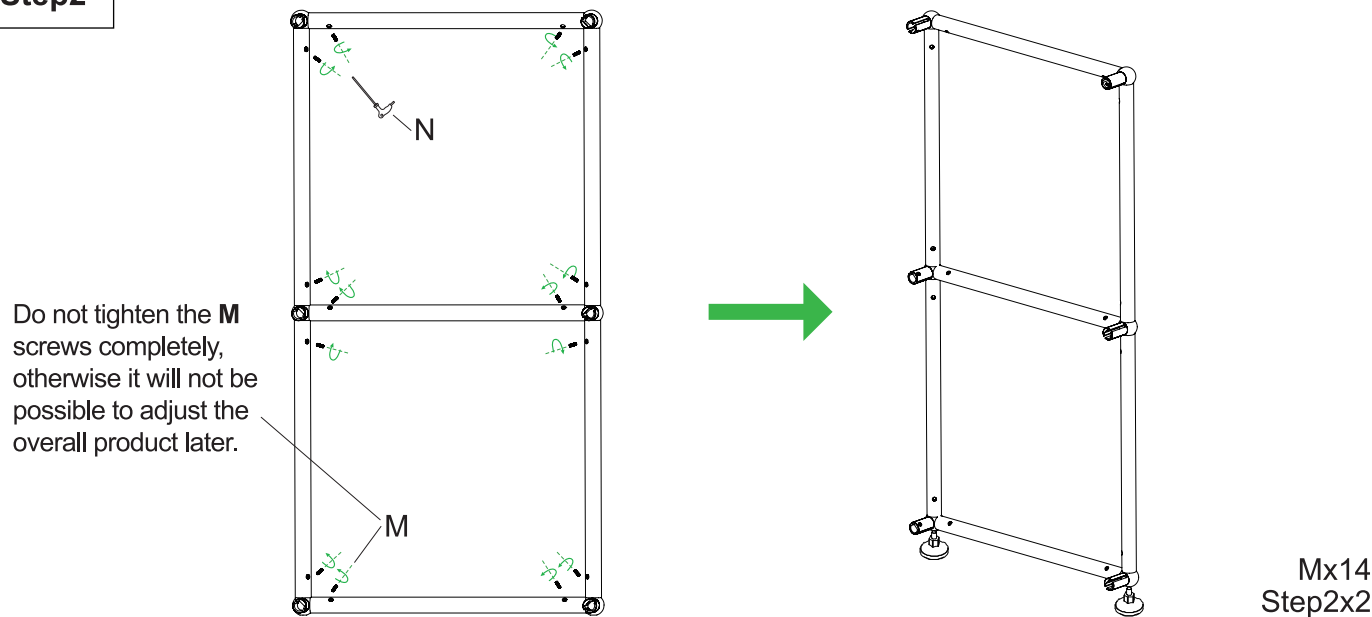

**Step3**

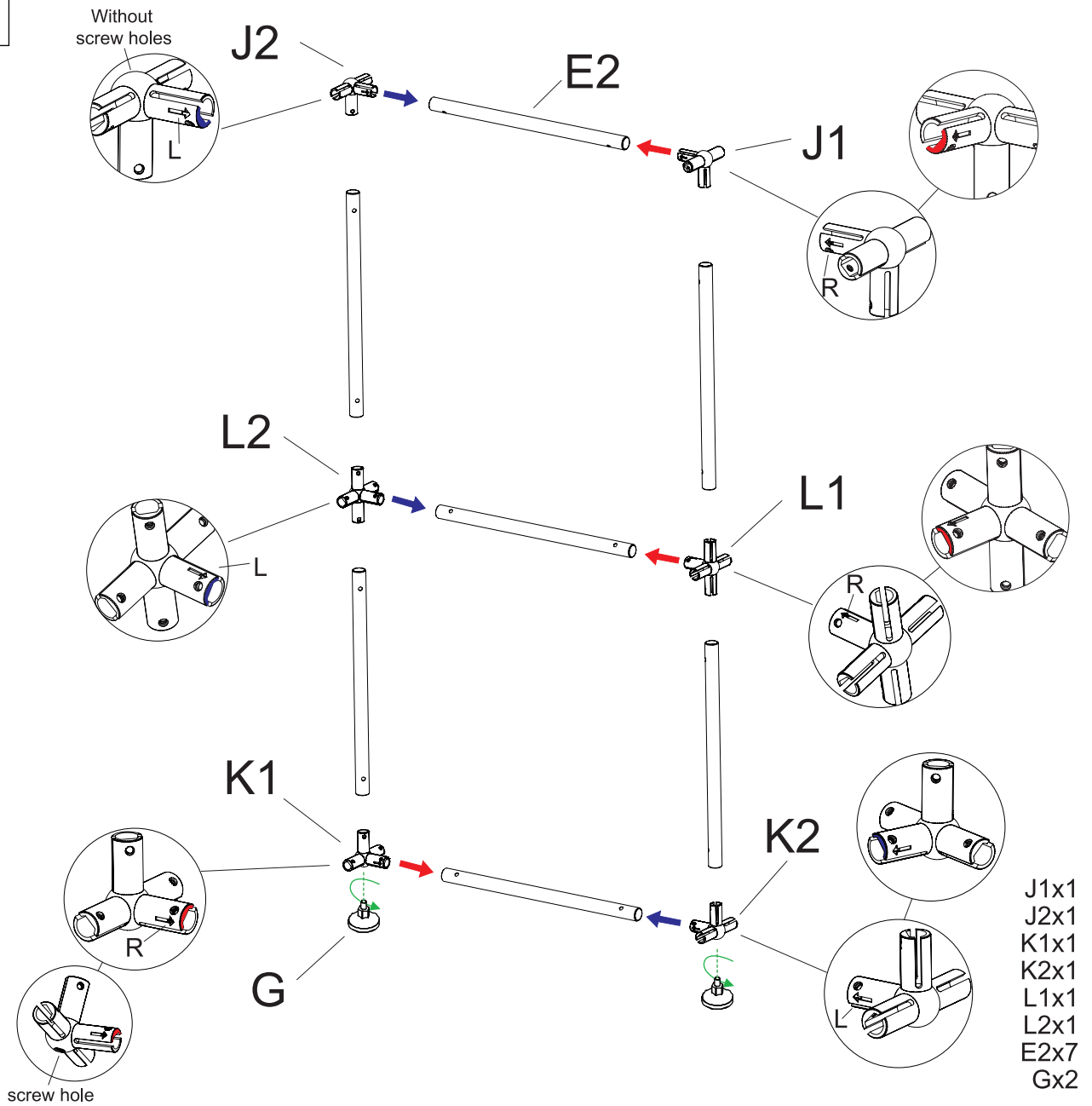

**Step4**

Do not tighten the **M** screws completely, otherwise it will not be possible to adjust the overall product later.

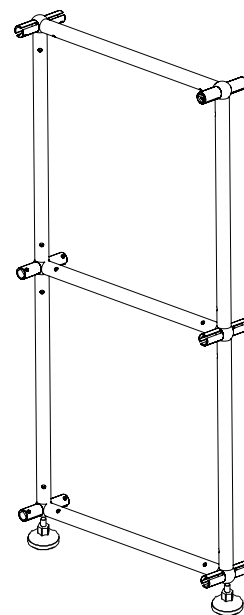
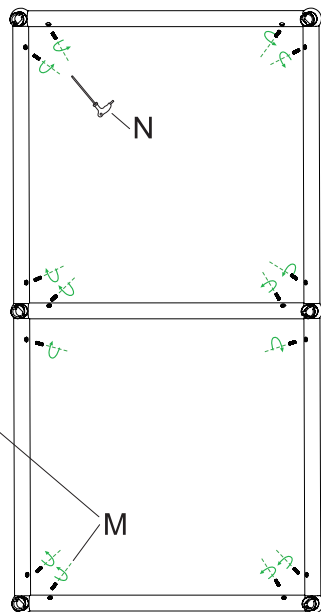

Mx14  
Step4x1

## Step5

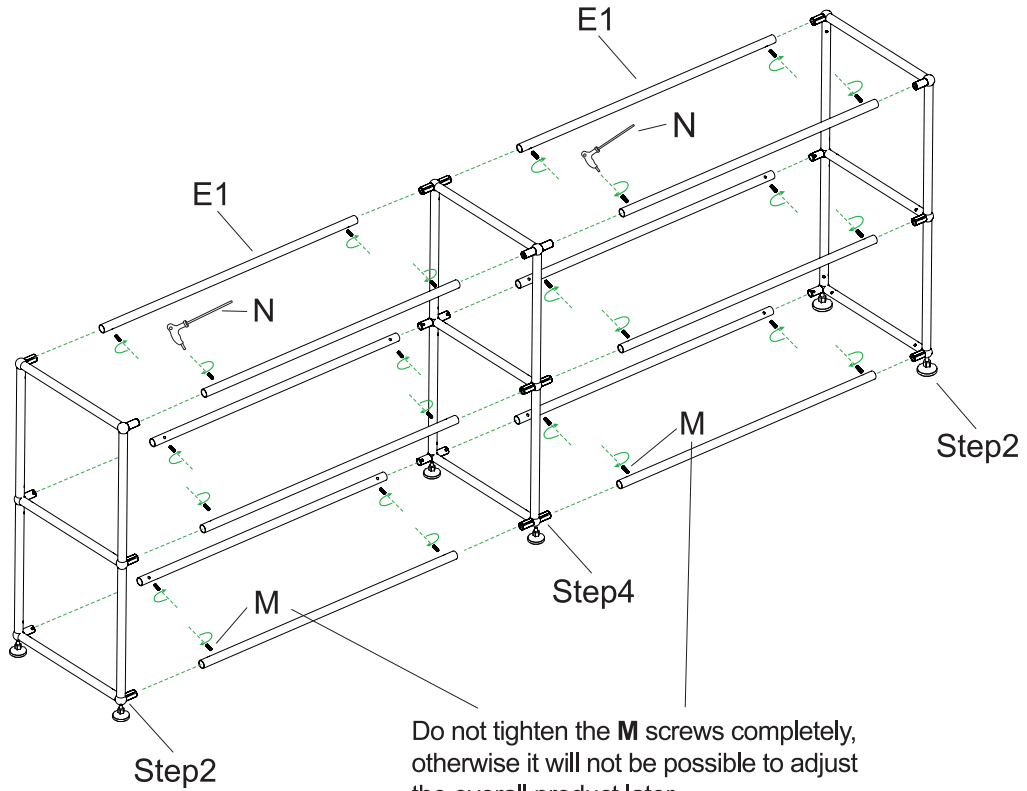

Mx24  
E1x12  
Step2x2  
Step4x1

## Step6

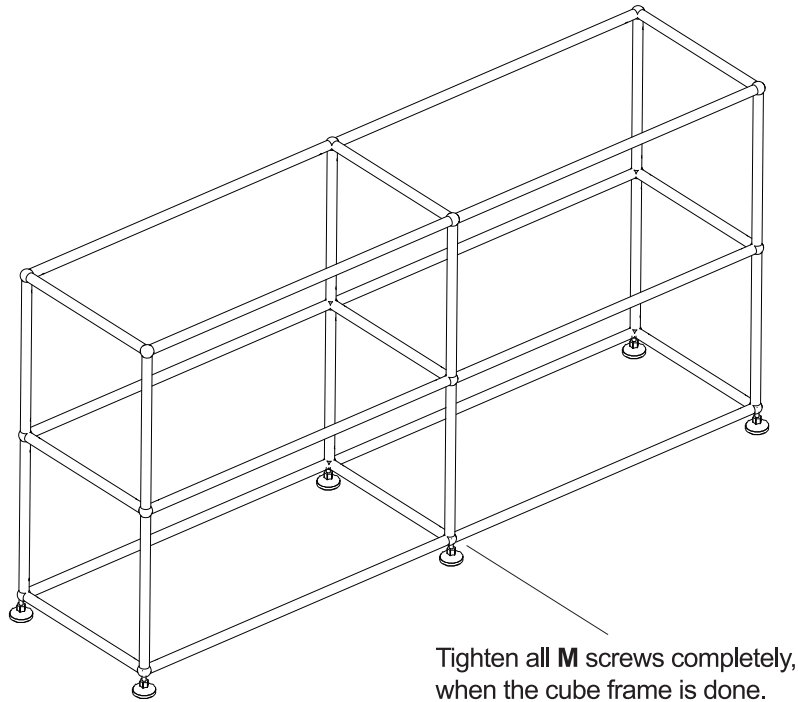

**Step7**

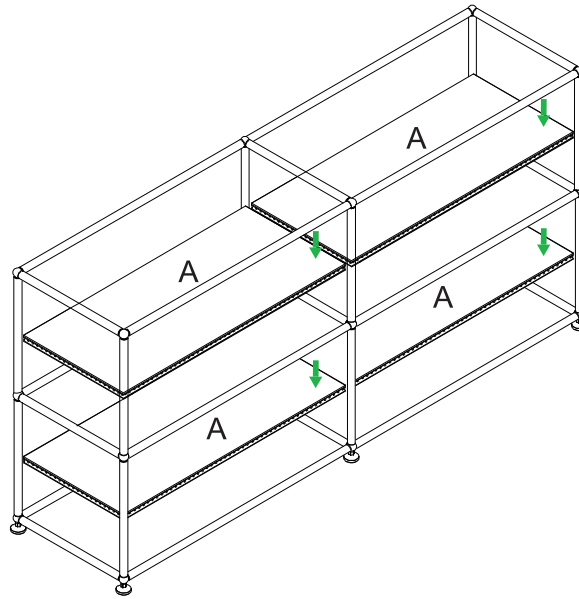

Ax4

**Step8**

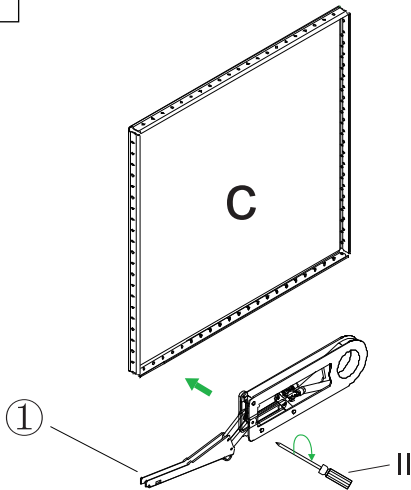

Partially unscrew the three screws in ① before installing it on the metal panel.

Cx1  
①x1  
Step8x1

**Step9**

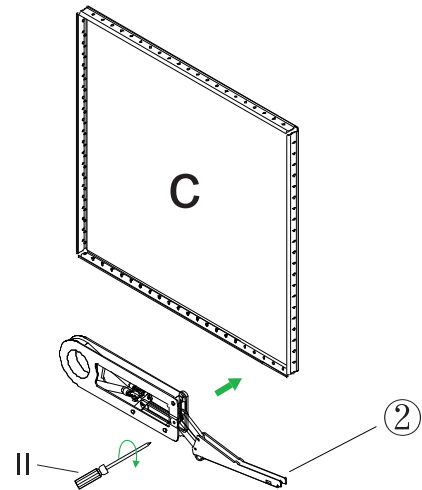

Partially unscrew the three screws in ② before installing it on the metal panel.

Cx1  
②x1  
Step9x1

**Step10**

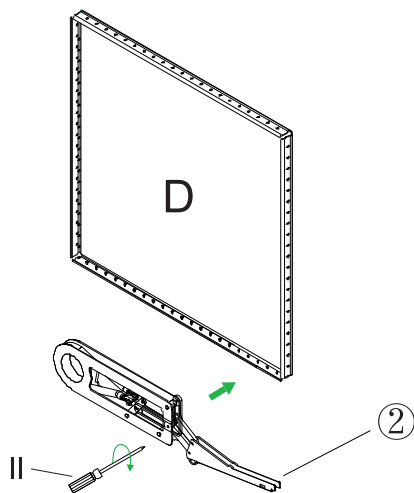

Partially unscrew the three screws in ② before installing it on the metal panel.

Dx1  
②x1  
Step10x1

**Step11**

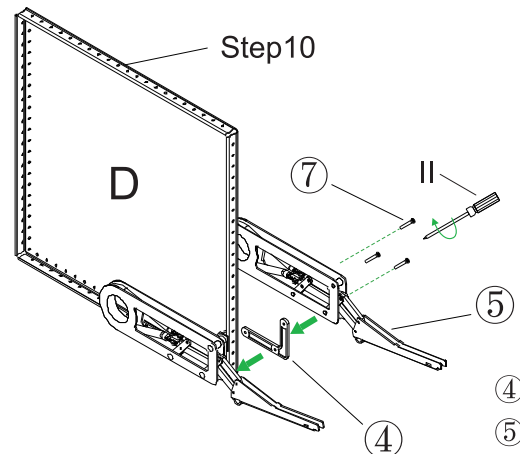

④x1  
⑤x1  
⑦x3  
Step10x1  
Step11x1

Step12

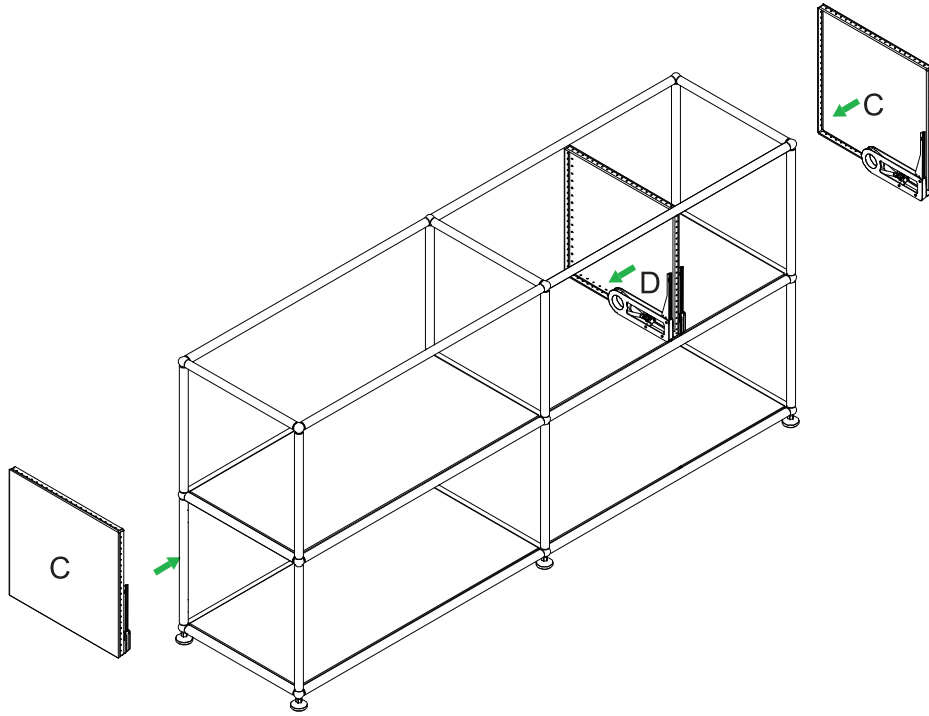

Step8x1  
Step9x1  
Step11x1

Step13

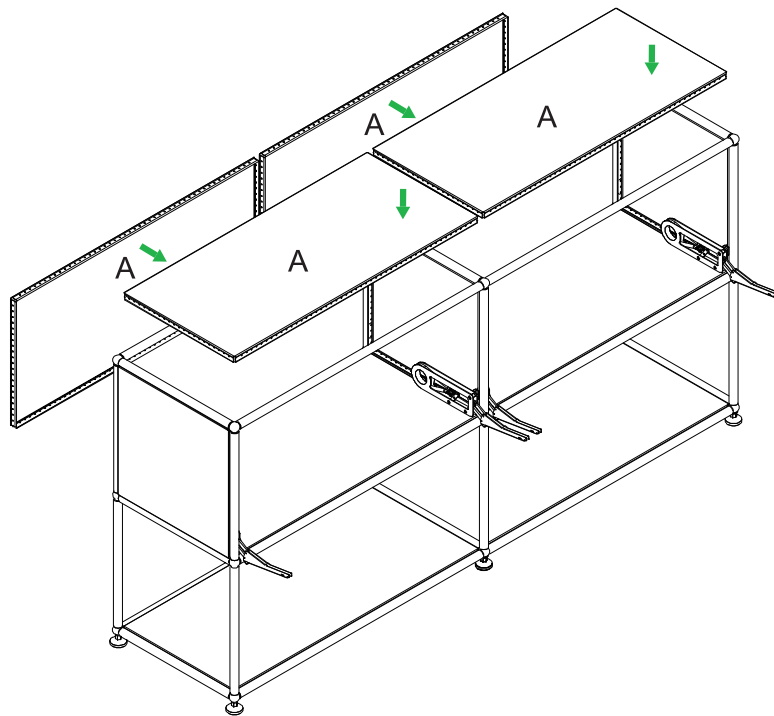

Ax4

### Step14

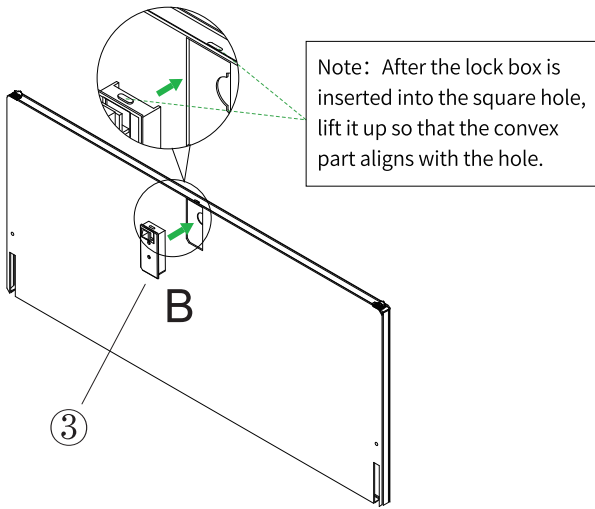

③x1  
Bx1

### Step15

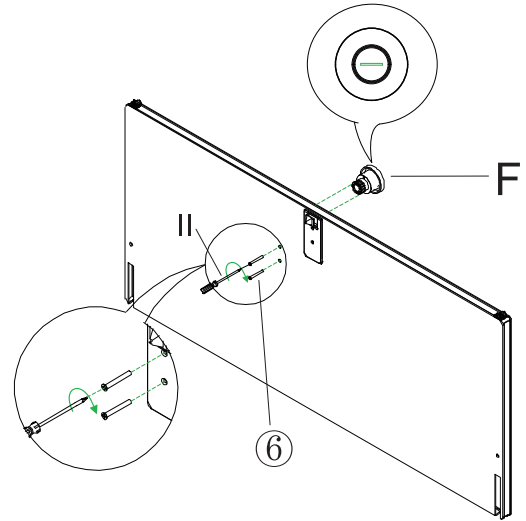

⑥x2  
Fx1  
Step15x2

### Step16

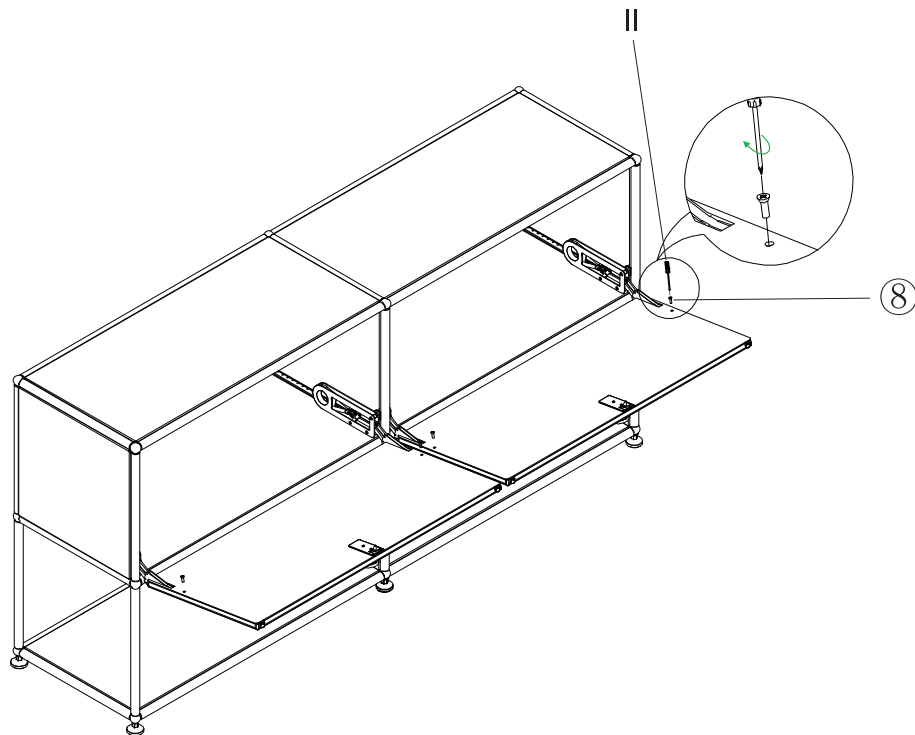

⑧x4

**Finish**

