

Electric Fireplace With Mantel Assembly Instructions

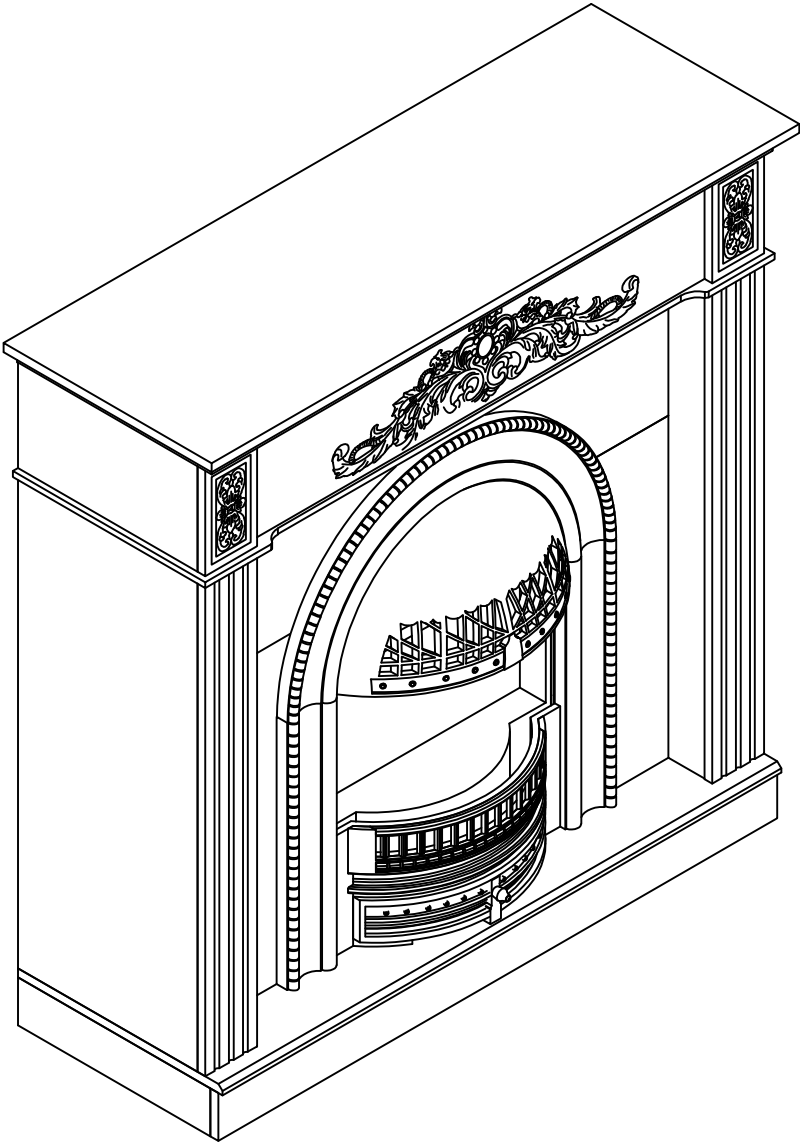

PACKAGE INCLUDE

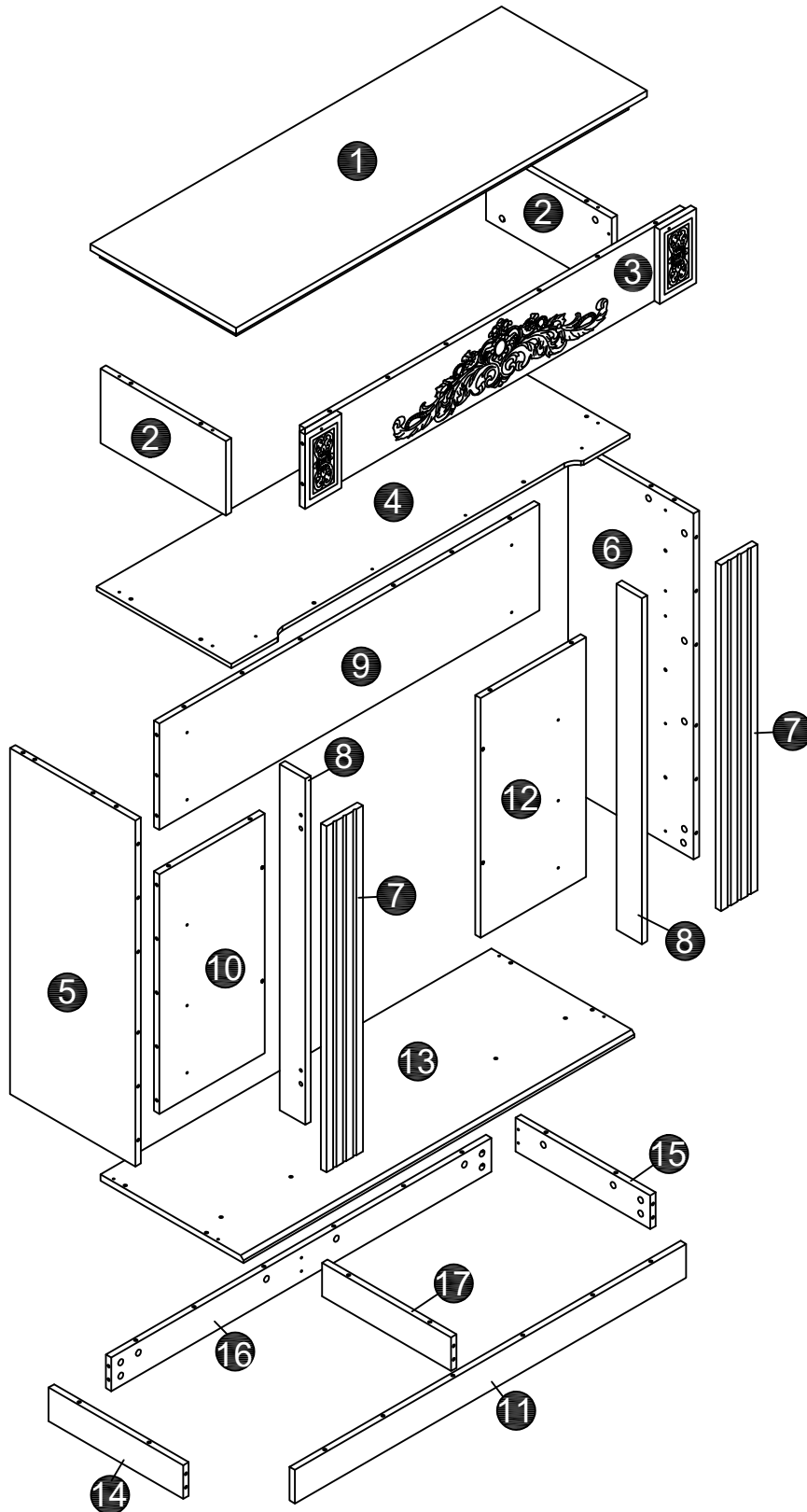







STRUCTURE FOR REFERENCE TO ASSEMBLY

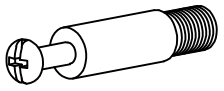

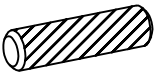
PART IDENTIFICATION

CODE	DESCRIPTION	QTY
1	Top panel	1
2	Upper side panels	2
3	Upper front plate	1
4	Upper slab	1
5	Lower left side panel	1
6	Lower right side panel	1
7	Lower side posts	2
8	Lower middle side panels	2
9	Horizontal furnace core plate	1
10	Left shaft core plate	1
11	Front foot strips	1
12	Right vertical furnace core plate	1
13	motherboard	1
14	Left foot bar	1
15	Right foot bar	1
16	Hind foot strips	1
17	Midsole Strip	1

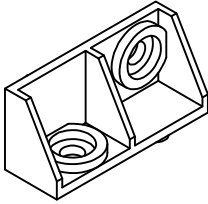
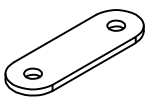
PACKAGE CONTENT

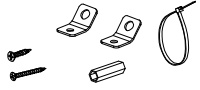
 <p>A 76+2</p>	<p>Ø15x12MM</p>  <p>B 76+2</p>	<p>Ø8x30MM</p>  <p>C 44+1</p>	<p>M6x30MM</p>  <p>D 5x+1</p>
<p>Ø5x38MM</p>  <p>E 10+1</p>	<p>M6x12MM</p>  <p>F 8+1</p>	 <p>G 4x</p>	 4x  8x <p>H</p>
 <p>I 2x</p>			

How to use the cam lock system

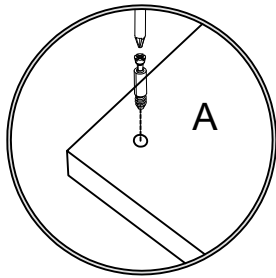

1. Screw cam bolt into panel

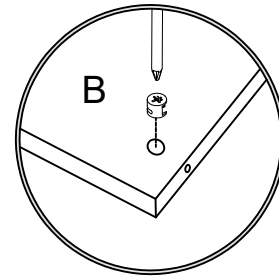

2. Push cam into panel - arrow feature on cam top points to panel edge

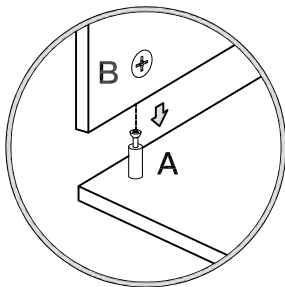

3. align cam bolt(s) with cam(s) and insert all the way into cross-bored hole(s)

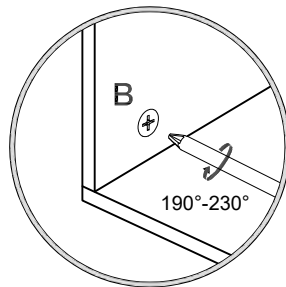

4. Rotate cam(s) clockwise 190°-230° to lock panels together

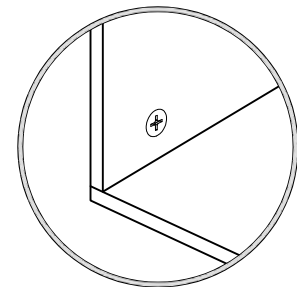

5. Panels should be tight against each other and connection should be rigid

Insert the wood dowel [C] at least half way by tapping lightly with a rubber mallet, IF NECESSARY.

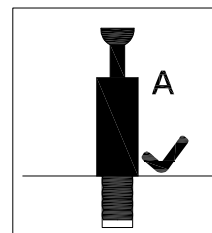
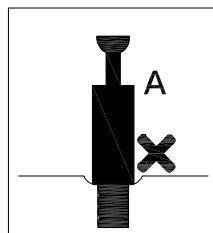
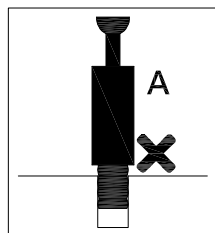
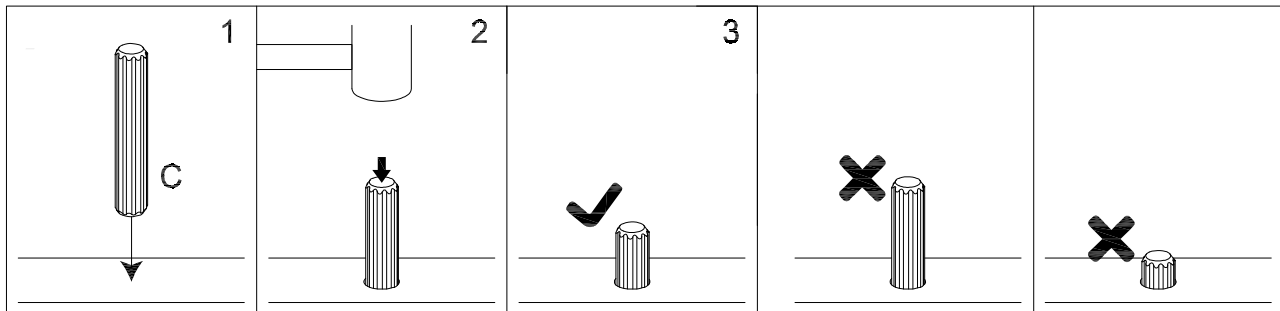

⚠ WARNING

- Unit must be placed on a level surface or leveled with included hardware (when applicable).
- Do not sit or stand on or allow children to climb, sit or stand on the assembled product.
- For safety reasons, it is imperative that this unit be mounted to the wall.
- Do not use without installing the tip restraint.
- Unit can tip over causing severe injury or death.
- Do not exceed the recommended weight limits.
- Evenly distribute the weight on each level and always keep the heavier loads on the bottom.
- Before cutting, drilling or hammering into any wall or floor surface, verify the location of electrical, plumbing and gas lines. Cutting may cause serious injury.

You are now ready to assemble the Electric Fireplace with mantel

Before installing:

1. Read through all instructions first
2. Check all shelf parts and their layout
3. Compare your assembled bookshelf with the finished diagram to confirm everything's correct

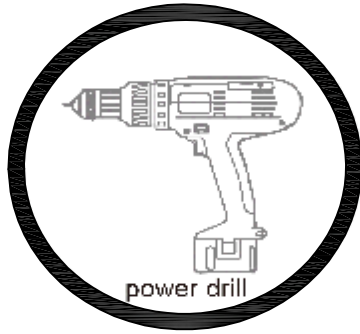

We recommend using a power drill to assemble.

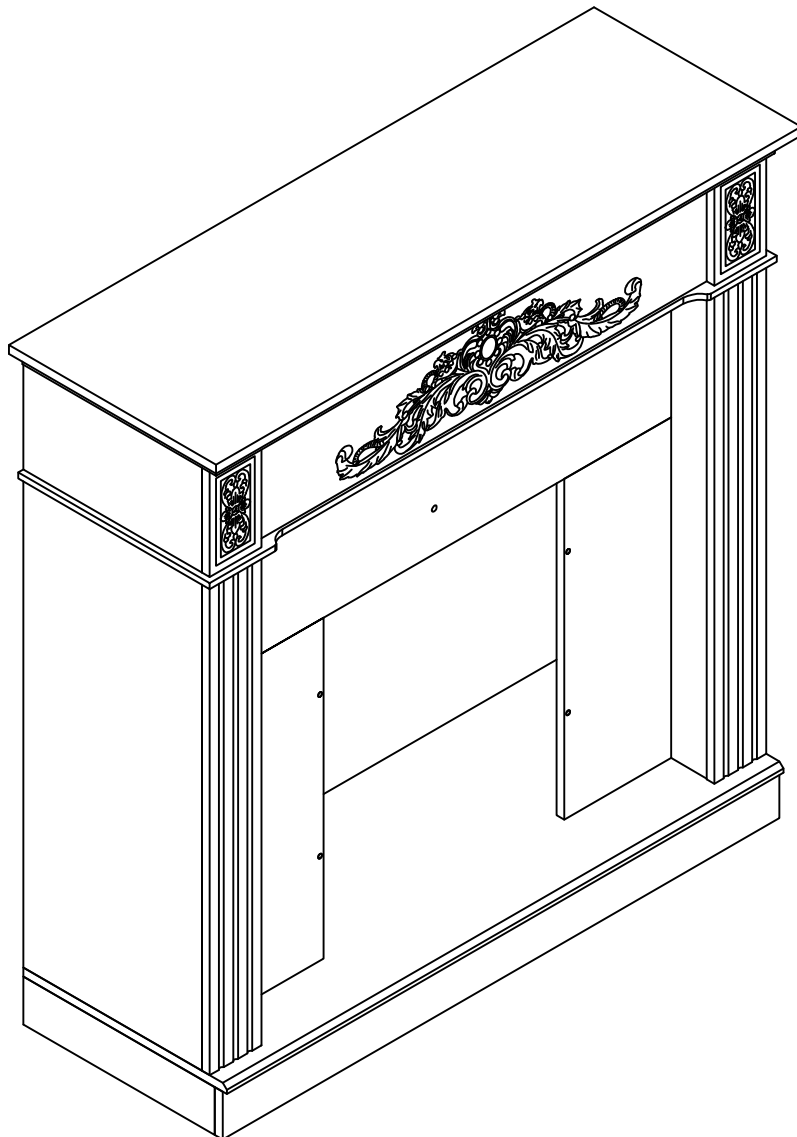

STEP 1

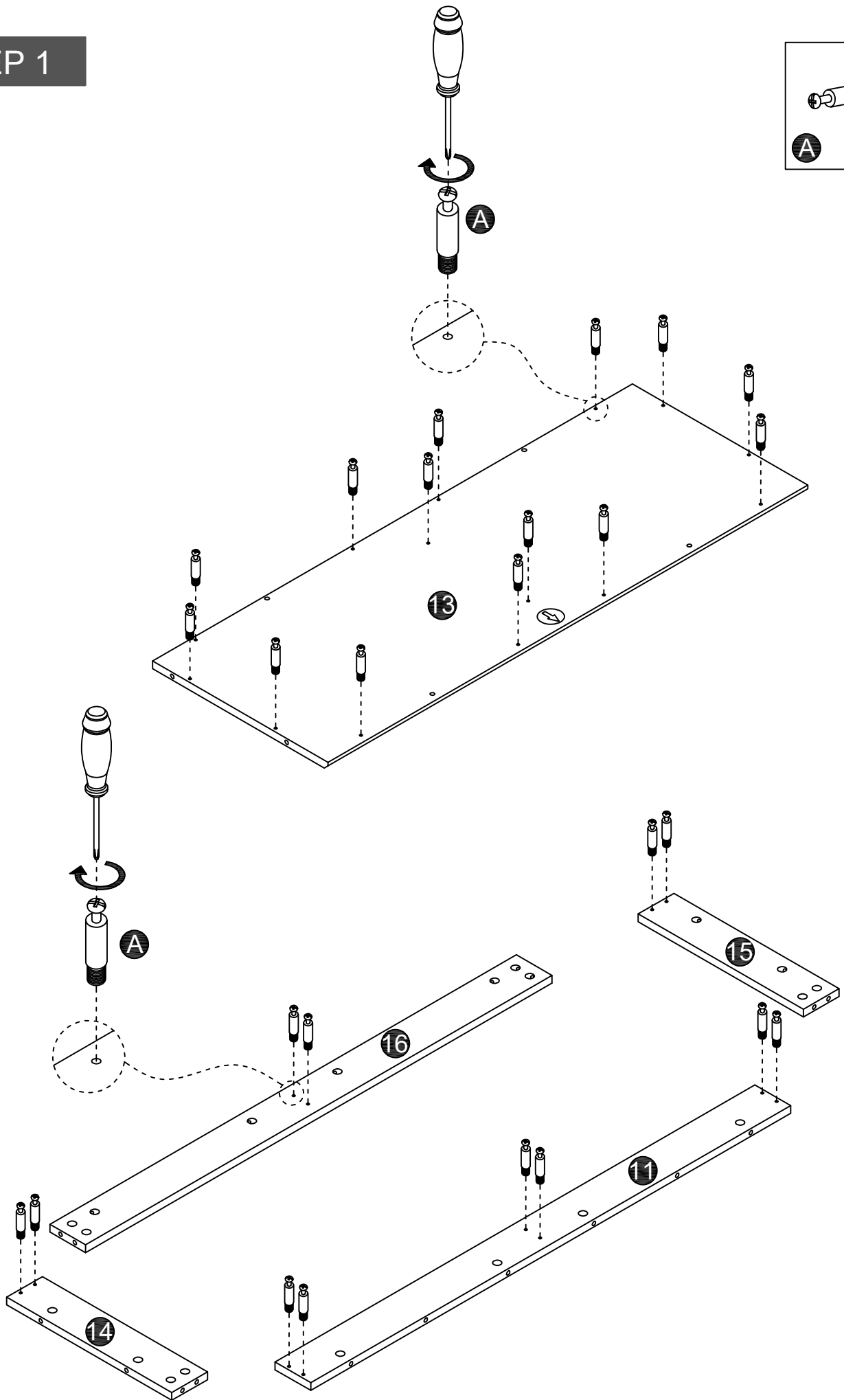
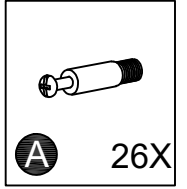

STEP 2

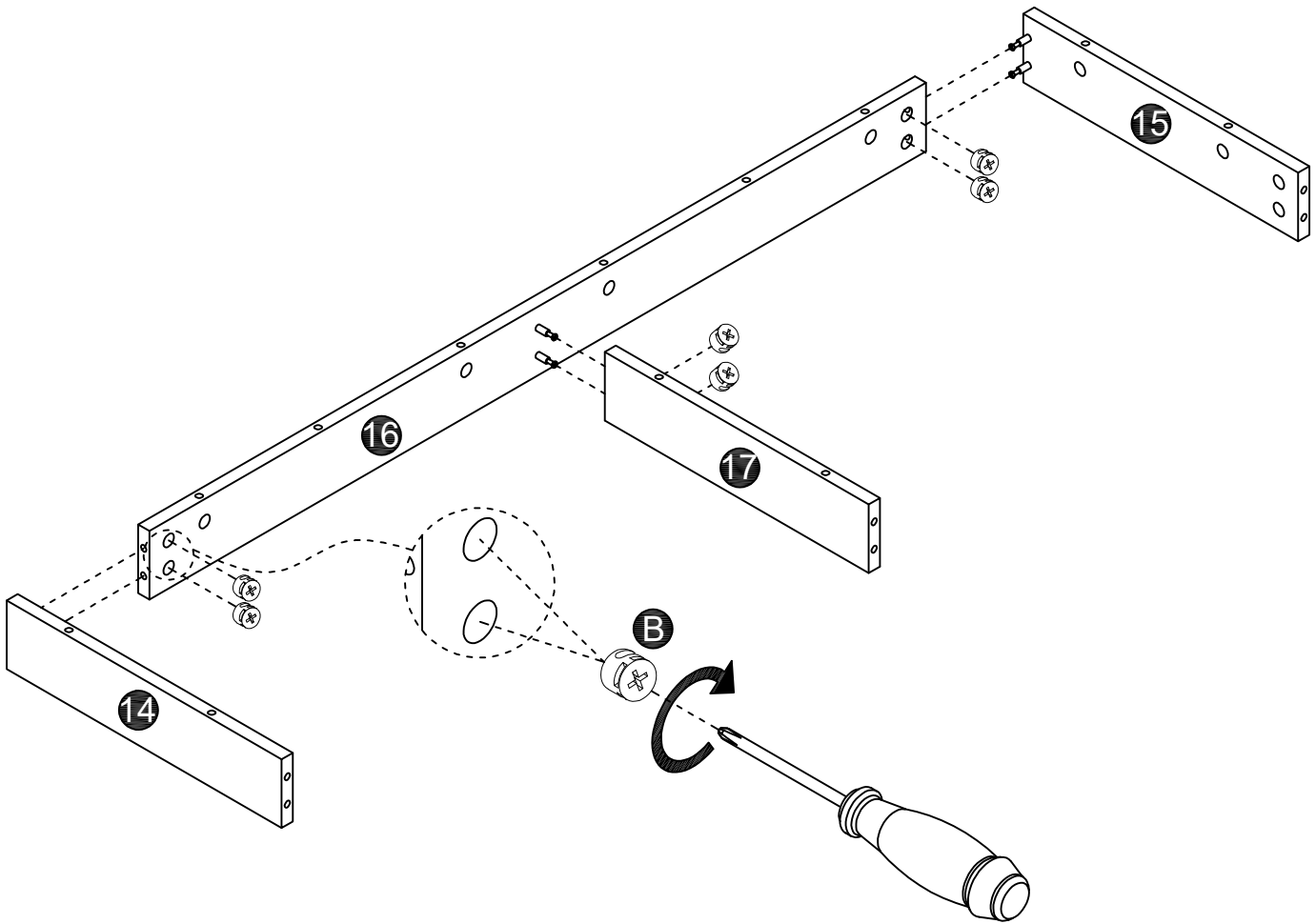
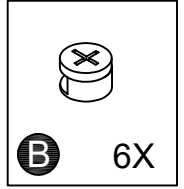

STEP 3

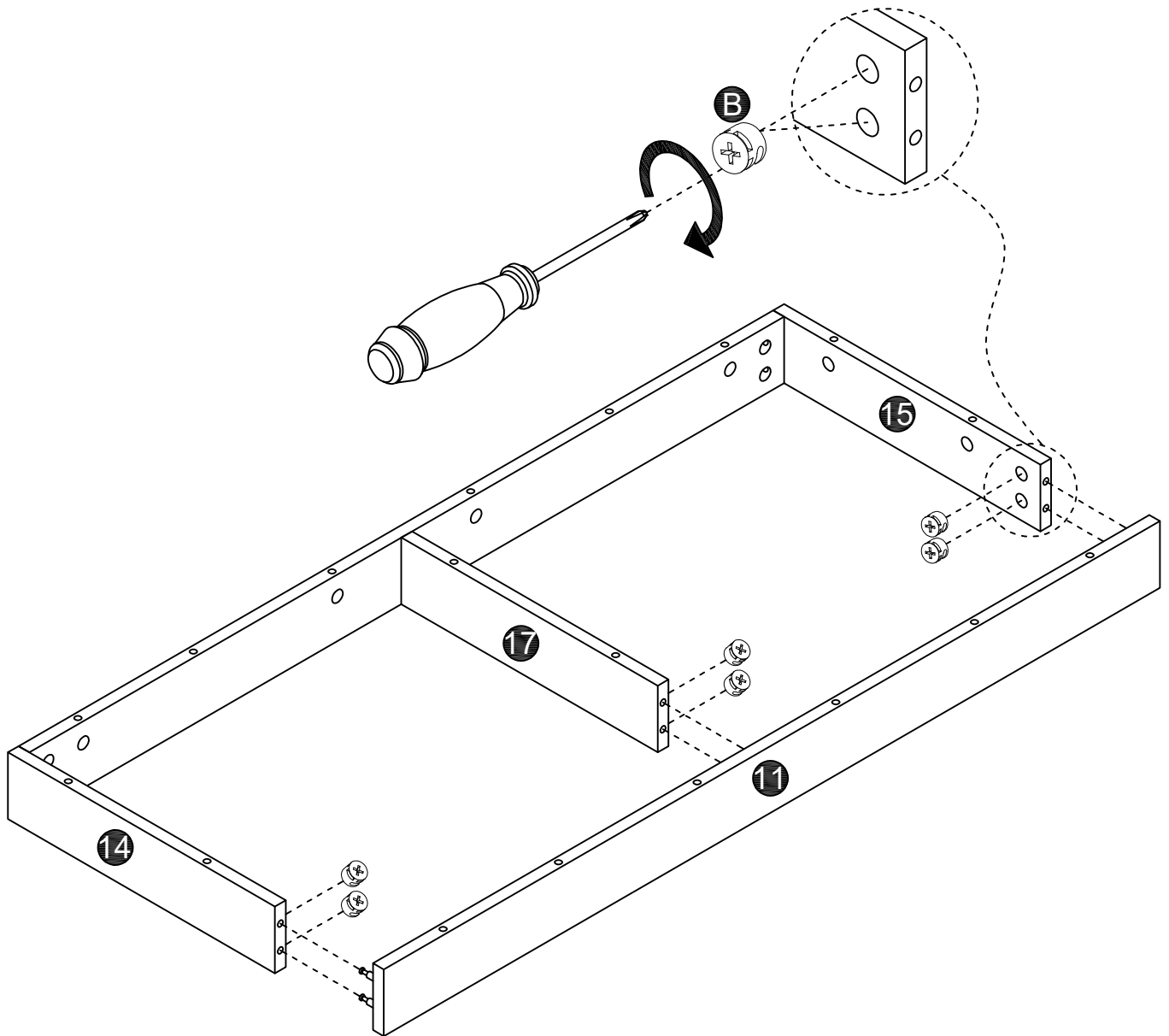
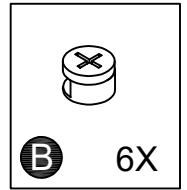

STEP 4

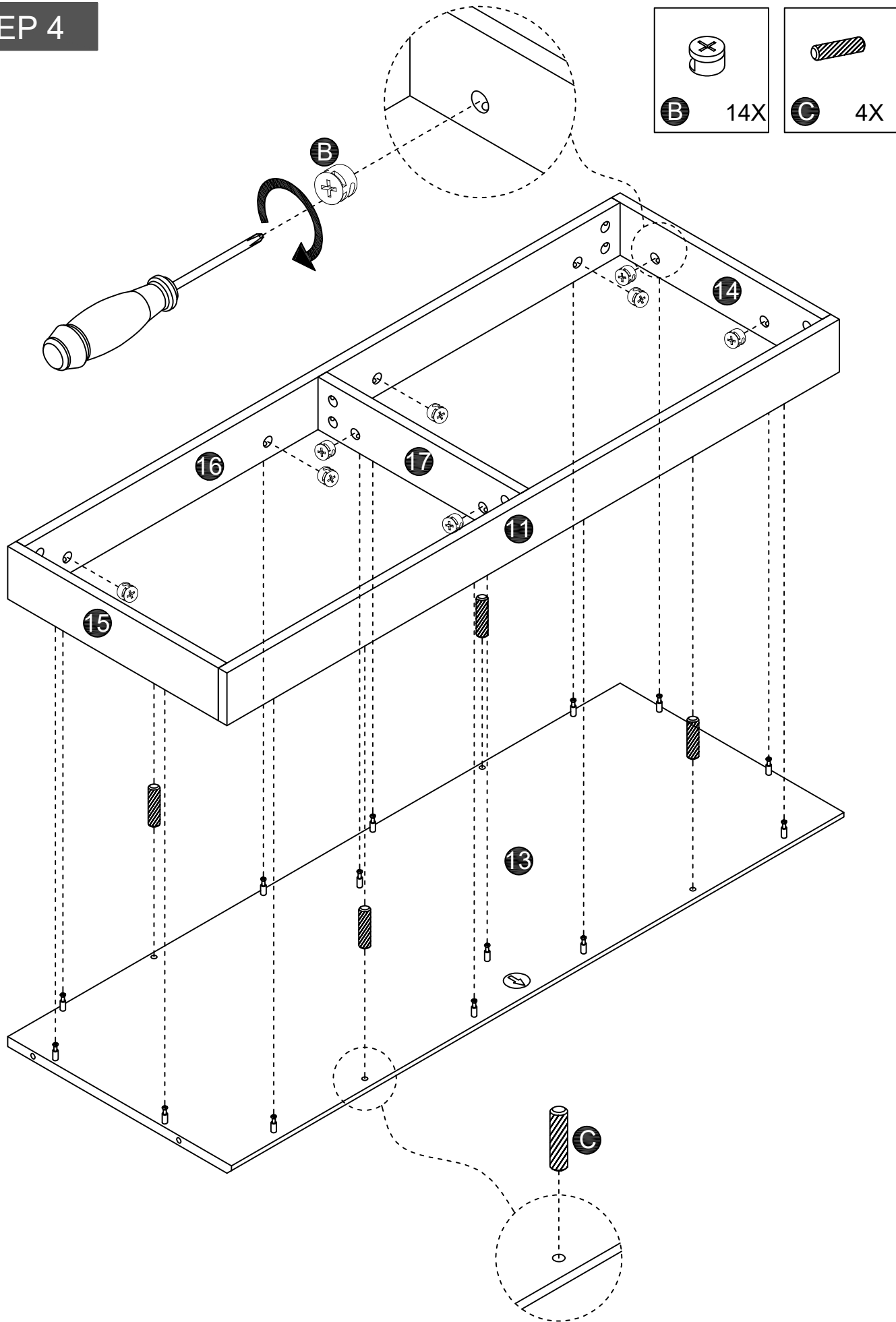

STEP 5

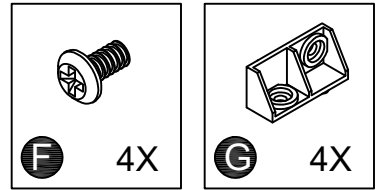
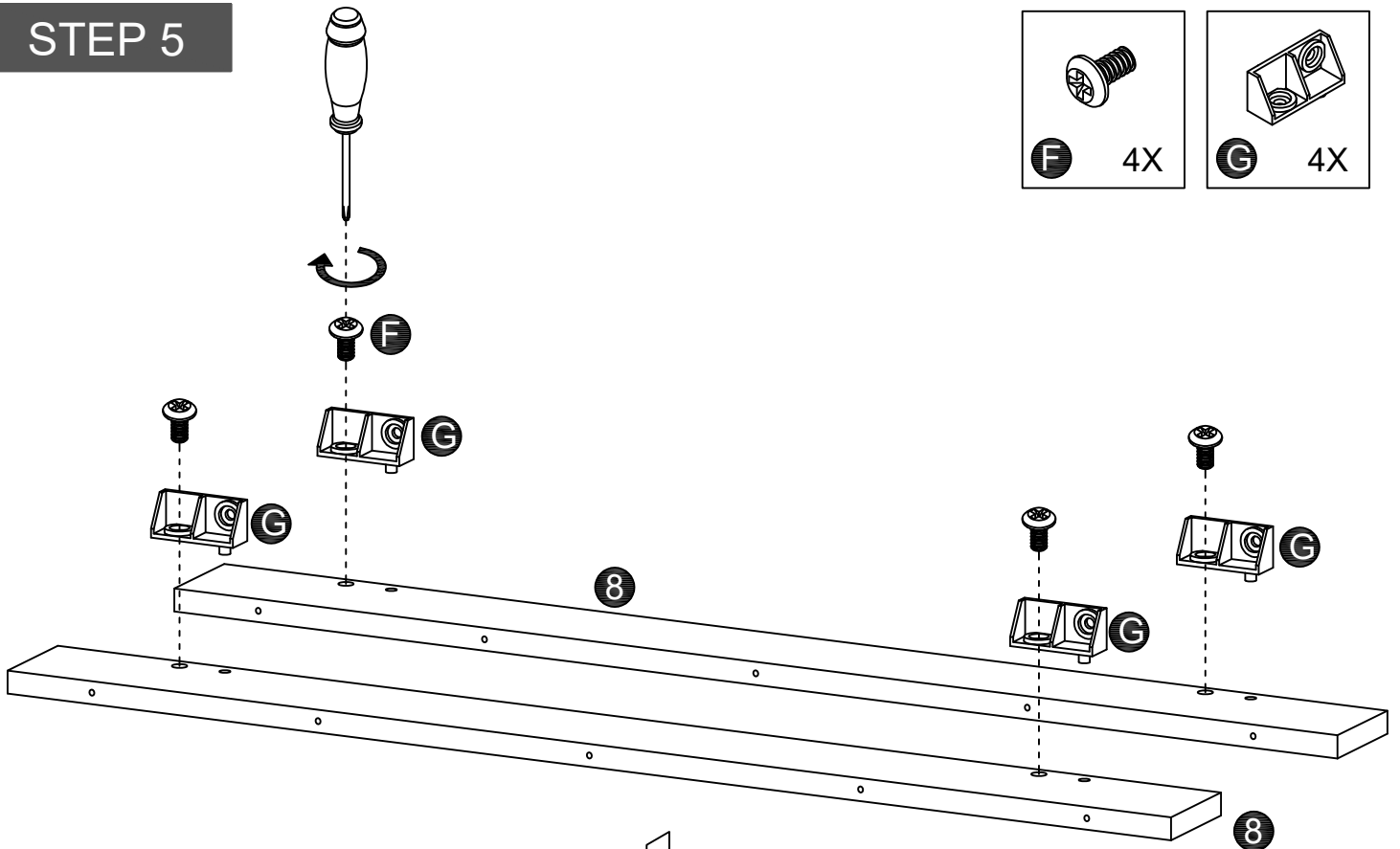

When installing part G, the short side of the 20mm should be flush with the edge of the plank.

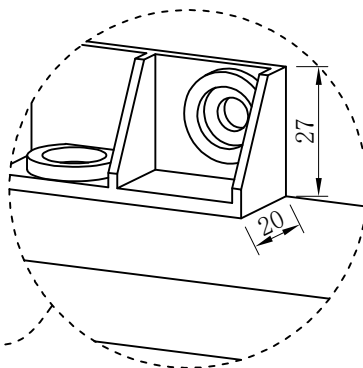

20mm Flush with the plank

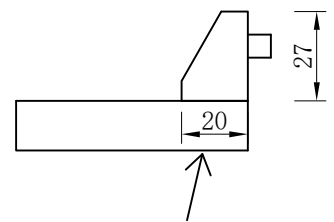

The final appearance after assembling part G

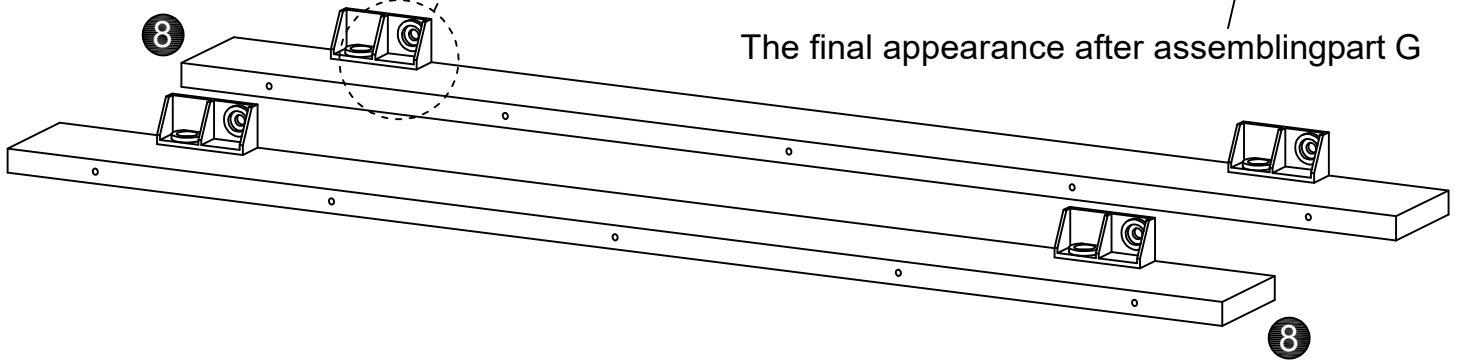

STEP 6

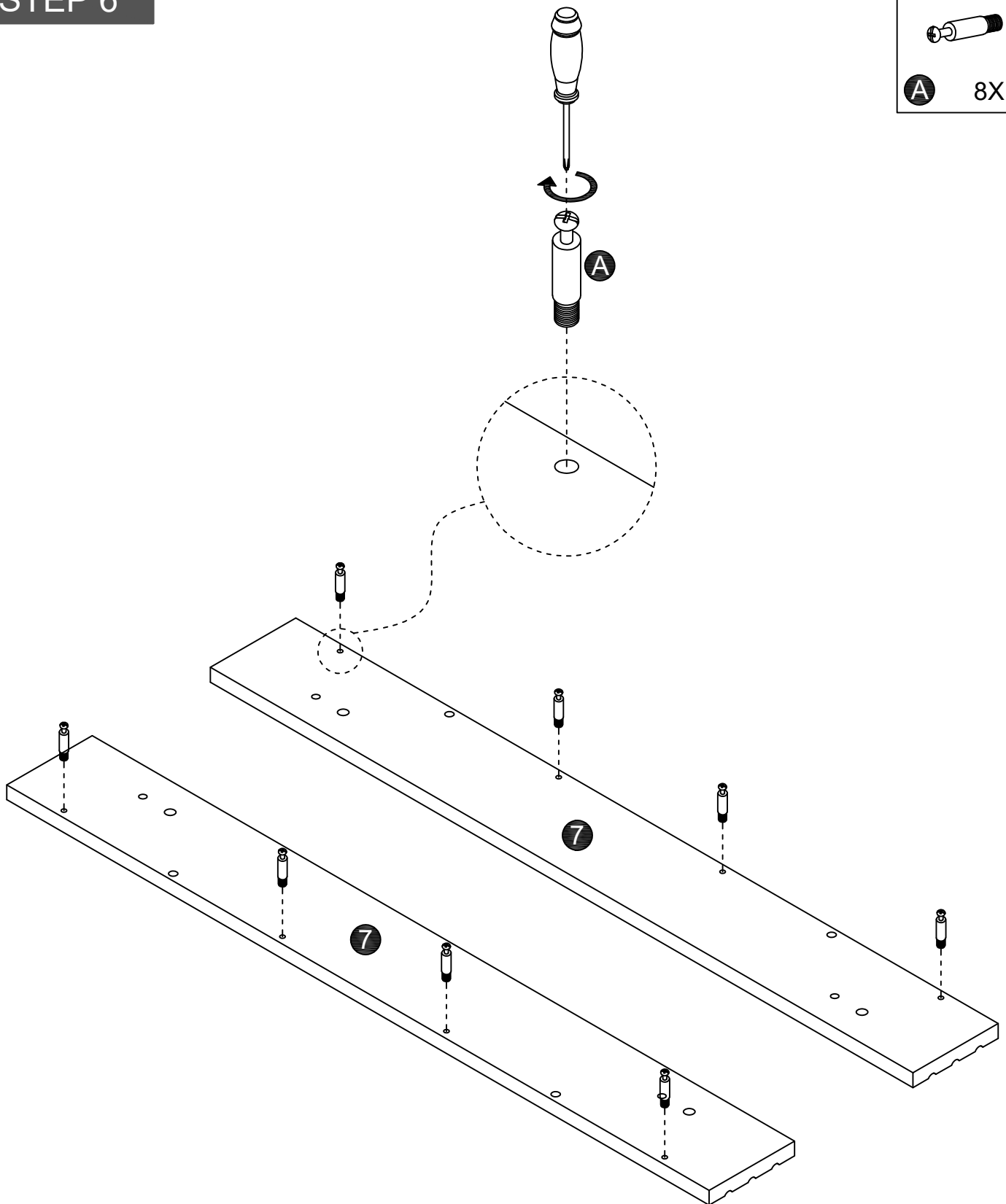
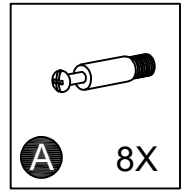

STEP 7

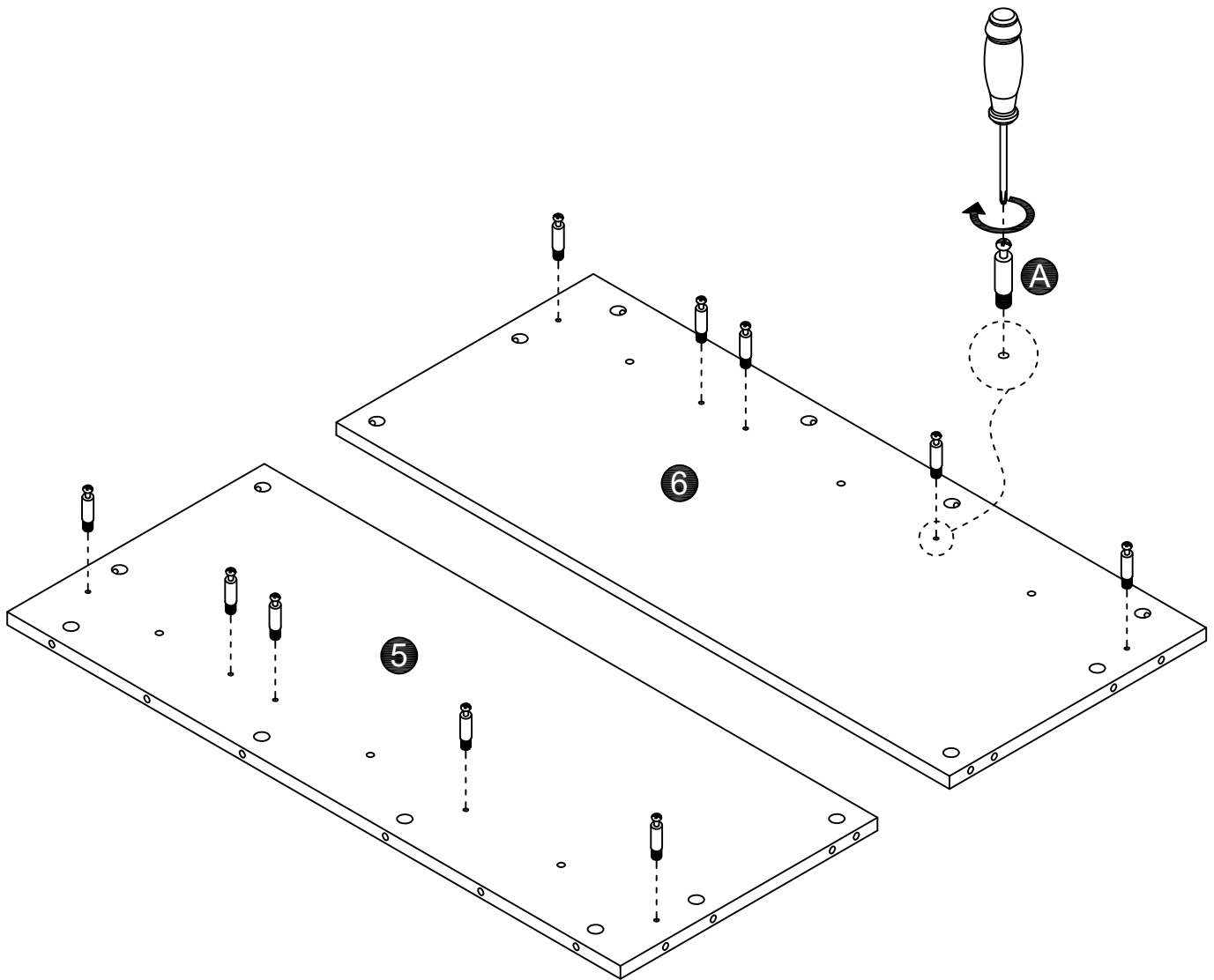
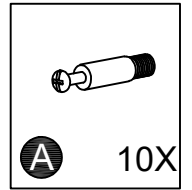

STEP 8

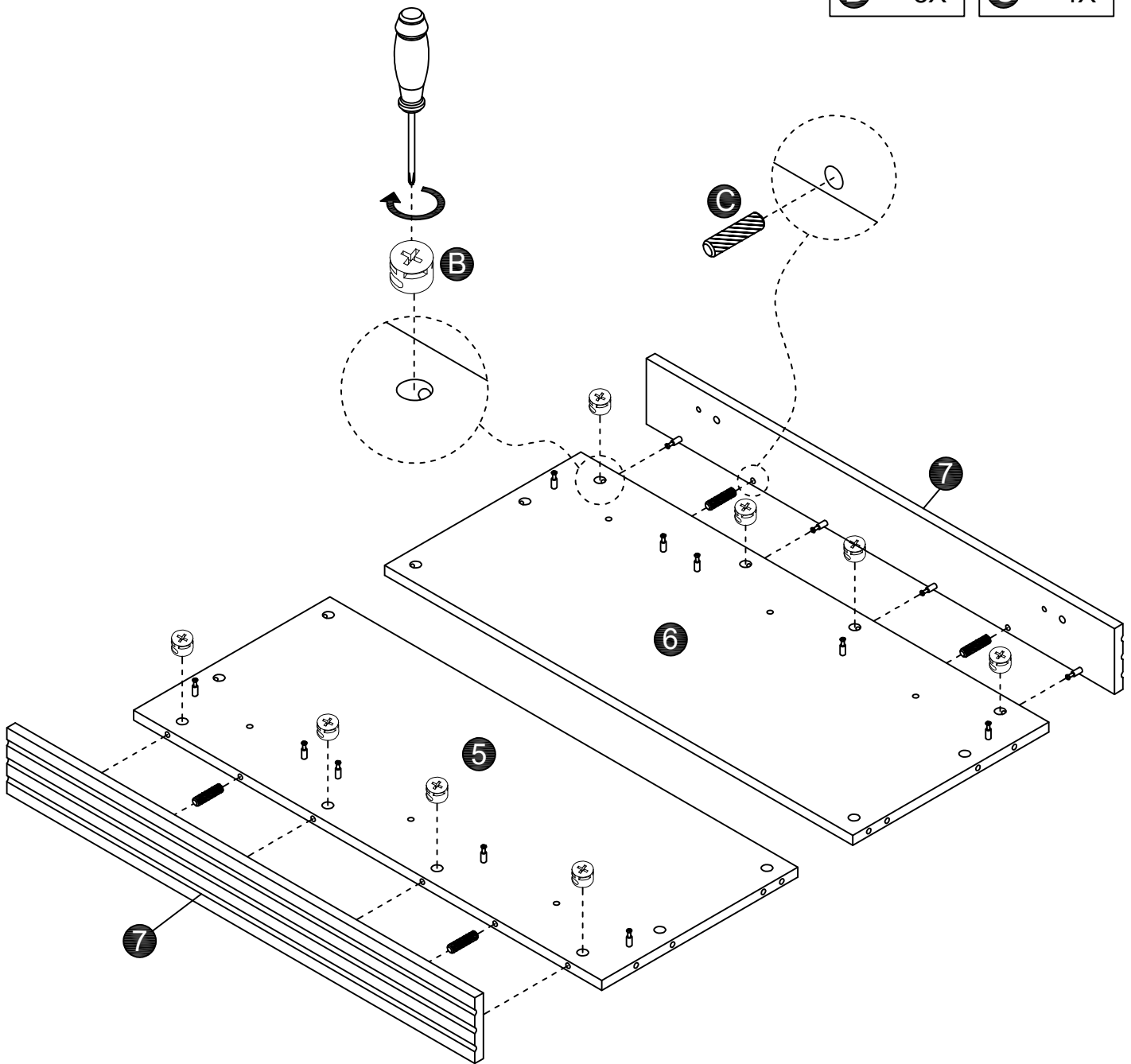
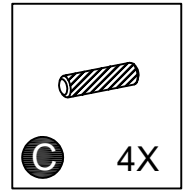
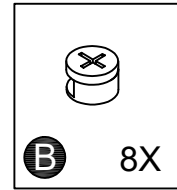

STEP 9

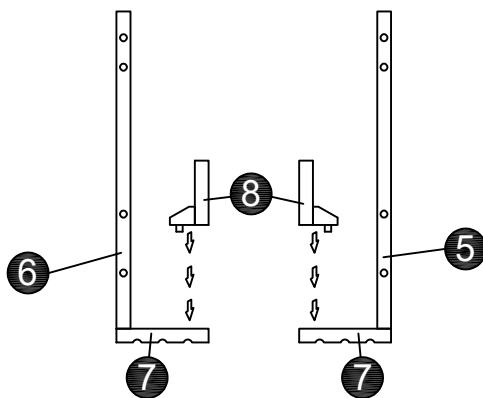
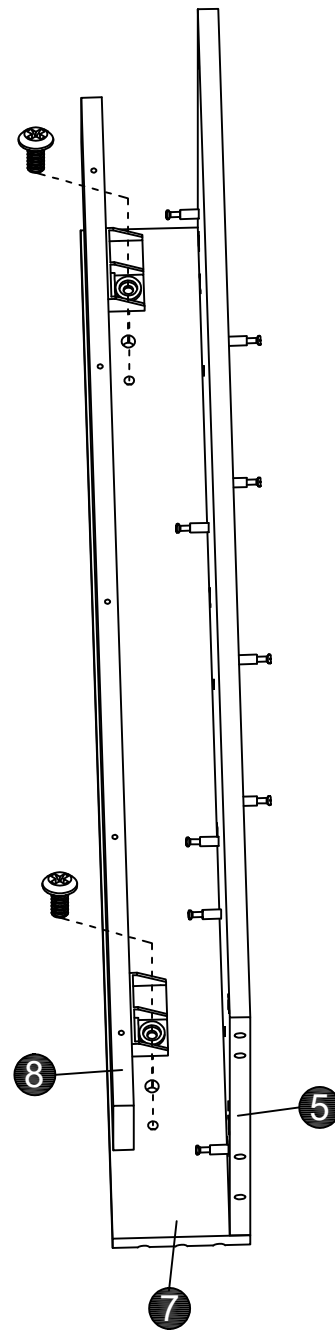
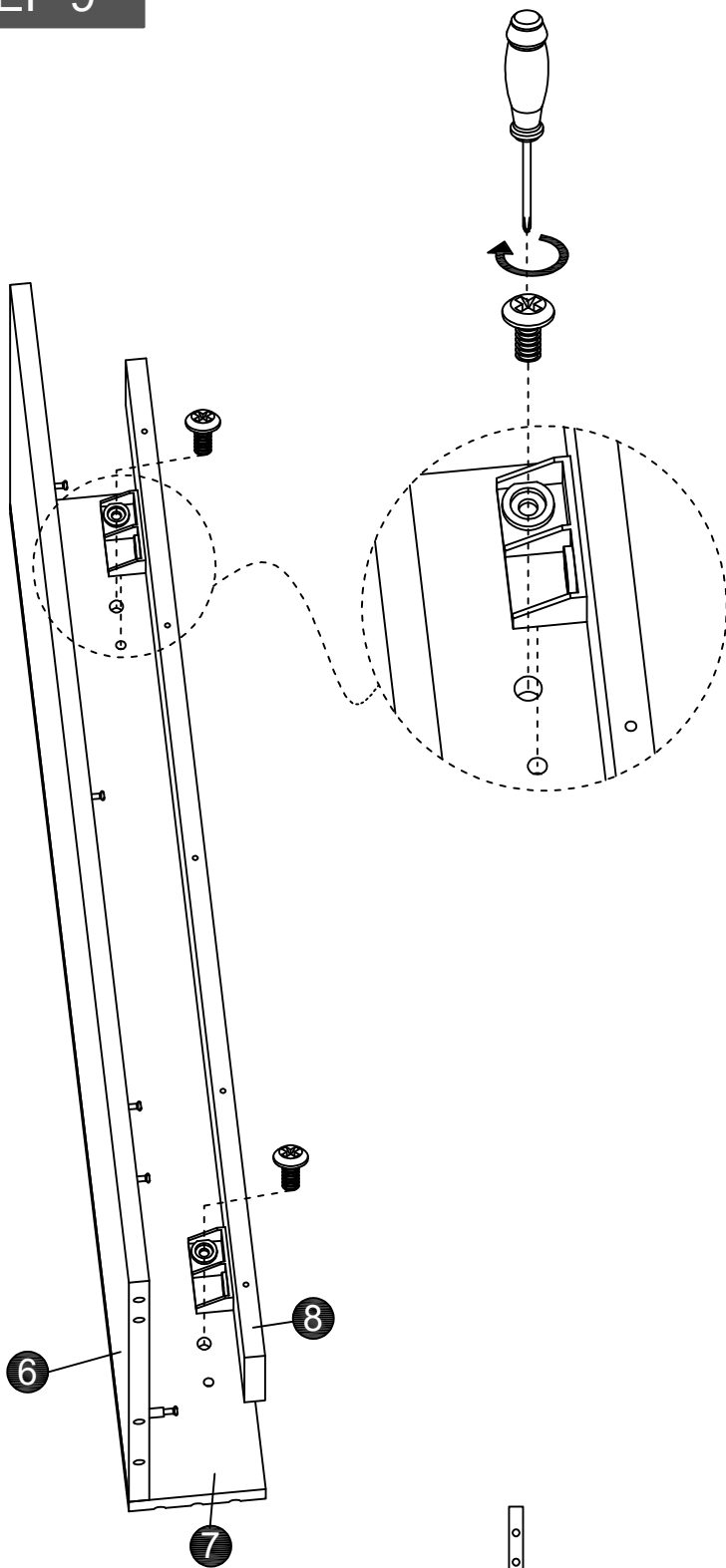
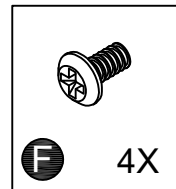

STEP 10

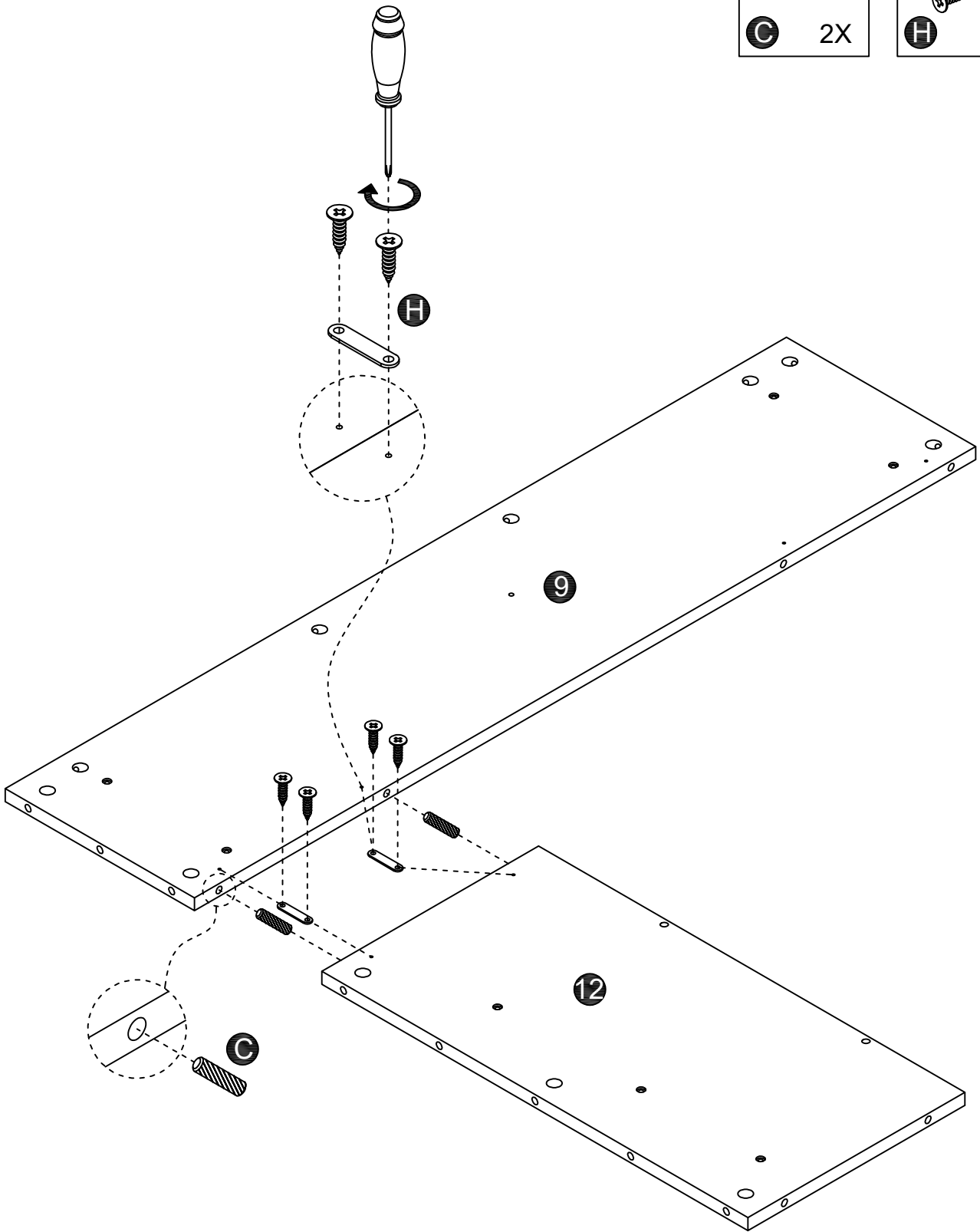
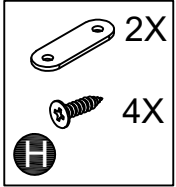
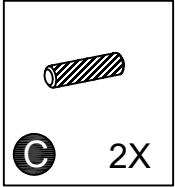

STEP 12

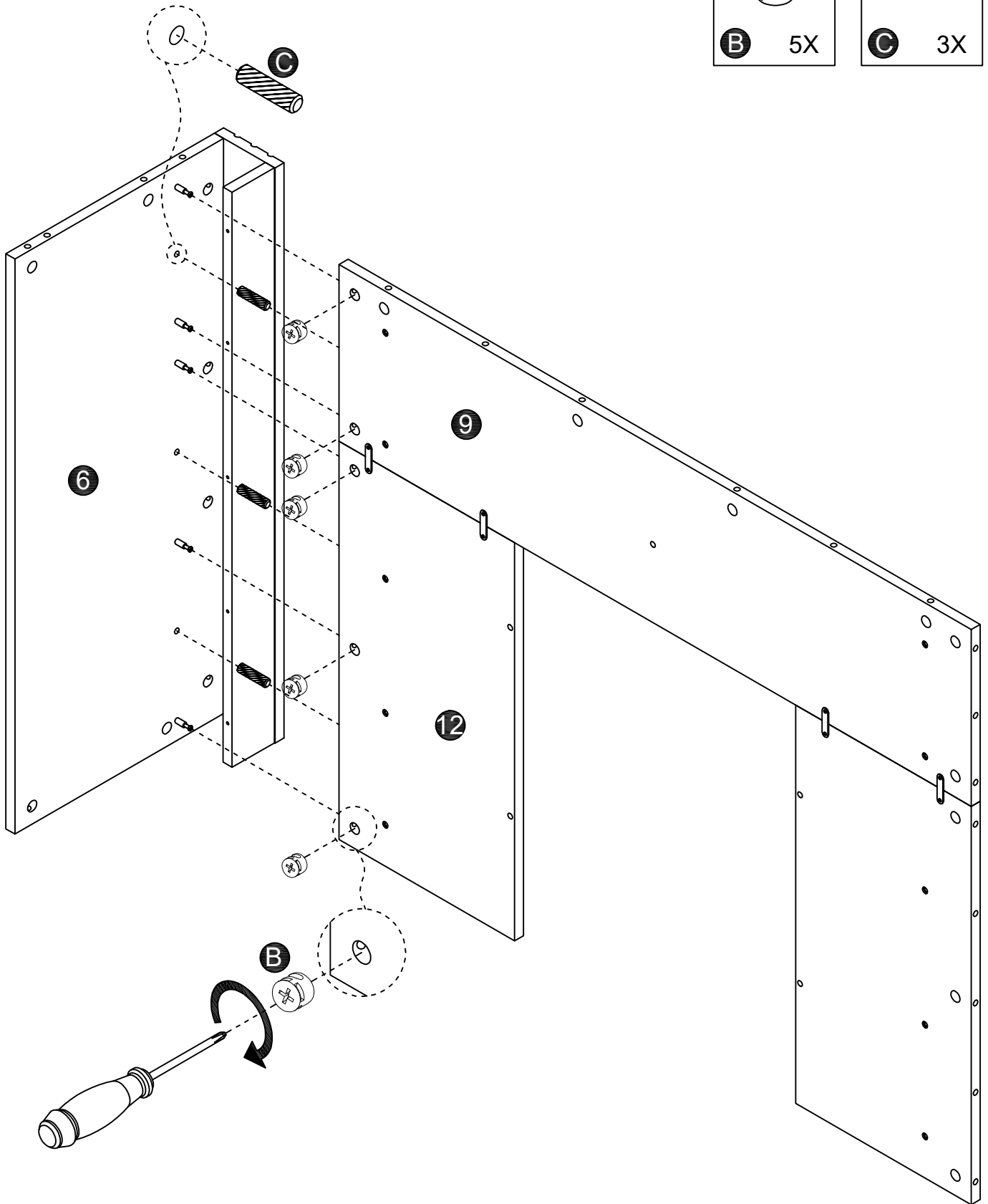
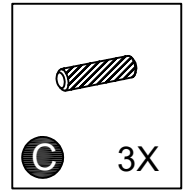
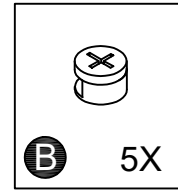

STEP 13

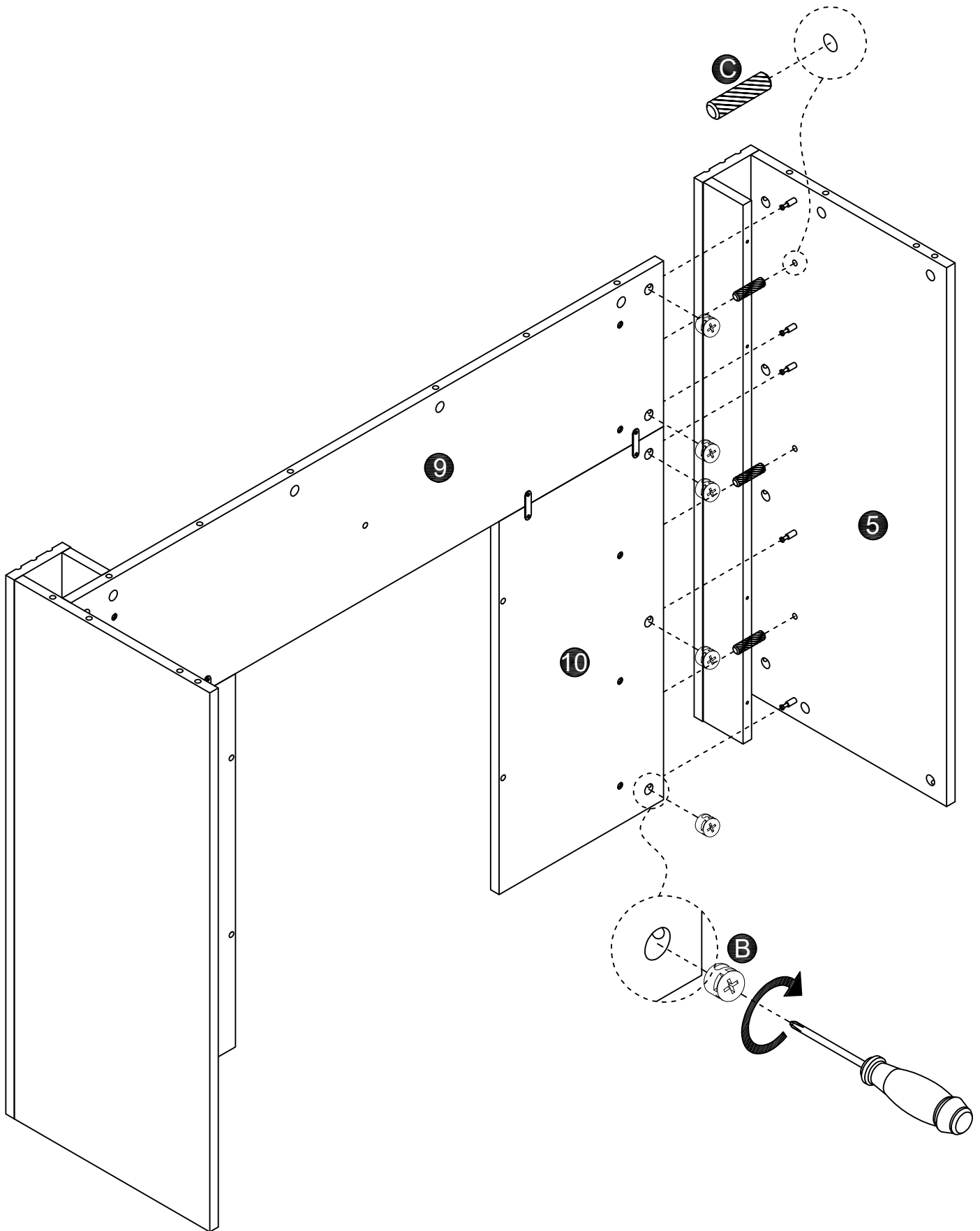
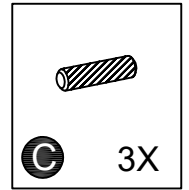
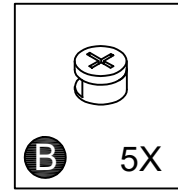

STEP 14

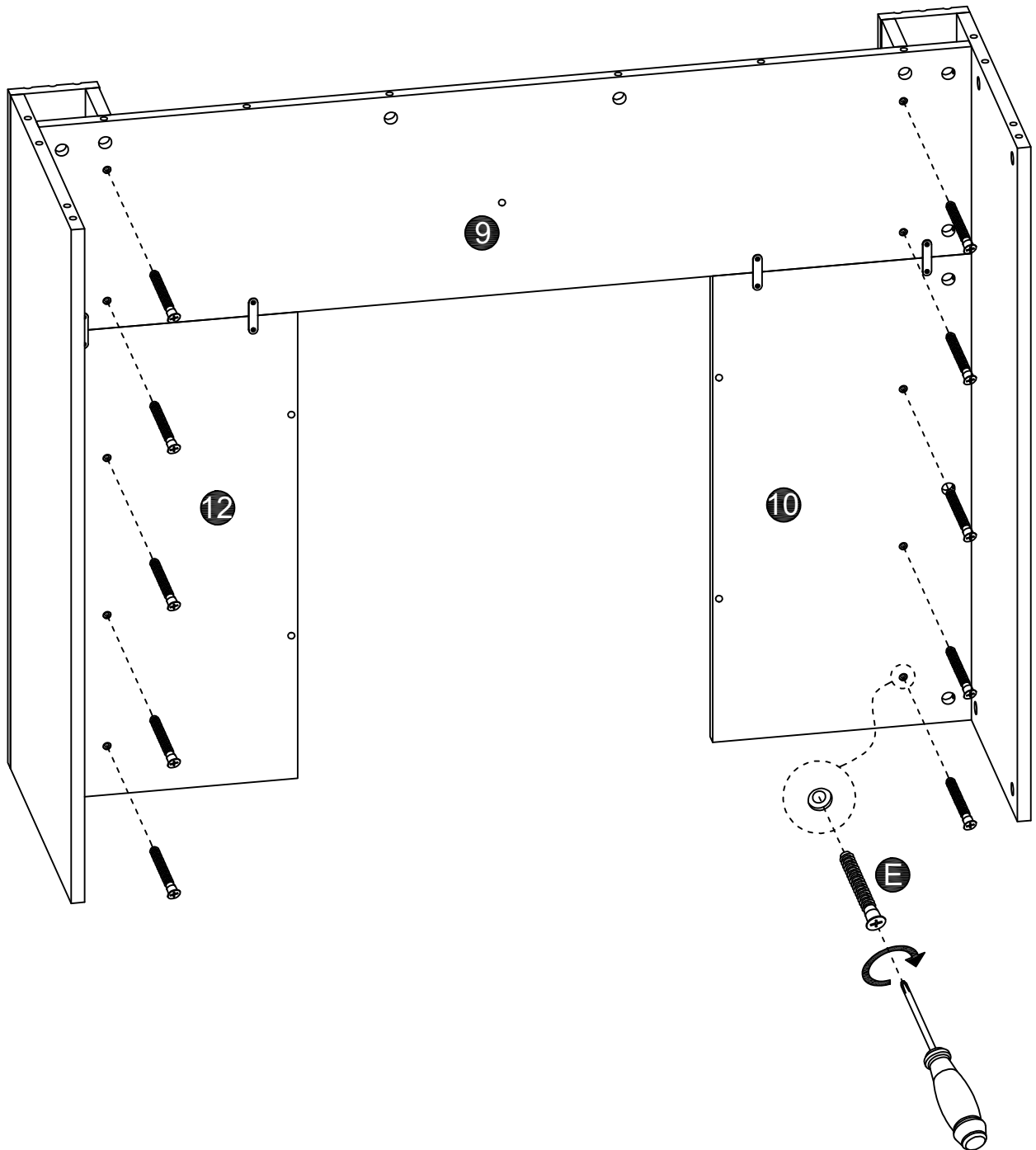
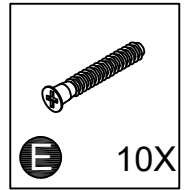

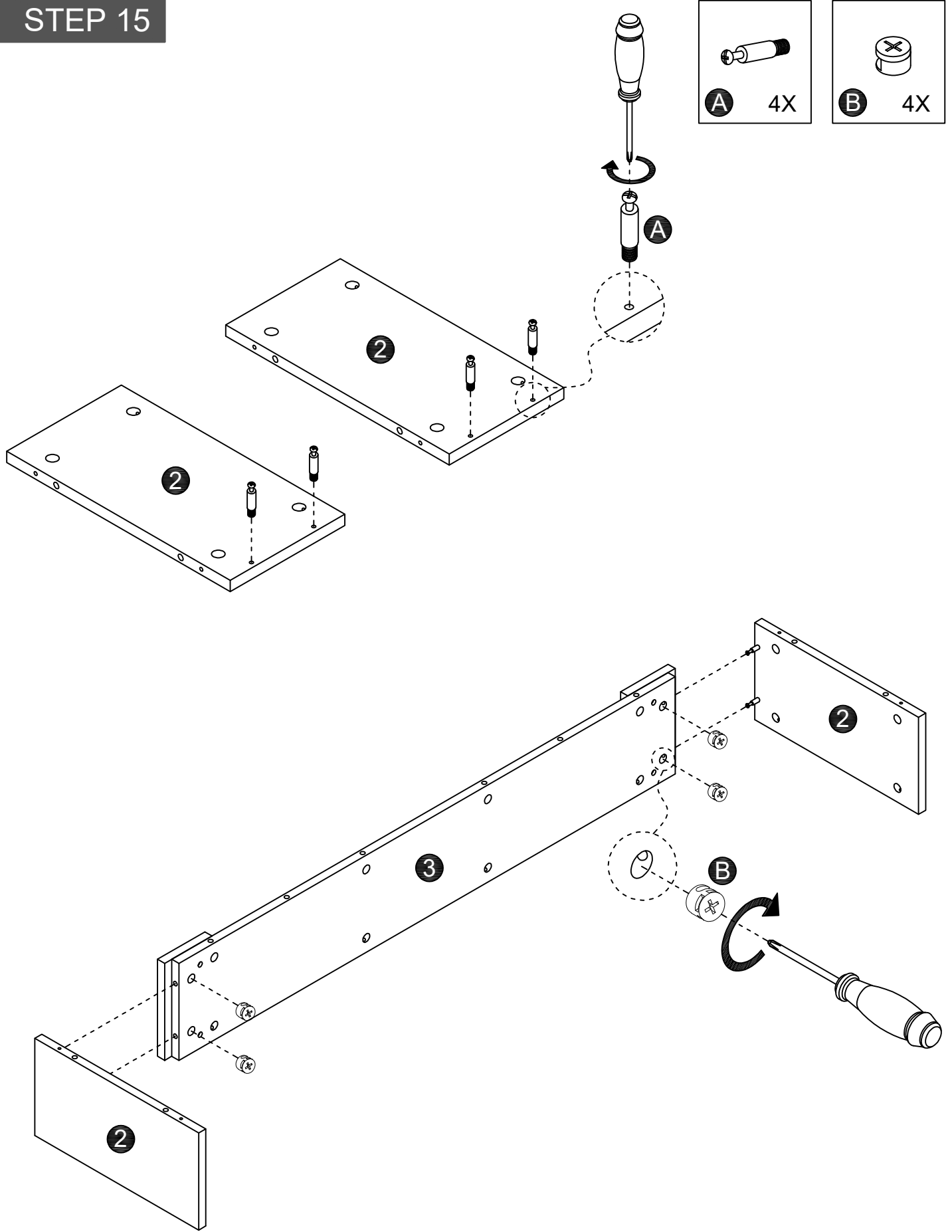

STEP 15

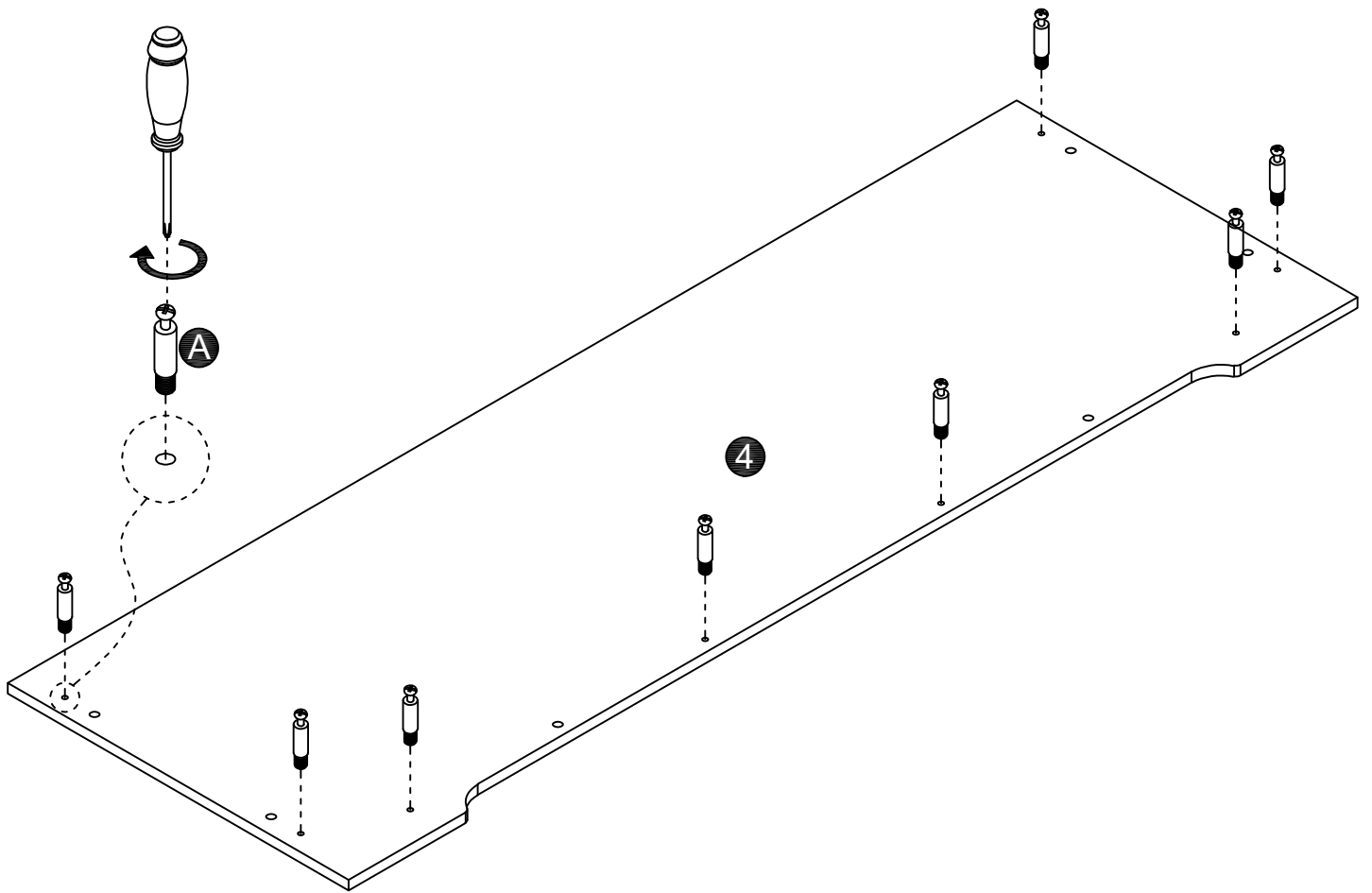
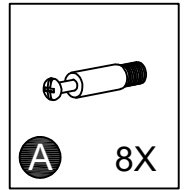

STEP 16



STEP 17

	
B 8X	C 6X

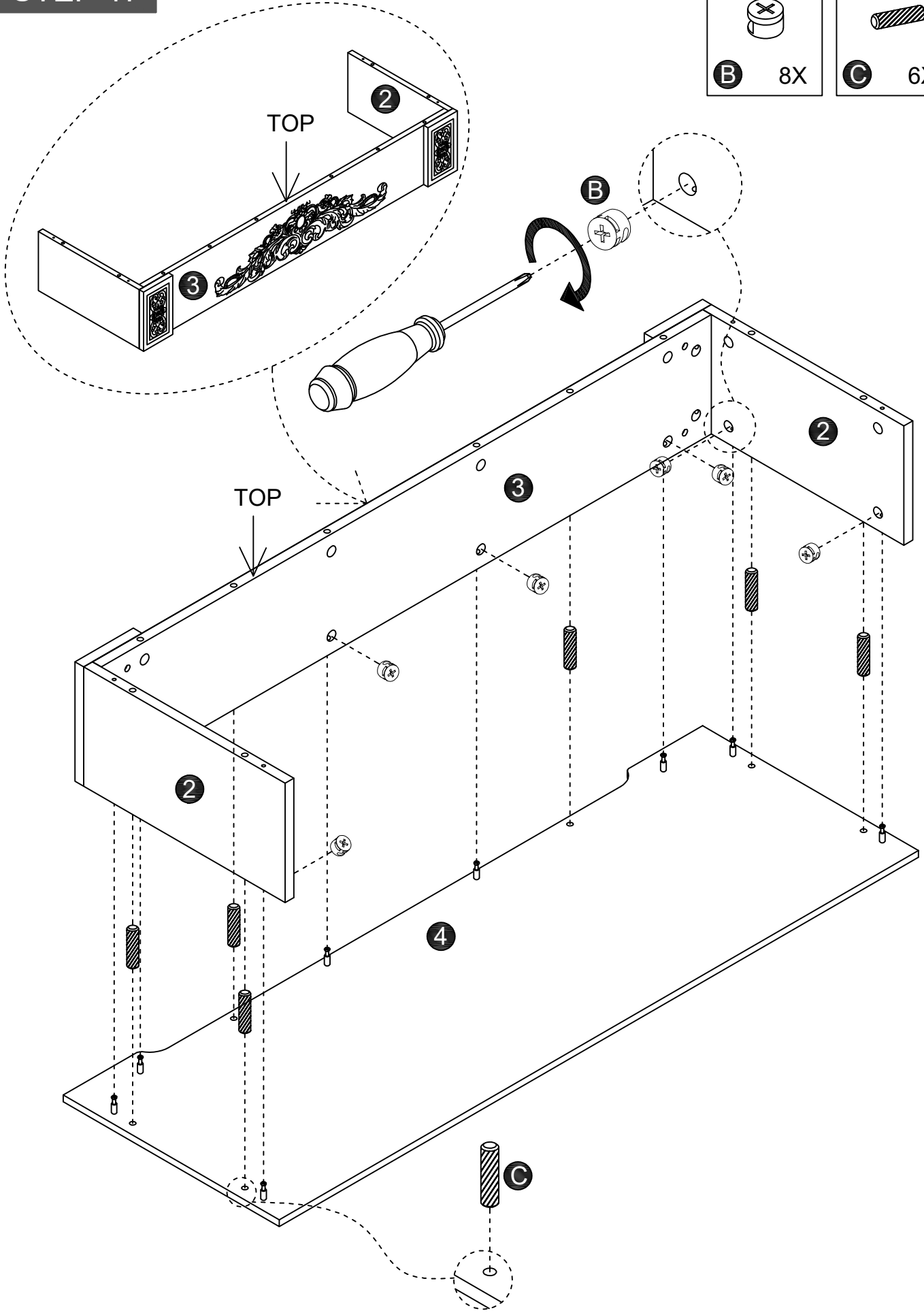

STEP 18

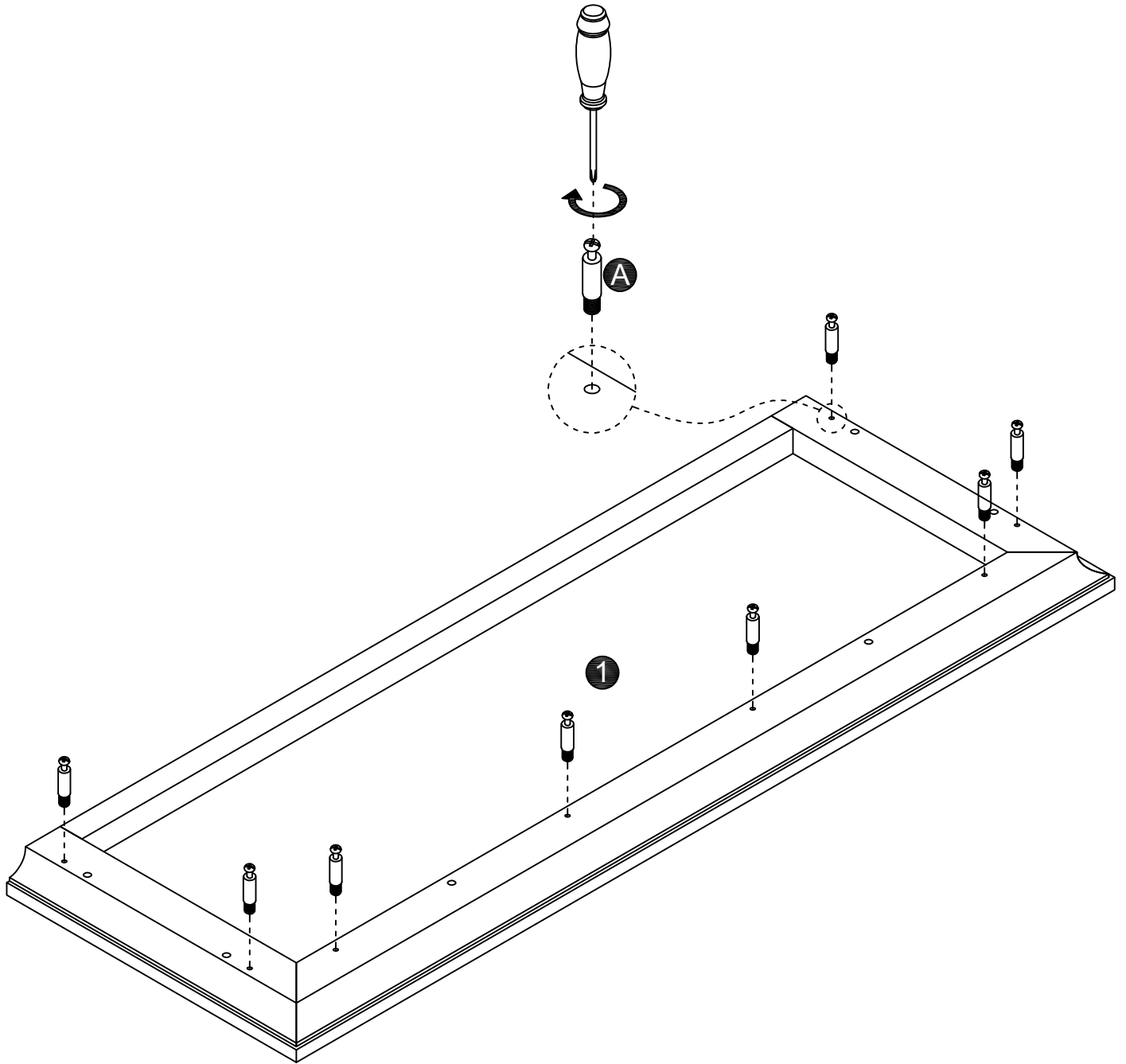
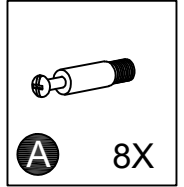

STEP 19

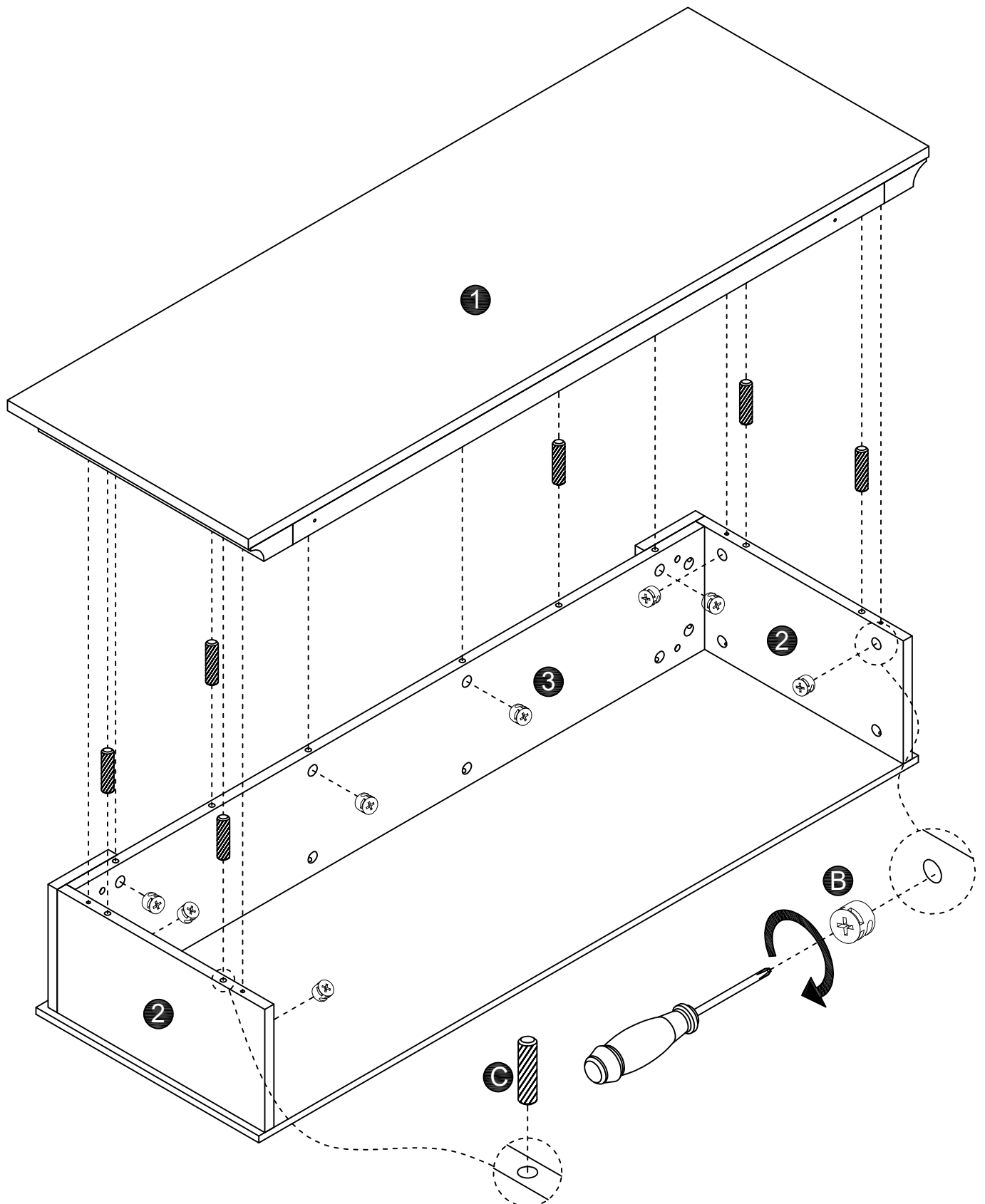
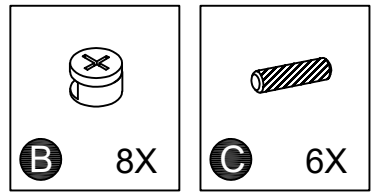

STEP 20

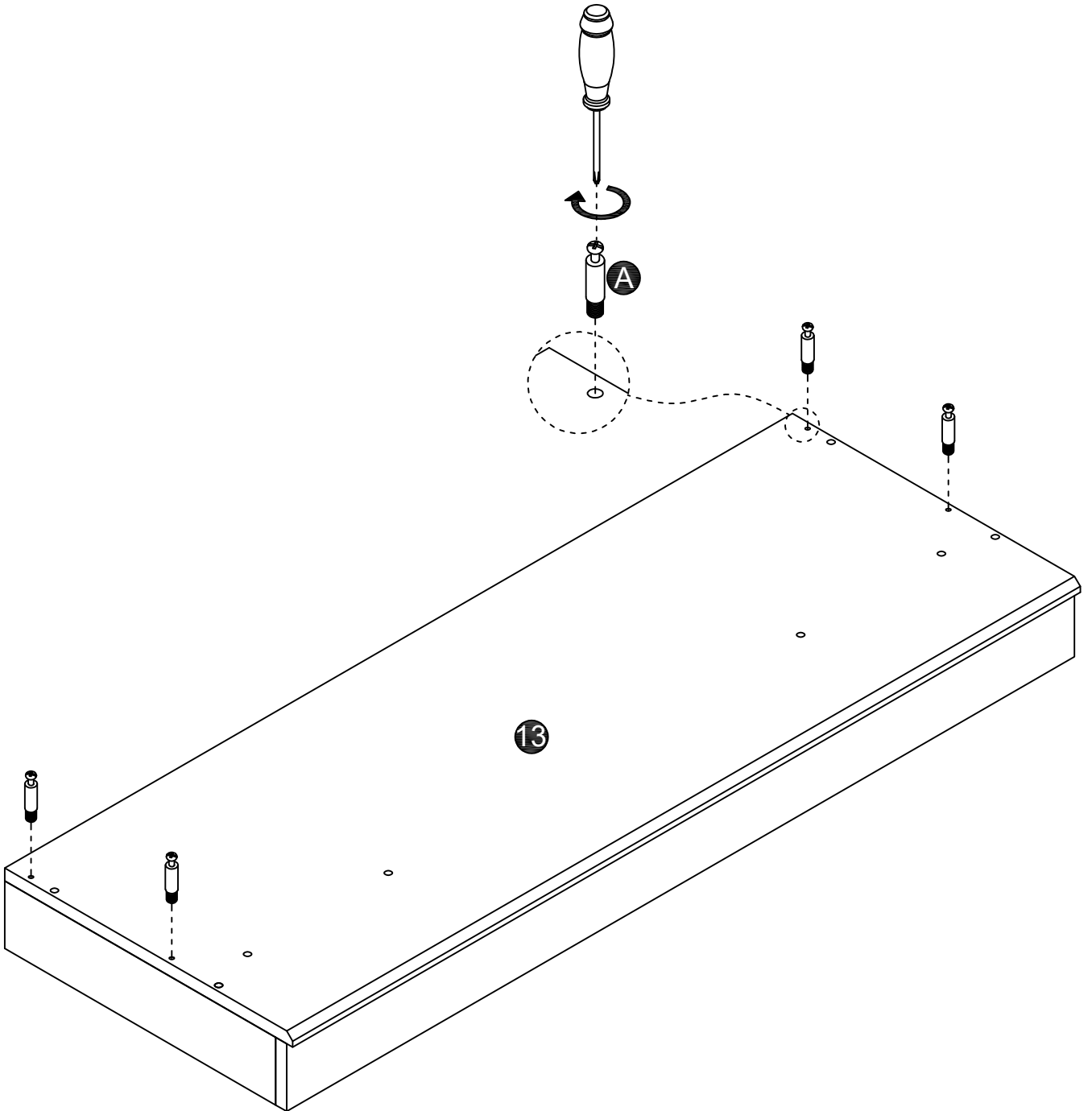
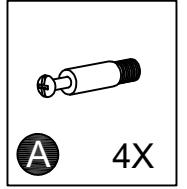

STEP 21

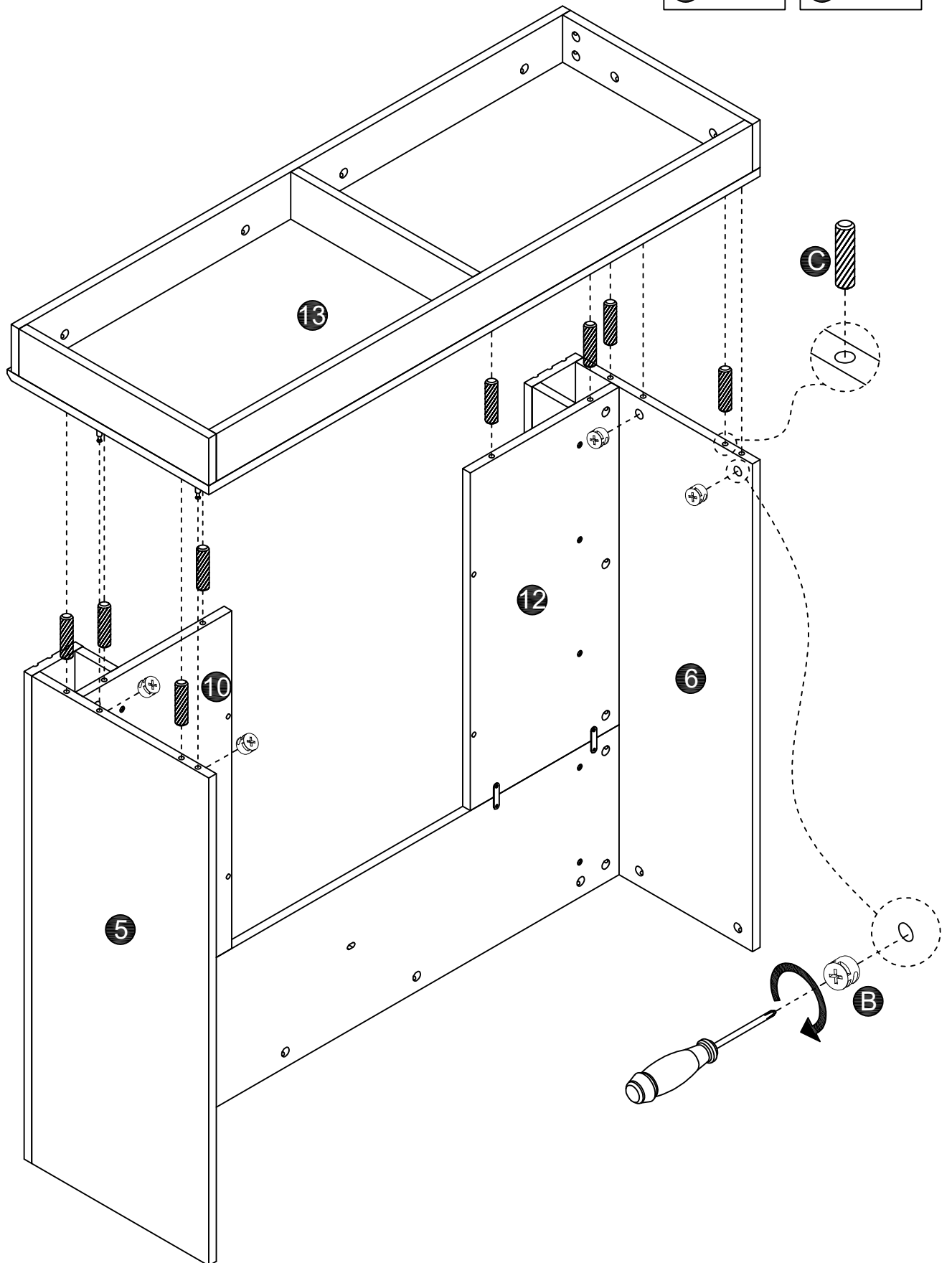
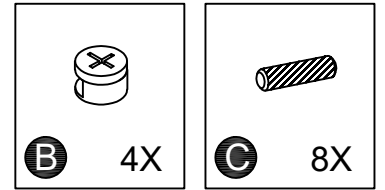

STEP 22

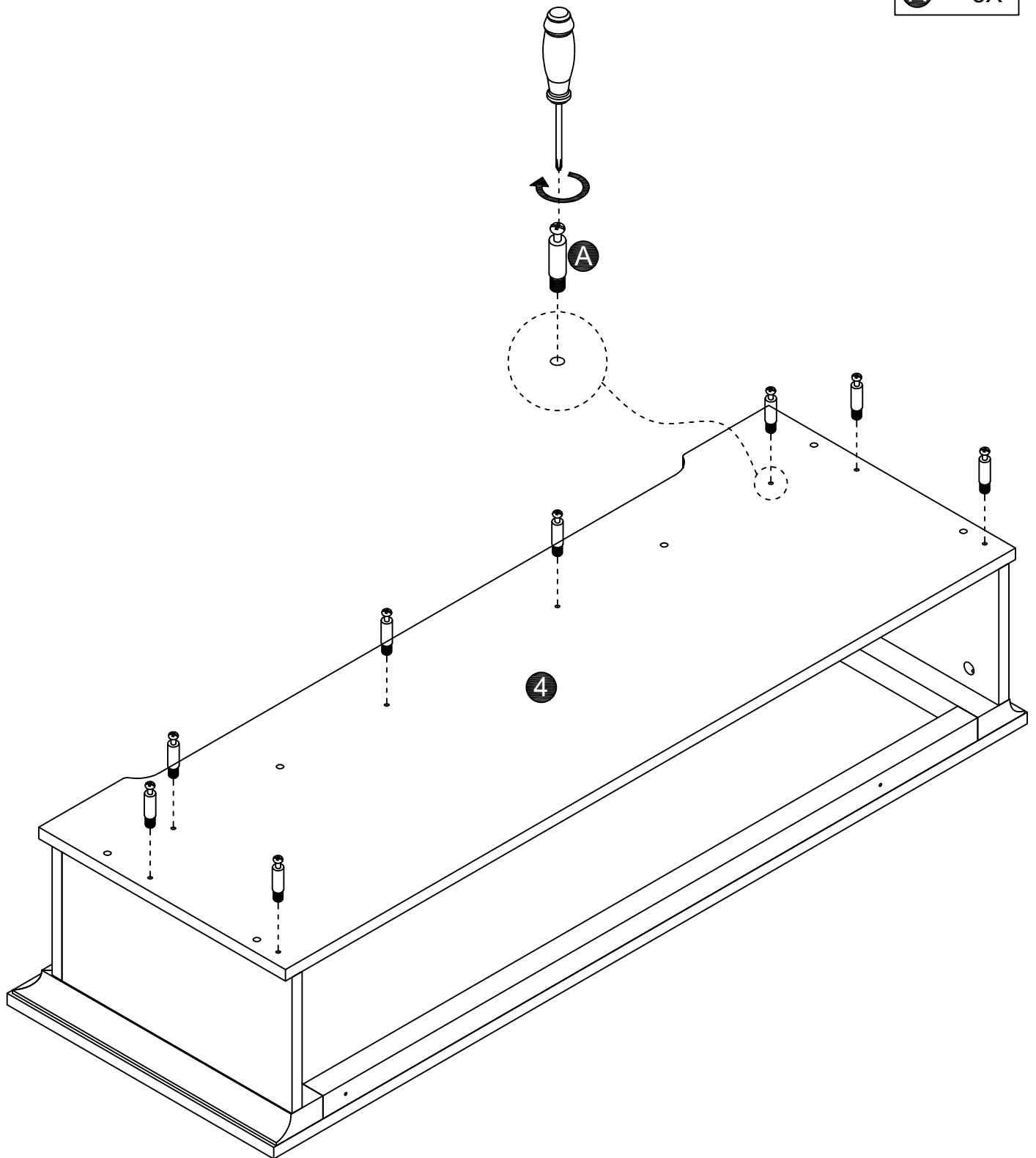
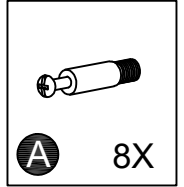

STEP 23

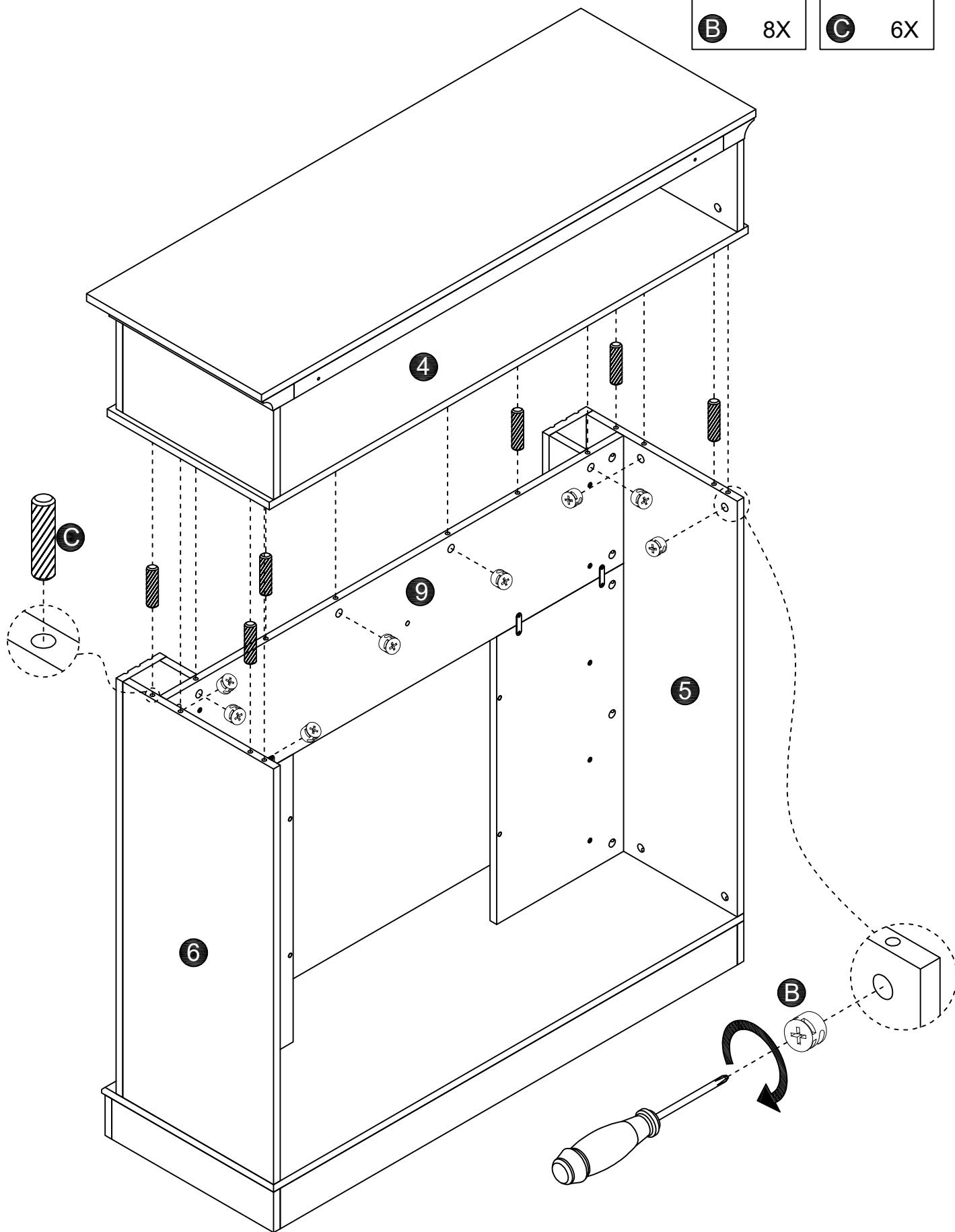
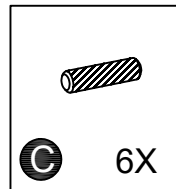
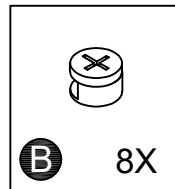

STEP 24

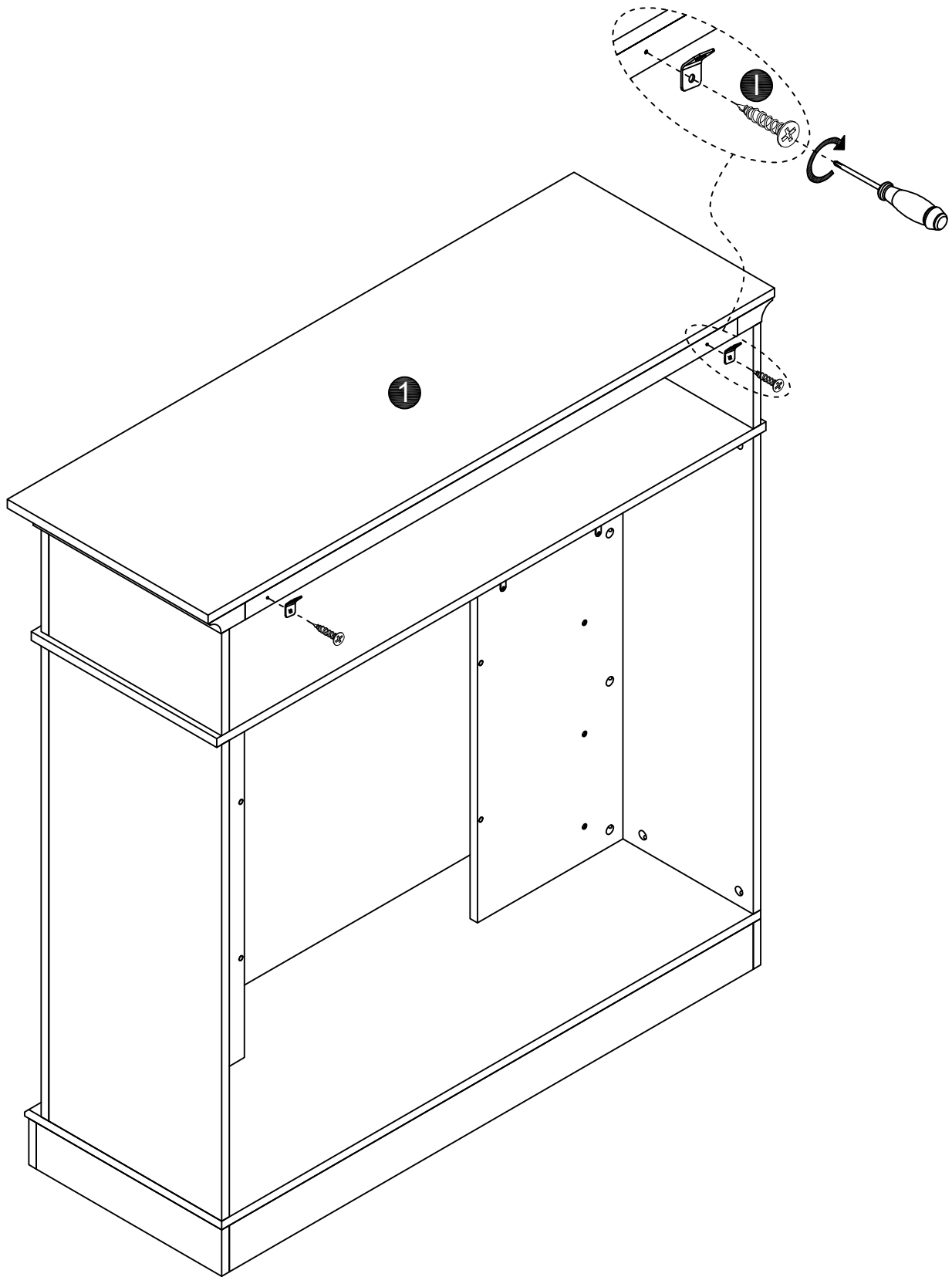
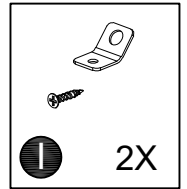

STEP 25

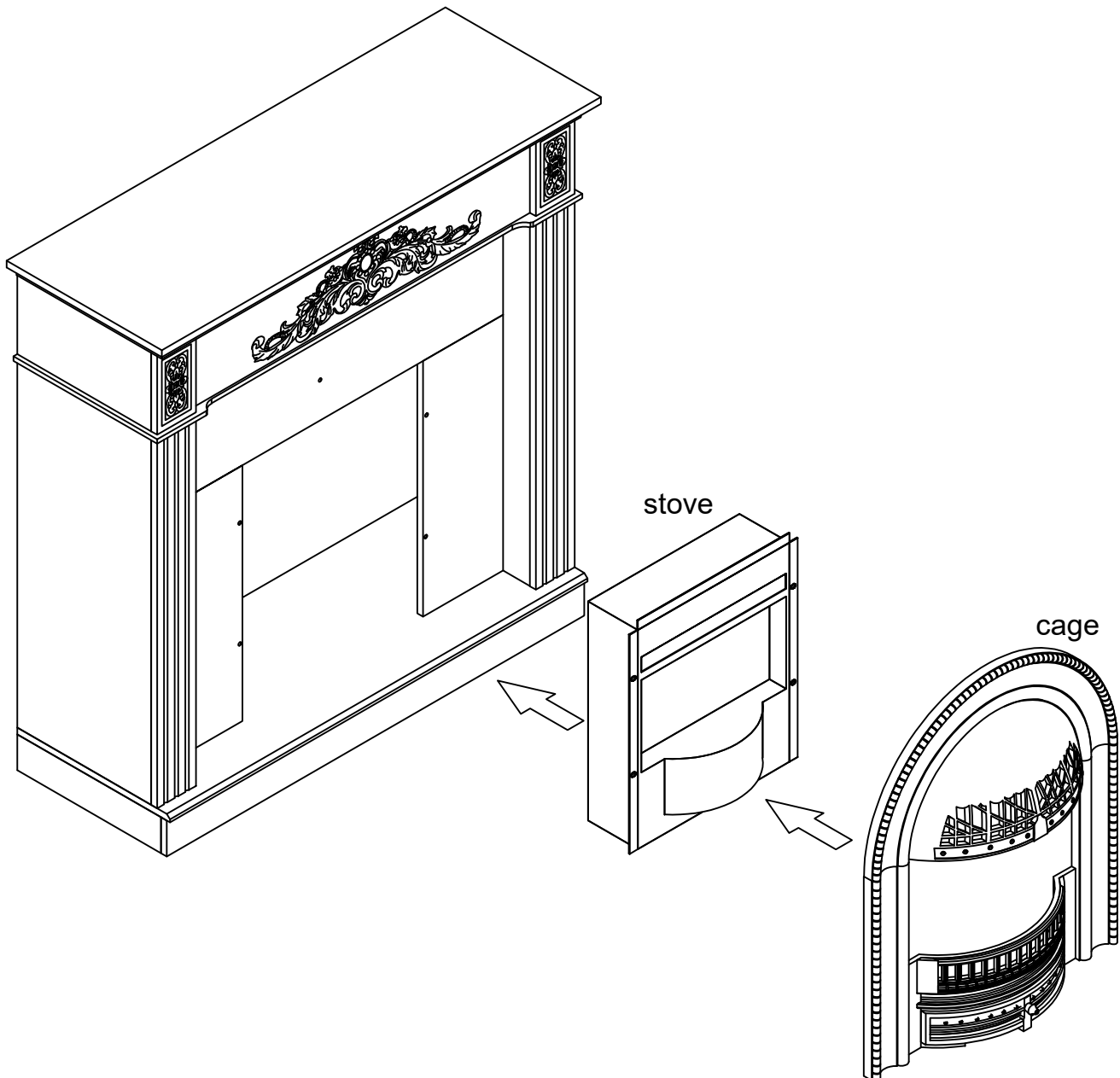
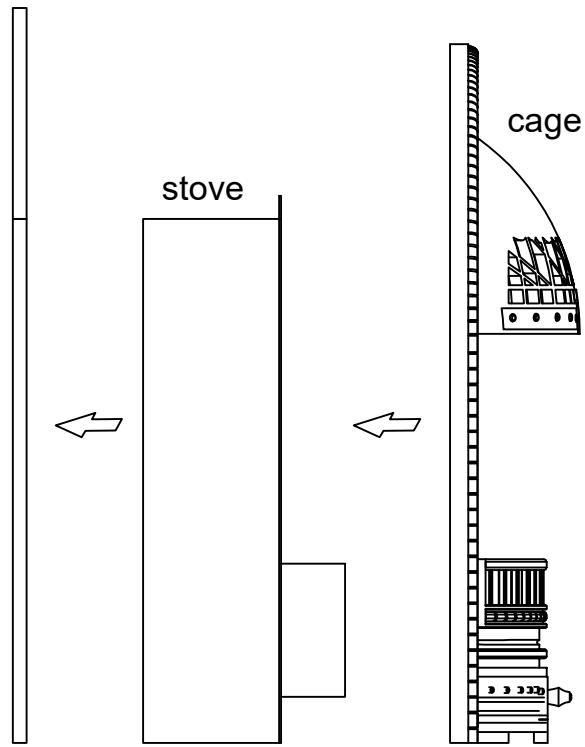

STEP 26

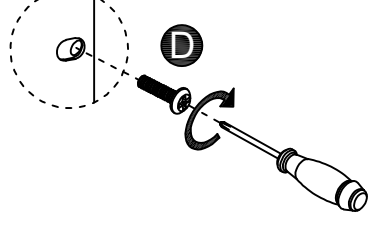
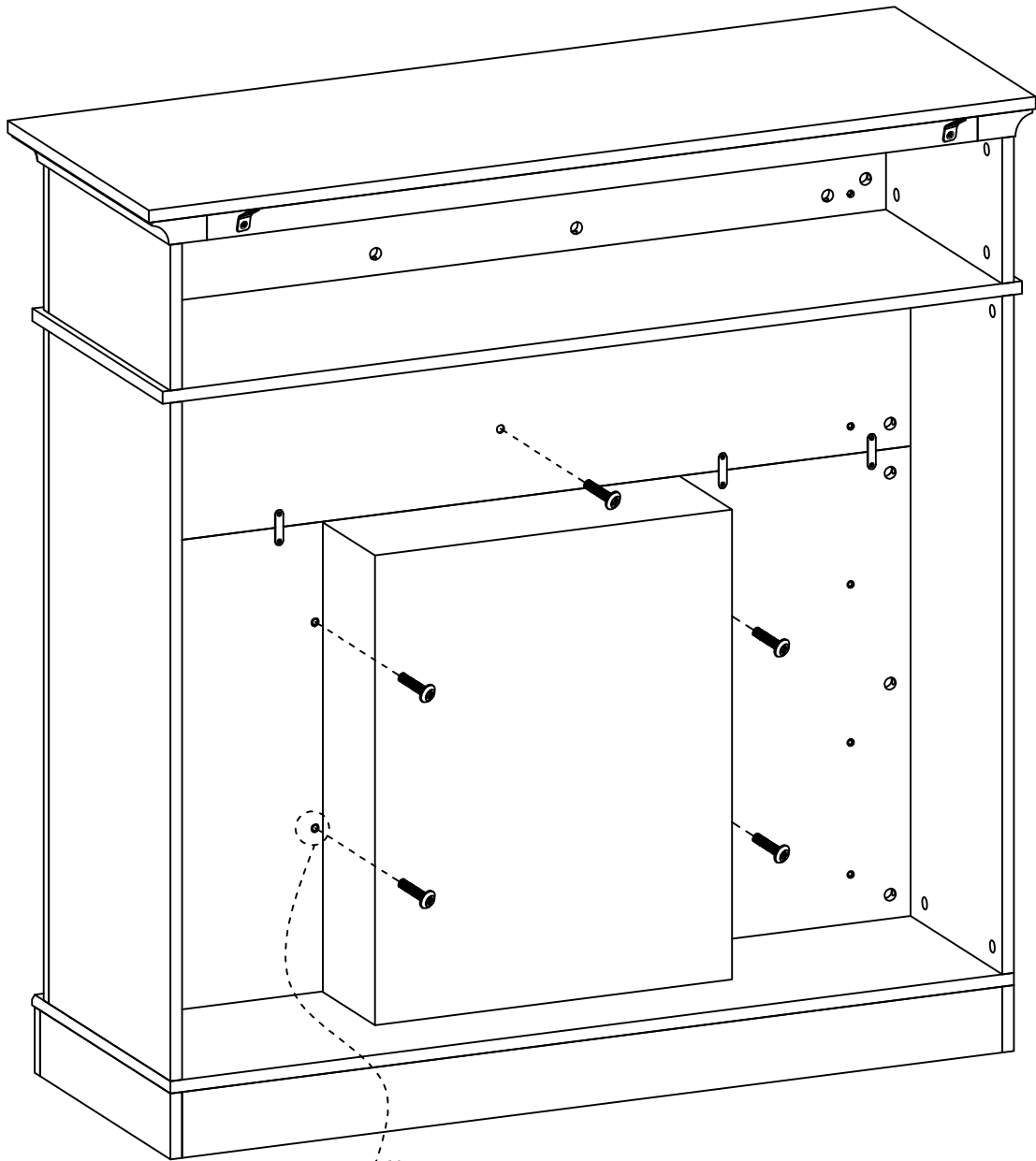
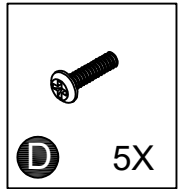

STEP 27

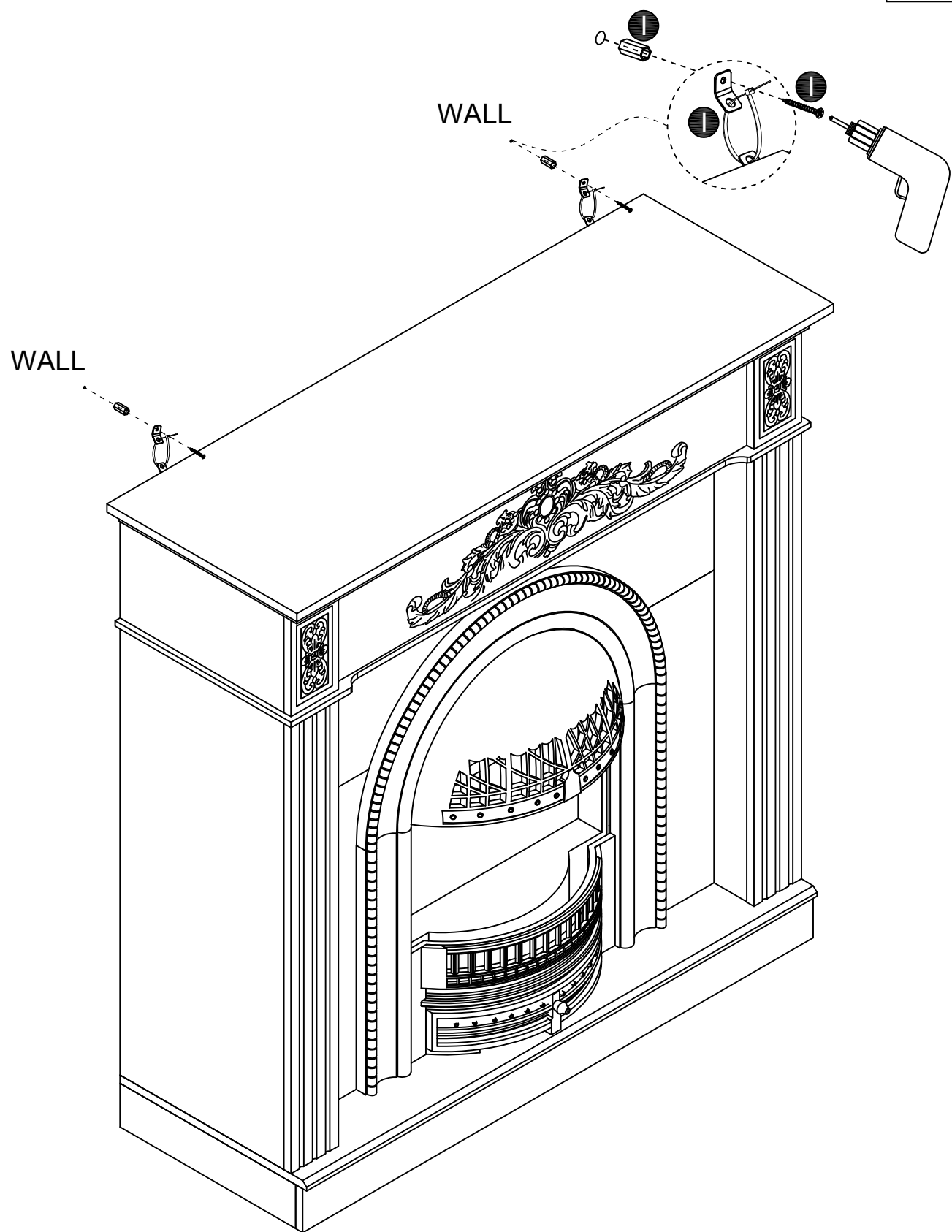
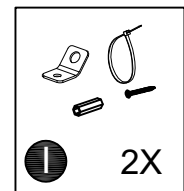

STEP 28

Finally, you got an Electric Fireplace with mantel

