

# Assembly Instructions

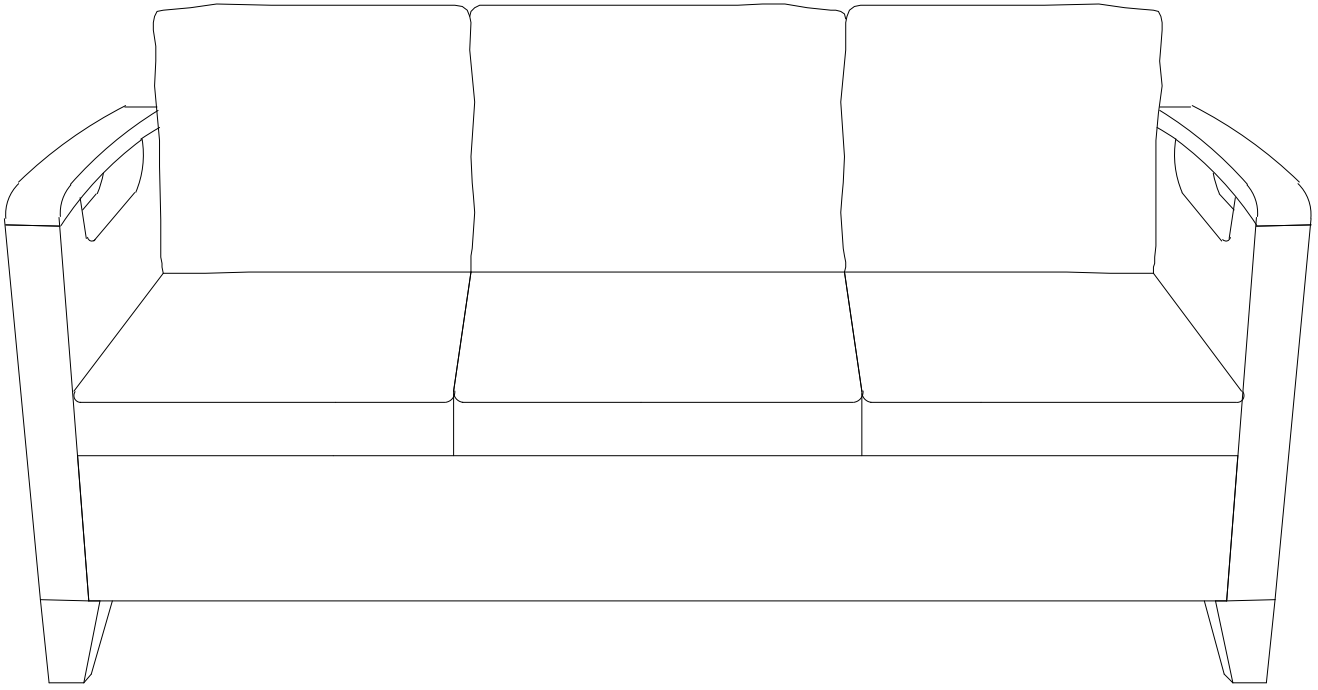









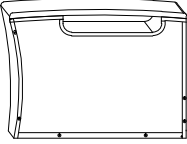

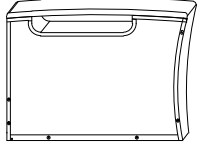

For any missing hardware, damaged parts and other problems.

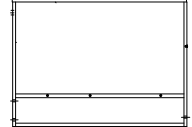
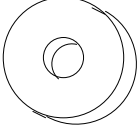
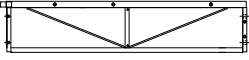
**\*Don't fully tighten all the bolts till the very end!**

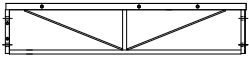
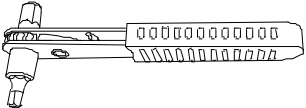
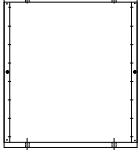
## PRE-ASSEMBLY PREPARATION:

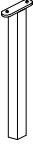
- Please read through the instructions before beginning assembly.
- Clear out the space for assembly and lay out all of the parts based on the Parts List, extra room will allow you to easily determine if all the pieces are present.
- Keep small parts and pieces away from children until fully assembled.

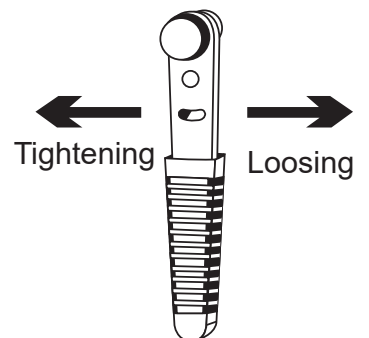
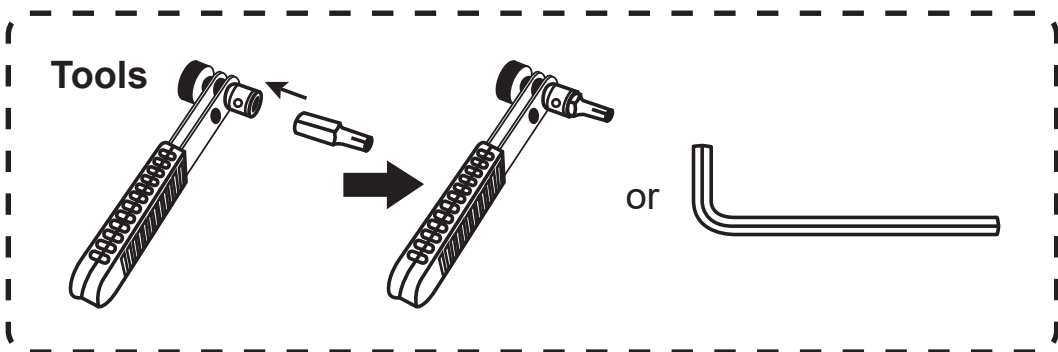

Part no.	Part	QTY	Image	Part no.	Part	QTY	Image
A1	Left arm	1		8	Bolt (M6*40mm)	12	
A2	Right arm	1		=	Bolt (M6*95mm)	2	
B1	Left back panel	1		@	Bolt (M6*15mm)	4	
B2	Right back panel	1		J	Washer M6	28	
C1	Left front panel	1		K	Allen wrench	1	
#	Right front panel	1		L	Ratchet wrench	1	
)	Seat panel	3		M	Seat cushion	3	
-	Middle foot	2		N	Back cushion	3	
7	Bolt (M6*35mm)	10					



**NOTE:** Tool L is spare wrench. If tool K can't work well, please try tool L.

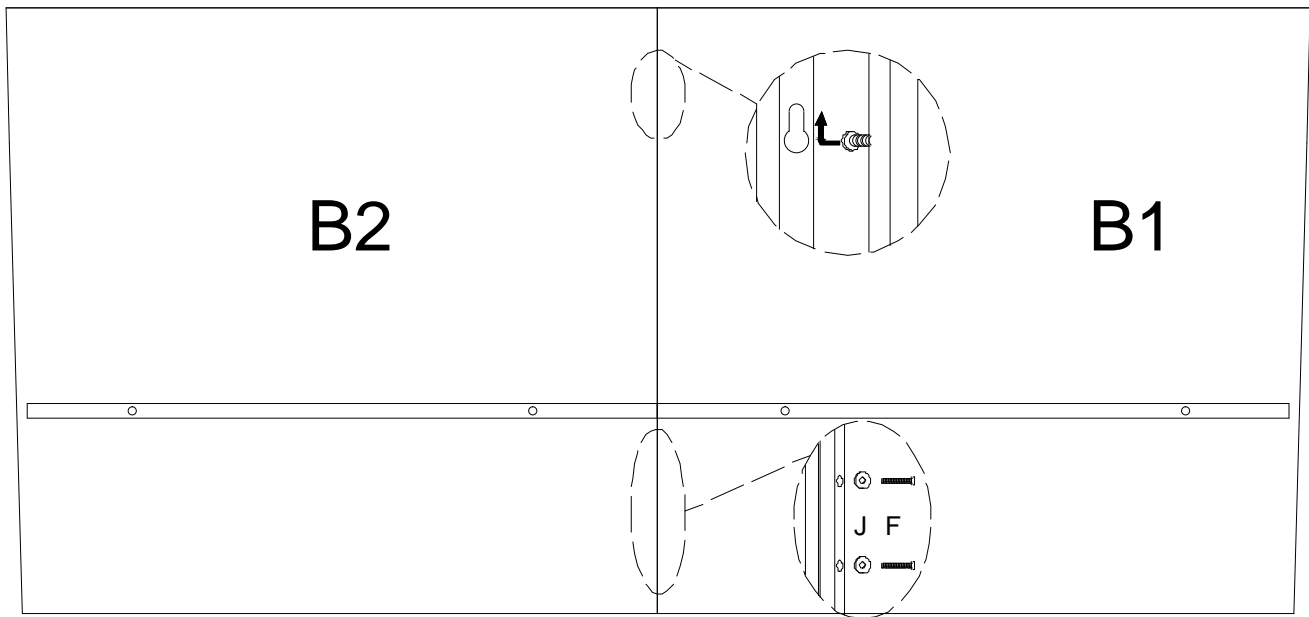

**Step 1:** Attach back B1&B2 with 2pcs bolts F and 2pcs washers J, using Allen wrench K. Note: Don't fully tighten the bolts.



F		M6*35	2
J		Ø16*Ø6.5*1	2

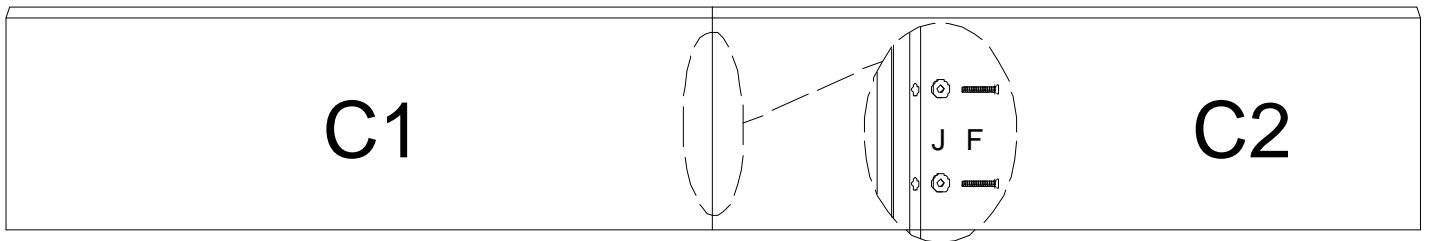

**Step 2:** Attach front panel C1&C2 with 2pcs bolts F and 2pcs washers J, using Allen wrench K. Note: Don't fully tighten the bolts.



F		M6*35	2
J		Ø16*Ø6.5*1	2

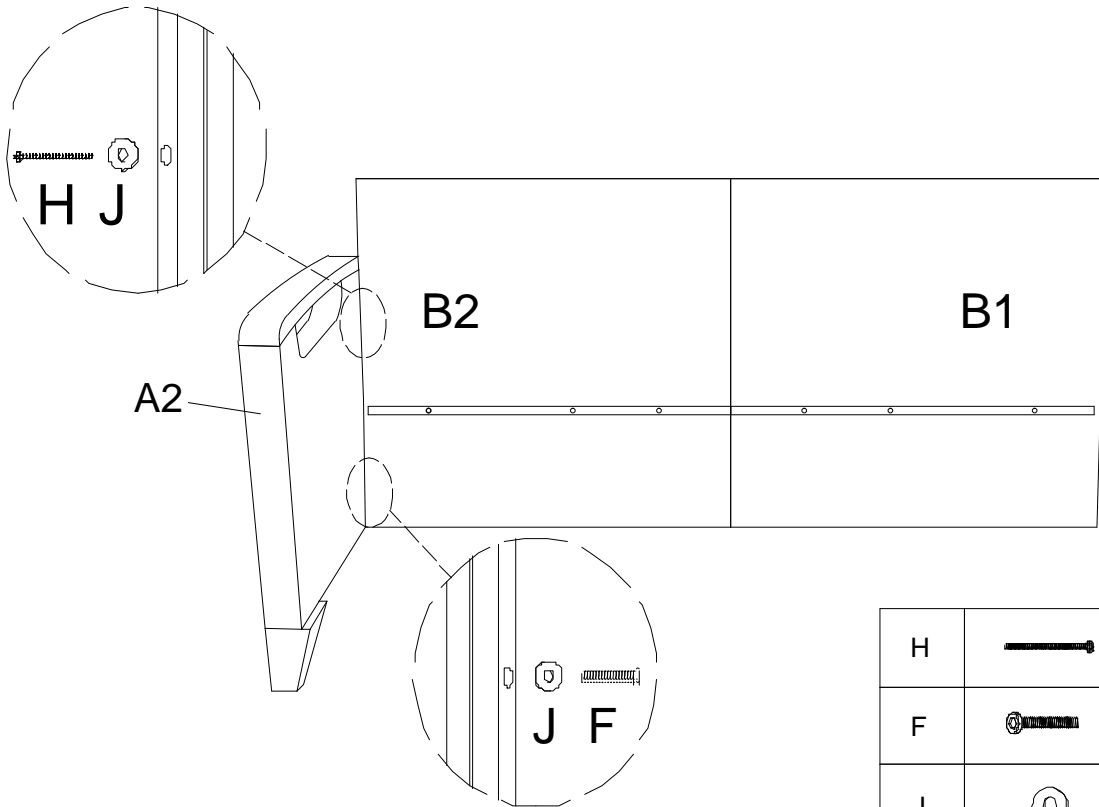

**Step 3:** Attach A2 to B2 with 1pc bolt H, 1pc bolt F and 2pcs washers J, using Allen wrench K. Note: Don't fully tighten the bolts.



H		M6*95	1
F		M6*35	1
J		Ø16*Ø6.5*1	2

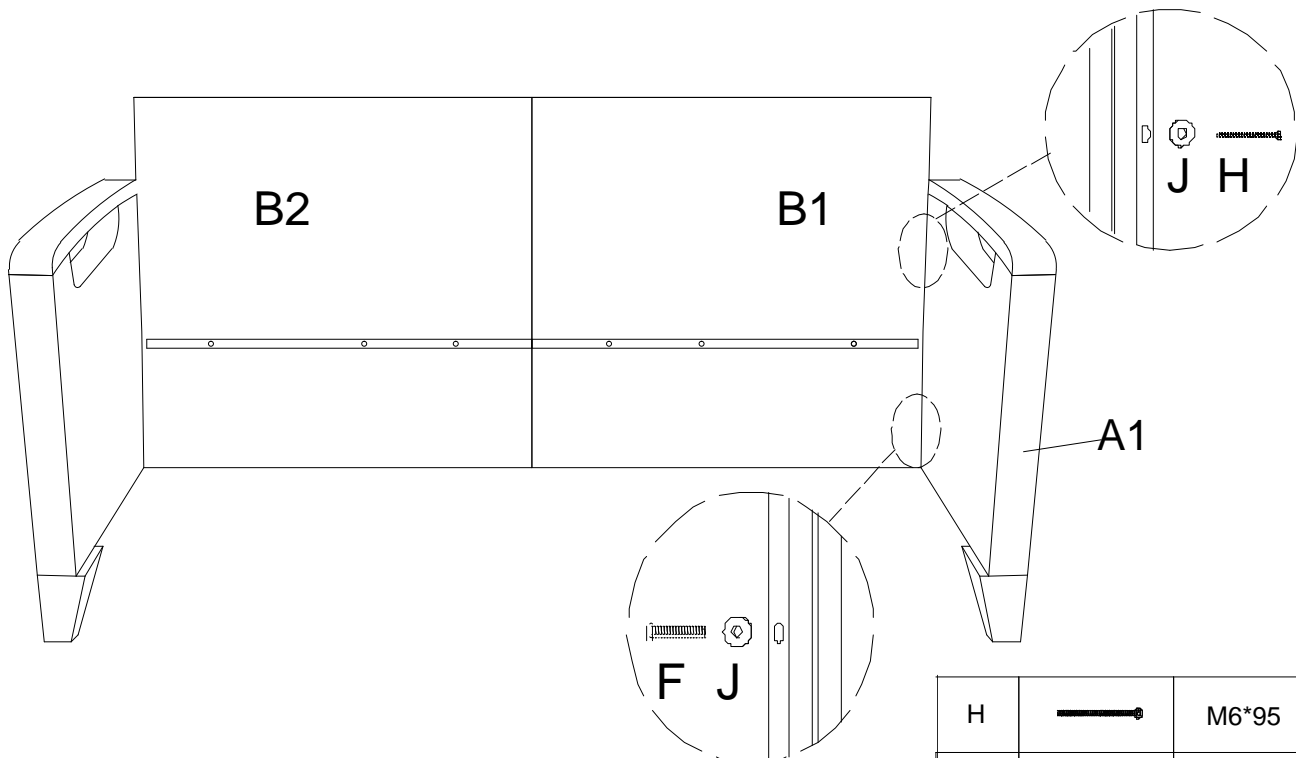

**Step 4:** Attach A1 to B1 with 1pc bolt H, 1pc bolt F and 2pcs washers J, using Allen wrench K. Note: Don't fully tighten the bolts.



H		M6*95	1
F		M6*35	1
J		Ø16*Ø6.5*1	2

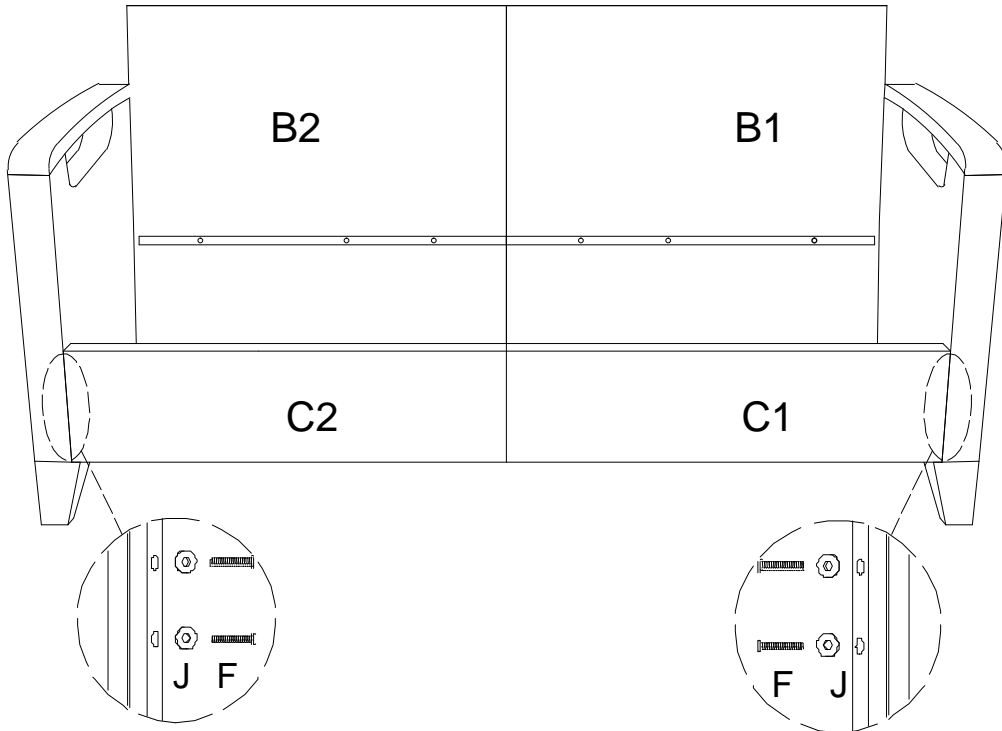

**Step 5:** Attach front panels C1&C2 to arms with 4pcs bolts F and 4pcs washers J, using Allen wrench K. Note: Don't fully tighten the bolts.



F		M6*35	4
J		Ø16*Ø6.5*1	4

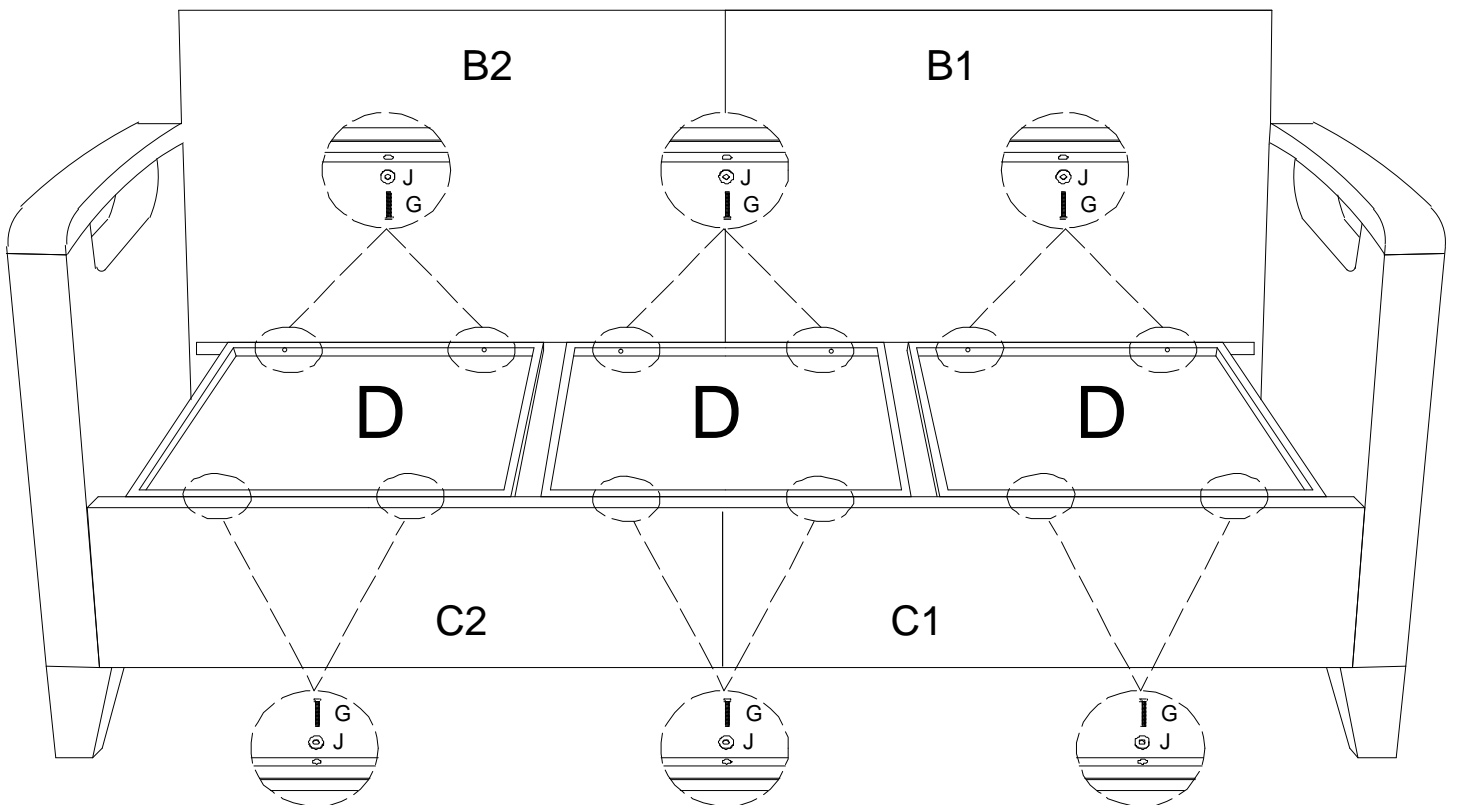

**Step 6:** Attach seat panels D to back panels and front panels with 12pcs bolts G and 12pcs washers J, using Allen wrench K. Note: Don't fully tighten the bolts.

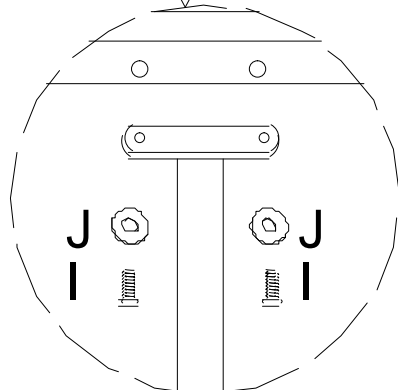
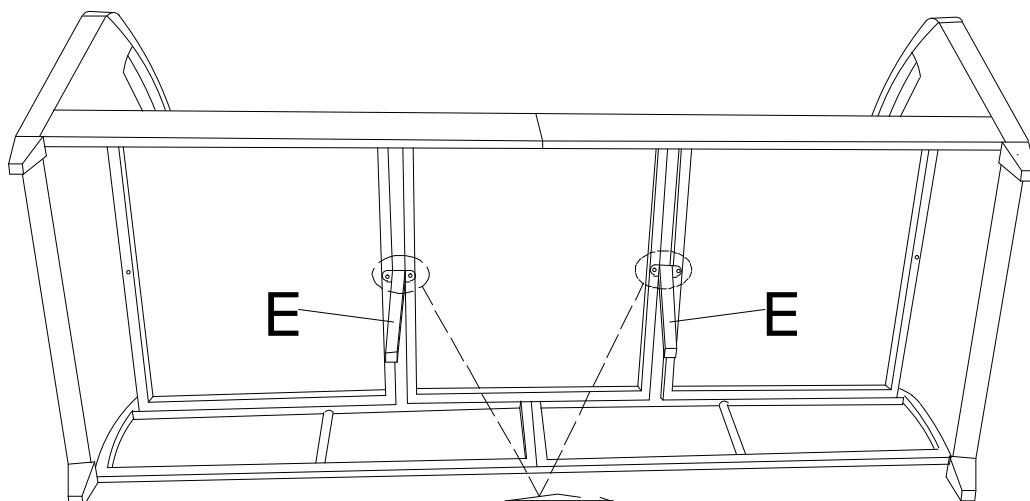

G		M6*40	12
J		Ø16*Ø6.5*1	12

**Step 7:** Attach middle 2pcs feet E to seat panels with 4pcs bolts I and 4pcs washers J, using Allen wrench K. Note: Please fully tighten all the bolts.



I		M6*15	4
J		Ø16*Ø6.5*1	4

**Step 8:** Put seat cushions M and back cushions N onto the seat. Assembly is now complete and the product is ready for use.

