

## Professional installation suggested for the wall mounting

Assemblage professionnel suggéré pour la fixation au mur

Ensamblaje profesional sugerido para la fijación al muro

### IMPORTANT: BEFORE BEGINNING THE ASSEMBLY

Make sure to validate the following information:

1. Wall anchor screws are not included. You must contact a professional to determine which screws are required for the studs in your wall.
2. Maximum weight supported: 1000 lbs distributed
3. Maximum mattress thickness: 12"
4. Bed will not stay down without the weight of the mattress. (Minimum weight of the mattress : 70 lbs)
5. Bed installs on carpet may not open or close properly. Level using the PA-844 (leg levelers) until the bed opens and closes properly.
6. Minimum height of ceiling needed with crown moldings: 93"  
Minimum height of ceiling needed without crown molding: 91"

### IMPORTANT : AVANT DE DÉBUTER L'ASSEMBLAGE

Assurez-vous de valider les informations suivantes :

1. Les vis d'ancrage au mur ne sont pas incluses. Consultez un professionnel pour sélectionner les vis appropriées aux montants dans votre mur.
2. Poids maximum supporté : 1000 lbs distribués
3. Épaisseur maximale de matelas : 12"
4. Le lit ne restera pas abaissé sans le poids du matelas. (Minimum de poids du matelas : 70 lbs)
5. Lorsque installé sur un tapis, le lit peut ne pas ouvrir ou fermer correctement. Nivelier en utilisant les PA-844 (pattes ajustables) jusqu'à ce que le lit ouvre et ferme correctement.
6. Hauteur minimale de plafond nécessaire pour l'installation du lit avec moulures de tête : 93"  
Hauteur minimale de plafond nécessaire pour l'installation du lit sans moulure de tête : 91"

### IMPORTANTE : ANTES DE EMPEZAR EL ENSAMBLAJE

Asegúrese de validar las informaciones siguientes :

1. Los tornillos de anclaje a la pared no son incluidos. Consulte a un profesional para seleccionar los tornillos adaptados a los importes en su pared.
2. Peso máximo sostenido : 1000 lbs distribuidos
3. Espesor máximo de colchón : 12"
4. La cama no quedará abbaissé sin el peso del colchón. (Peso mínimo del colchón : 70 libras)
5. Cuando instalada sobre una alfombra, la cama puede no abrir o cerrarse correctamente. Nivelar utilizando PA-844 (patas ajustables) hasta que la cama abra y se cierre correctamente.
6. Altura mínima de techo necesario para la instalación de la cama con molduras de cabeza : 93 "  
Altura mínima de techo necesario para la instalación de la cama sin moldura de cabez : 91 "

**Thank you for choosing our product.  
Your total satisfaction is our #1 priority.**

**Customer Service and warranty information**

Should you have a problem or need more information concerning the warranty, **do not call to the place of purchase.**  
**Please call our customer service department for immediate assistance using the following toll free number.**

Please have your assembly instruction manual on hand when you call. Our products are warranted to the original purchaser against defects in material or workmanship in the furniture. Defects as mentioned in this warranty refer to any imperfections which may impair the use of the product. Our warranty is expressly limited to the replacement of furniture parts and components for ten years following the date of purchase. We will replace any part that is defective. This warranty applies under conditions of normal use. Our furniture products are not intended for outdoor use. The warranty does not cover defects caused by improper assembly or disassembly, defects occurring after purchase due to product modifications, intentional damage, accident, misuse, exposure to the elements and labor or assembly costs. We reserve the right to request proof of purchase to document a warranty claim. In no event shall we be liable for incidental or consequent damages resulting from the misuse of the product. This warranty is not transferable and is valid only in Canada and the United States excluding Alaska, Hawaii and Puerto Rico.

**MERCI D'AVOIR CHOISI LES PRODUITS.  
VOUS SATISFAIRE EST NOTRE PRIORITÉ.**

***Gracias por elegir un producto.  
Su entera satisfacción es nuestra prioridad N°1.***

► PARTS / PIÈCES / PIEZAS

| CODE / CÓDIGO | QTY / QTÉ / CANT. | CODE / CÓDIGO | QTY / QTÉ / CANT. | CODE / CÓDIGO | QTY / QTÉ / CANT. | CODE / CÓDIGO | QTY / QTÉ / CANT. |
|---------------|-------------------|---------------|-------------------|---------------|-------------------|---------------|-------------------|
| 30            | 1                 | 61            | 1                 | 87            | 1                 | 573 mm        | 1                 |
| 31            | 1                 | 70            | 2                 | 532 mm        | 6                 | 1764 mm       | 1                 |
| 40            | 1                 | 81            | 1                 | 1596 mm       | 2                 | 1451 mm       | 6                 |
| 41            | 1                 | 83            | 1                 | 570 mm        | 2                 | 1646 mm       | 1                 |
| 60            | 3                 | 85            | 1                 | 573 mm        | 1                 |               |                   |

► PROBLEMS OR INFORMATION



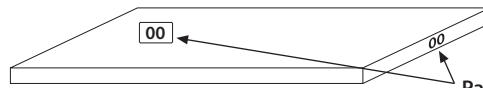
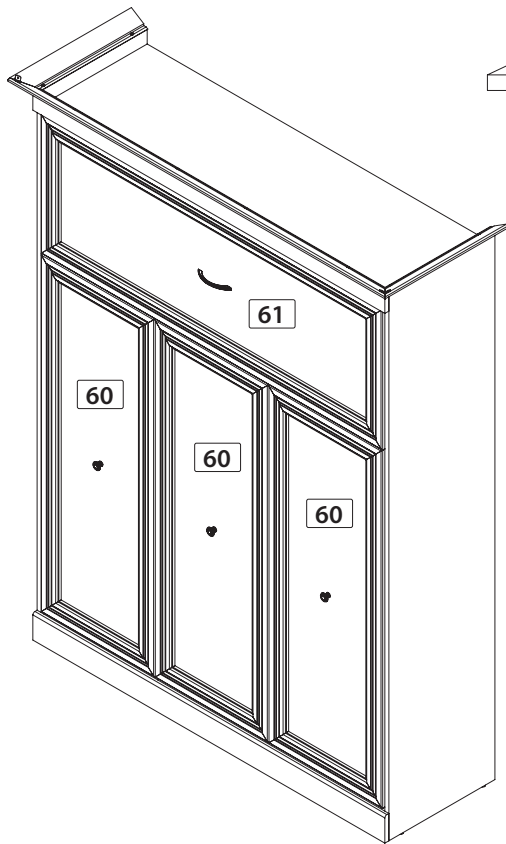



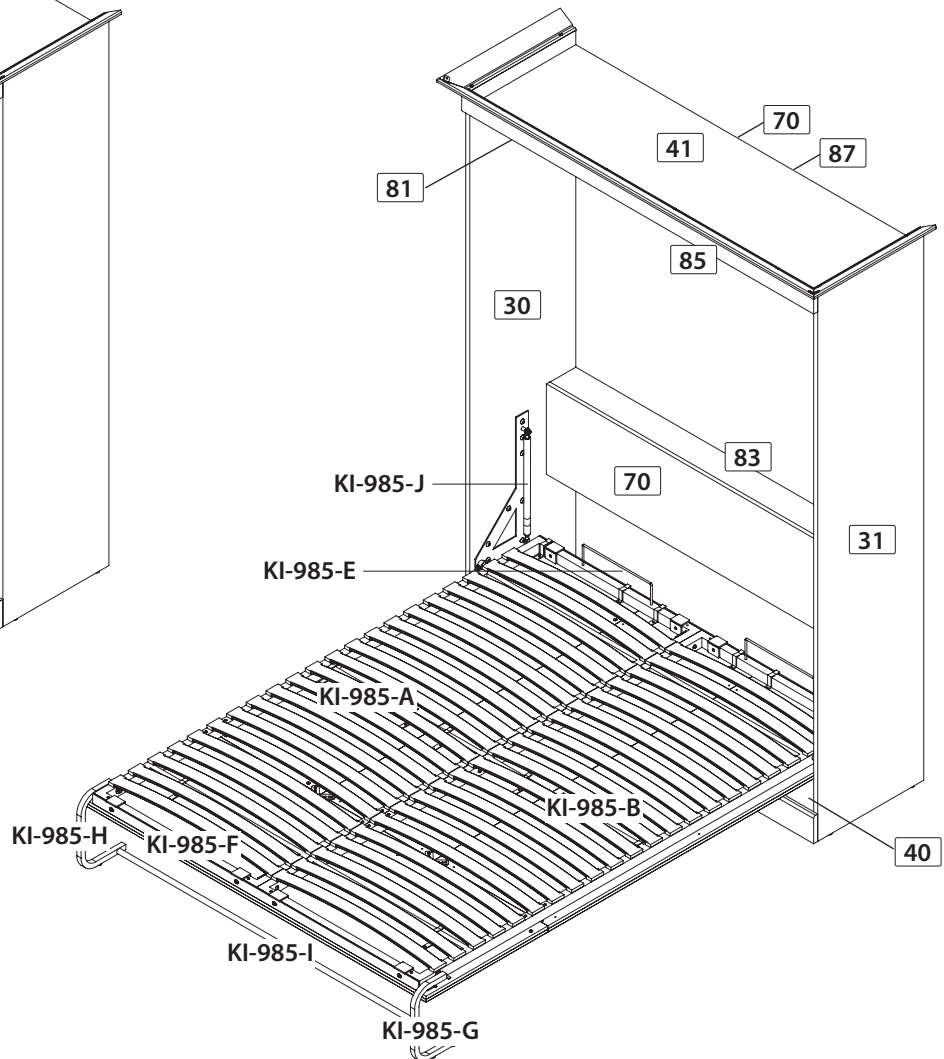



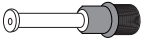

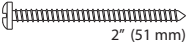
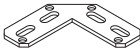

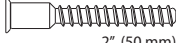
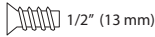
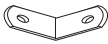
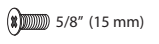

POUR TOUT PROBLÈME OU INFORMATION  
PROBLEMAS O INFORMACIÓN

















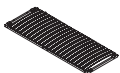

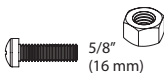

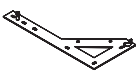
Part number on the top or on edge  
Numéro de pièce sur le dessus ou sur le chant  
Número de referencia en la parte superior o en el borde





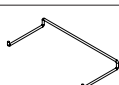
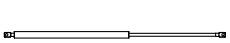

**HARDWARES IN BOX 1 / QUINCAILLERIES DANS LA BOÎTE 1 / QUINCALLAS EN CAJA 1**

| CODE / CÓDIGO  | QTY / QTÉ / CANT. | CODE / CÓDIGO   | QTY / QTÉ / CANT.  | CODE / CÓDIGO   | QTY / QTÉ / CANT.  | CODE / CÓDIGO   | QTY / QTÉ / CANT.  |
|--|-------------------|---|--------------------|---|--|---|--|
| CA-100  | 16                | H-36     | 8                  | RO-994  | 4<br>Outside diameter<br>Diamètre extérieur<br>Diámetro exterior<br>3/4" (19 mm) | VR-215                 | 12<br>2" (51 mm)   |
| EQ-143  | 2                 | KI-932H  | 16<br>3/4" (18 mm) | VC-204  | 16<br>2" (50 mm)   | 3500-400350            | 36<br>1/2" (13 mm)   |
| EQ-943  | 2                 | KI-932I  | 16<br>5/8" (15 mm) | VF-229  | 5<br>1/2" (13 mm)  | <b>LEG WARNING STICKER</b><br>ÉTIQUETTE AVERTISSEMENT DE LA PATTE<br>ETIQUETA DE ADVERTENCIA DE LA PIERNA | 1  |
| EQ-980  | 3                 | PA-844   | 4<br>1" (25 mm)    | VG-206  | 50<br>1" (25 mm)   | RO-593                 | 3<br>Outside diameter<br>Diamètre extérieur<br>Diámetro exterior<br>1 1/4" (32 mm) |
| GO-796  | 21                | PO-777   | 3                  | VR-207  | 4<br>1/2" (13 mm)  |   |  |
| H-03    | 8                 | PO-912   | 1                  | VR-213  | 5<br>1 1/4" (32 mm)  |   |  |

**HARDWARES IN BOX 3 / QUINCAILLERIES DANS LA BOÎTE 3 / QUINCALLAS EN CAJA 3**

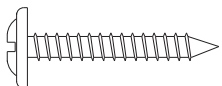
| CODE / CÓDIGO  | QTY / QTÉ / CANT. | CODE / CÓDIGO  | QTY / QTÉ / CANT. | CODE / CÓDIGO   | QTY / QTÉ / CANT.     | CODE / CÓDIGO  | QTY / QTÉ / CANT. |
|--|-------------------|--|-------------------|---|-----------------------|--|-------------------|
| KI-985-A    | 1                 | KI-985-F    | 2                 | KI-985-K    | 14                    | KI-985-P    | 2                 |
| KI-985-B   | 1                 | KI-985-G   | 1                 | KI-985-L   | 4<br>5/8"<br>(16 mm)  | KI-985-Q   | 1                 |
| KI-985-C  | 1                 | KI-985-H  | 1                 | KI-985-M  | 12<br>5/8"<br>(16 mm) | KI-985-R  | 4                 |
| KI-985-D  | 1                 | KI-985-I  | 1                 | KI-985-N  | 8<br>1 3/4" (44 mm)   | KI-985-S  | 8                 |
| KI-985-E  | 2                 | KI-985-J  | 2                 | KI-985-O  | 3<br>2 3/4" (70 mm)   |  |                   |

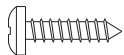
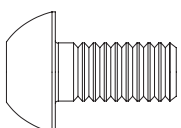
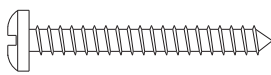
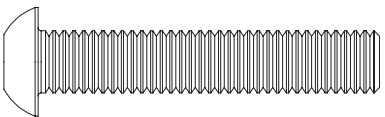
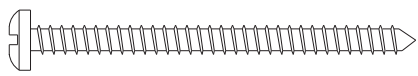
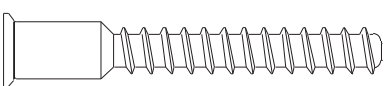
REAL SIZE / GRANDEUR RÉELLE / TAMAÑO REAL

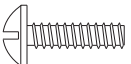
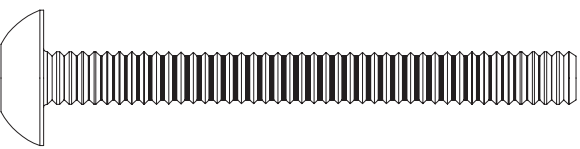
| CODE / CÓDIGO   | QTY / QTÉ / CANT. | CODE / CÓDIGO   | QTY / QTÉ / CANT. |
|---|-------------------|---|-------------------|
| KI-932I  5/8" (16 mm)      | 16                | VG-206  1" (25 mm)        | 50                |
| KI-985-L  5/8" (16 mm)     | 4                 | VR-207  1/2" (13 mm)      | 4                 |
| KI-985-M  5/8" (16 mm)     | 12                | VR-213  1 1/4" (32 mm)    | 5                 |
| KI-985-N  1 3/4" (44 mm)   | 8                 | VR-215  2" (51 mm)        | 12                |
| VC-204  2" (50 mm)        | 16                | 3500-400350  1/2" (13 mm) | 36                |
| VF-229  1/2" (13 mm)     | 5                 |   |                   |
| KI-985-O  2 3/4" (70 mm) |                   |   | 3                 |

**Professional installation suggested**

Assemblage professionnel suggéré

Ensamblaje profesional sugerido

**IMPORTANT: BEFORE BEGINNING THE ASSEMBLY**

Make sure to validate the following information:

1. Wall anchor screws are not included. You must contact a professional to determine which screws are required for the studs in your wall. Please refer to step 5.
2. Maximum weight supported: 1000 lbs distributed
3. Maximum mattress thickness: 12"
4. Bed will not stay down without the weight of the mattress.
5. Bed install on carpet may not open or close properly. Level using the PA-844 (leg levelers) until the bed opens and closes properly.
6. Minimum height of ceiling needed with crown molding: 93"  
Minimum height of ceiling needed without crown molding: 91"

**IMPORTANT : AVANT DE DÉBUTER L'ASSEMBLAGE**

Assurez-vous de valider les informations suivantes :

1. Les vis d'ancrage au mur ne sont pas incluses. Consultez un professionnel pour sélectionner les vis appropriées aux montants dans votre mur. Référez-vous à l'étape 5.
2. Poids maximum supporté : 1000 lbs distribués
3. Épaisseur maximale de matelas : 12"
4. Le lit ne restera pas abaissé sans le poids du matelas.
5. Lorsque installé sur un tapis, le lit peut ne pas ouvrir ou fermer correctement. Nivelez en utilisant les PA-844 (pattes ajustables) jusqu'à ce que le lit ouvre et ferme correctement.
6. Hauteur minimale de plafond nécessaire pour l'installation du lit avec moulures de tête : 93"  
Hauteur minimale de plafond nécessaire pour l'installation du lit sans moulure de tête : 91"

**IMPORTANTE : ANTES DE EMPEZAR EL ENSAMBLAJE**

Asegúrese de validar las informaciones siguientes :

1. Los tornillos de anclaje al pared no son incluidos. Consulte a un profesional para seleccionar los tornillos adaptados a los muros en su pared. Refiérase a la etapa 5.
2. Peso máximo soportado: 1000 lbs distribuidos
3. Espesor máximo de colchón: 12"
4. La cama no quedará abajada sin el peso del colchón.
5. Cuando instalado sobre una alfombra, la cama puede no abrir o cerrarse correctamente. Nivelar utilizando PA-844 (patas ajustables) hasta que la cama abra y se cierre correctamente.
6. Altura mínima de techo necesario para la instalación de la cama con moldura de cabeza: 93"  
Altura mínima de techo necesario para la instalación de la cama sin moldura de cabeza: 91"

**For future reference and to better serve you, please complete and apply the self-adhesive sticker in an accessible space such as the back side of part 61.**

Pour mieux vous servir en cas de besoin, veuillez compléter et apposer l'autocollant dans un endroit facilement accessible tel que sur l'endos de la pièce 61.

Para futura referencia y mejor servicio por favor pegue la etiqueta en un lugar accesible, por ejemplo el fondo de la pieza 61.

**IMPORTANT NOTICE / NOTE IMPORTANTE / NOTA IMPORTANTE**

**Main hardware system. Installation steps / Système de quincaillerie principal. Étapes d'installation.**  
*Sistema principal de quincalla. Etapas de instalación.*

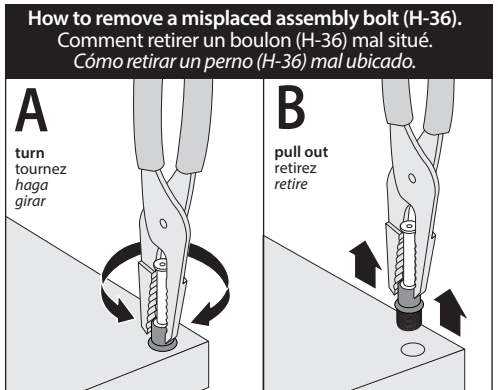
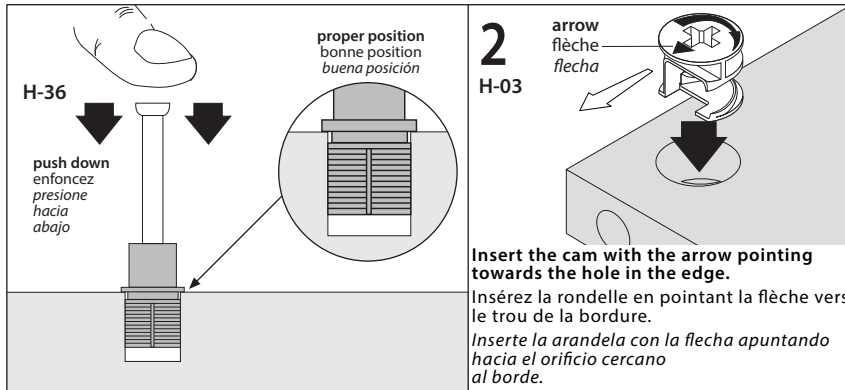

**Main hardware system. Assembly steps / Système de quincaillerie principal. Étapes d'assemblage.**  
*Sistema principal de quincalla. Etapas de ensamblaje.*

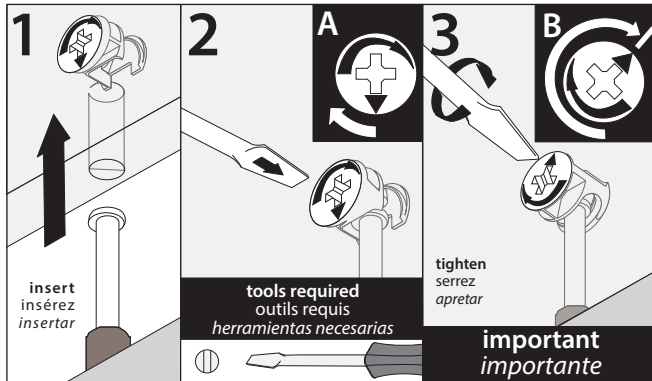

**Make sure to properly tighten each cam to ensure furniture solidity. Otherwise, parts could be damaged or the user could be injured.**

Assurez-vous de bien resserrer chaque rondelle pour assurer la solidité du meuble. Dans le cas contraire, des pièces pourraient être endommagées ou l'utilisateur pourrait se blesser.

Asegúrese de apretar bien cada arandela para garantizar la solidez del mueble. De lo contrario, podría provocarse daño a las piezas o las personas.

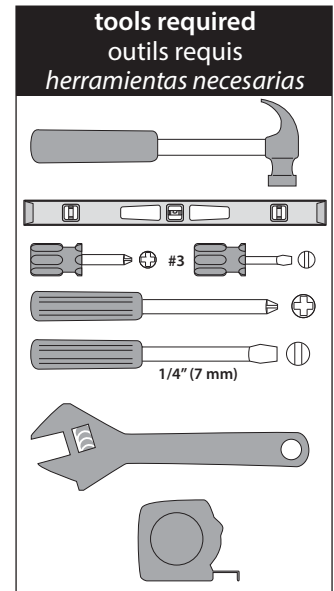

**Assembling sequence**  
 Séquence d'assemblage  
 Secuencia de ensamblaje  
**Parts / Pièces / Piezas:**

41 + EQ-980 + 87

### IMPORTANT / IMPORTANTE

Place boxes under parts during the assemblies to avoid damages.

Placer les boîtes sous les pièces lors des assemblages pour éviter les bris.

Colocar las cajas bajo las piezas en el momento de los ensamblajes para evitar los quebrantos.

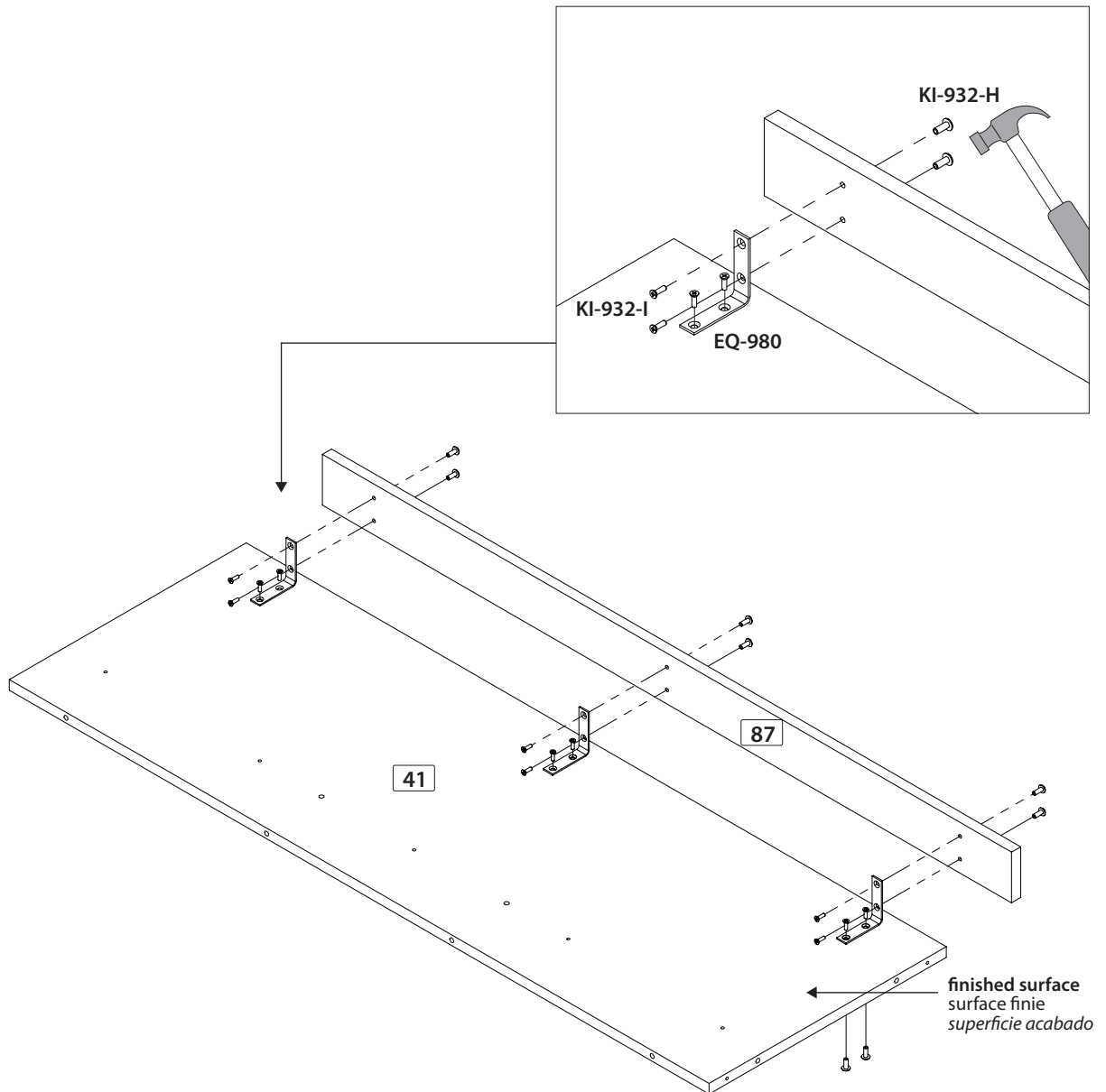

EQ-980

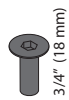

KI-932H  
3/4" (18 mm)



KI-932I  
5/8" (15 mm)

Code / Código

Qty / Qté / Cant.

x 3

x 12

x 12

**Assembling sequence**  
 Séquence d'assemblage  
 Secuencia de ensamblaje  
**Parts / Pièces / Piezas:**



**30** + KI-985-D + KI-985-M

**31** + KI-985-C + KI-985-M

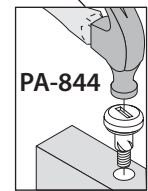
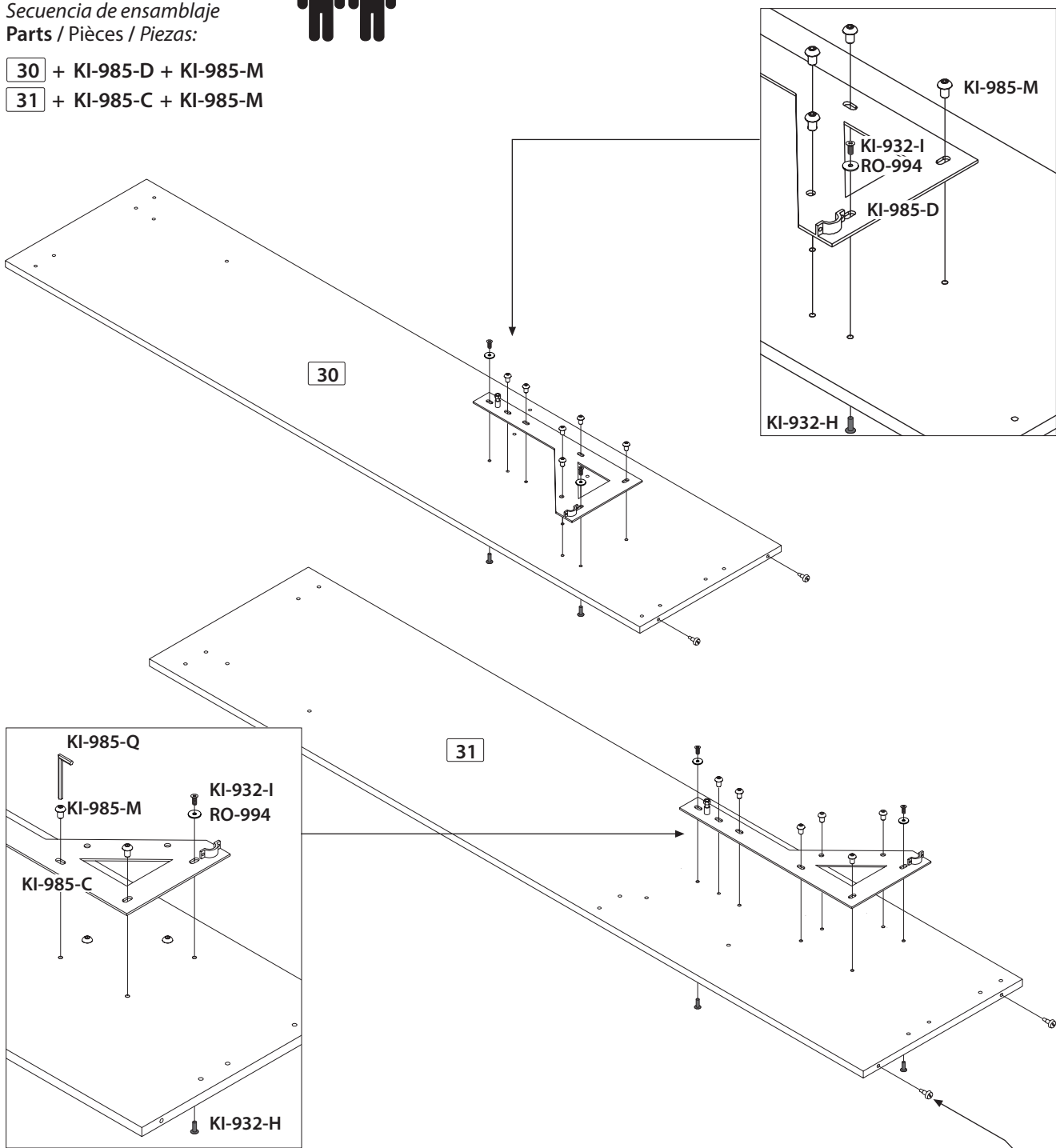

Code / Código

KI-985-C

KI-985-D

KI-985-M

KI-985-Q

PA-844

RO-994

KI-932I

KI-932H

Qty / Qté / Cant.

x 1

x 1

x 12

x 1

x 4

x 4

x 4

x 4

**Assembling sequence**  
 Séquence d'assemblage  
 Secuencia de ensamble  
 Parts / Pièces / Piezas:



70 83 30 31 41 40

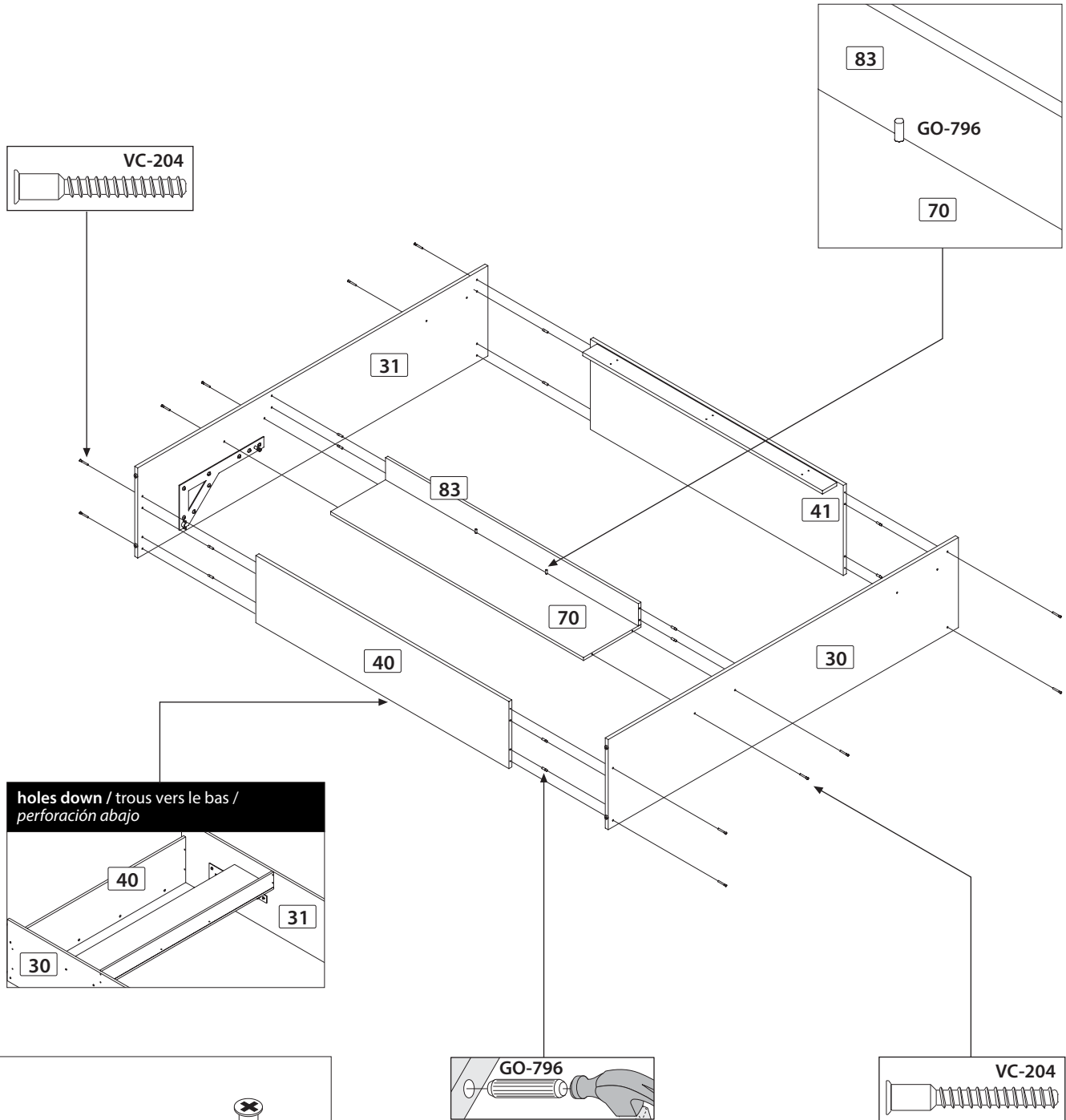

Code / Código

GO-796

VC-204

Qty / Qté / Cant.

x 14

x 12

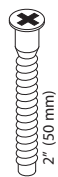

2" (50 mm)



You can be seriously injured if you don't follow these instructions

Vous risquez d'être gravement blessé si vous ne suivez pas ces instructions

Usted corre peligro de ser herido gravemente si usted no sigue estas instrucciones

## IMPORTANT: CONTACT A PROFESSIONAL

THE UNIT HAS TO LEAN ON ALL ITS LENGTH ON THE WALL OF THE ROOM.

Follow these steps:

1. Determine where your bed will be located.
2. Level the unit. To level your furniture, adjust leg PA-844 (installed previously in step 2)
3. Find the location of the studs in the wall by using a stud sensor, then identify the area (anchor zone) which will align with the stud.
4. Wall anchor screws are not included. You must contact a professional to determine which screws are required for the studs in your wall. Please refer to step 5.
5. Refer to the identified anchor zones to screw into the plywood board (part 87) to fix to the wall. Use the appropriate screws for your studs. **THE SCREWS MUST BE VERY WELL ANCHORED INTO STUDS.**

## IMPORTANT : CONSULTER UN PROFESSIONNEL

LE MEUBLE DOIT S'APPUYER SUR TOUTE SA LONGUEUR AU MUR DE LA PIÈCE.

Pour son installation, veuillez suivre les étapes suivantes :

1. Connaître l'emplacement final de votre lit vertical.
2. Nivelier. Pour nivelier le meuble, ajuster les pattes PA-844 (installées préalablement à l'étape 2)
3. Trouver l'emplacement des montants dans votre mur à l'aide d'un détecteur de montant, identifier ensuite la section (zone d'ancrage) qui s'alignera avec le montant.
4. Les vis d'ancrage au mur ne sont pas incluses. Consultez un professionnel pour sélectionner les vis appropriées aux montants dans votre mur. Référez-vous à l'étape 5.
5. Visser dans les zones d'ancrage identifiées à travers la bande de contre-plaqué (pièce 87) pour la fixation au mur. Utiliser des vis appropriées aux montants de votre mur. **LES VIS DOIVENT ÊTRE TRÈS BIEN ANCRÉES DANS LES MONTANTS.**

## IMPORTANTE: CONSULTAR A UN PROFESIONAL

EL MUEBLE DEBE APOYARSE EN TODA SU LONGITUD A LA MADURA DE LA PIEZA.

Siga las etapas siguientes para su instalación con la pared :

1. Situar la unidad en su emplazamiento final.
2. Nivelar. Para nivelar su mueble, ajustar la pata PA-844 (Instaladas previamente a la etapa 2)
3. Encontrar el emplazamiento de los importes en su pared con un detector de importes, identificar luego la sección (zona de anclaje) que se alineará con importe.
4. Los tornillos de anclaje a la pared no son incluidos. Consulte a un profesional para seleccionar los tornillos adaptados a los importes en su pared. Refiérase a la etapa 5.
5. Antornillar en las zonas de anclaje identificadas a través de la banda de contrachapado (pieza 87) para la fijación a la pared. Utilizar tornillos adaptados a los importes de su pared. **LOS TORNILLOS DEBEN SER MUY BIEN ANCLADOS IN LOS IMPORTES.**

### tools required outils requis herramientas necesarias

Stud sensor  
Détecteur  
de montant  
Detector de vigas

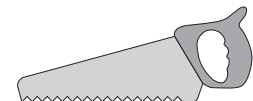
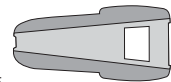

We are released from any responsibility if bed is not secured to the wall into wood or metal studs.

Nous se dégage de toutes responsabilités si le lit n'est pas fixé au mur dans les montants en bois ou en métal.

Nosotros se libran de toda responsabilidad si la cama no es fijada sobre la pared en importes de madera o en metal.

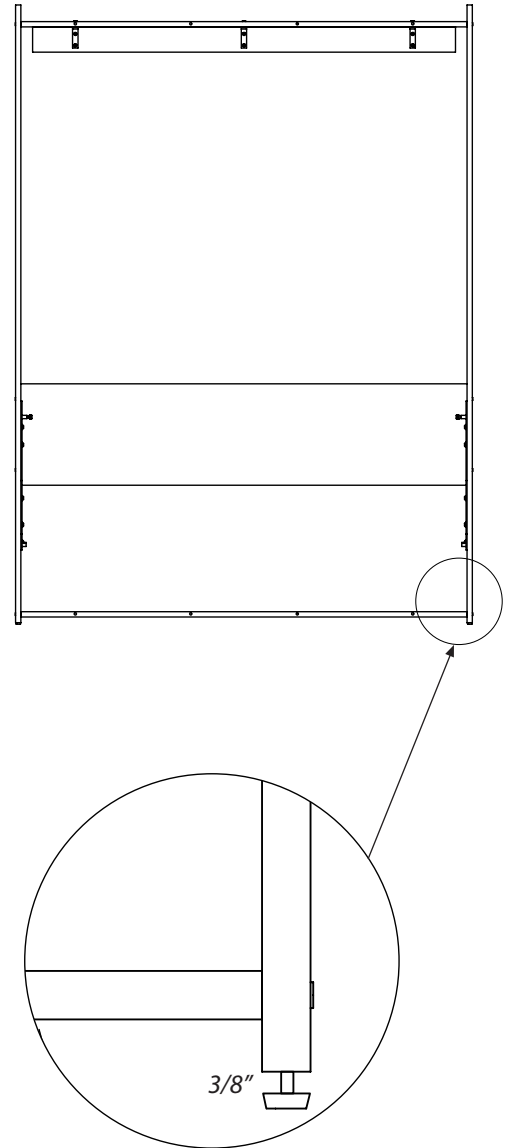
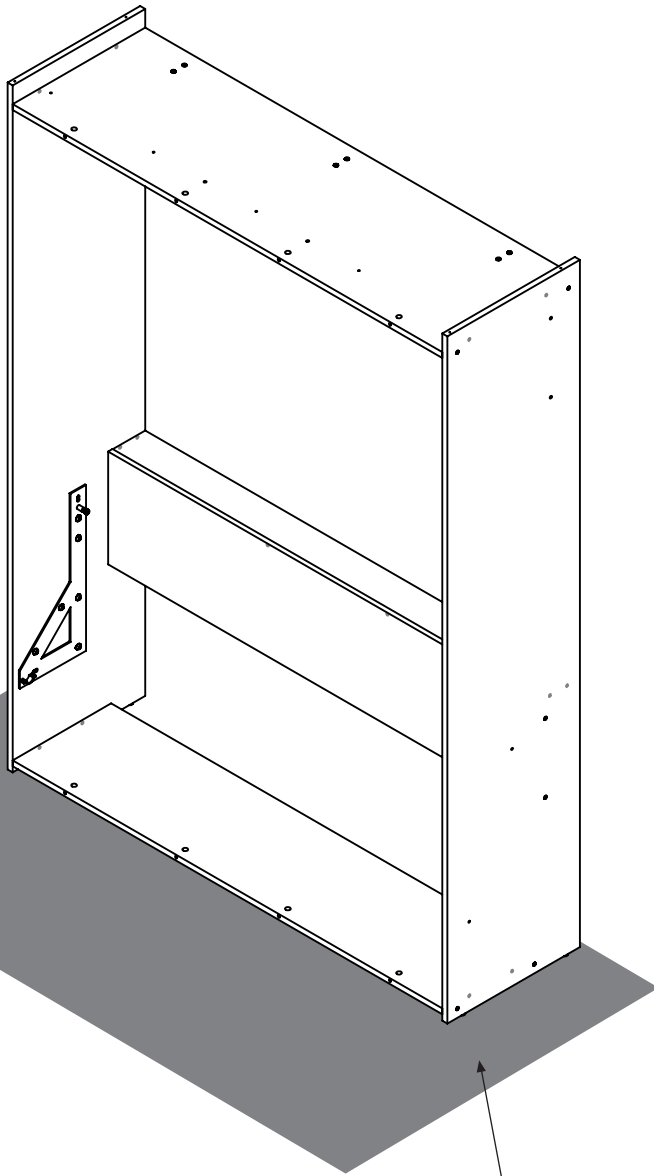

**If you have carpet, up the adjustment of PA-844 3/8 inches .**  
Si vous avez du tapis, monter l'ajustement des PA-844 de 3/8 pouces.  
*Si tiene alfombra , la adaptación de la PA- 844 3/8 pulgadas.*



### Important/Importante

The back should be completely against the wall.  
Le dos doit être complètement appuyé au mur.  
*La espalda debe estar completamente en contra de la pared.*

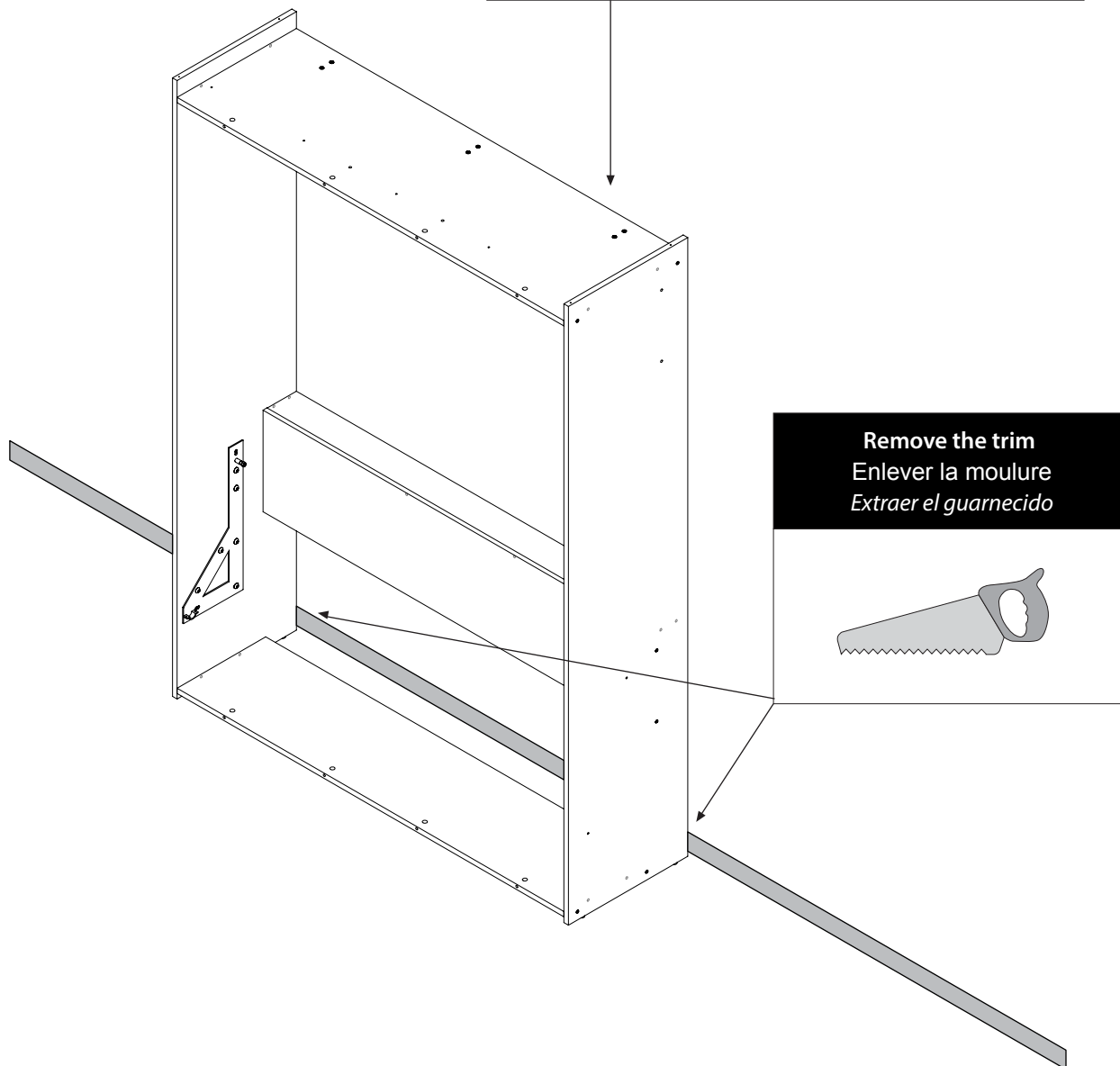

Remove the trim  
Enlever la moulure  
*Extraer el guarnecido*

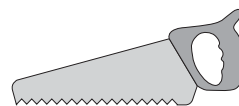



### Important/Importante

Level the cabinet all sides, with the PA-844.  
Niveler le meuble de tout les côtés, à l'aide des PA-844.  
Nivele el gabinete todos los lados, con el PA-844.

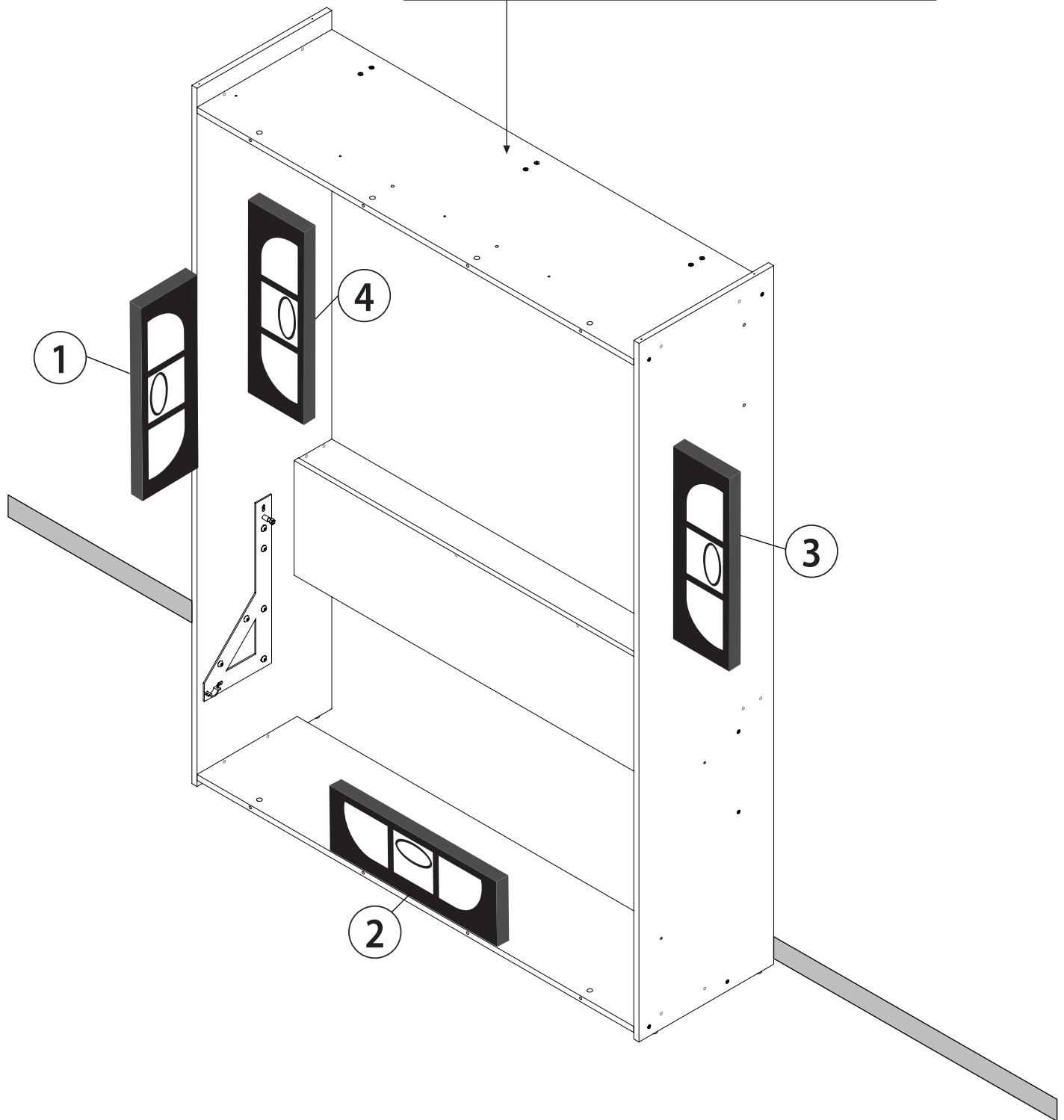



STUDS / MONTANTS / IMPORTES

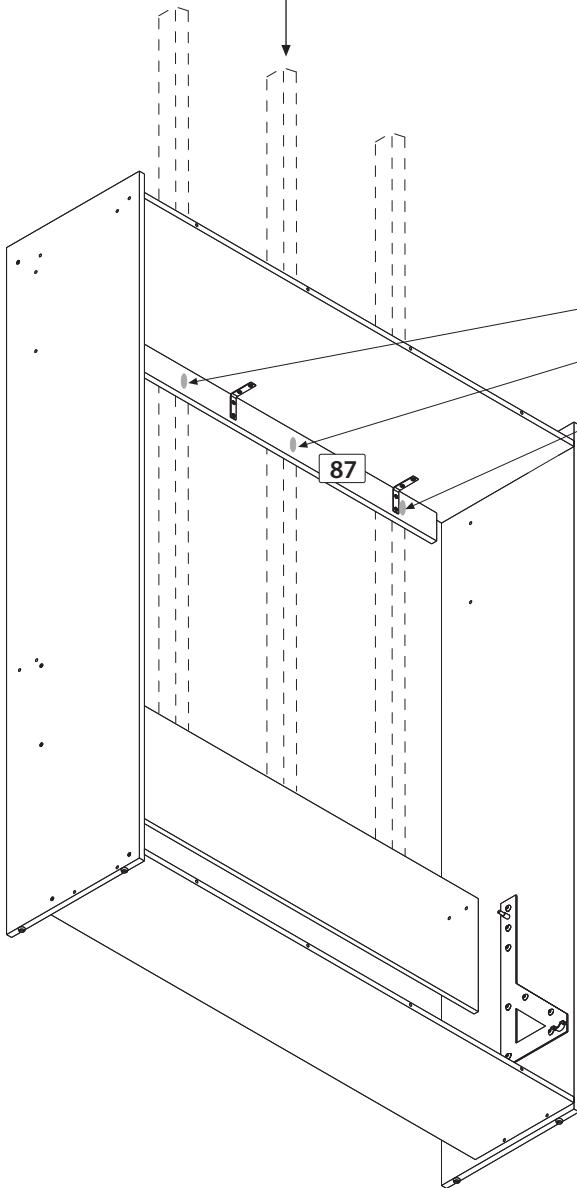

ANCHOR ZONES / ZONES D'ANCRAGE / ZONAS DE ANCLAJE

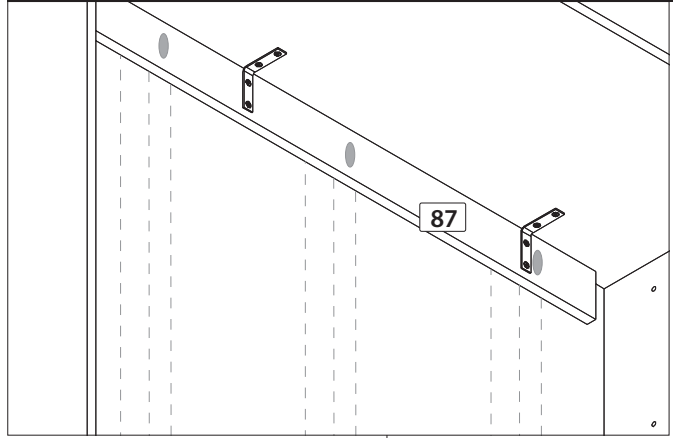

Assembling sequence  
Séquence d'assemblage  
Secuencia de ensamblaje  
Parts / Pièces / Piezas:



31 40 30 + 70

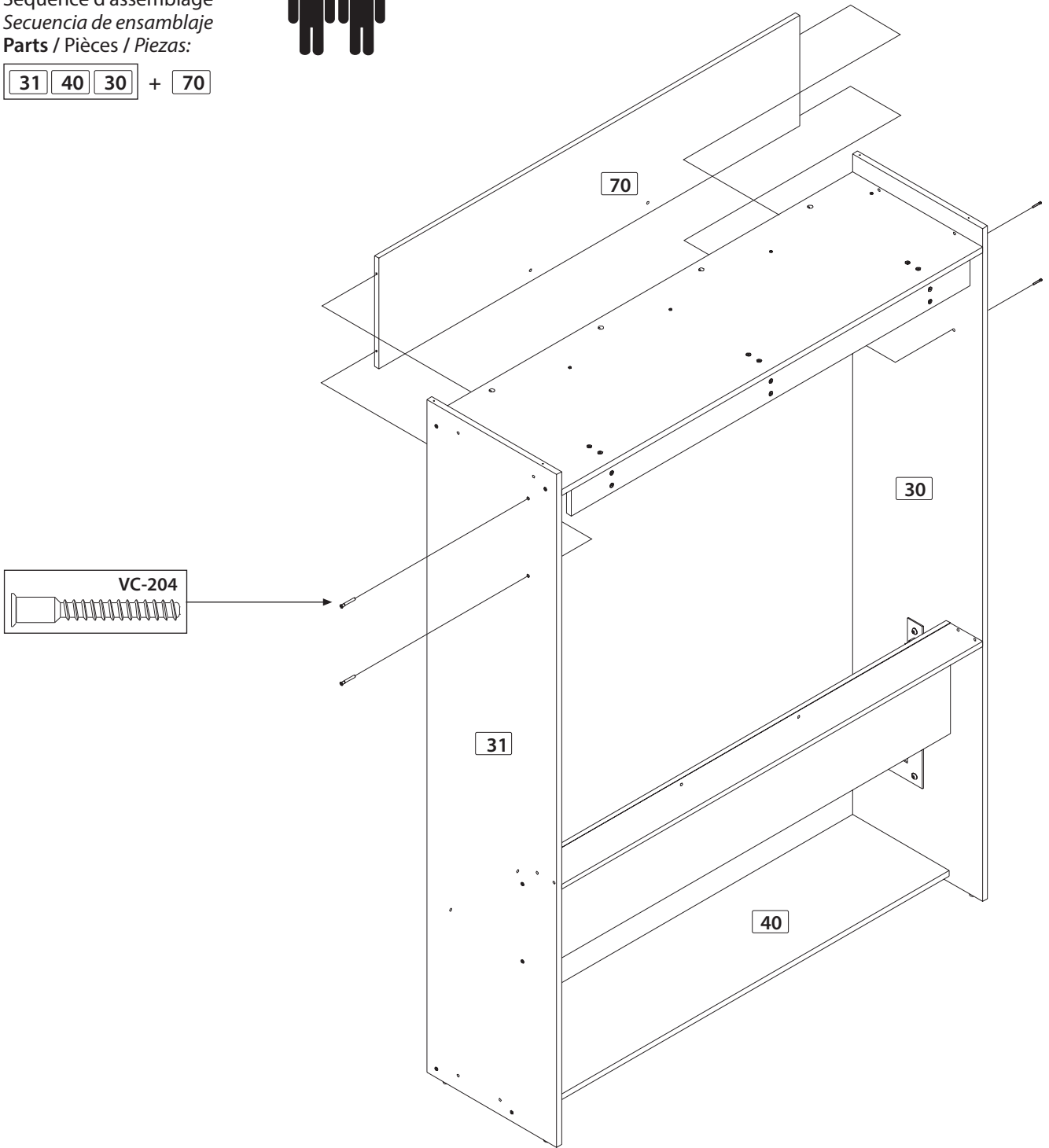

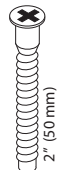
|                   |   |
|-------------------|---|
| 5                 |  |
| Code / Código     | VC-204  |
| Qty / Qté / Cant. | x 4   |

## Important/Importante

The washers placed in between the base are to adjust the width of the bed so the bearings are secured.

Les rondelles placées entre les deux structures du lit servent à ajuster la largeur du lit afin que le roulement à billes soit correctement positionné.

Las arandelas colocadas en entre la base son para ajustar la anchura de la cama de modo que los cojinetes están asegurados.

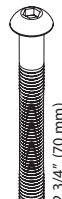
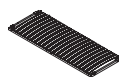
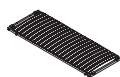
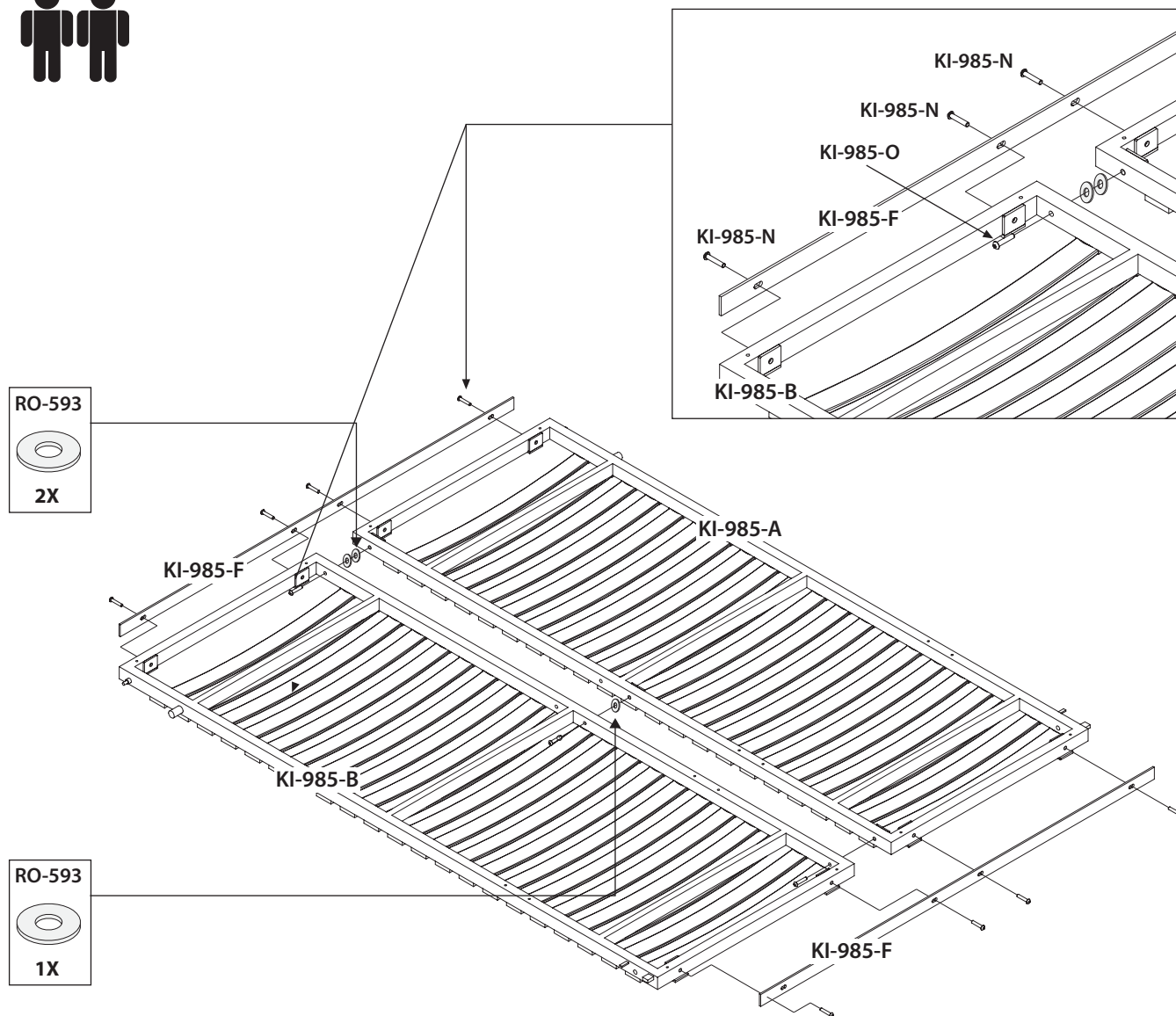

Code / Código

KI-985-A

KI-985-B

KI-985-F

KI-985-N

KI-985-O

RO-593

Qty / Qté / Cant.

x 1

x 1

x 2

x 8

x 3

x 3

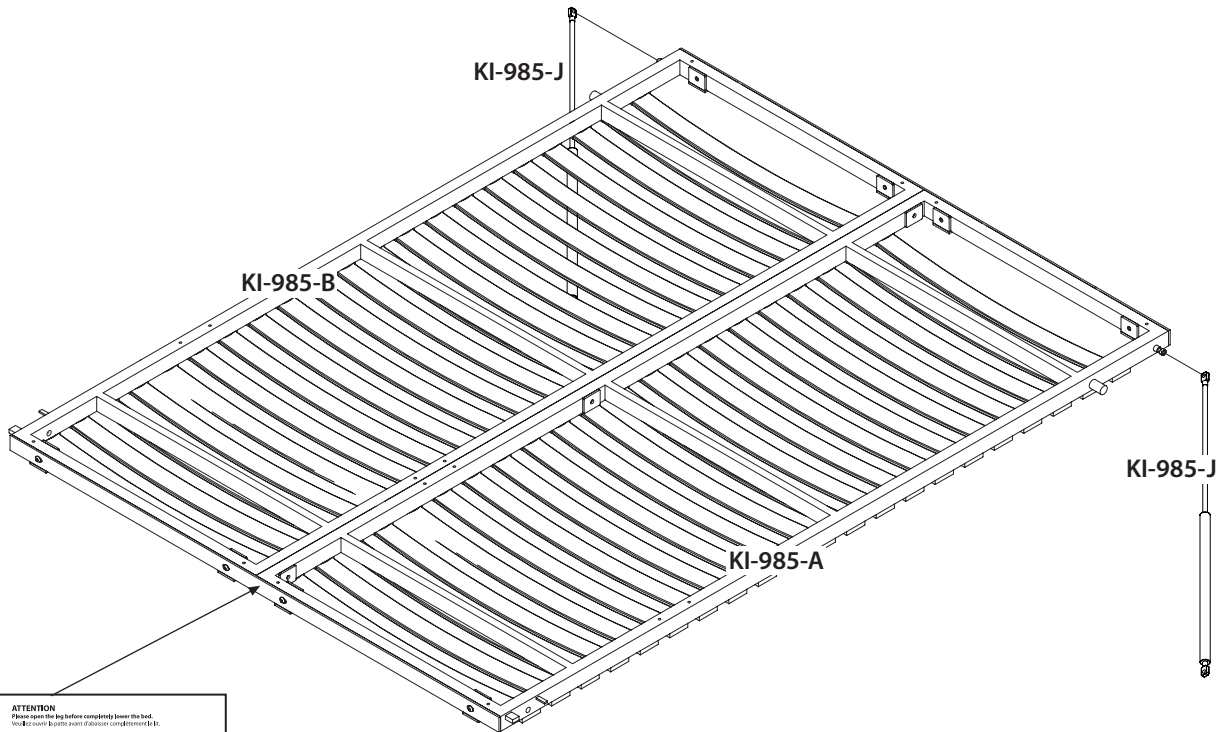
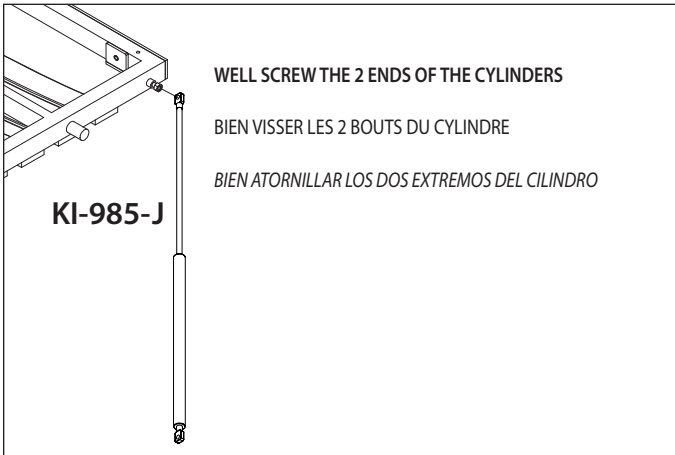

Code / Código

KI-985-J

Qty / Qté / Cant.

x 2

LEG WARNING STICKER  
ÉTIQUETTE AVERTISSEMENT DE LA PATTE  
ETIQUETA DE ADVERTENCIA DE LA PIERNA

x 1



## Important/Importante

1. Place the bearings equal on each side before fixing them up.
2. Well positioning the bearing support in such a way as to lock. (Image 1)
3. Tighten strongly the bearing support.

1. Positionner les roulements égaux de chaque côté avant de les fixer en place.
2. Bien positionner le support de roulement de manière à le bloquer. (Image 1)
3. Serrer fortement le support de roulement.

1. Coloque los rodamientos iguales a cada lado antes de fijar para arriba.
2. Bien posicionar el soporte de cojinete de tal manera como para bloquear. (Image 1)
3. Apriete firmemente el soporte de rodamiento.

INSERT MATTRESS SUPPORT  
INSÉRER LE SUPPORT À MATELAS  
INSERTE EL SOPORTE DEL COLCHÓN

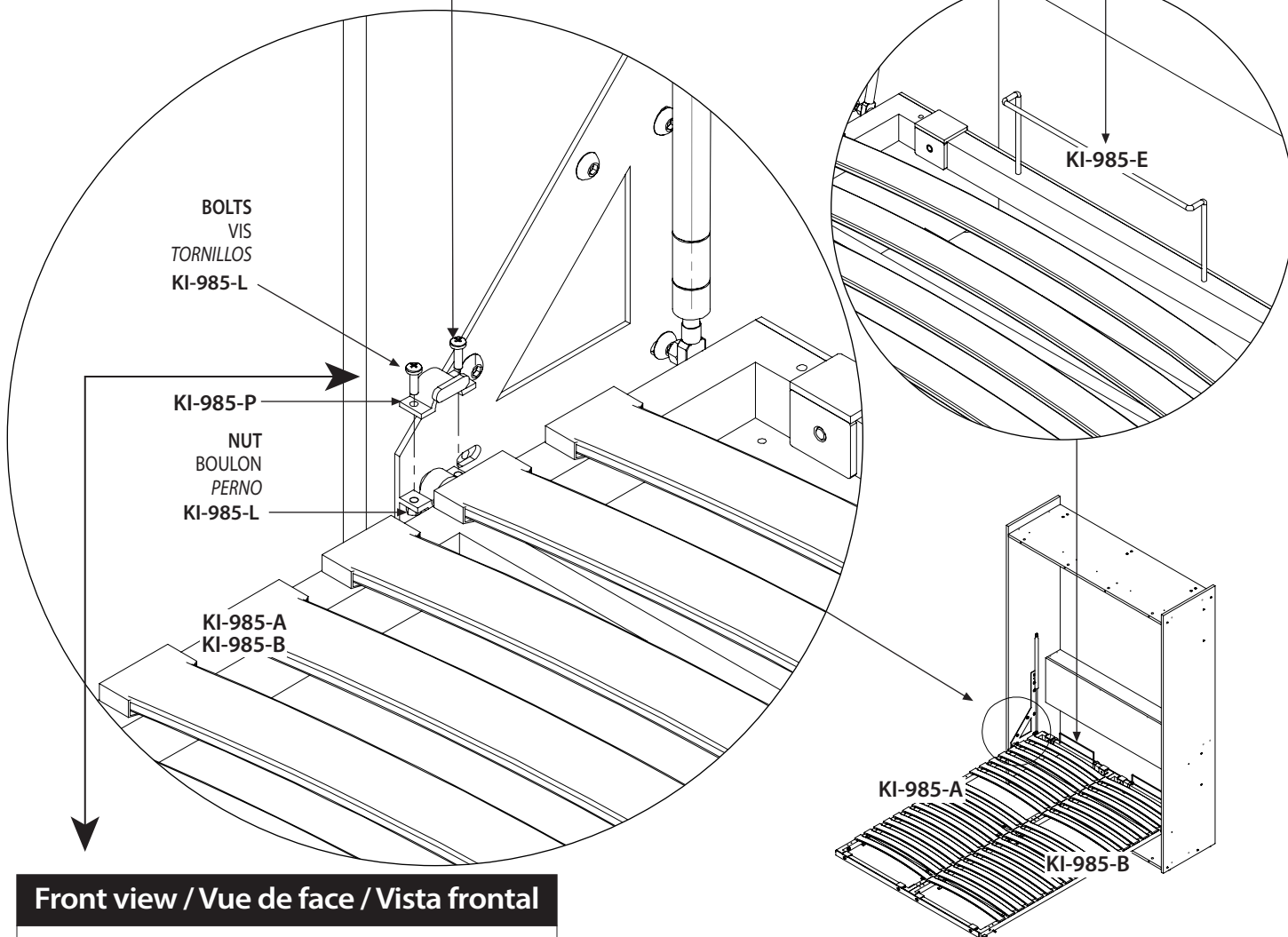

Front view / Vue de face / Vista frontal

Image 1

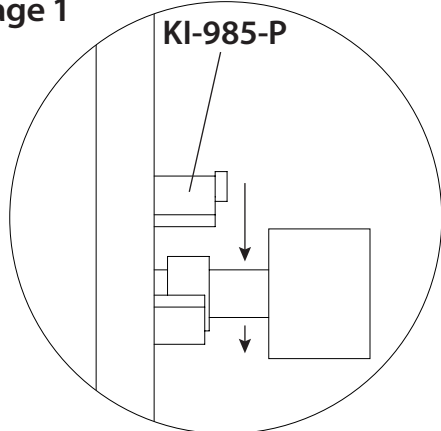

8



Code / Código  
KI-985-L

Qty / Qté / Cant. x 4



Code / Código  
KI-985-P

Qty / Qté / Cant. x 2

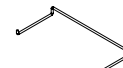

Code / Código  
KI-985-E

Qty / Qté / Cant. x 2

## Important/Importante

Prendre note qu'après l'installation des pistons, il sera très difficile d'ouvrir le lit. Continuez les étapes jusqu'à la fin, placez le matelas, et le lit s'ouvrira sans effort.

Take note that after the installation of the pistons, it will be very difficult to open the bed. Continue the steps until the end, put the mattress on, and the bed will open without effort.

Tomar nota que después de la instalación de los émbolos, será muy difícil de abrir la cama. Continúe las etapas hasta el fin, coloque el colchón, y la cama se abrirá sin esfuerzo.

INSERT CYLINDER ON ITS STEM / INSÉRER LE CYLINDRE SUR SA TIGE  
INSERTE EL CILINDRO EN SU TALLO

KI-985 must be completely tightened  
KI-985 doit être complètement serré  
KI-985 debe ser completamente apretado

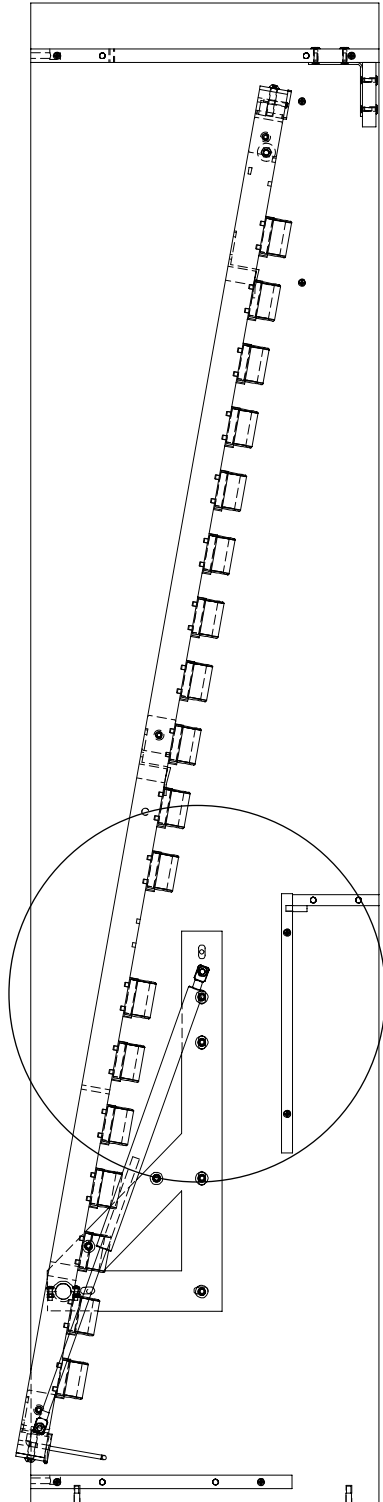
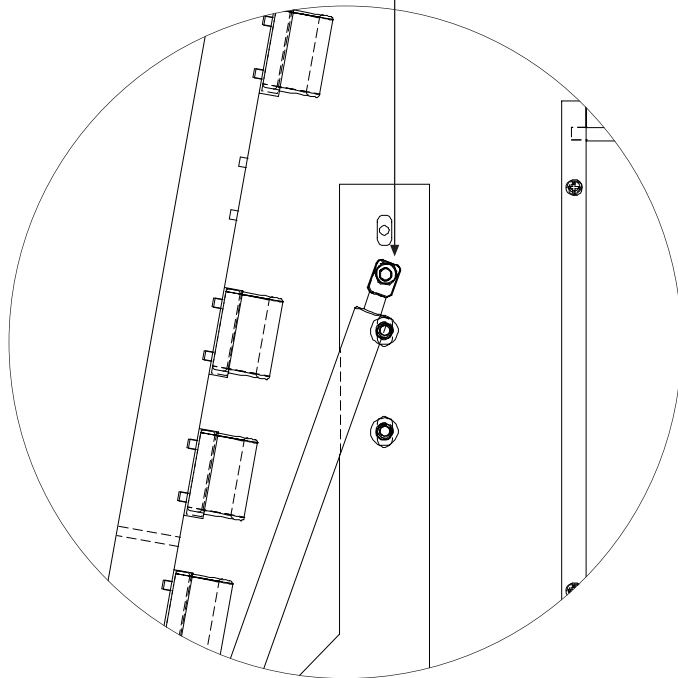
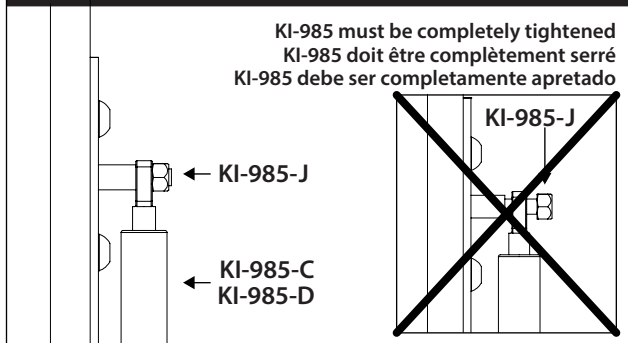

**Important/Importante**

Use one of the cardboard corner pieces from packaging or similar object to keep the bed in semi-closed position for facades installation.

Utilisez une des pièces de carton en coin de l'emballage ou un objet similaire afin de maintenir le lit en position semi-fermé pour l'installation des façades.

Utilice una de las piezas de las esquinas de cartón de embalaje o un objeto similar para mantener la cama en posición semi-cerrado para la instalación de fachadas.

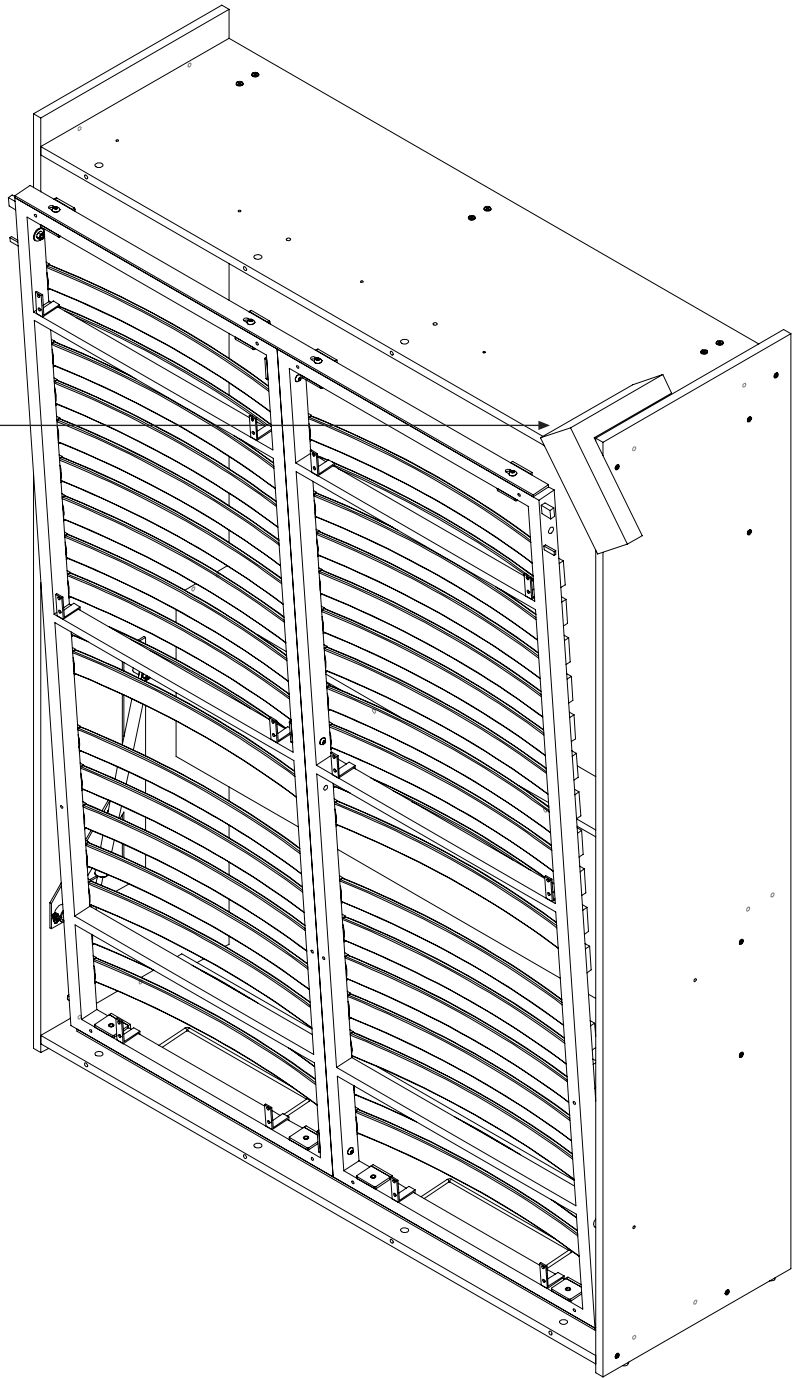



Assembling sequence  
 Séquence d'assemblage  
 Secuencia de ensamblaje  
 Parts / Pièces / Piezas:

41 + 81

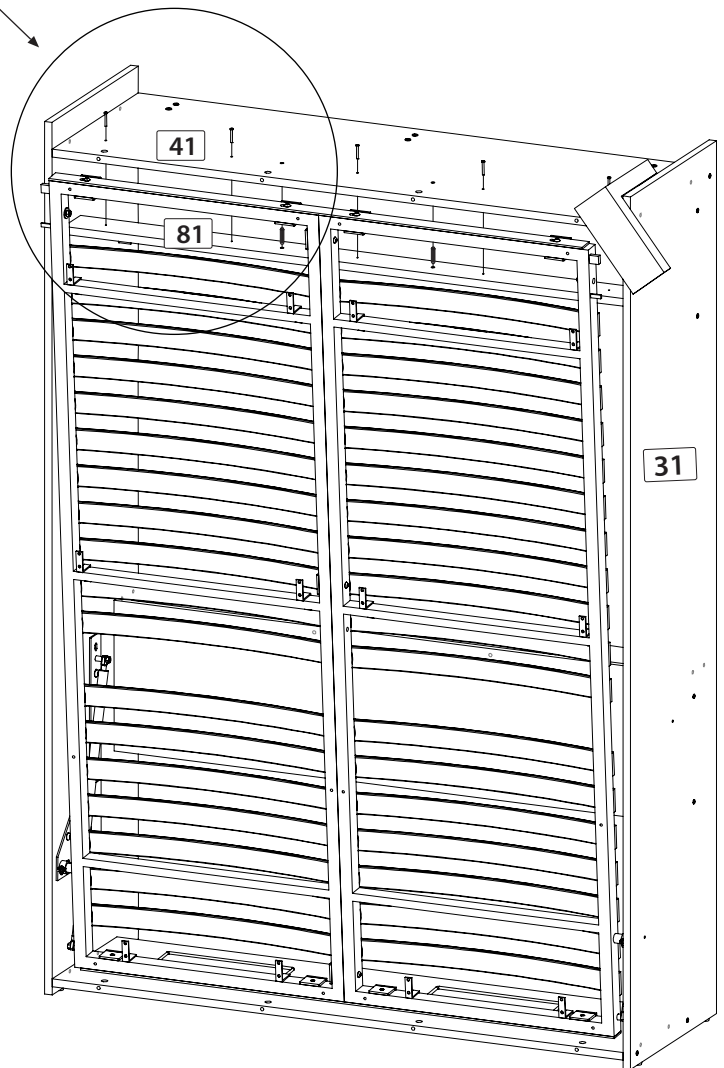
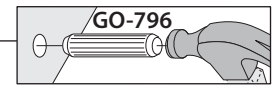
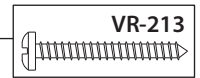
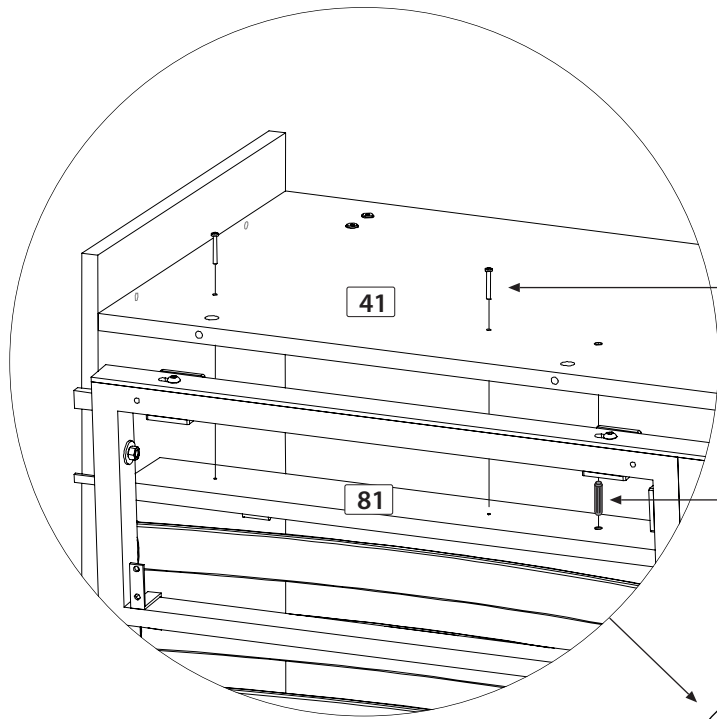

Code / Código VR-213

Qty / Qté / Cant. x 5



Code / Código GO-796

Qty / Qté / Cant. x 2

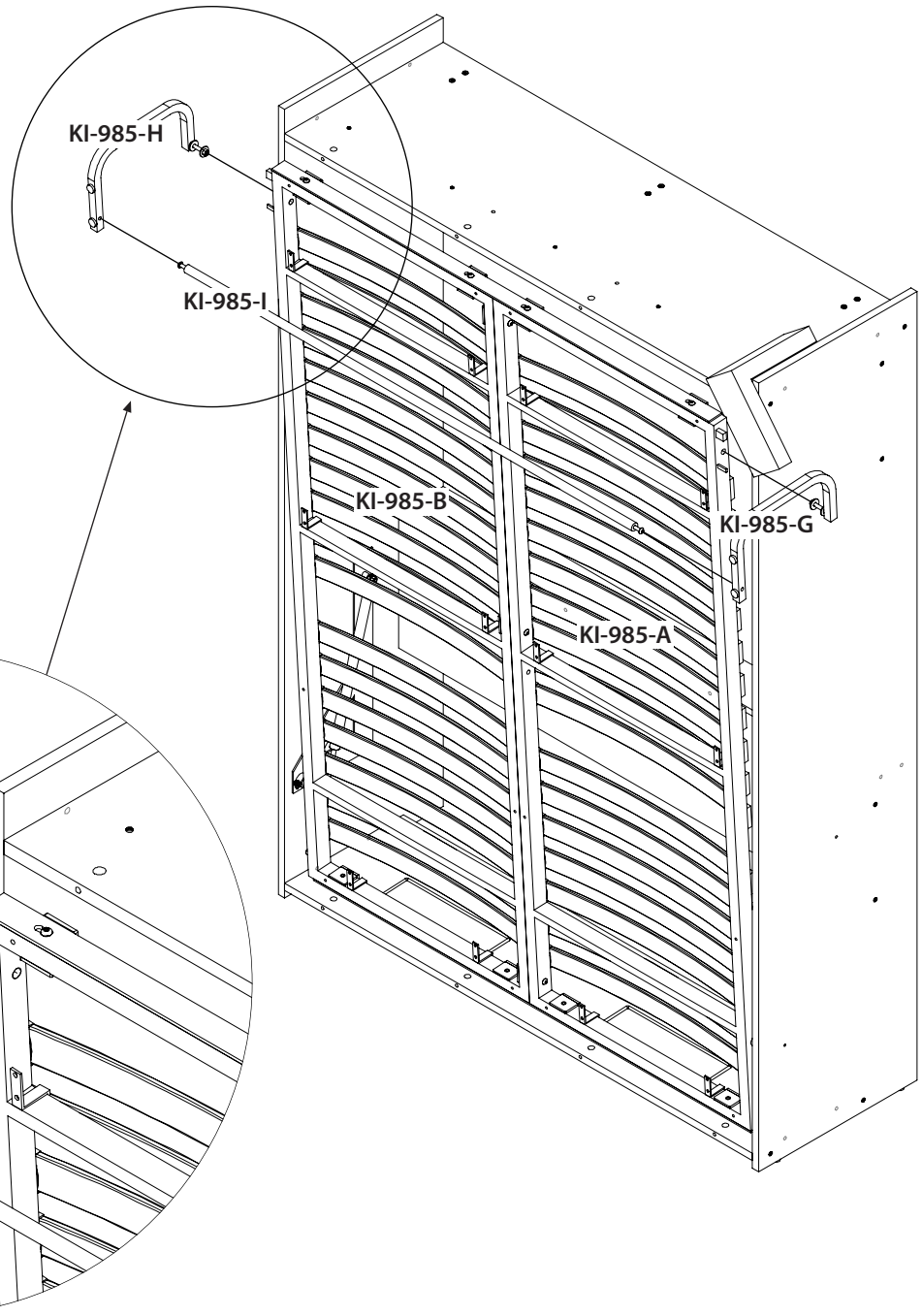

Code / Código

KI-985-G

KI-985-H

KI-985-I

Qty / Qté / Cant.

x 1

x 1

x 1



**Assembling sequence**  
 Séquence d'assemblage  
 Secuencia de ensamblaje  
**Parts / Pièces / Piezas:**



**31 40 30**

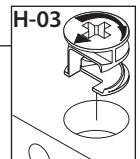
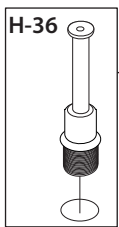
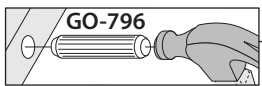
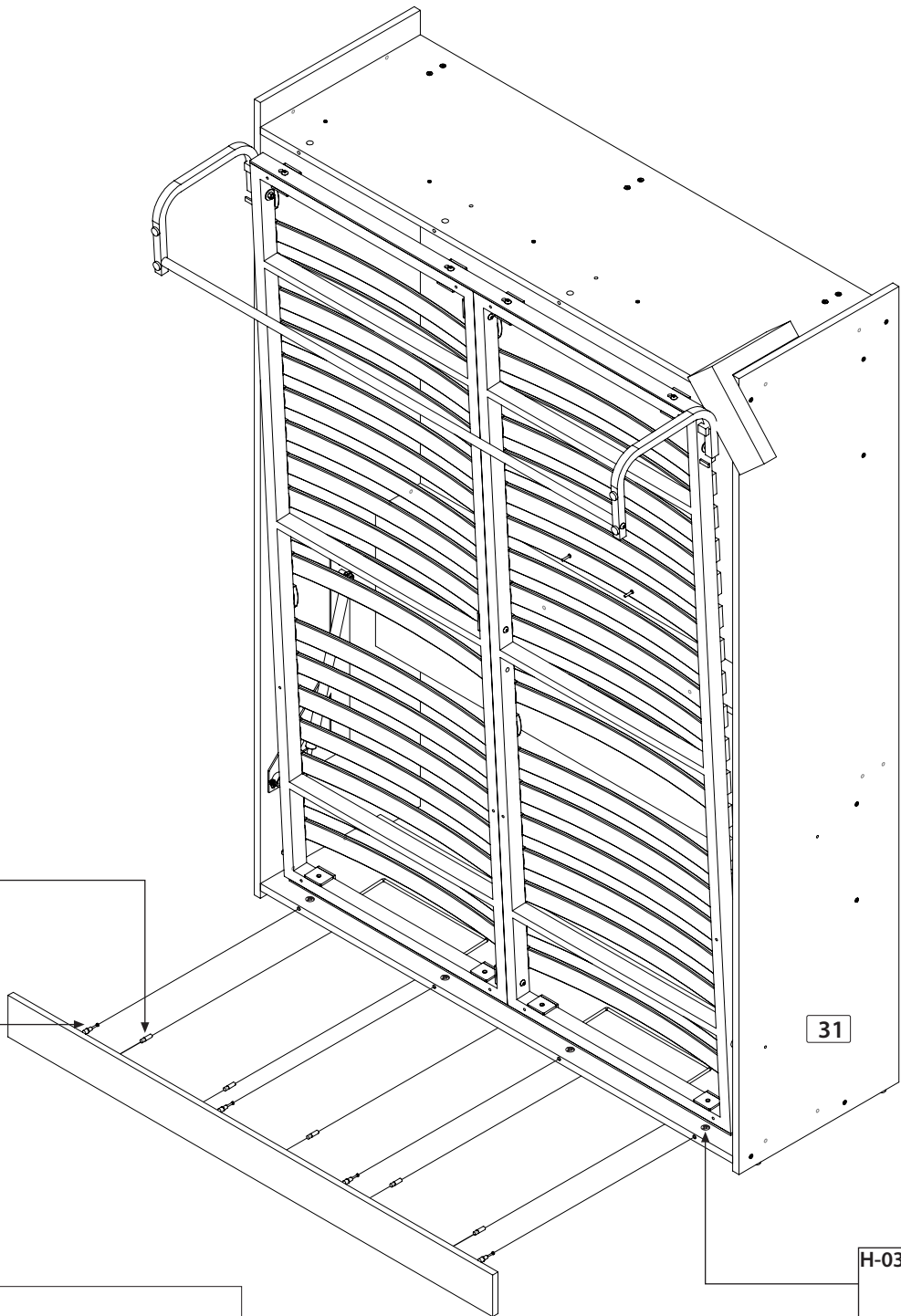

**13**

| Code / Código     | GO-796 | H-03 | H-36 |
|-------------------|--------|------|------|
| Qty / Qté / Cant. | x 5    | x 4  | x 4  |



+ 60

FRONT VIEW  
VUE DE FACE  
VISTA FRONTAL

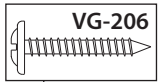
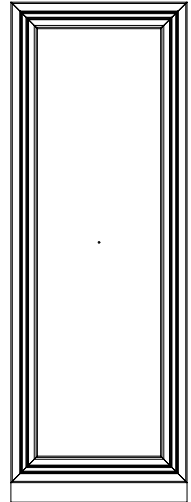

3x

60

3500-400350

KI-985-K

60

VF-229

PO-777

1451 mm

532 mm

14



Code / Código

KI-985-K

PO-777

VF-229

VG-206

3500-400350

Qty / Qté / Cant.

x 12

x 3

x 3

x 30

x 24



+ 61

FRONT VIEW  
VUE DE FACE  
VISTA FRONTAL

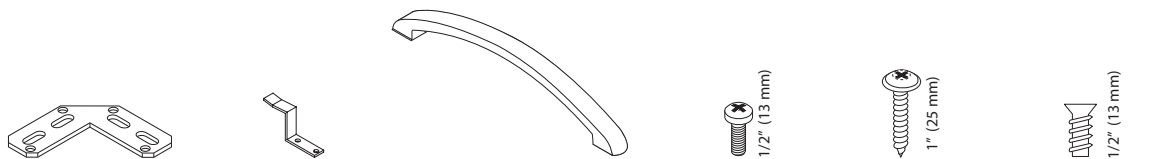
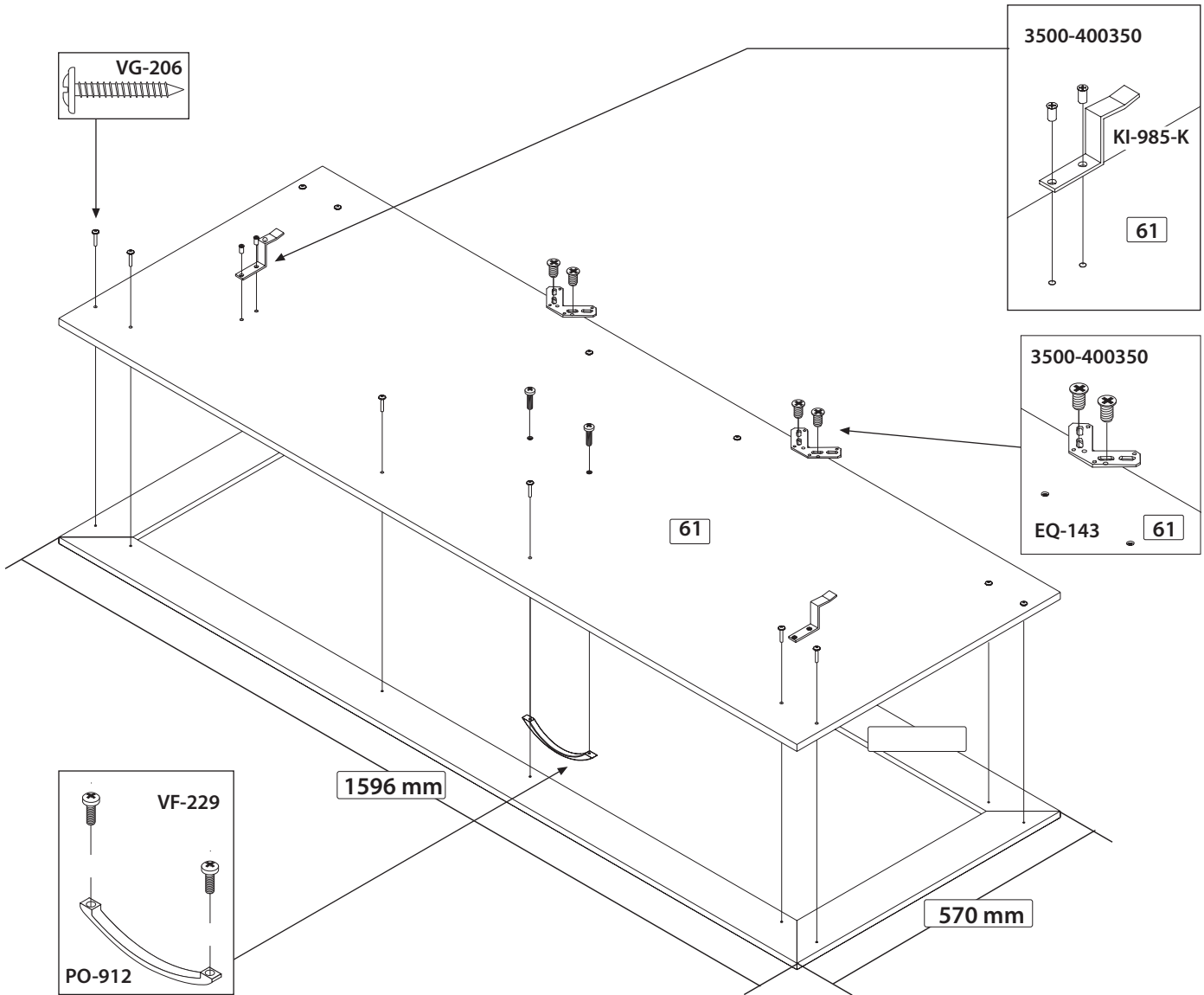
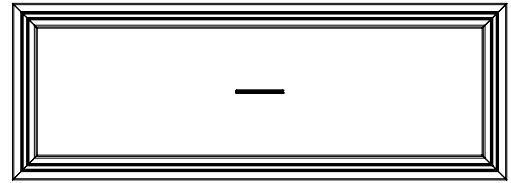

| Code / Código     | EQ-143 | KI-985-K | PO-912 | VF-229 | VG-206 | 3500-400350 |
|-------------------|--------|----------|--------|--------|--------|-------------|
| Qty / Qté / Cant. | x 2    | x 2      | x 1    | x 2    | x 12   | x 8         |



### Important/Importante

Rotate the leg towards the interior.  
Faire pivoter la patte vers l'intérieur.  
Gire la pata para el interior.

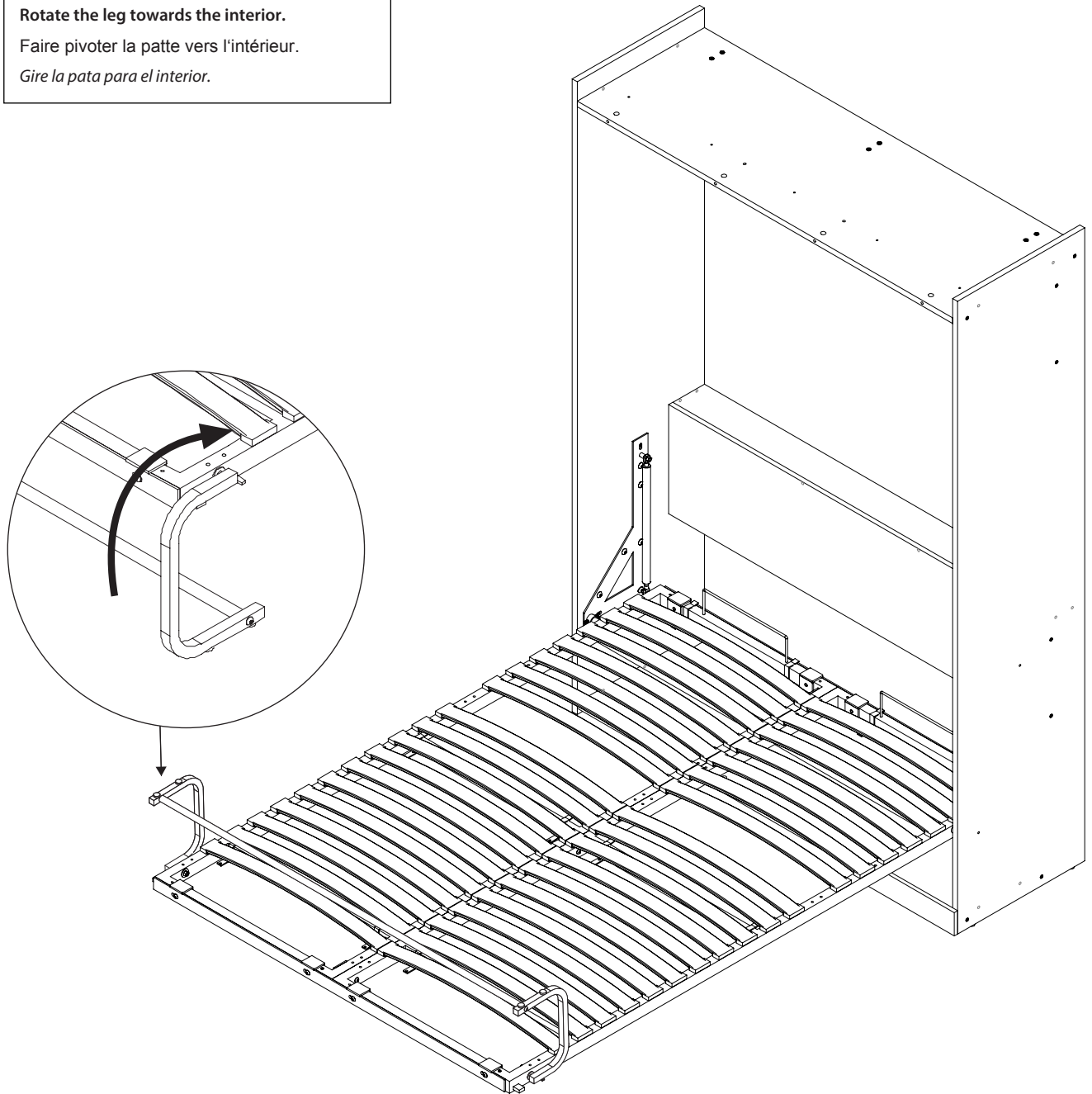

**Assembling sequence**  
 Séquence d'assemblage  
 Secuencia de ensamblaje  
 Parts / Pièces / Piezas:



KI-985-A KI-985-B + 60 + 60 + 60

### Important/Importante

Use one of the cardboard corner pieces from packaging or similar object to keep the bed in semi-closed position for facades installation.

Utilisez une des pièces de carton en coin de l'emballage ou un objet similaire afin de maintenir le lit en position semi-fermé pour l'installation des façades.

Utilice una de las piezas de las esquinas de cartón de embalaje o un objeto similar para mantener la cama en posición semi-cerrado para la instalación de fachadas.

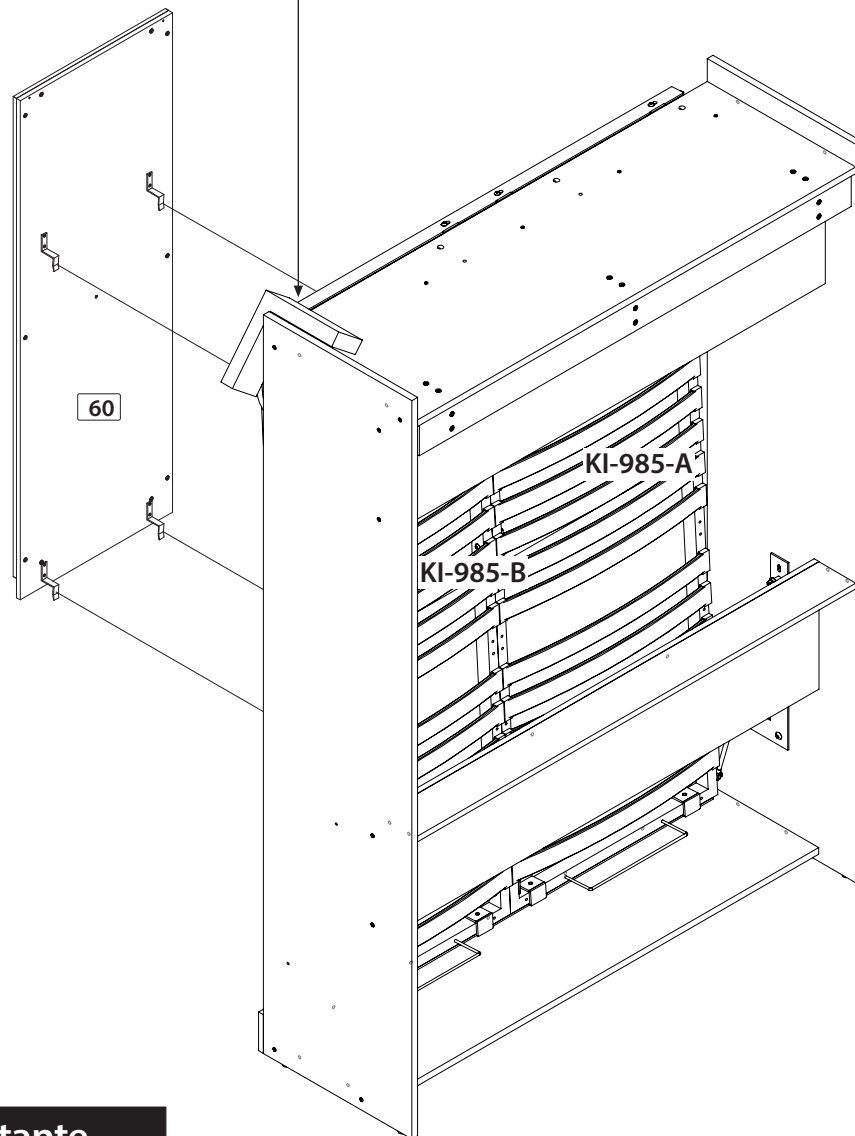

### Important/Importante

Refer to step 18 for details.

Référez-vous à l'étape 18 pour plus de détails.

Consulte el paso 18 para obtener más información.

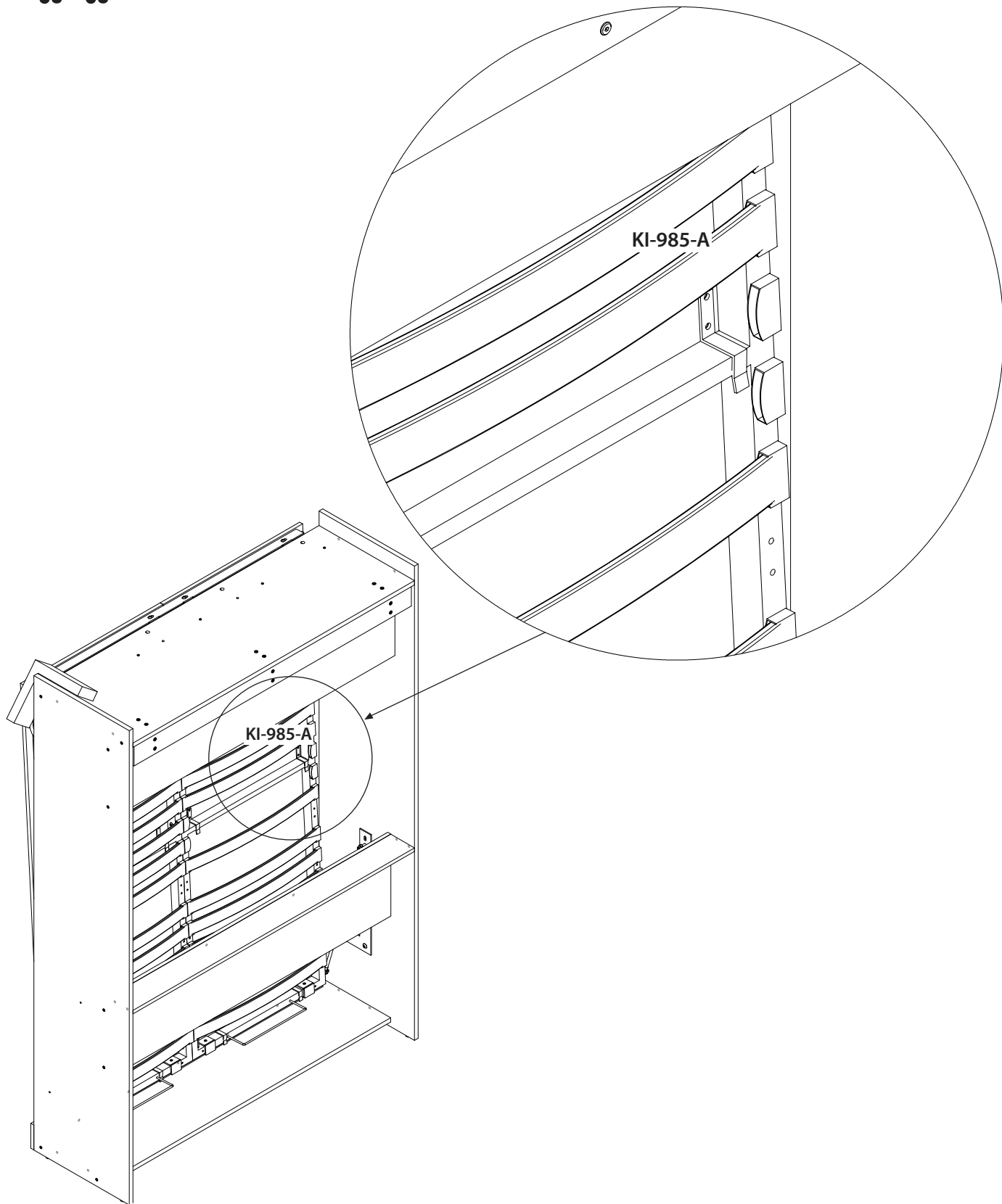

Assembling sequence  
Séquence d'assemblage  
Secuencia de ensamblaje  
Parts / Pièces / Piezas:



KI-985-A KI-985-B + 61

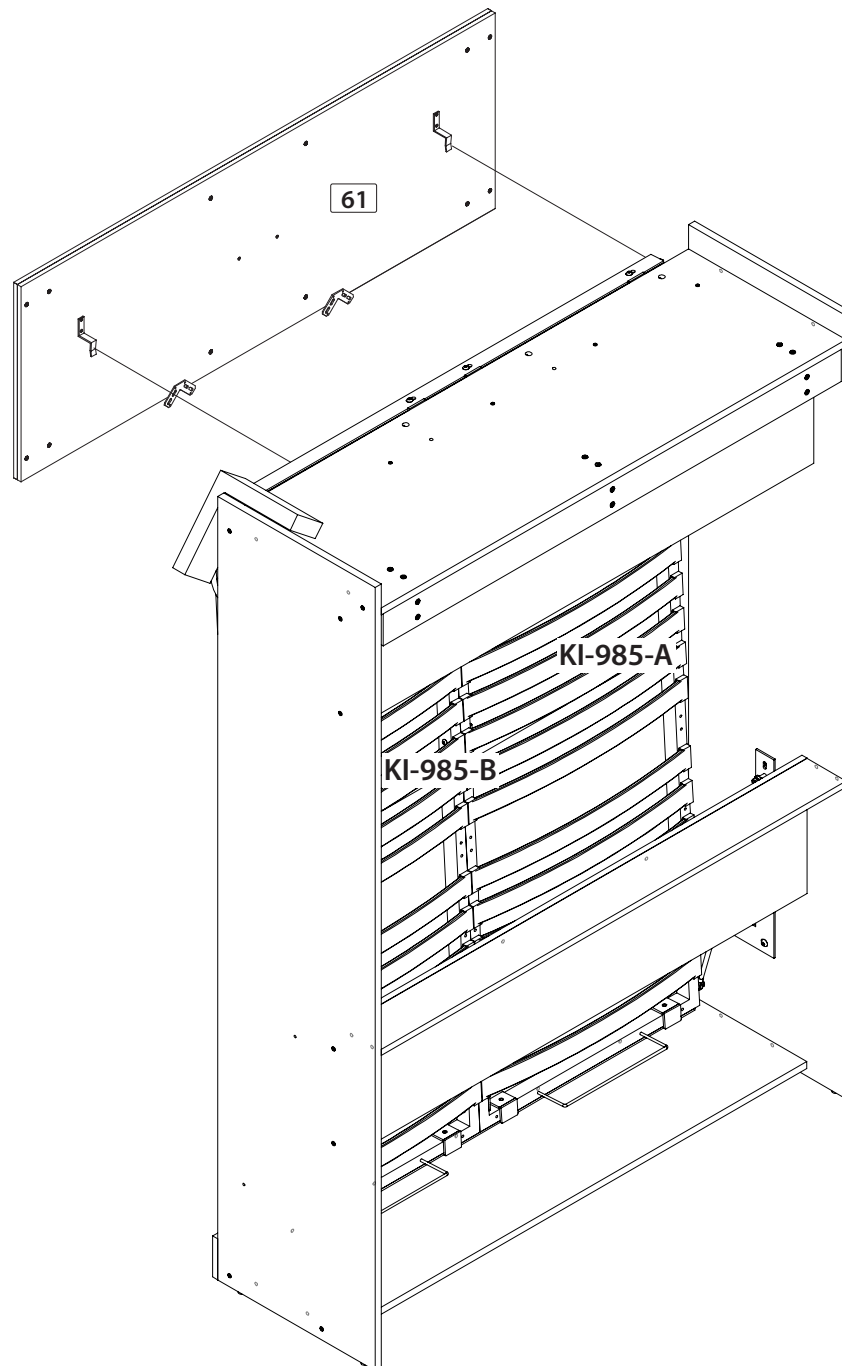

**CAUTION / ATTENTION / ATENCIÓN**

Please open the leg before completely lower the bed.  
 Veuillez ouvrir la patte avant d'abaisser complètement le lit.  
 Por favor, abra la pierna delantera bajar completamente la cama.

**Important/Importante**

Center the bed before screwing in parts 60 and 61.  
 Centrez le lit avant de visser dans les pièces 60 et 61.  
 Centre la cama antes de atornillar las piezas 60 y 61.

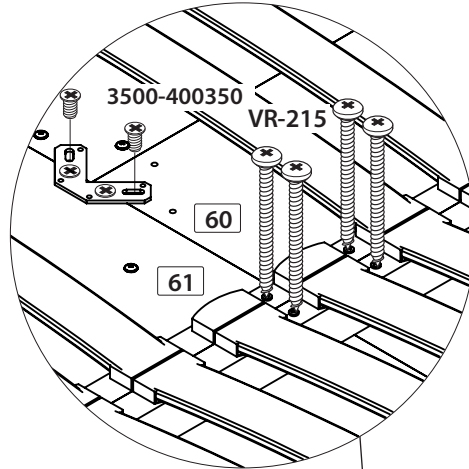

**Important/Importante**

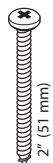
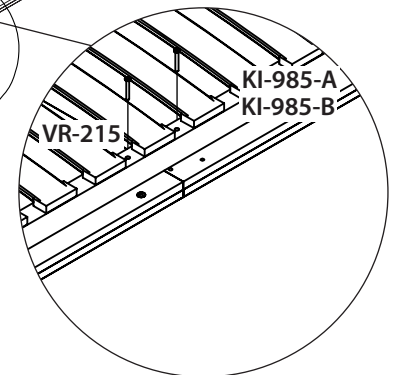
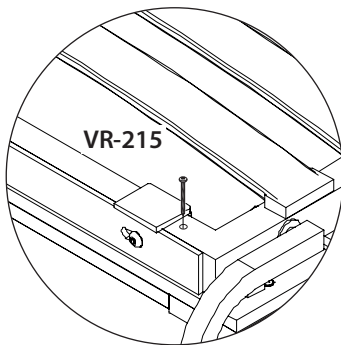
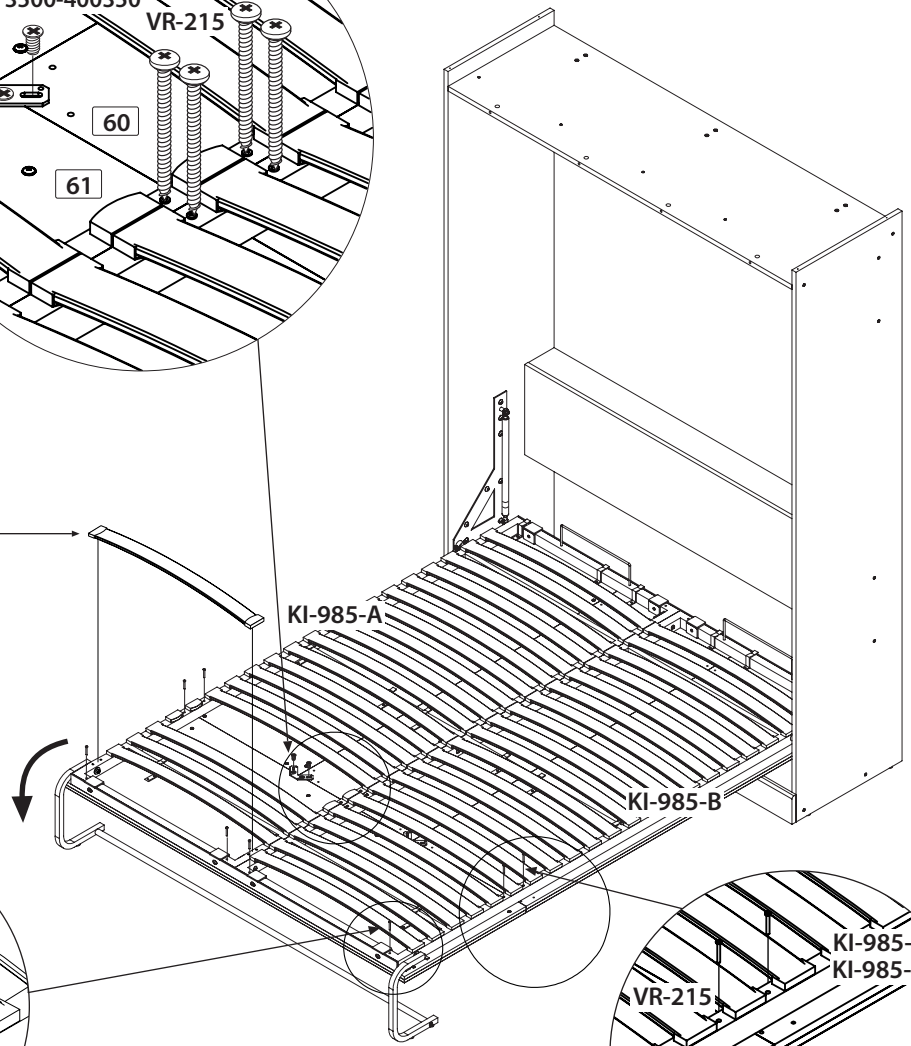
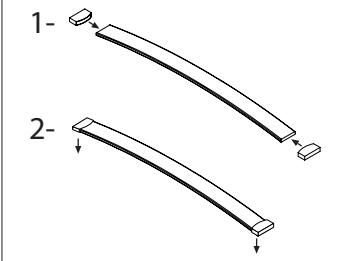

Code / Código VR-215

Qty / Qté / Cant. x 12



Code / Código 3500-400350

Qty / Qté / Cant. x 4



Code / Código KI-985-R

Qty / Qté / Cant. x 4



Code / Código KI-985-S

Qty / Qté / Cant. x 8



Assembling sequence  
Séquence d'assemblage  
Secuencia de ensamblaje  
Parts / Pièces / Piezas:

41 + 85

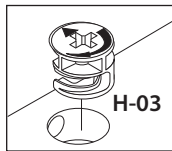

H-03

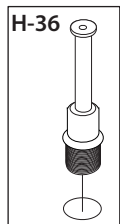

H-36

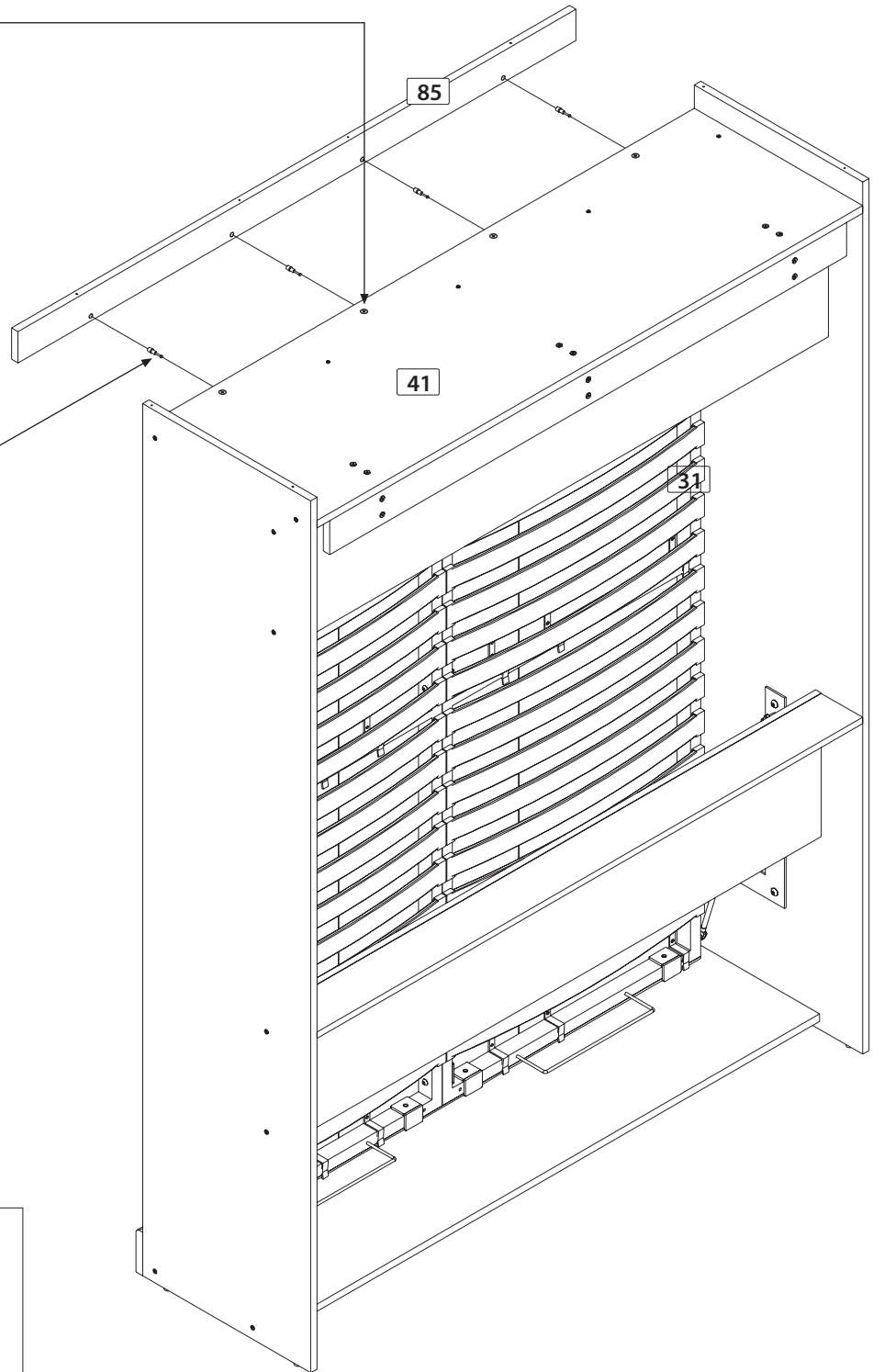

Code / Código



H-03

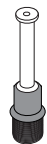

H-36

Qty / Qté / Cant.

x 4

x 4

Assembling sequence  
 Séquence d'assemblage  
 Secuencia de ensamblaje  
 Parts / Pièces / Piezas:



30 85 31

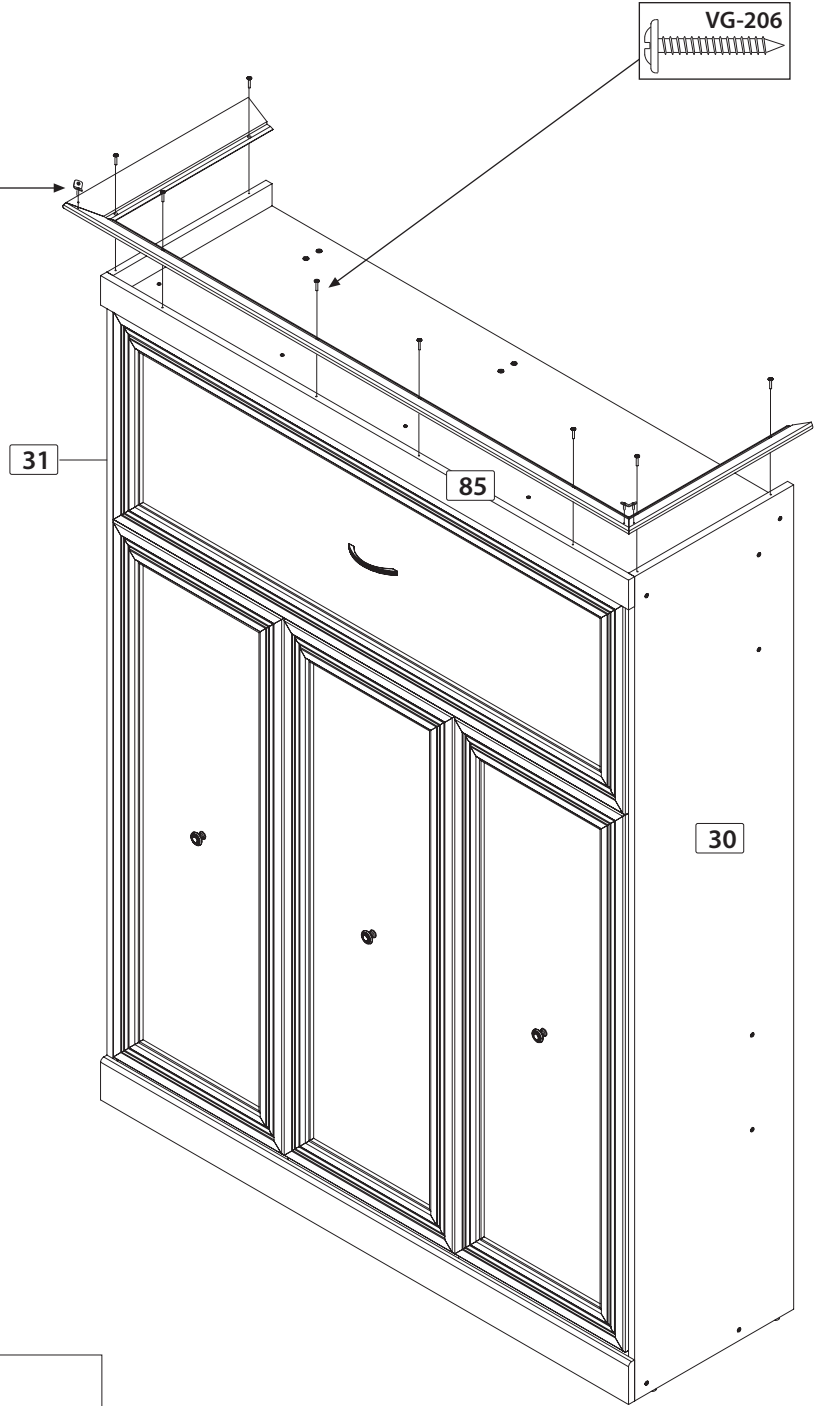
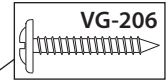
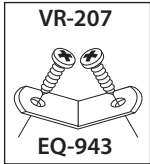

**IMPORTANT / IMPORTANTE**  
 Assure that the height of the ceiling is at least 93" (2362 mm) before installing the mouldings. Install the mouldings before or after having raised the bed according to the height of the ceiling.  
 Assurez-vous que la hauteur du plafond est d'au moins 93" (2362 mm) avant d'installer les moulures. Installez les moulures avant ou après avoir relevé le lit selon la hauteur du plafond.  
 Asegúrese que la altura del techo es de por lo menos 93" (2362 mm) antes de instalar las molduras. Instale las molduras antes o después haber levantado la cama según la altura del techo.

|                   |        |                      |                        |
|-------------------|--------|----------------------|------------------------|
| Code / Código     | EQ-943 | VG-206<br>1" (25 mm) | VR-207<br>1/2" (13 mm) |
| Qty / Qté / Cant. | x 2    | x 8                  | x 4                    |

**IMPORTANT / IMPORTANTE**

**DON'T APPLY PRESSURE ON FACADES**  
**NE PAS APPLIQUER DE CHARGE SUR LES FAÇADES.**  
*NO APLIQUE PRESIÓN EN FACHADAS*

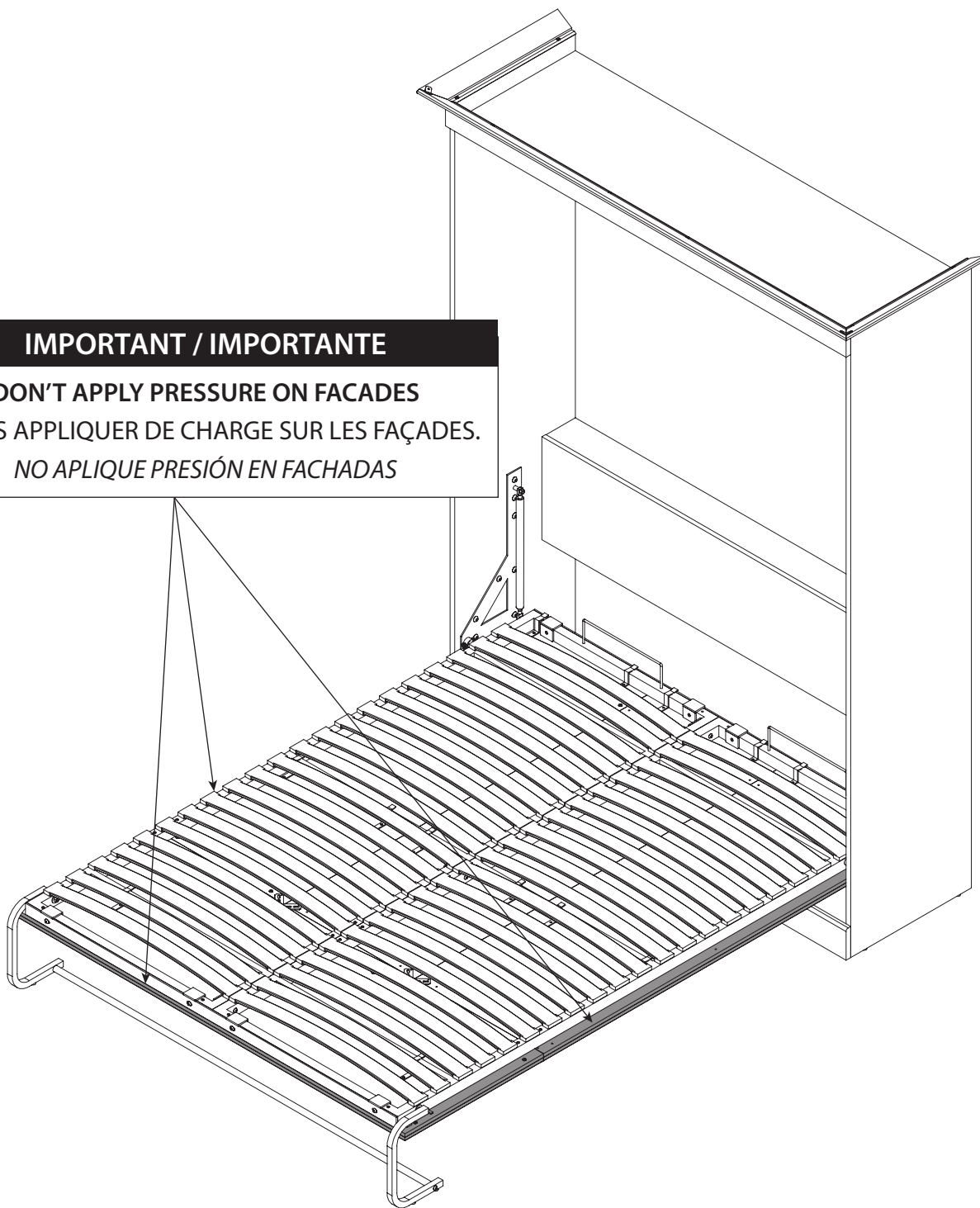

## IMPORTANT NOTICE / NOTE IMPORTANTE / NOTA IMPORTANTE

After you have finished assembling your wall bed, please keep the assembly book by placing it under the mattress, in the frame of the mobile part of the bed.

Lorsque l'assemblage de votre lit escamotable est terminé, veuillez conserver le feuillet d'instructions en le plaçant sous le matelas, dans le cadre de la partie mobile du lit.

Cuando el ensamble de su cama se acaba, por favor, conserve la hoja de instrucciones colocándolo bajo el colchón, en el marco de la parte móvil de la cama.

After you have finished assembling your wall bed, close it. If the gap around the bed is uneven, push or gently kick the base of the CABINET on the side with the NARROWEST gap until desired gap is obtained.

Lorsque l'assemblage de votre lit escamotable est terminé, fermez le lit. Si l'espace autour du lit est décentré, poussez ou frappez délicatement sur la BASE du côté où l'espace est le plus MINCE jusqu'à ce que l'espace désiré soit obtenu.

Cuando el ensamble de su cama se acaba, por favor, cama cercana. Si el espacio alrededor de la cama es descentrado, crezca o llame delicadamente teniendo como base el lado donde el espacio más DELGADO hasta que el espacio deseado sea obtenido.

## RECOMMENDATION / RECOMMANDATION / RECOMENDACIÓN

Maintain the bed closed when not used.

It is recommended not to leave pillows and/or ornamental pillows in place when the bed is closed to preserve the mechanism.

Maintenir le lit fermé lorsque non utilisé.

Il est recommandé de ne pas laisser les oreillers et/ou coussins décoratifs en place lorsque le lit est fermé afin de préserver le mécanisme de bascule.

Mantener la cama cerrada si cuando no utilizado.

Es recomendado no dejar las almohadas y/o los cojines decorativos en plaza cuando la cama es cerrada con el fin de preservar el mecanismo de báscula.

When you have completed the assembly of your new furniture, install the plastic caps

Lorsque vous avez complété l'assemblage de votre meuble, installez les capuchons de plastique

Una vez que haya ensablado el mueble, coloque los capuchones de plástico.

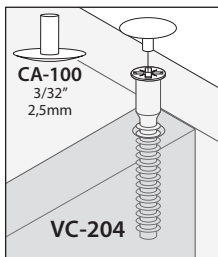

## PRODUCT CARE / ENTRETIEN DU PRODUIT / MANTENIMIENTO DEL PRODUCTO

Avoid placing the furniture in the sunlight or near a source of heat. Use a soft dry cloth for dusting. To clean heavy dirt, use a cloth dipped in a solution of mild detergent and water. Avoid leaving wet objects on the surface or using commercial chemical cleaning products.

Évitez d'exposer le meuble au soleil ou près de toute source de chaleur. Pour le nettoyage, utilisez un chiffon doux et sec. Pour la grosse saleté, utilisez un chiffon humide avec un peu de détergent dilué dans l'eau. Évitez de laisser des objets mouillés sur la surface de votre meuble ou d'utiliser des nettoyeurs chimiques.

Evite exponer el mueble al sol o las fuentes de calor. Para limpiarlo, utilice un paño suave y seco. Para limpiar las manchas rebeldes, utilice un trapo húmedo con un poco de detergente diluido en agua. No deje objetos mojados encima del mueble ni utilice limpiadores que contengan productos químicos.



**For more information or to discover our new products**

Pour toute information ou pour découvrir nos nouveaux produits

*Para más información o descubrir nuestros nuevos productos*



**FOR LONG TIME**  
**POUR LONGTEMPS**  
*POR MUCHO TIEMPO*