

SFT174

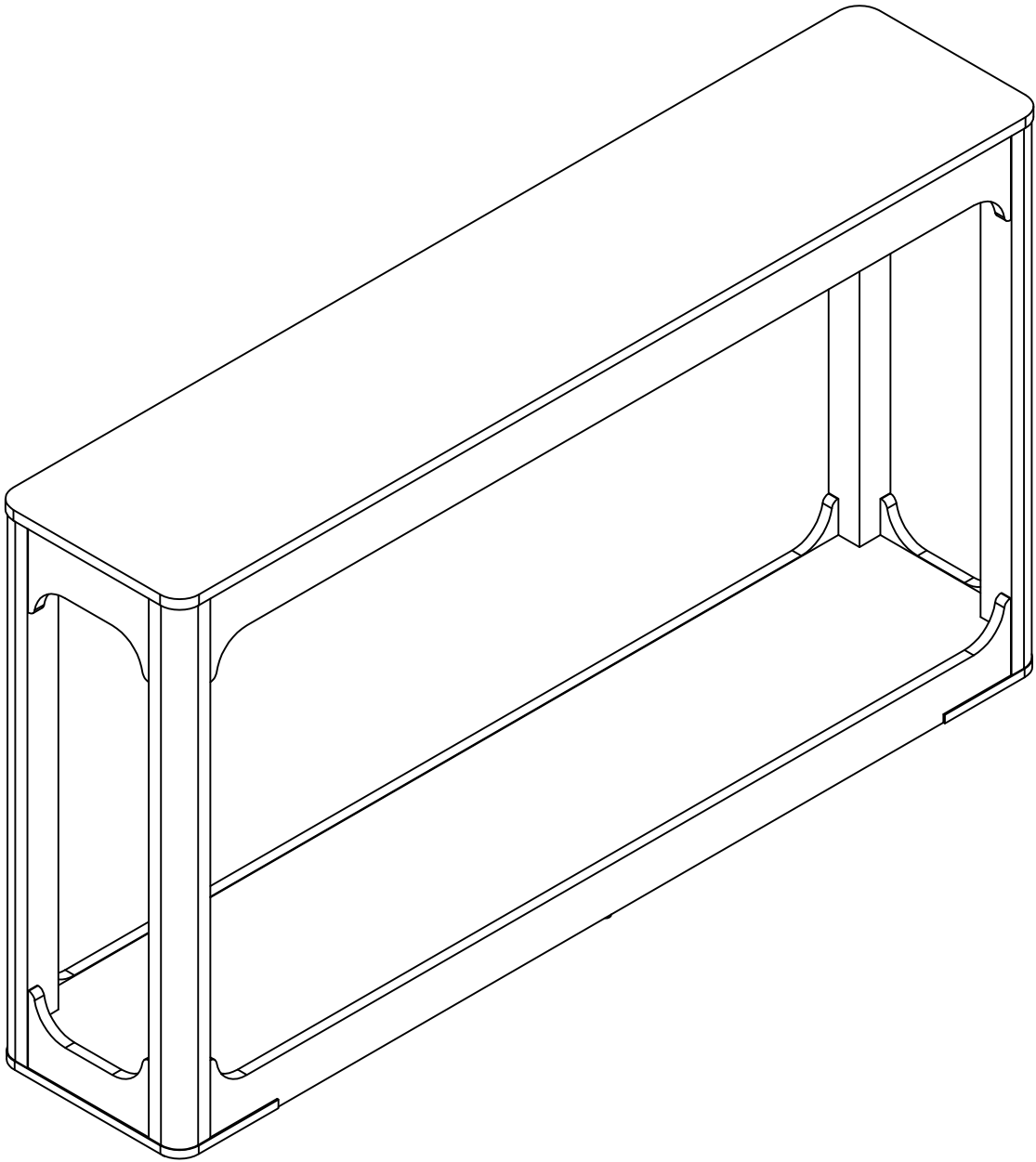

## General Guidelines

- Please read the following instruction carefully and use the product accordingly.
- Please keep this manual and hand it over when you transfer the product.
- This summary may not include every detail of all variations and considered steps. Please contact us when further information and help are needed.

## Notes

- The product is intended for indoor use only. The product must be assembled and used in accordance with the provisions of the manual. Personal injury and/or damage to product may occur if products are used outside of their intended purposes and/or if products have been changed/modified from their original design. The seller does not assume any responsibility or liability with respect to any injury/damage caused by incorrect assembly or improper use.
- Avoid long-term exposure to humid environments to prevent mildew.
- Keep the product away from fire sources and high temperatures. Do not expose the product to direct sunlight.
- Do not place any hot objects on the surface of the product.
- If there are any defective or missing parts after unpacking, please cease assembly immediately and contact us.
- Please assemble the item on a spacious surface and do not place the unwrapped product directly on the ground to avoid product damage.
- Please do not stand or sit on the wooden boards.
- Please wear gloves during the assembly and/or disassembly process to avoid scratches from any sharp edges.
- Please match the corresponding part and fitting based on the part number in the manual.
- If the part does not match with the fitting, please check the piece as specified in this manual.
- During assembly, first loosely align all screws with the corresponding pre-drilled holes and then tighten the screws one by one.
- Periodically inspect screw tightness while the product is in use. If necessary, retighten to ensure structural integrity.
- If you accidentally spill water or another liquid on the surface, immediately wipe clean with a dry towel.
- Please keep the product away from sharp, pointed objects and corrosive substances to prevent product damage.
- Please place this item on level, solid ground during use.

## Warnings

- During assembly, keep all small parts out of the reach of children. It may be fatal if swallowed or inhaled.
- Children should not climb or play on the product in order to avoid tipping over the furniture and causing serious injury.
- To avoid the potential dangers of suffocation, please keep all parts and packaging (film, plastic bags, foam, etc.) away from babies and children.
- Keep sharp objects and corrosive items away from the product to avoid any damage or injury.
- Do not shake or move violently during use to avoid tipping over the product.

# Parts List

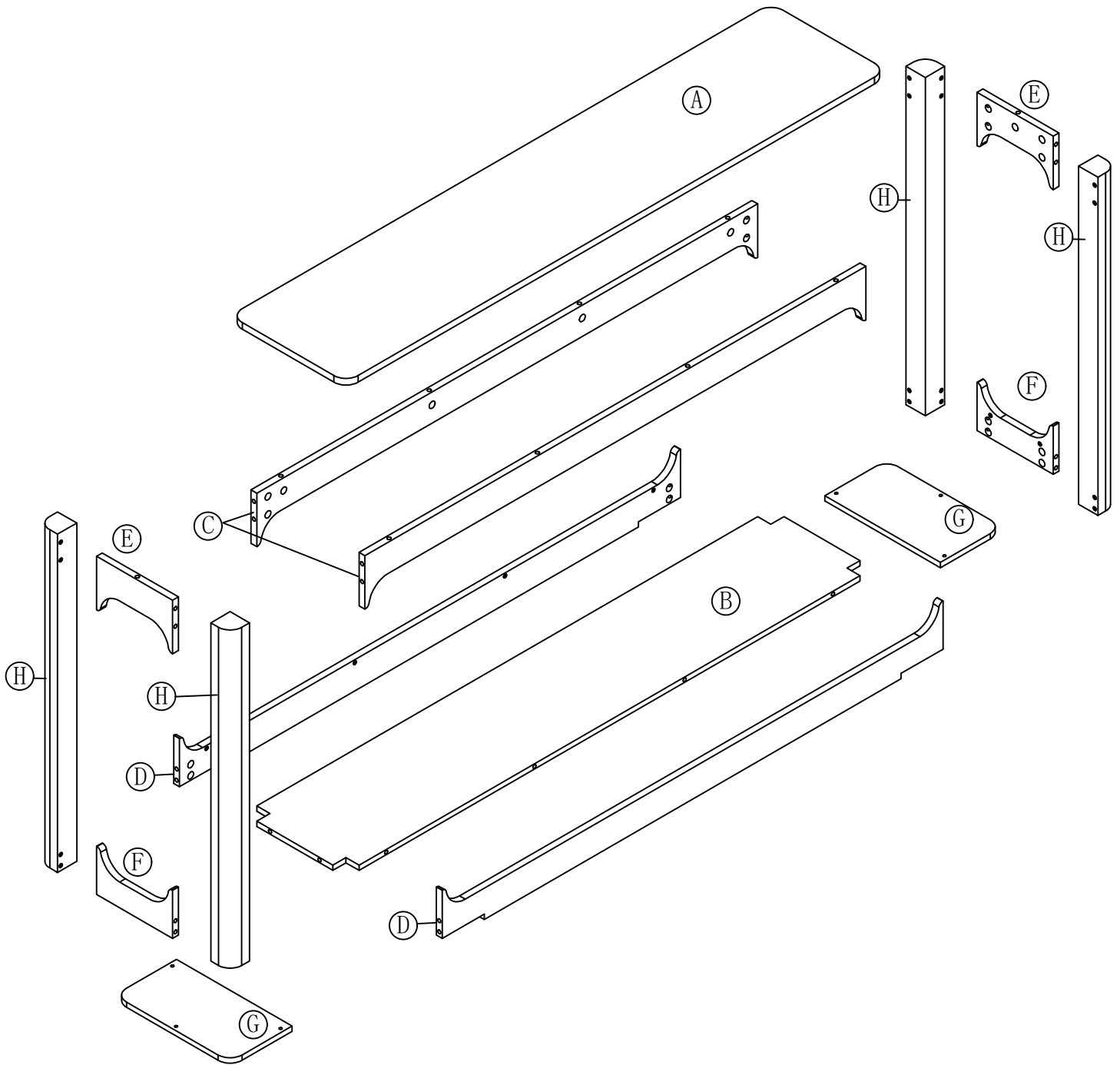

# Parts List

**A**

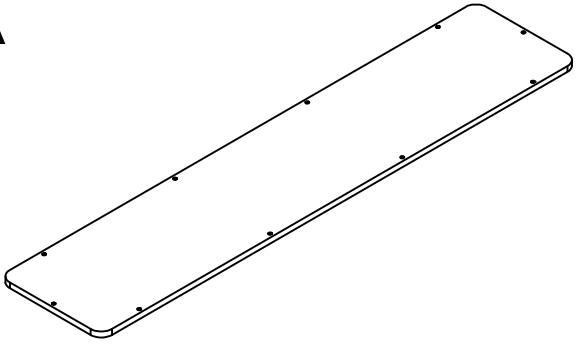

**X1**

**B**

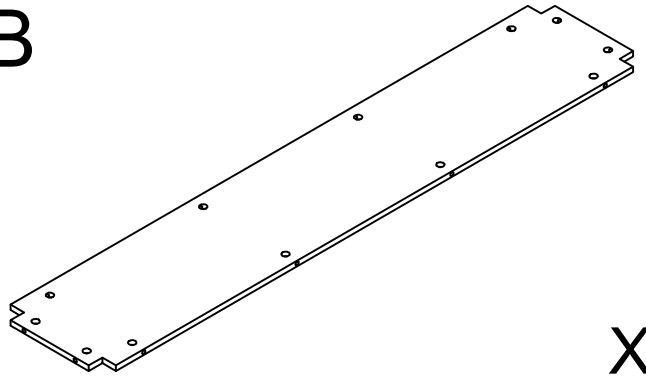

**X1**

**C**

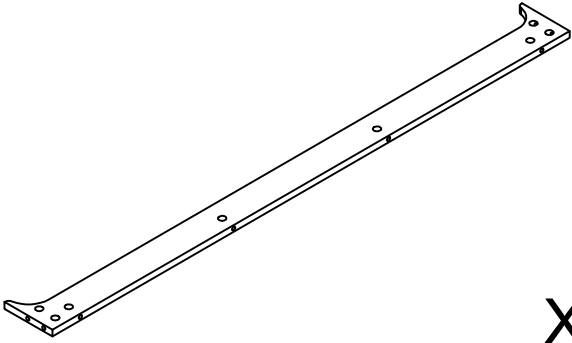

**X2**

**D**

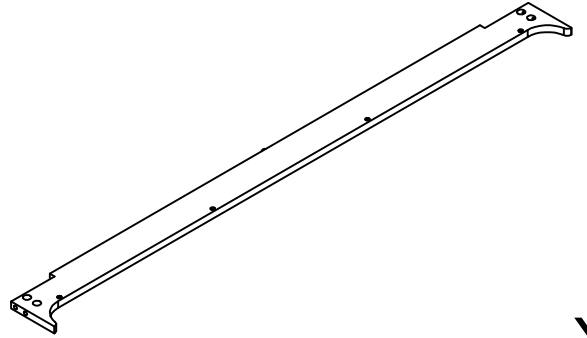

**X2**

**E**

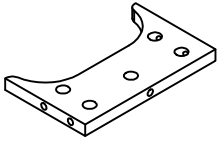

**X2**

**F**

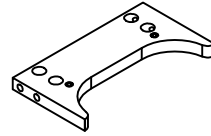

**X2**

**G**

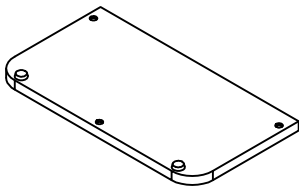

**X2**

**H**

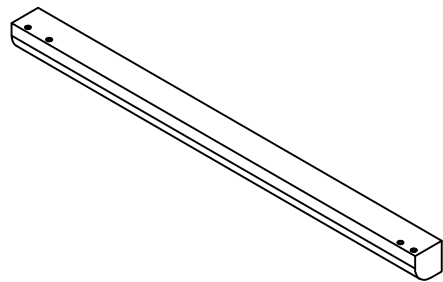

**X4**

# Hardware List

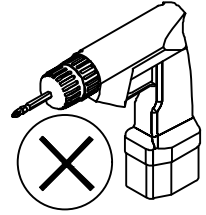
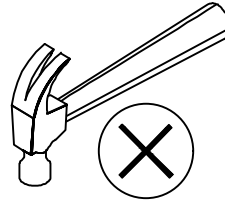
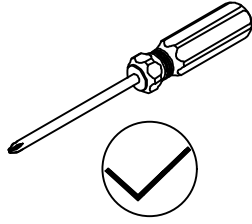
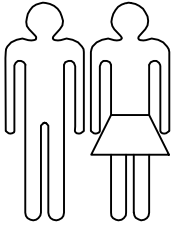

1

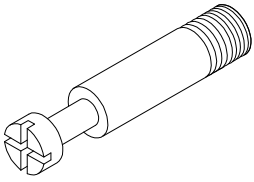

54+2PCS

2

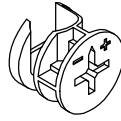

54+2PCS

3

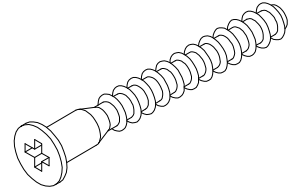

M5\*50 6+1PCS

4



26+2PCS

5

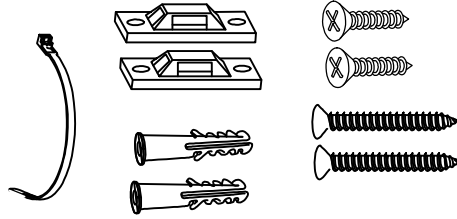

2set

# INSTALLING THE CAM LOCKS

1



*Do not over tighten!*

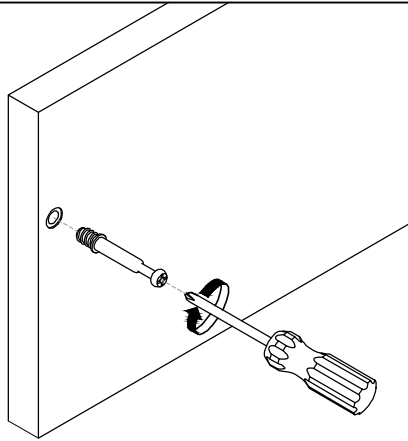

The base of the Cam Screw should be flush with the panel

2

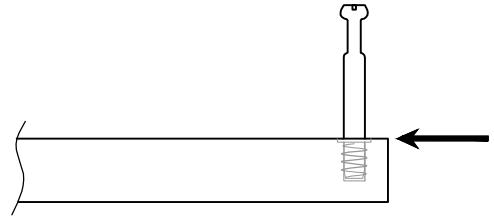

Screw the Cam Screw into the prethreaded hole. Tighten with a screwdriver until snug.

3

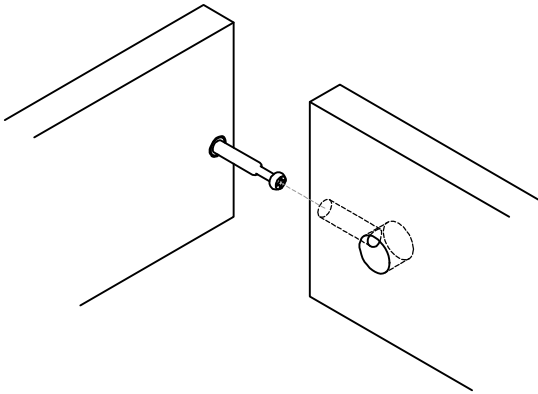

Connect the panels. Insert the Cam Screw into the small hole in the adjoining panel.

4

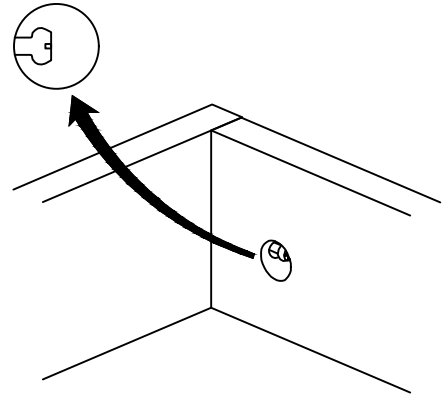

The head of the Cam Screw should be visible through the large hole.

5

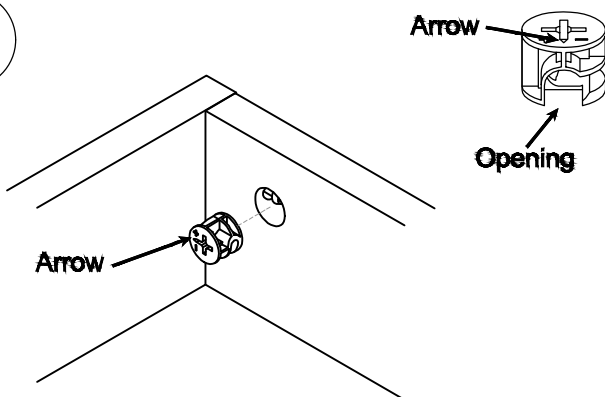

Insert the Cam Lock into the large hole. Make sure the arrow and the opening in the Cam Lock are facing the Cam Screw.

6

90°~180°



*Do not over tighten!*

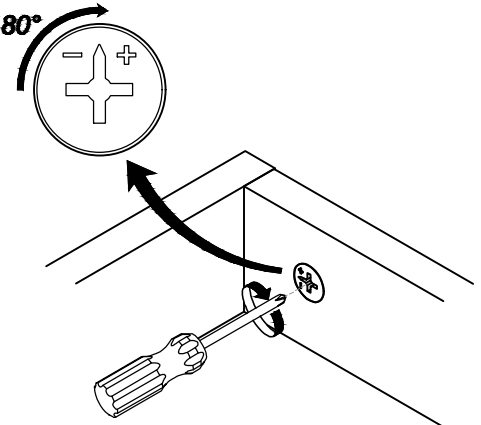

Using a screwdriver, turn the Cam Lock at least 90° clock-wise to lock the two panels firmly together

# Assemble steps

1

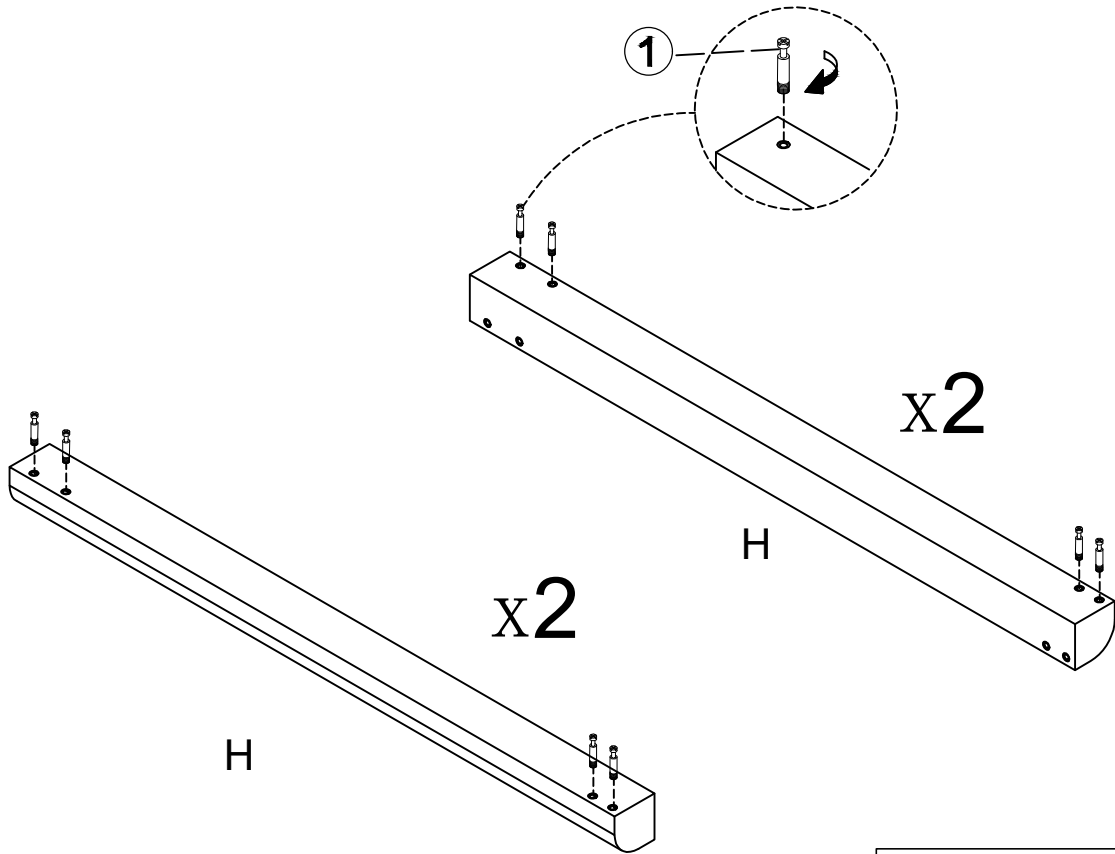

1

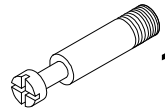

16PCS

2

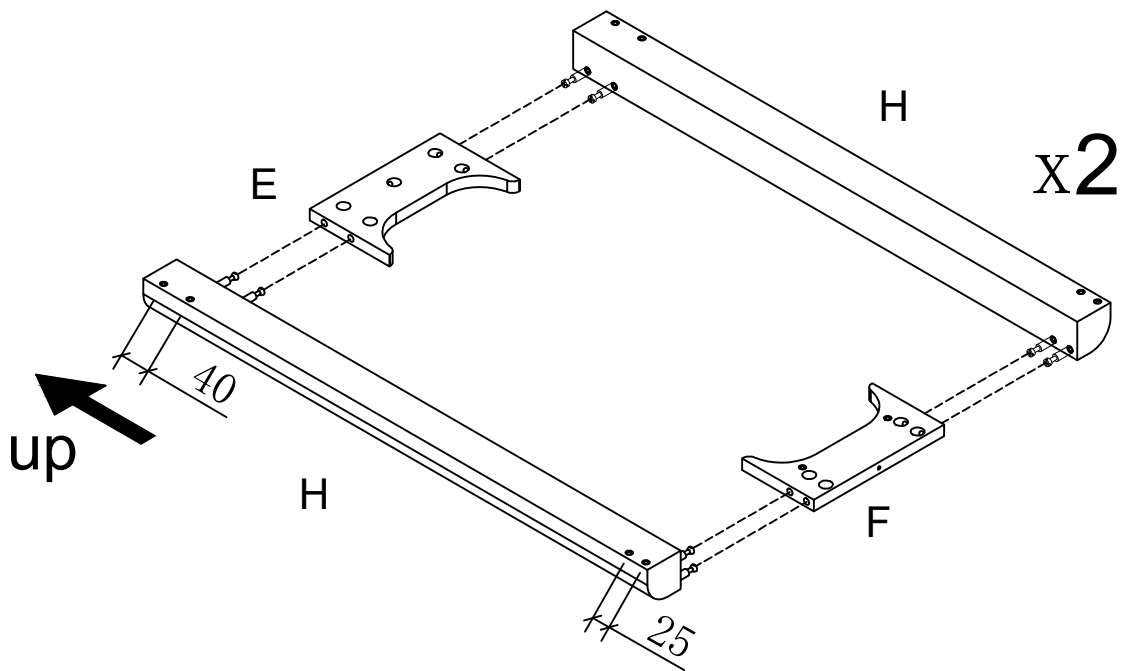

# Assemble steps

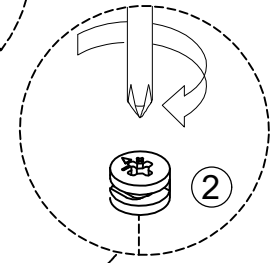
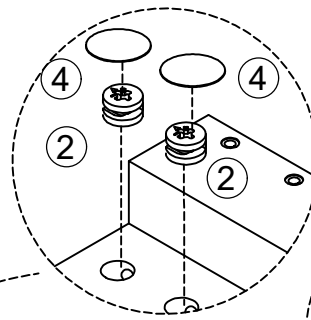
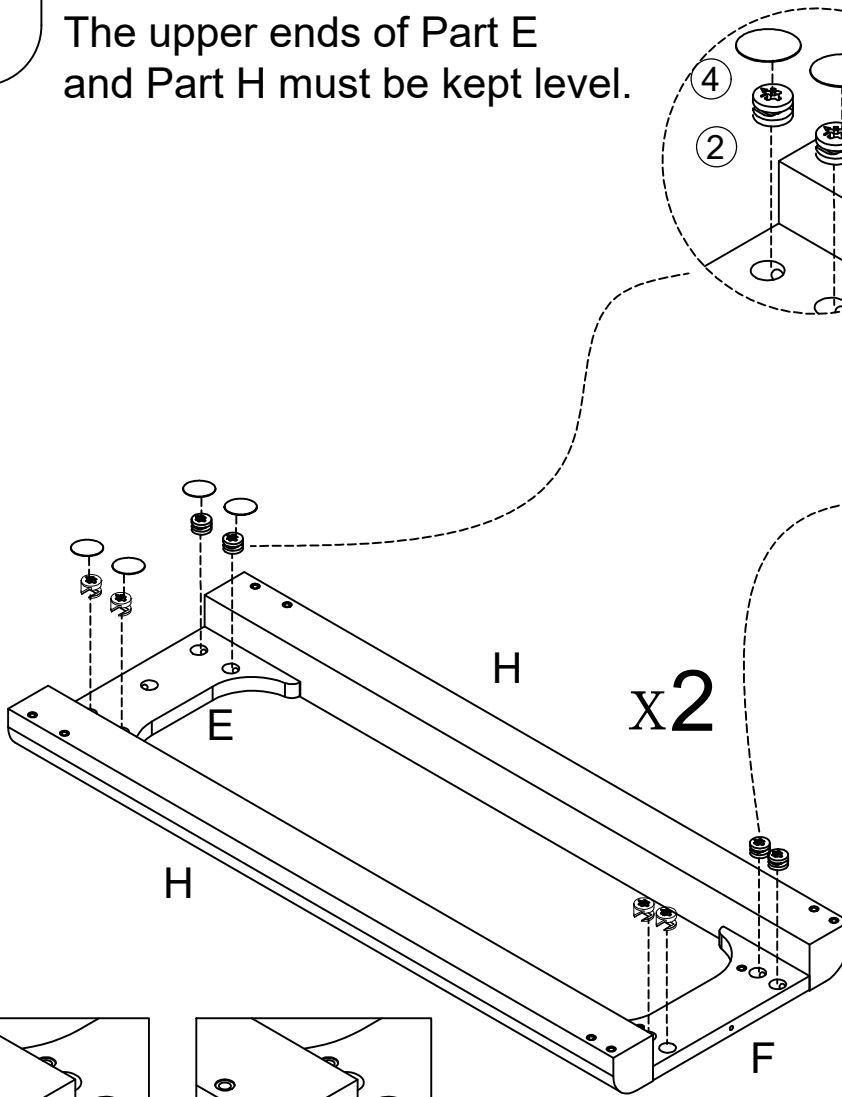

3

The upper ends of Part E and Part H must be kept level.

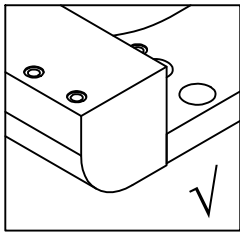
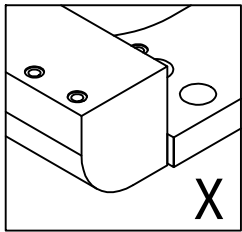

The upper ends of Part F and Part H must be kept level.



②		16PCS
④		8PCS

4

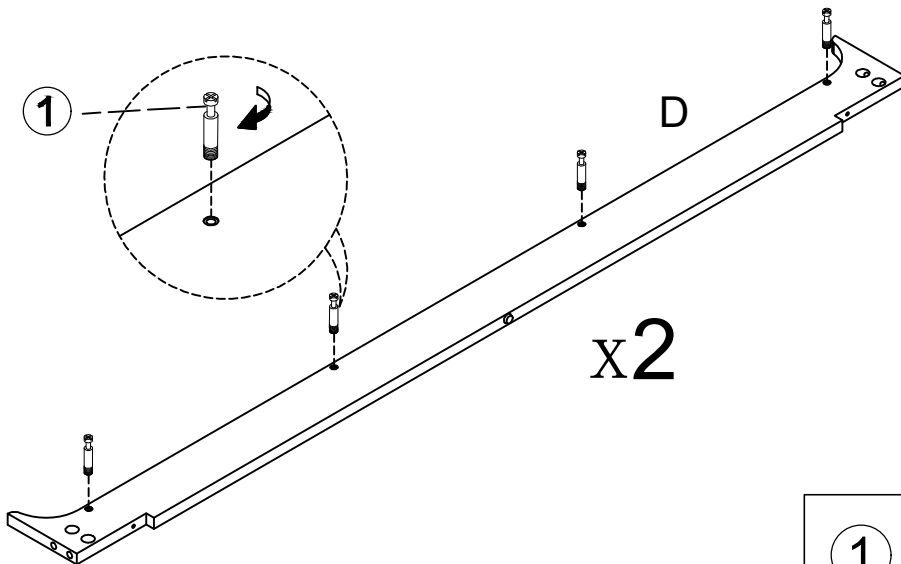

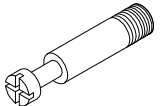
①		8PCS
---	---	------

# Assemble steps

5

The upper ends of Part D and Part B must be kept level.

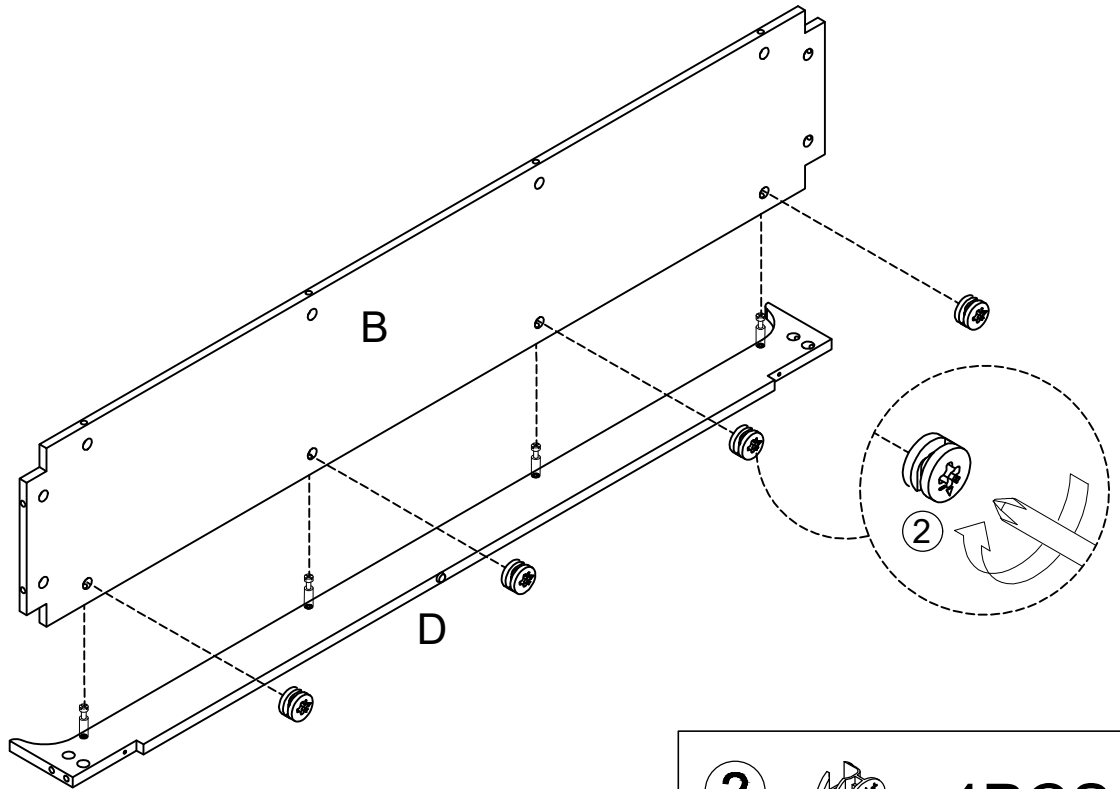
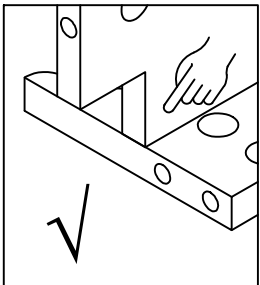
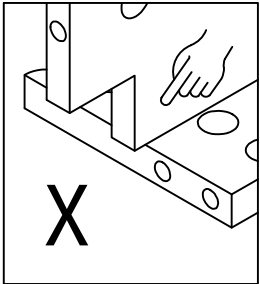

2



4PCS

6

The upper ends of Part D and Part B must be kept level.

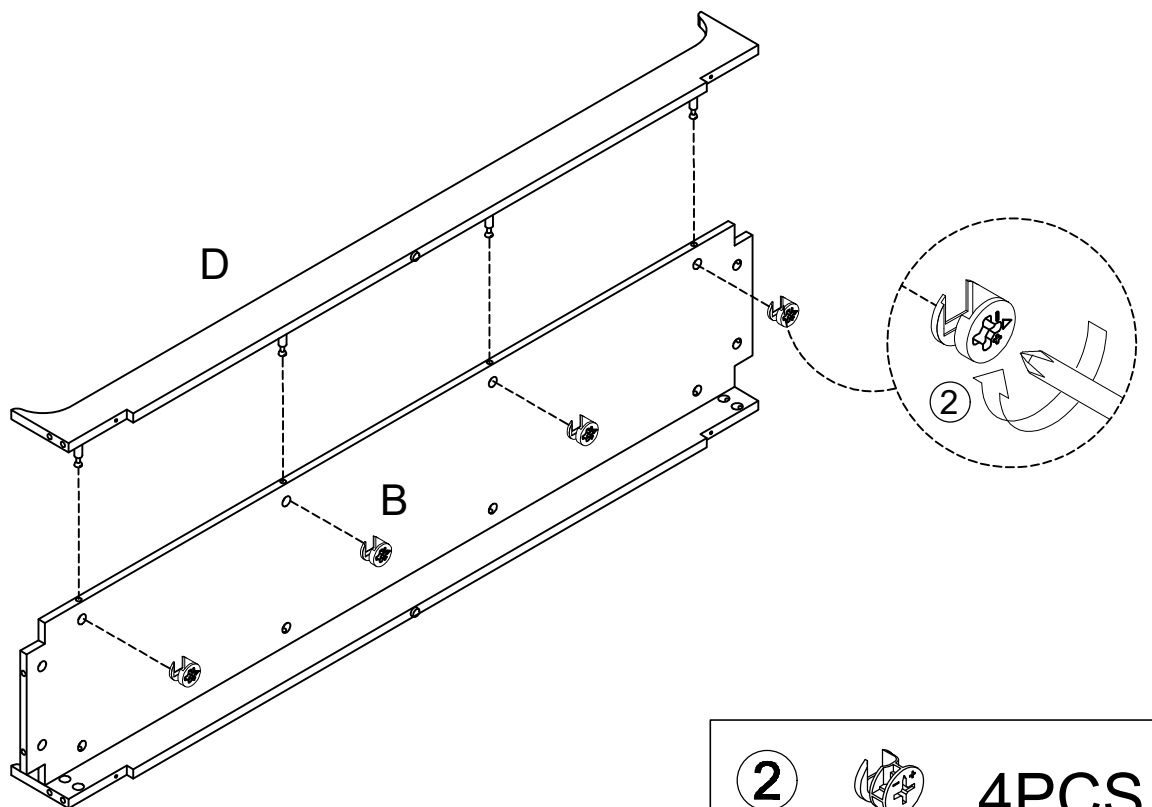
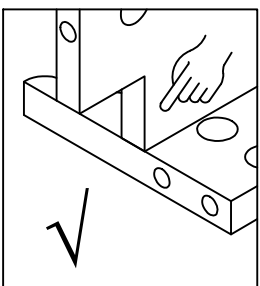
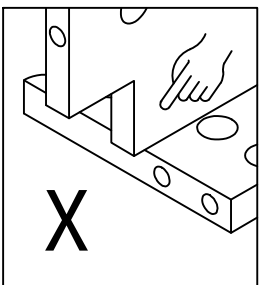

2



4PCS

# Assemble steps

7

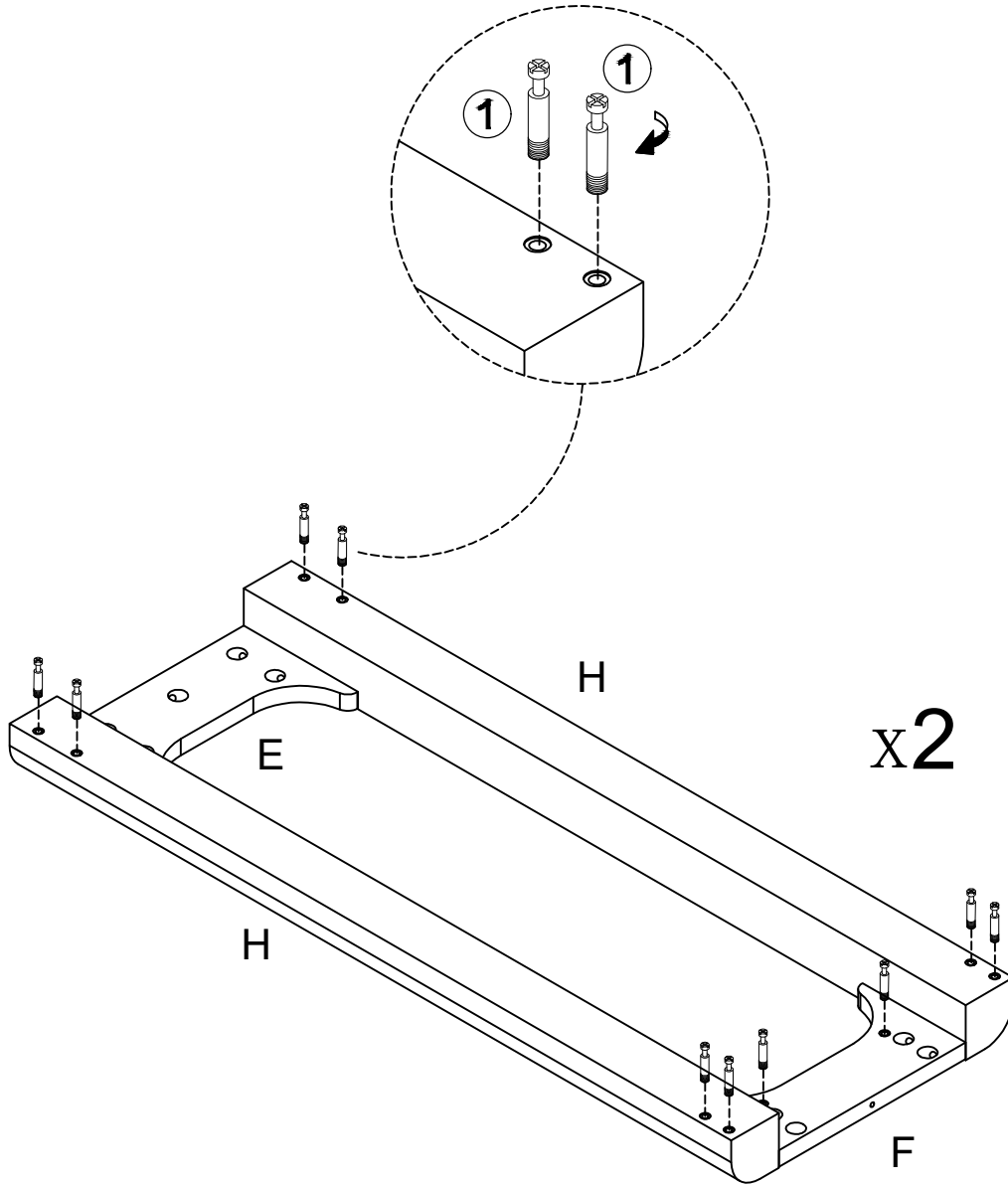

x2

1

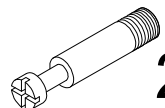

20PCS

# Assemble steps

8

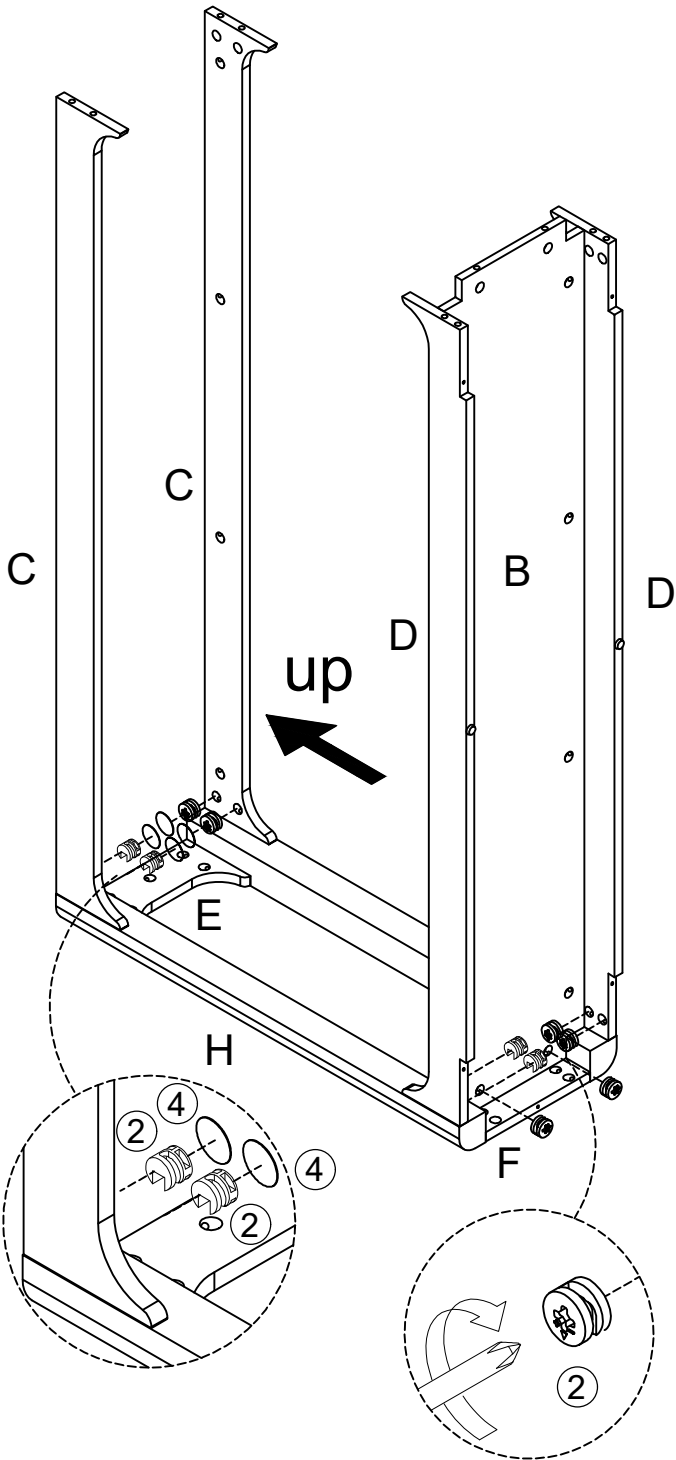

②  10PCS

④  4PCS

9

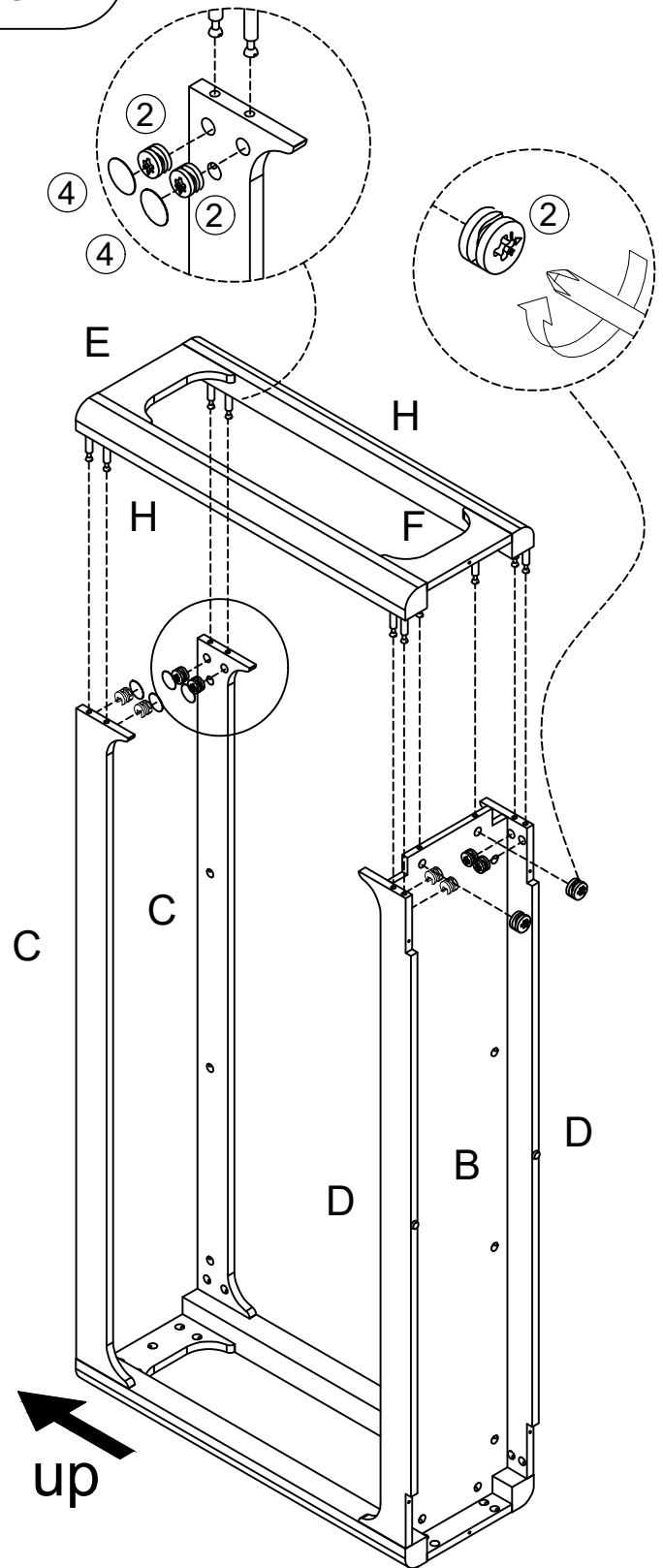

②  10PCS

④  4PCS

# Assemble steps

10

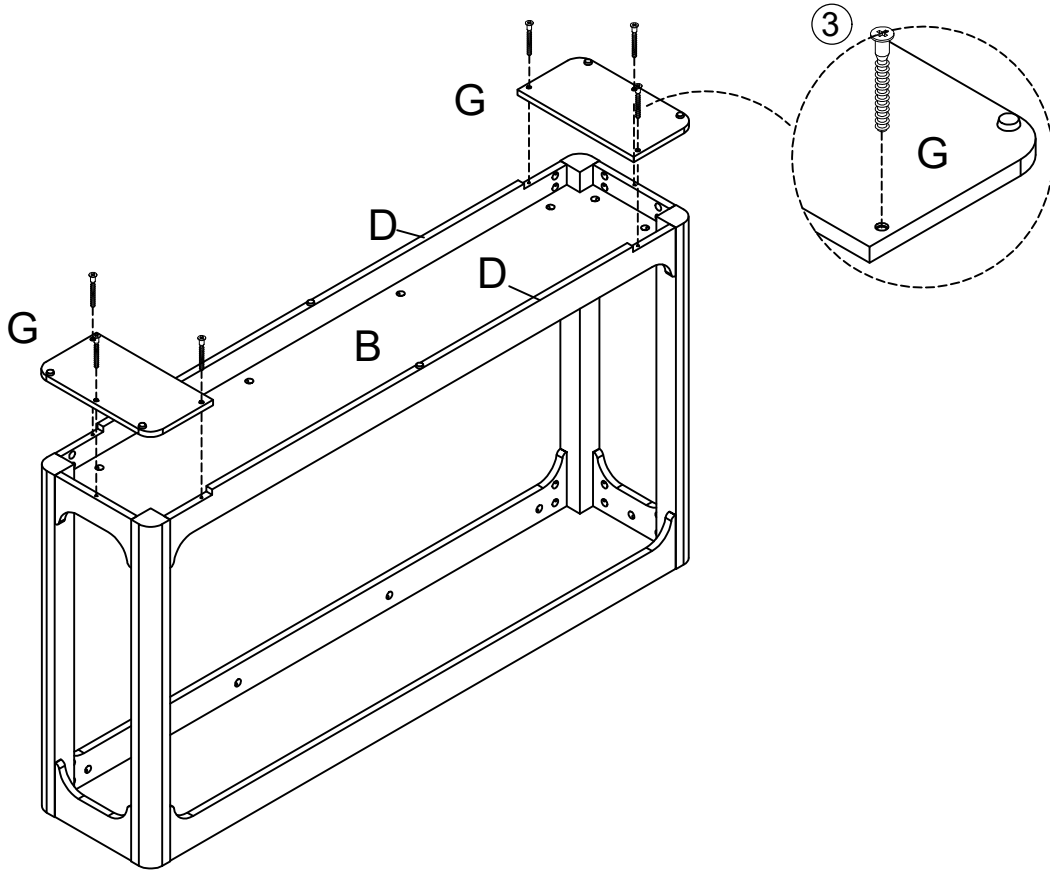

3

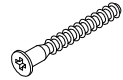

6PCS

11

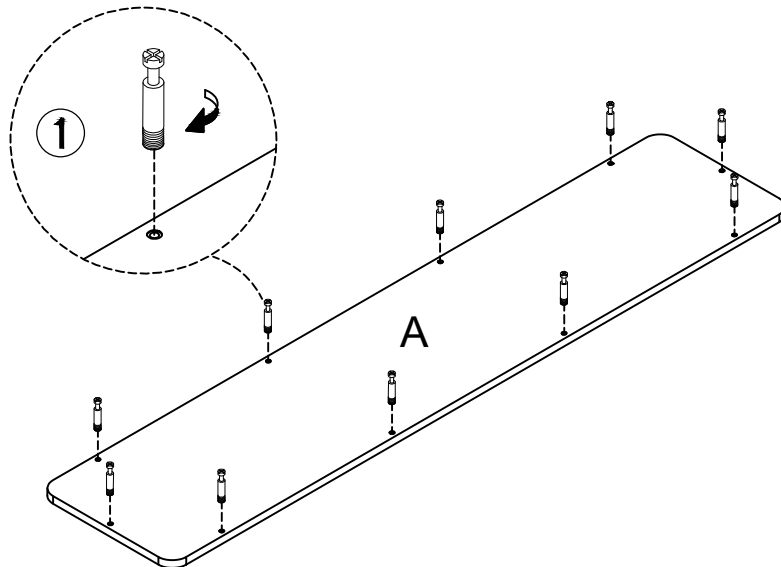

1

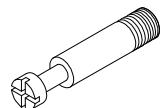

10PCS

# Assemble steps

12

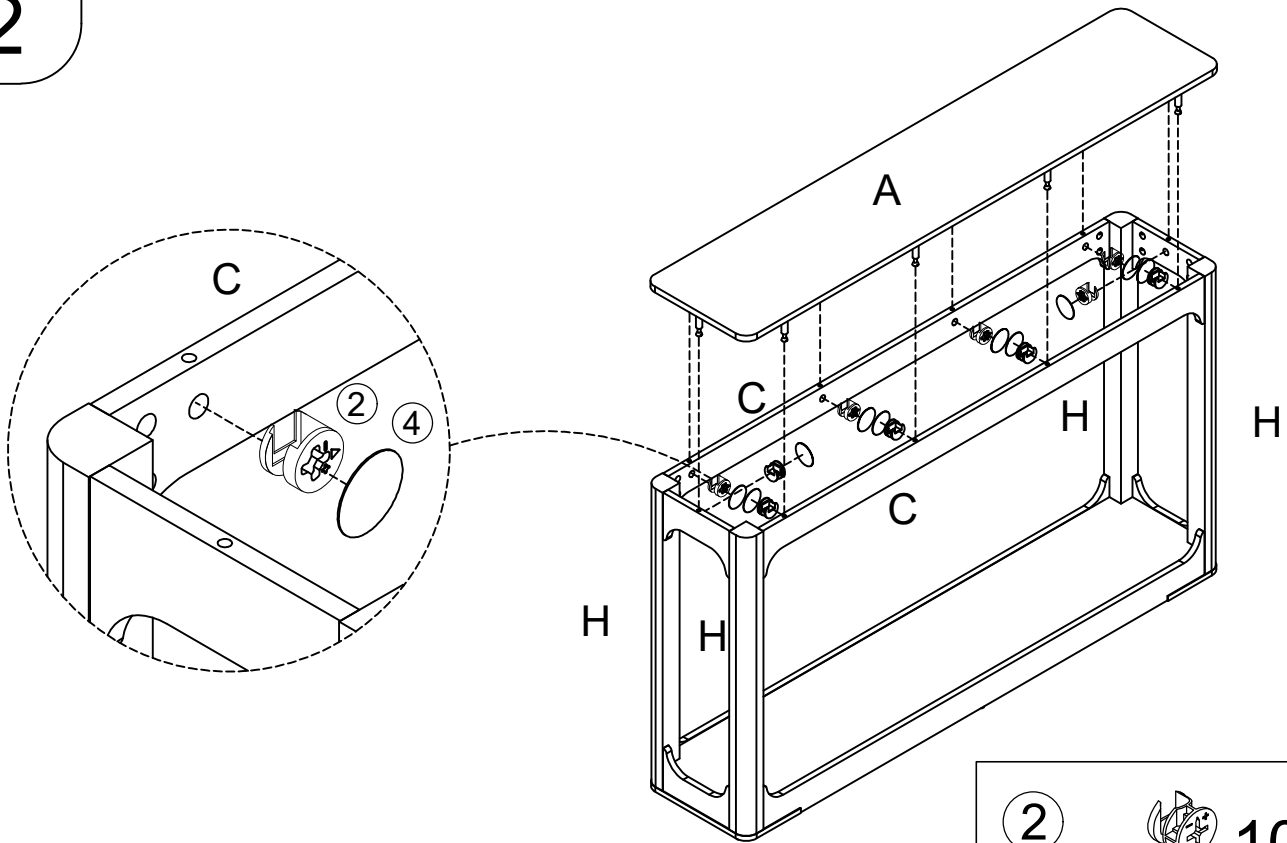

②  10PCS

④  10PCS

13

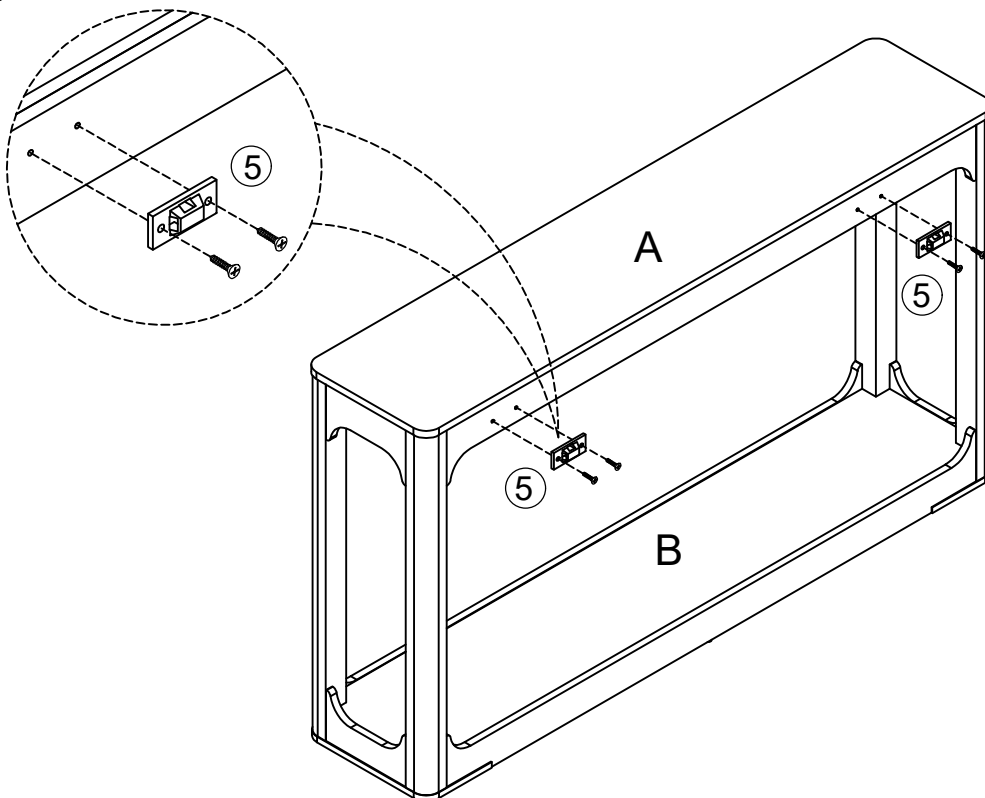

# Assemble steps

14

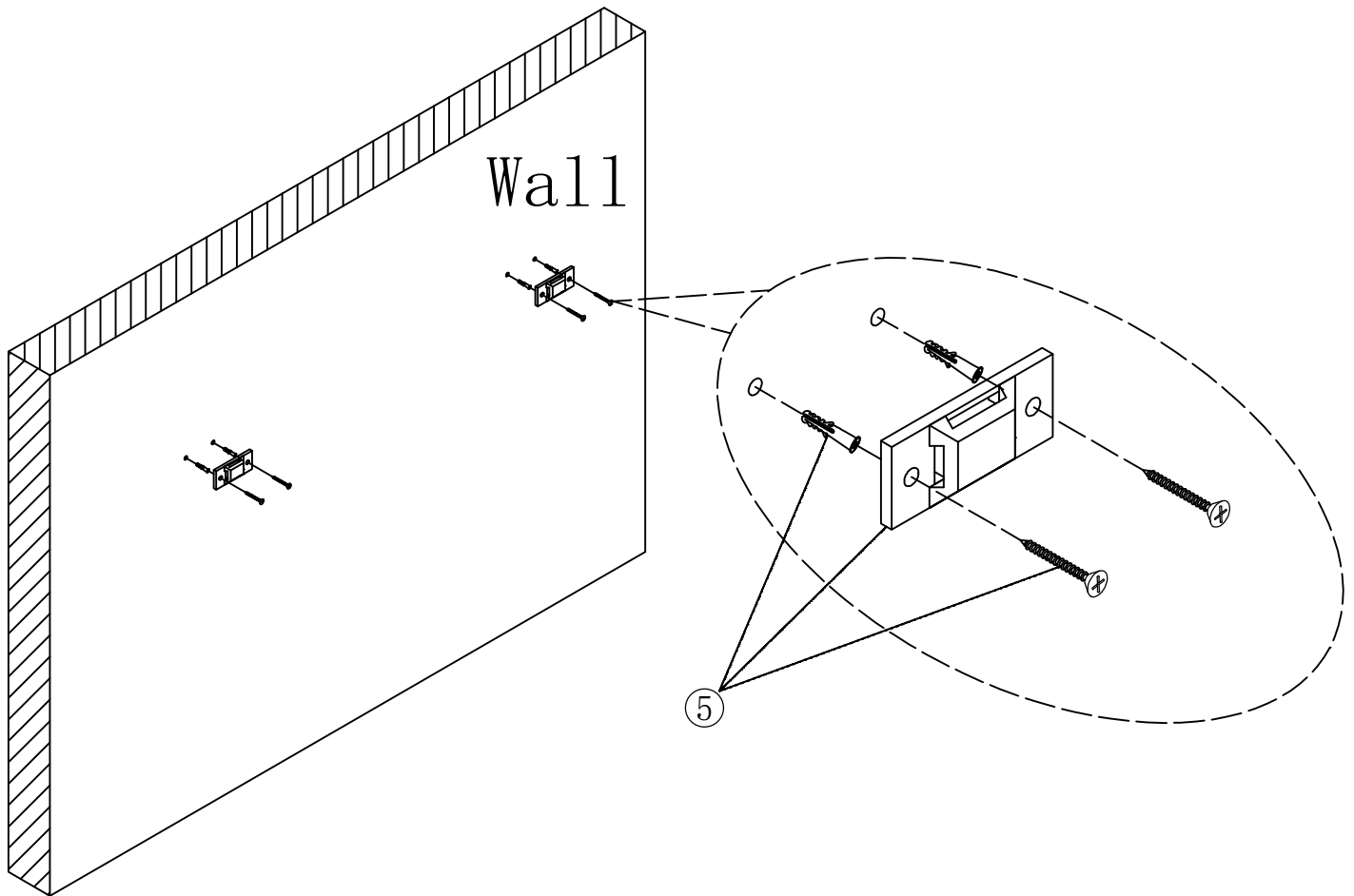

 5 x2set

# Assemble steps

15

Final

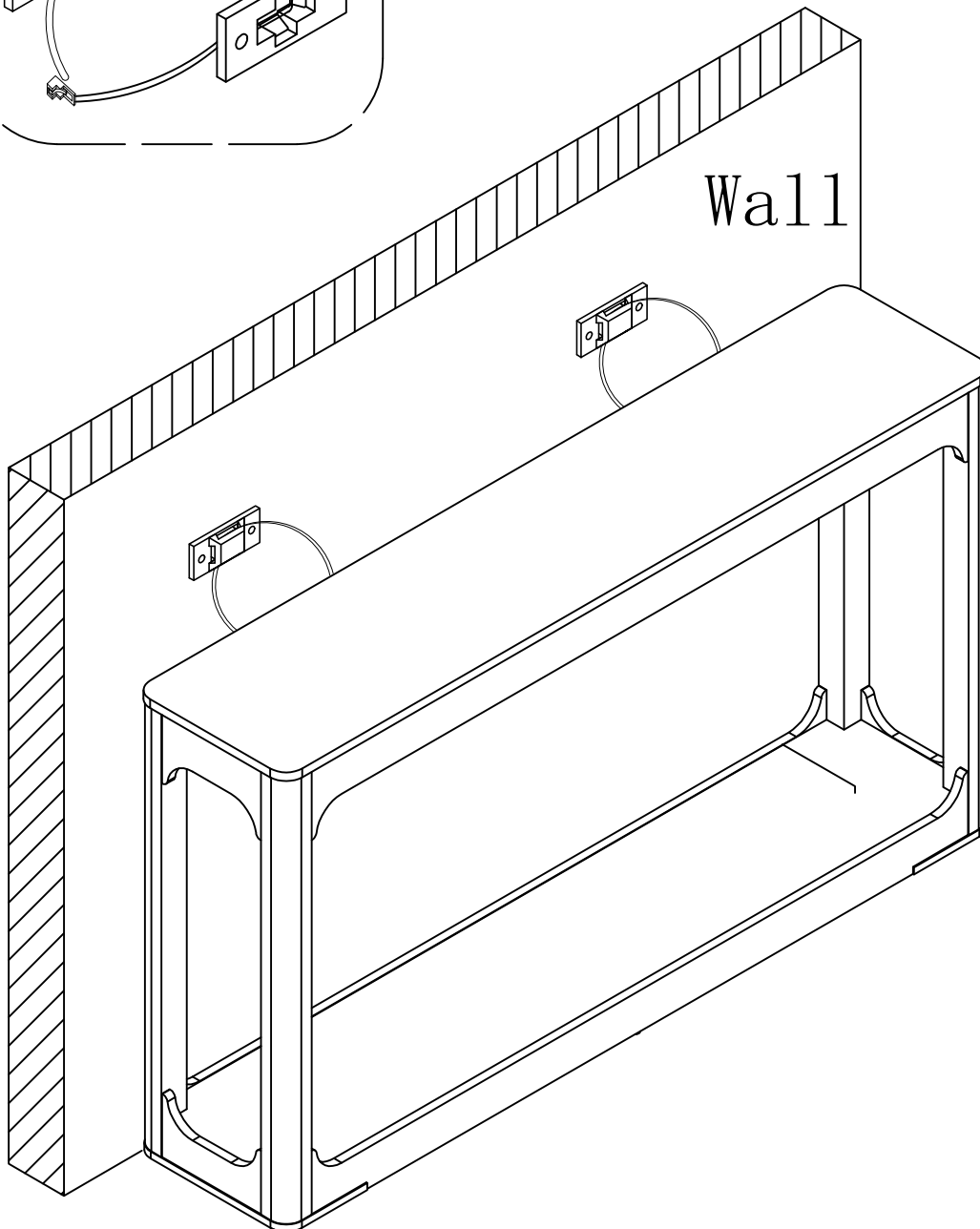
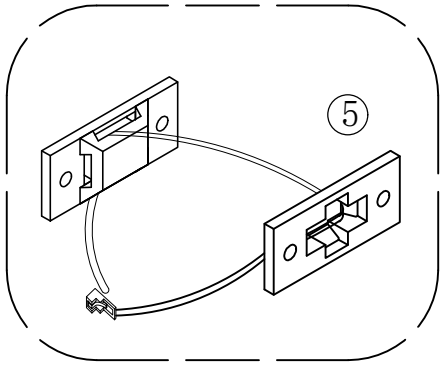

 ⑤ x2set