

ASSEMBLY INSTRUCTIONS

INSTRUCTIONS DE MONTAGE

TWIN TWIN BUNK BED WITH 2 DRAWERS

LIT SIMPLE SUPERPOSÉ AVEC 2 TIROIRS

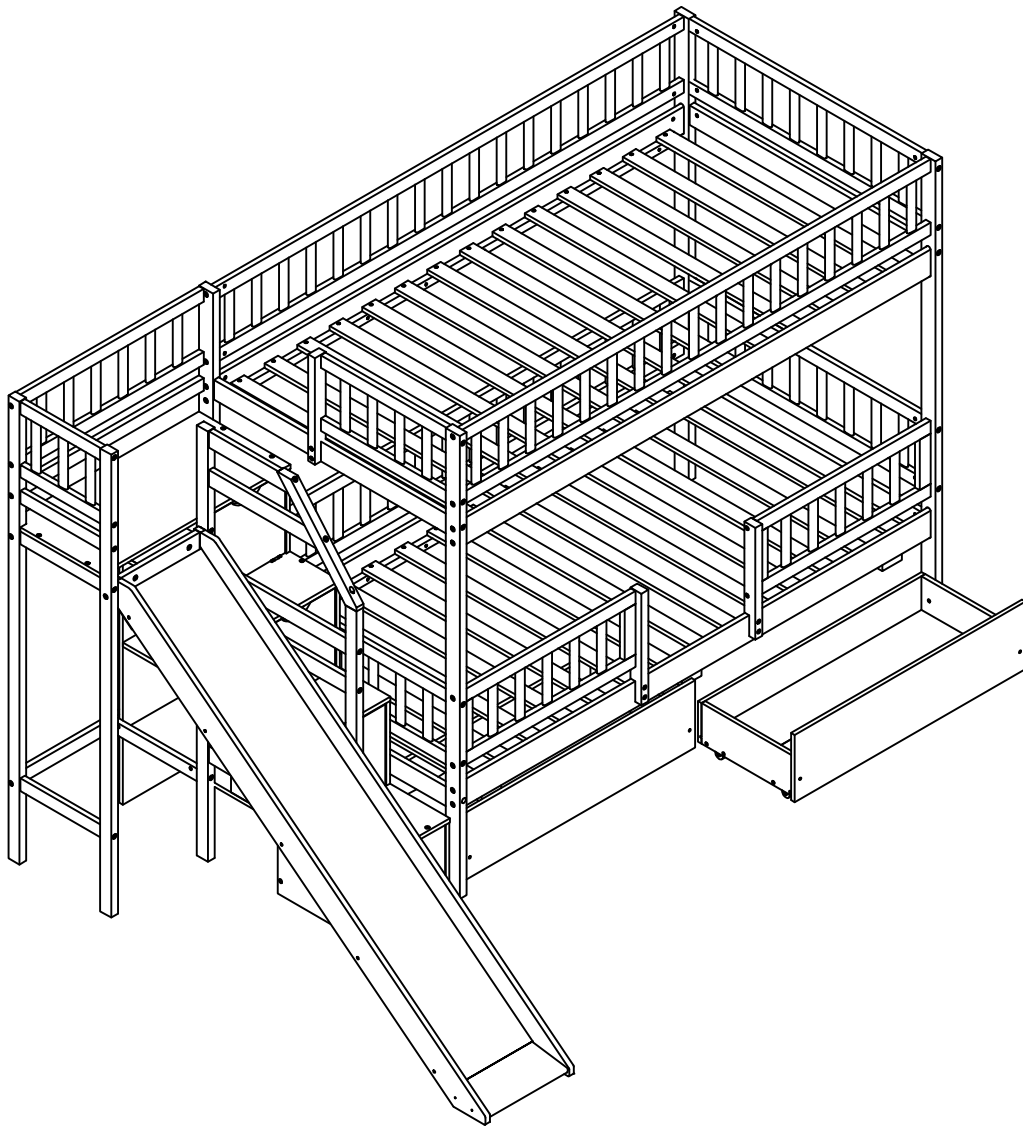

SAFETY WARNINGS AND GENERAL NOTES:

Follow the information on the warnings on the bunk bed end structure and on the carton. Do not remove the warning label from the bed. Always use the recommended size mattress on mattress support, or both, to help prevent the likelihood of entrapment or falls.

The top surface of the mattress must be at least 5*inch (127mm) below the upper edge of the guardrail.

Do not allow children under 6 years of age to use the upper bunk.

Periodically check and ensure the guardrail, ladder and other components are in their proper position, free from damage, and all connectors are tight.

Do not allow horseplay on or under beds.

Always prohibit jumping on the bed.

Prohibit more than one person on upper bunk.

Always use the ladder for entering and leaving the upper bunk.

Do not use substitute parts. Contact the manufacturer or dealer for replacement parts.

Use of a night-light may provide added safety precaution for a child using the upper bunk.

Always use guardrails on both long sides of the upper bunk.

If the bunk bed will be placed next to a wall, the guardrail that runs the full length of the bed should be placed against the wall to prevent entrapment between the bed and the wall.

The use of water or sleep flotation mattresses is prohibited.

STRANGULATION HAZARD-Never attach or hang items to any part of the bunk bed that are not designed for use with the bed.

Keep these instructions for future reference.

We recommend assembling your bunk bed on the shipping carton to protect your floor or carpet.

Be certain all staples are out of the box before beginning assembly on the shipping carton.

THIS BED IS DESIGNED TO USE A TWIN MATTRESSES 38 1/2" WIDE X 74"-75" LONG WITH THE TOTAL THICKNESS NOT EXCEEDING 6" FOR UPPER BUNK, FOR THE LOWER TWINL-SIZE SHOULD BE 38 1/2" WIDE X 74"-75" LONG, WITH 6" THICKNESS.

SURFACE OF MATTRESS MUST BE AT LEAST 5" (127MM) BELOW THE UPPER EDGE OF GUARDRAILS.

Replacement Parts:

Replacement Parts, including additional guardrails, may be obtained from any of our dealers.

AVERTISSEMENTS DE SÉCURITÉ ET REMARQUES GÉNÉRALES :

Suivez les informations sur les avertissements figurant sur la structure d'extrémité du lit superposé et sur le carton. Ne retirez pas l'étiquette d'avertissement du lit. Utilisez toujours le matelas de taille recommandée sur le support de matelas, ou les deux, pour éviter tout risque de coincement ou de chute.

La surface supérieure du matelas doit être à au moins 5*poûces (127 mm) sous le bord supérieur du garde-corps.

Ne laissez pas les enfants de moins de 6 ans utiliser le lit supérieur.

Vérifiez périodiquement et assurez-vous que le garde-corps, l'échelle et les autres composants sont dans leur bonne position, exempts de dommages et que tous les connecteurs sont bien serrés.

Ne permettez pas les chahuts sur ou sous les lits.

Interdisez toujours de sauter sur le lit.

Interdire plus d'une personne sur la couchette supérieure.

Utilisez toujours l'échelle pour entrer et sortir du lit supérieur.

N'utilisez pas de pièces de rechange. Contactez le fabricant ou le revendeur pour obtenir des pièces de rechange.

L'utilisation d'une veilleuse peut fournir une précaution supplémentaire en matière de sécurité pour un enfant utilisant le lit supérieur.

Utilisez toujours des garde-corps sur les deux côtés longs du lit supérieur.

Si le lit superposé doit être placé à côté d'un mur, le garde-corps qui s'étend sur toute la longueur du lit doit être placé contre le mur pour éviter tout coincement entre le lit et le mur.

L'utilisation de matelas flottants à eau ou de sommeil est interdite.

RISQUE D'ÉTRANGULATION - N'attachez ou ne suspendez jamais d'objets à une partie du lit superposé qui ne sont pas conçus pour être utilisés avec le lit.

Conservez ces instructions pour référence future.

Nous vous recommandons d'assembler votre lit superposé sur le carton d'expédition pour protéger votre sol ou votre tapis.

Assurez-vous que toutes les agrafes sont sorties de la boîte avant de commencer l'assemblage sur le carton d'expédition.

CE LIT EST CONÇU POUR UTILISER UN MATELAS JUMEAUX DE 38 1/2" DE LARGE X 74" - 75" DE LONG AVEC L'ÉPAISSEUR TOTALE NE DÉPASSANT PAS 6" POUR LE COUCHE SUPÉRIEUR, POUR LE JUMEL INFÉRIEUR, LA TAILLE DOIT ÊTRE DE 38 1/2" DE LARGE X 74 "-75" DE LONG, LARGE AVEC 6" D'ÉPAISSEUR.

LA SURFACE DU MATELAS DOIT ÊTRE AU MOINS 5" (127 MM) EN DESSOUS DU BORD SUPÉRIEUR DES GARDE-CORPS.

Pièces de rechange :

Les pièces de rechange, y compris les garde-corps supplémentaires, peuvent être obtenues auprès de l'un de nos revendeurs).



SAFETY WARNING



1. At the beginning :
 - Tighten all hardware.
 - Check metal parts for rust. If found, sand and repaint using a non-lead-based paint meeting the requirements of 16 CFR 1303.
 - Check all wood members for deterioration and splinters. Sand down splinters and replace deteriorating wood members.
 - Rake and check depth of loose fill protective surfacing materials to prevent compaction and to maintain appropriate depth. Replace as necessary.
2. Twice a month :
 - Tighten all hardware.
 - Rake and check depth of loose fill protective surfacing materials to prevent compaction and to maintain appropriate depth. Replace as necessary.
3. Owners shall be responsible for maintaining the legibility of the warning labels.
4. Disposal Instructions
 - There shall be instructions advising the owner to disassemble and dispose of the playground equipment in such a way that no unreasonable hazards will exist at the time the playground equipment is discarded.
5. The instruction shall also include the information found in Section 4 of the United States Consumer Product Safety Commission's (USCPSC) Outdoor Home Playground Safety Handbook or specific surfacing guidelines for the product consistent with the USCPSC Handbook. A copy of this section may be found in Appendix X2.
6. Observing the following statements and warnings reduces the like lihood of serious or fatal injury.
7. Specifying the number and weight of occupants that may safely use the equipment singly or simultaneously.
8. Recommending on-site adult supervision for children of all ages.
9. Warning the owner to instruct children not to use the equipment in a manner other than intended.
10. Warning the owner to instruct children not to get off equipment while it is in motion.
11. Warning the owner to allow children to wear inappropriate items, such as but not limited to, loose fitting clothing, hood and neck drawstrings, scarves, cord-connected items, capes and ponchos. These items can cause death by strangulation.
12. Warning the owner to instruct children not to climb when the equipment is wet.
13. Warning the owner to instruct children not to attach items to the playground equipment that are not specifically designed for use with the equipment, such as, but not limited to, jump ropes, clothesline, pet leashes, cables and chain as they may cause a strangulation hazard.
14. Warning the owner to instruct children to remove their bike or other sports helmet before playing on the playground equipment.
15. Warning the owner to dress children with well-fitting and full foot enclosing footwear. Examples of inappropriate footwear are clogs, flip flops, and sandals.
16. Place the equipment on level ground, not less than 6 ft (1.8 m) from any structure or obstruction such as a fence, garage, house, overhanging branches, laundry lines, or electrical wires.
17. Do not install home playground equipment over concrete, asphalt, packed earth, grass, carpet, or any other hard surface. A fall onto a hard surface can result in serious injury or death to the equipment user
18. To prevent serious injury, cautionary statements shall be included which warn that children must not use the equipment until properly installed.



AVERTISSEMENTS DE SÉCURITÉ



1. Au début:

Serrez tout le matériel.

Vérifiez les pièces métalliques pour la rouille. Si vous en trouvez, poncez et repeignez à l'aide d'une peinture sans plomb aux exigences du 16 CFR 1303.

Vérifiez tous les éléments en bois pour déceler toute détérioration et éclats. Poncez vers le bas éclats et remplacez éléments en bois détériorés.

Ratisser et vérifier la profondeur des matériaux de revêtement de protection en vrac pour éviter le compactage et pour maintenir une profondeur appropriée. Remplacez si nécessaire.

2. Deux fois par mois :

Serrez tout le matériel.

Ratisser et vérifier la profondeur des matériaux de revêtement de protection en vrac pour éviter le compactage et pour maintenir une profondeur appropriée. Remplacez si nécessaire.

3. Les propriétaires sont responsables du maintien de la lisibilité des étiquettes d'avertissement.

4. Instructions d'élimination

Il doit y avoir des instructions conseillant au propriétaire de démonter et de jeter l'équipement de terrain de jeu dans de telle manière qu'aucun danger déraisonnable n'existe au moment où l'équipement de terrain de jeu est mis au rebut.

5. L'instruction doit également inclure les informations contenues dans la section 4 du United States Consumer Product

Manuel de sécurité des aires de jeux extérieures de la Commission de sécurité (USCPSC) ou revêtement spécifique directives pour le produit conformes au manuel USCPSC. Une copie de cette section peut être trouvée dans Annexe X2.

6. Le respect des déclarations et avertissements suivants réduit le risque de blessures graves, voire mortelles.

7. Préciser le nombre et le poids des occupants pouvant utiliser l'équipement en toute sécurité, seuls ou simultanément.

8. Nous recommandons la surveillance d'un adulte sur place pour les enfants de tous âges.

9. Avertissez le propriétaire de demander aux enfants de ne pas utiliser l'équipement d'une manière autre que celle prévue.

10. Avertissez le propriétaire de demander aux enfants de ne pas descendre de l'équipement lorsqu'il est en mouvement.

11. Avertir le propriétaire de permettre aux enfants de porter des articles inappropriés, tels que, sans toutefois s'y limiter, des vêtements amples, vêtements, cordons de capuche et de cou, foulards, articles reliés par cordon, capes et ponchos. Ces objets peuvent provoquer la mort par strangulation.

12. Avertir le propriétaire de demander aux enfants de ne pas grimper lorsque l'équipement est mouillé.

13. Avertir le propriétaire de demander aux enfants de ne pas attacher d'objets à l'équipement de jeu qui ne sont pas spécialement conçu pour être utilisé avec l'équipement, tel que, sans toutefois s'y limiter, des cordes à sauter, une corde à linge, un animal de compagnie laissés, câbles et chaînes car ils peuvent présenter un risque d'étranglement.

14. Avertir le propriétaire de demander aux enfants de retirer leur vélo ou autre casque de sport avant de jouer sur le équipement de terrain de jeu.

15. Avertir le propriétaire d'habiller les enfants avec des chaussures bien ajustées et couvrant tout le pied. Exemples de les chaussures inappropriées sont les sabots, les tongs et les sandales.

16. Placez l'équipement sur un sol plat, à au moins 6 pieds (1,8 m) de toute structure ou obstacle tel qu'un clôture, garage, maison, branches en surplomb, cordes à linge ou fils électriques.

17. N'installez pas d'équipement de terrain de jeu domestique sur du béton, de l'asphalte, de la terre battue, de l'herbe, de la moquette ou tout autre surface dure. Une chute sur une surface dure peut entraîner des blessures graves, voire la mort de l'utilisateur de l'équipement.

18. Pour éviter des blessures graves, des mises en garde doivent être incluses pour avertir que les enfants ne doivent pas utiliser le l'équipement jusqu'à ce qu'il soit correctement installé.





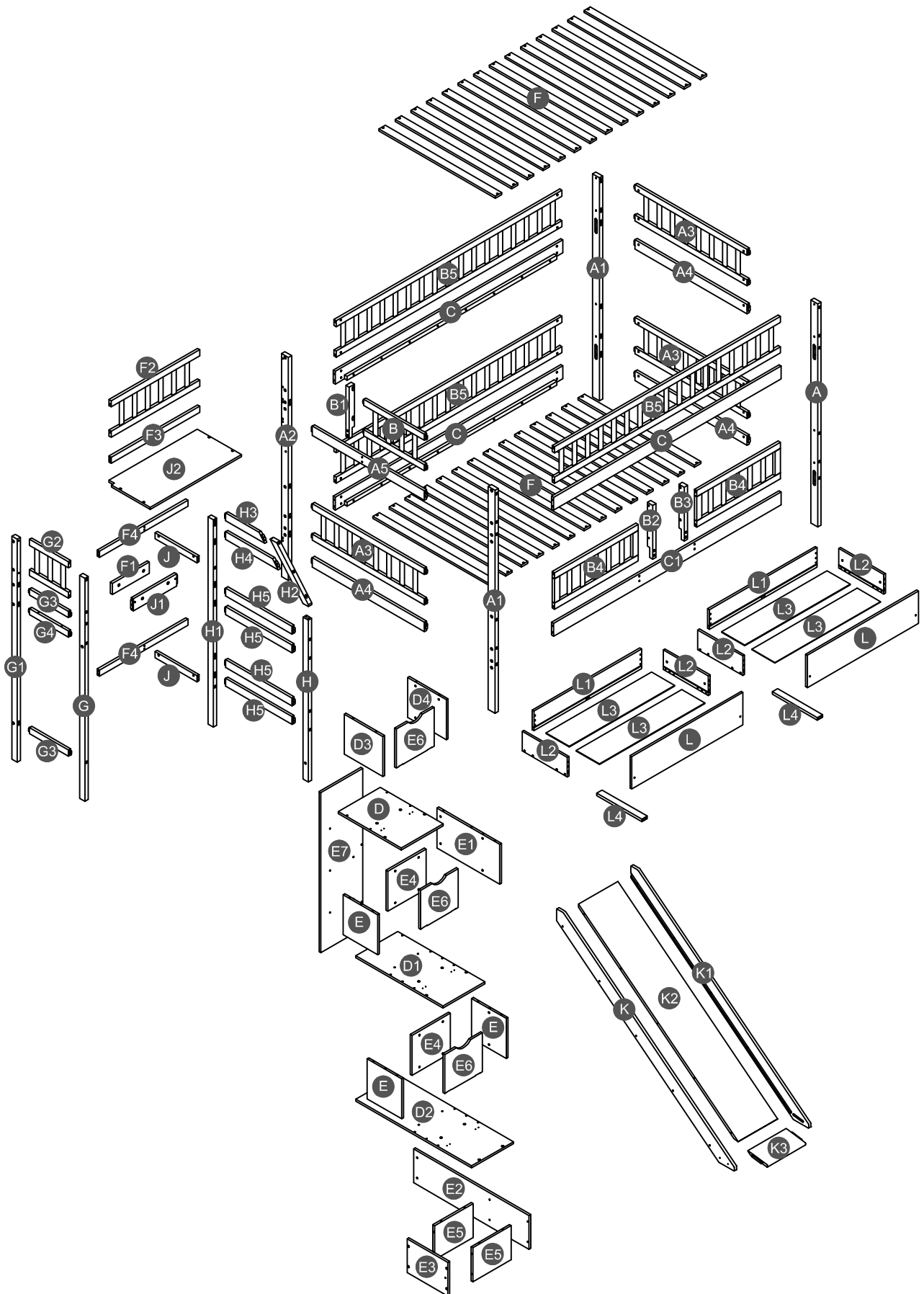



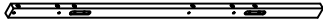
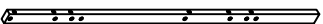
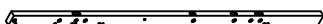
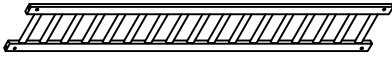

Detail View

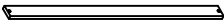
Vue Détaillée

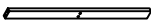
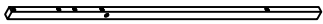
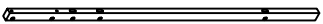
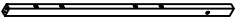
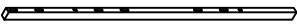









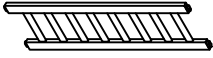
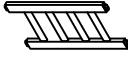

Part list (Box 1)

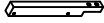
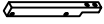
Liste des pièces (Boîte 1)

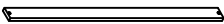
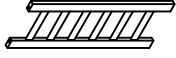
<p>A</p>  <p>Leg (right front) - 1pc Pied (Avant droit)</p>	<p>A1</p>  <p>Leg (left front/right back) - 2pcs Pied (avant gauche/arrière droit)</p>	<p>A2</p>  <p>Leg (left back) - 1pc Pied (Arrière gauche)</p>
<p>B5</p>  <p>Guard rail - 3pcs Garde-corps</p>	<p>C</p>  <p>Side rail - 3pcs Rail latéral supérieur</p>	<p>C1</p>  <p>Lower side rail (front) - 1pc Rail latéral inférieur (avant)</p>
<p>F</p>  <p>Slats - 14pcs Lattes</p>	<p>F3</p>  <p>Upper horizontal bar (back) - 1pc Barre horizontale supérieure (arrière)</p>	<p>F4</p>  <p>Lower horizontal bar (back) - 2pcs Barre horizontale inférieure (arrière)</p>
<p>G</p>  <p>Vertical bar (front)- 1pc Barre verticale (avant)</p>	<p>G1</p>  <p>Vertical bar (back)- 1pc Barre verticale (arrière)</p>	<p>H</p>  <p>Vertical bar (front)- 1pc Barre verticale (avant)</p>
<p>H1</p>  <p>Vertical bar (back)- 1pc Barre verticale (arrière)</p>	<p>H2</p>  <p>Horizontal bar (front) - 1pc Barre horizontale (avant)</p>	<p>H3</p>  <p>Upper horizontal bar - 1pc Barre horizontale supérieure</p>
<p>H4</p>  <p>Divider horizontal bar - 1pc Barre de séparation horizontale</p>	<p>K</p>  <p>Left side ladder -1pc Échelle côté gauche</p>	<p>K1</p>  <p>Right side ladder -1pc Échelle côté droit</p>

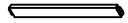

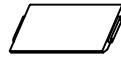
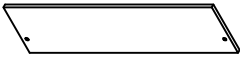

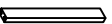





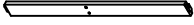





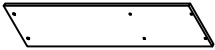

Part list & Hardware list (Box 2)

Liste des pièces & liste du matériel (Boîte 2)

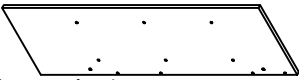
<p>A3</p>  <p>Frame HB/FB - 3pcs Cadre HB/FB</p>	<p>B</p>  <p>Frame FB - 1pc Cadre FB</p>	<p>B1</p>  <p>Vertical guard rail FB - 1pc Garde-corps vertical FB</p>
<p>B2</p>  <p>Vertical guard rail (left) - 1pc Garde-corps vertical (gauche)</p>	<p>B3</p>  <p>Vertical guard rail (right) - 1pc Garde-corps vertical (droit)</p>	<p>B4</p>  <p>Guard rail (front) - 2pcs Garde-corps (avant)</p>
<p>F</p>  <p>Slats - 14pcs Lattes</p>	<p>F2</p>  <p>Guard rail (back) - 1pc Garde-corps (arrière)</p>	<p>G2</p>  <p>Guard rail (left) - 1pc Garde-corps (gauche)</p>
<p>H5</p>  <p>Lower horizontal bar - 4pcs Barre horizontale inférieure</p>	<p>K2</p>  <p>Slide panel -1pc Panneau coulissant</p>	<p>K3</p>  <p>Slide base support -1pc Support de base coulissante</p>
<p>L</p>  <p>Front drawer panel - 2pcs Panneau de tiroir avant</p>	<p>L1</p>  <p>Back drawer panel - 2pcs Panneau de tiroir arrière</p>	<p>L2</p>  <p>Left / right drawer panel - 4pcs Panneau de tiroir gauche/droit</p>
<p>L4</p>  <p>Support drawer - 2pcs Tiroir support</p>		

Part list (Box 3)

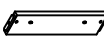
Liste des pièces (Boîte 3)

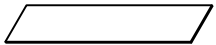

<p>A4</p>  <p>Horizontal bar HB/FB - 3pcs Barre horizontale HB/FB</p>	<p>A5</p>  <p>Upper horizontal bar FB - 1pc Barre horizontale supérieure FB</p>	<p>D</p>  <p>Upper center step ladder panel -1pc Panneau d'échelle central supérieur</p>
<p>D1</p>  <p>Center step ladder panel -1pc Panneau d'échelle à marchepied central</p>	<p>D2</p>  <p>Lower step ladder panel -1pc Panneau d'échelle inférieure</p>	<p>D3</p>  <p>Upper left side panel - 1pc Panneau latéral supérieur gauche</p>
<p>D4</p>  <p>Upper right side panel - 1pc Panneau latéral supérieur droit</p>	<p>E</p>  <p>Center side panel - 3pcs Panneau latéral central</p>	<p>E1</p>  <p>Upper center right side panel - 1pc Panneau latéral supérieur central droit</p>
<p>E2</p>  <p>Lower right side panel - 1pc Panneau latéral inférieur droit</p>	<p>E3</p>  <p>Lower left side panel - 1pc Panneau latéral inférieur gauche</p>	<p>E4</p>  <p>Center panel - 2pcs Panneau central</p>
<p>E5</p>  <p>Lower front panel - 2pcs Panneau avant inférieur</p>	<p>E6</p>  <p>Upper front panel - 3pcs Panneau avant supérieur</p>	<p>E7</p>  <p>Back panel - 1pc Panneau arrière</p>
<p>F1</p>  <p>Support - 1pc Support</p>	<p>G3</p>  <p>Horizontal bar - 2pcs Barre horizontale</p>	<p>G4</p>  <p>Divider horizontal bar - 1pc Barre de séparation horizontale</p>
<p>J</p>  <p>Support bar - 2pcs Barre de support</p>	<p>J1</p>  <p>Support bar (front) - 1pc Barre de support (avant)</p>	<p>J2</p>  <p>Upper step ladder panel -1pc Panneau d'échelle central</p>
<p>L3</p>  <p>Drawer bottom - 4pcs Fond de tiroir</p>		

Hardware List (Box 2)

Liste du matériel (Boîte 2)

1	 Ø8*30mm	2	 Ø10*20mm	3	 (Ø15)1/4"*100mm
Wood dowel (55pcs) Cheville en bois		Wood dowel (8pcs) Cheville en bois		Hex-Head bolts (22pcs) Boulons à tête hexagonale	
4	 (Ø15)1/4"*80mm	5	 (Ø12)1/4"*70mm	6	 (Ø12)1/4"*60mm
Hex-Head bolts (48pcs) Boulons à tête hexagonale		Hex-Head bolts (16pcs) Boulons à tête hexagonale		Hex-Head bolts (52pcs) Boulons à tête hexagonale	
7	 (Ø12)1/4"*40mm	8	 (Ø12)1/4"*35mm	9	 (Ø12)1/4"*30mm
Hex-Head bolts (3pcs) Boulons à tête hexagonale		Hex-Head bolts (6pcs) Boulons à tête hexagonale		Hex-Head bolts (2pcs) Boulons à tête hexagonale	
10	 1/4"*15 (9.5mm)	11	 (Ø12)1/4"*65mm	12	 (Ø12)1/4"*50mm
Horizontal-Hole bolts(138pcs) Boulons à trou horizontal		Hex-Head bolts (1pc) Boulons à tête hexagonale		Hex-Head bolts (26pcs) Boulons à tête hexagonale	
13	 (Ø12)1/4"*40mm	14	 Ø4*30mm	15	 Ø3.5*15mm
Hex-Head bolts (2pcs) Boulons à tête hexagonale		Wood screws (82pcs) Vis		Wood screws (36pcs) Vis	
16	 42*12*1mm	17	 45*17*13mm	18	 142*18*2mm
Metal magnet (3pcs) Aimant en métal		Door catch (3pcs) Loquet de porte		Hooks (2pcs) Crochets	
19	 40*17*17*1.6mm	20	 Ø13"*3mm	21	 100*52*20 mm
Metal bracket (3pcs) Support métallique		Spring Washer (14pcs) Rondelle élastique		Wheels (8pcs) Roues	
22	 80*40*19 mm	23	 (1/4")4.5*58mm		
Drawer stopper (3pcs) Butée de tiroir		Allen key (1pc) Clé Allen			

STEP 1:
ÉTAPE

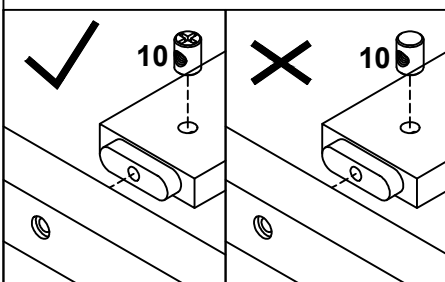
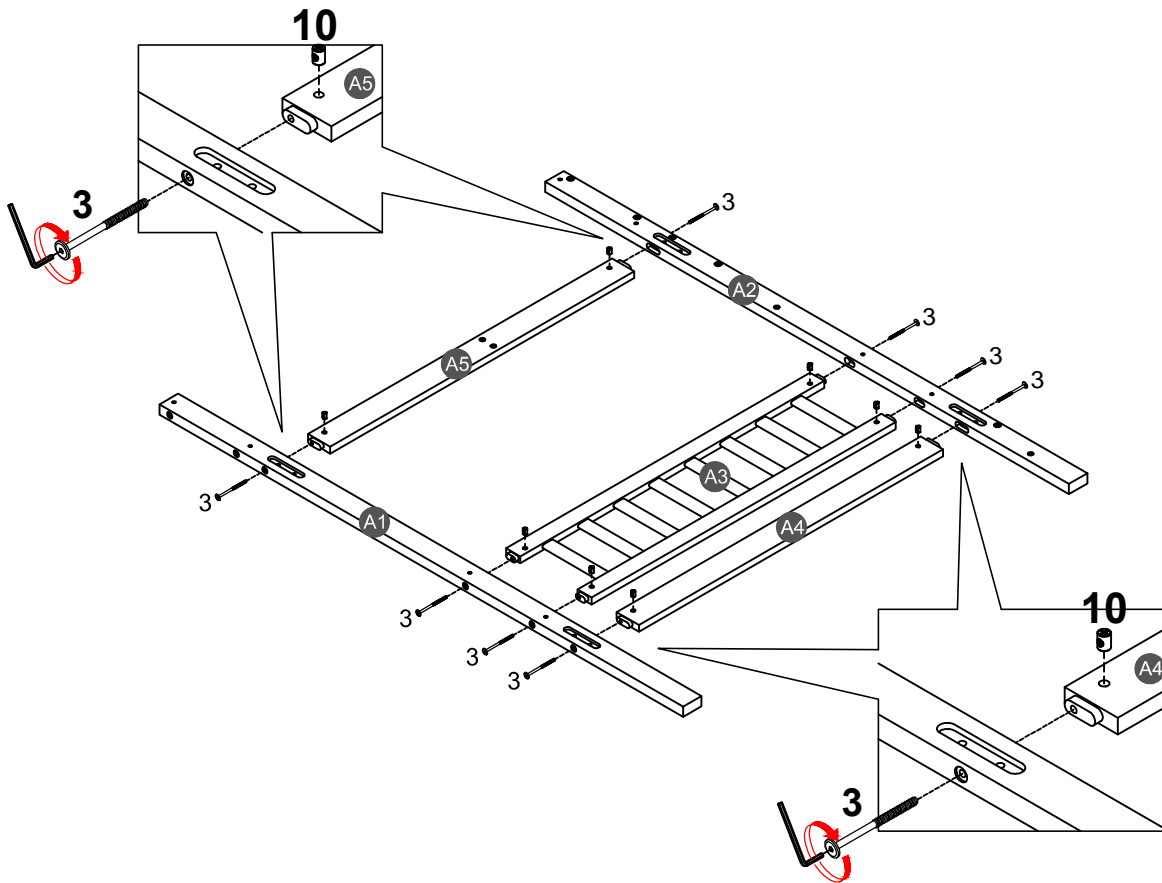

3		10	
8PCS		8PCS	



Note: Part 10 will face up with the "x" mark on it, otherwise it cannot be tightened



Remarque: La pièce 10 sera face vers le haut avec la marque "x", sinon elle ne peut pas être serrée.

STEP 2:
ÉTAPE

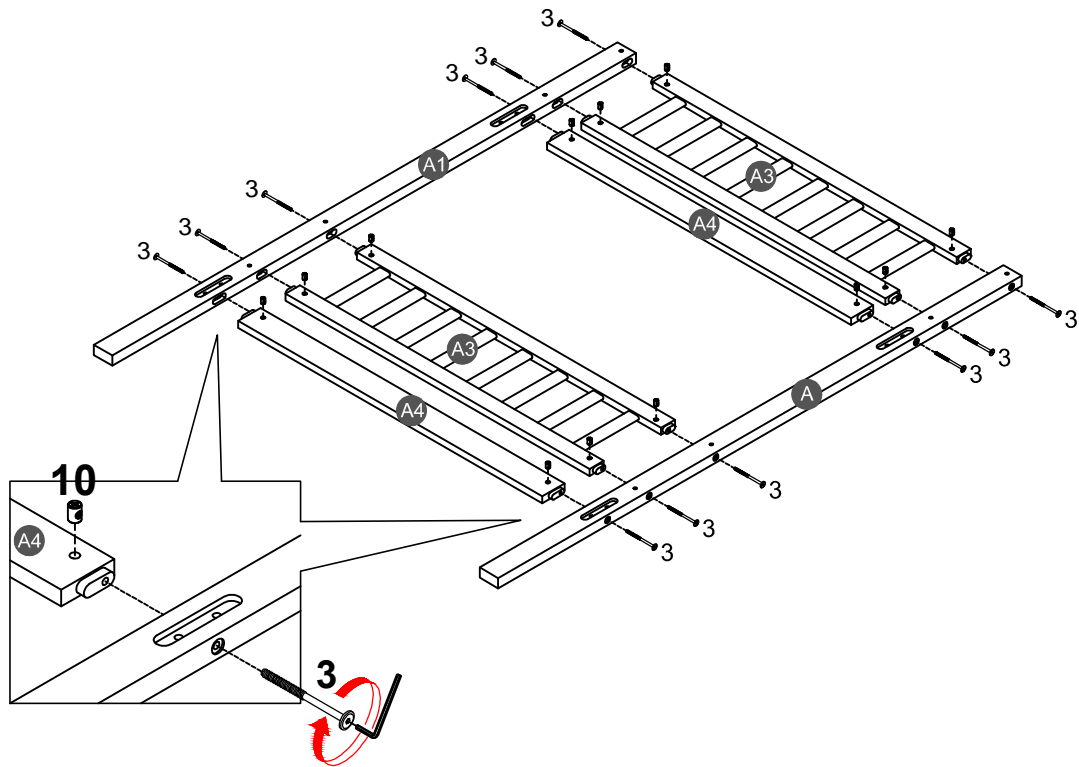
3		10	
12PCS		12PCS	



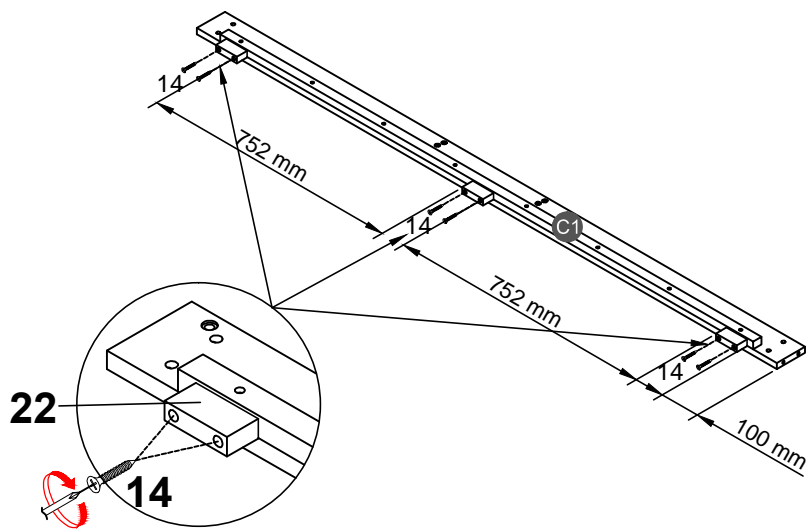

STEP 3:
ÉTAPE

14		22	
6PCS		3PCS	



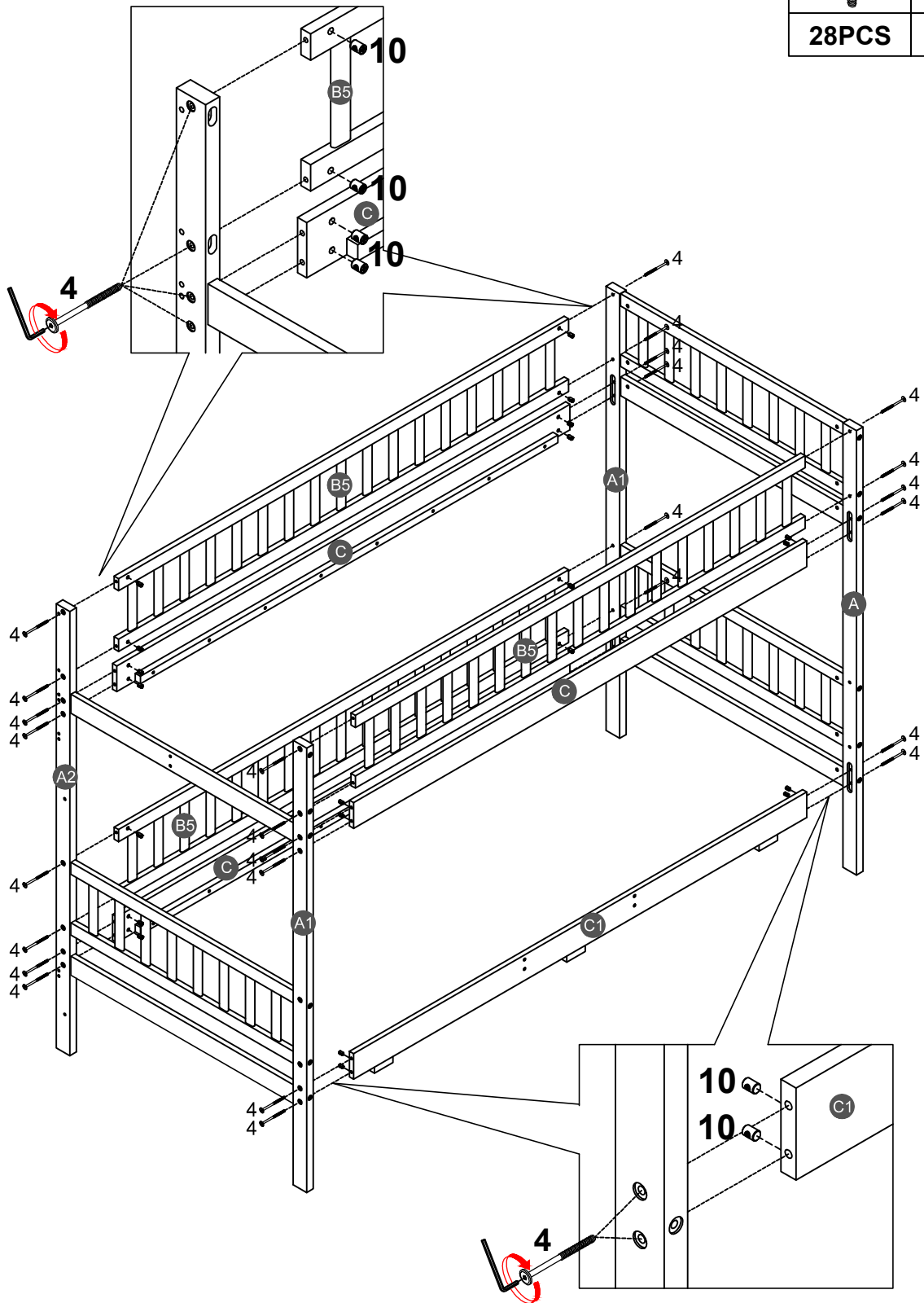

STEP 4:
ÉTAPE

4		10	
28PCS		28PCS	





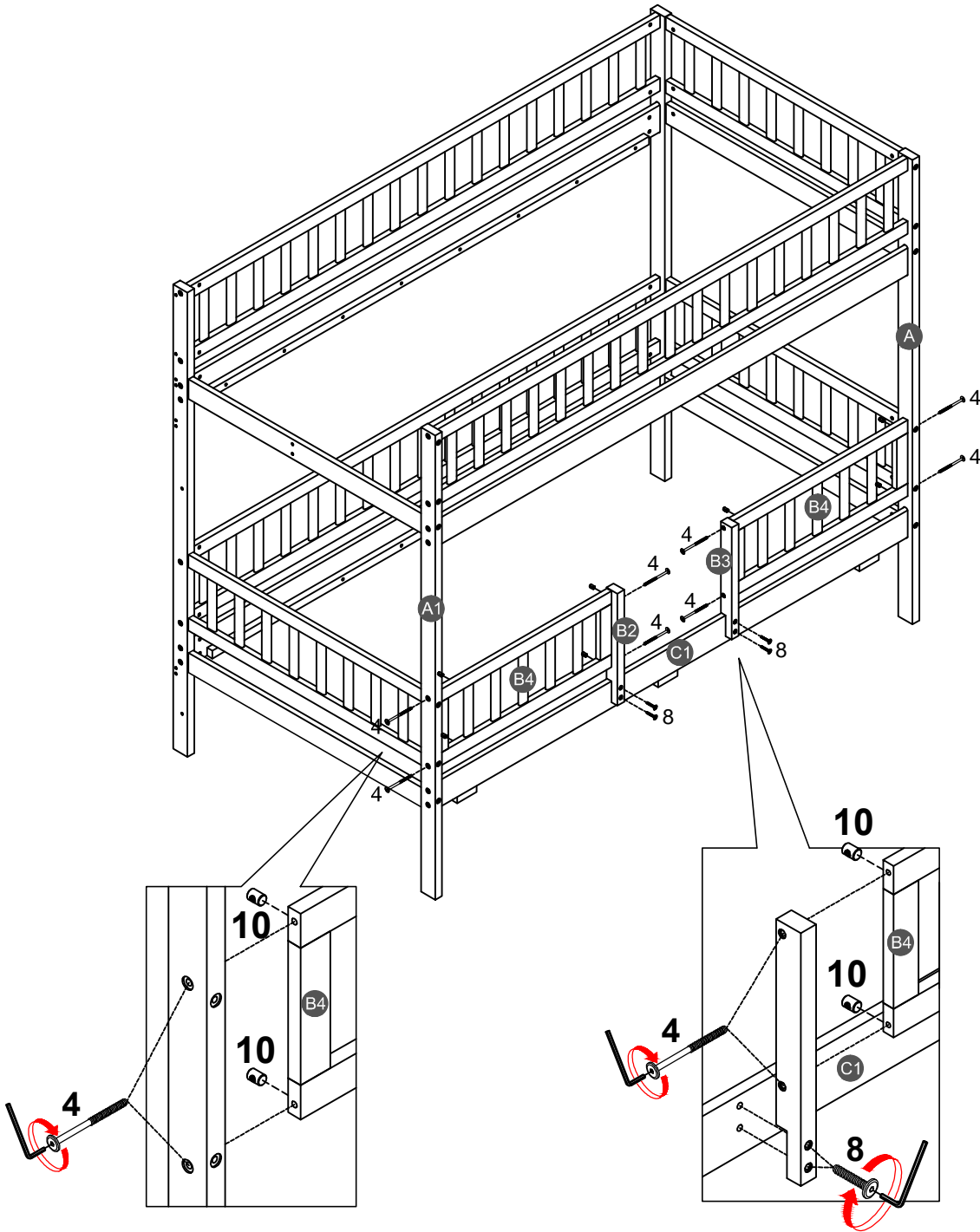

STEP 5:
ÉTAPE

4		8		10	
8PCS		4PCS		8PCS	



STEP 6:
ÉTAPE

3		5		8		10	
2PCS		2PCS		2PCS		4PCS	

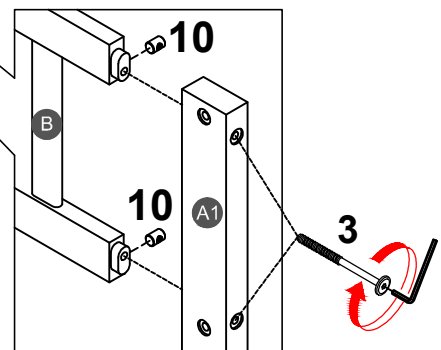
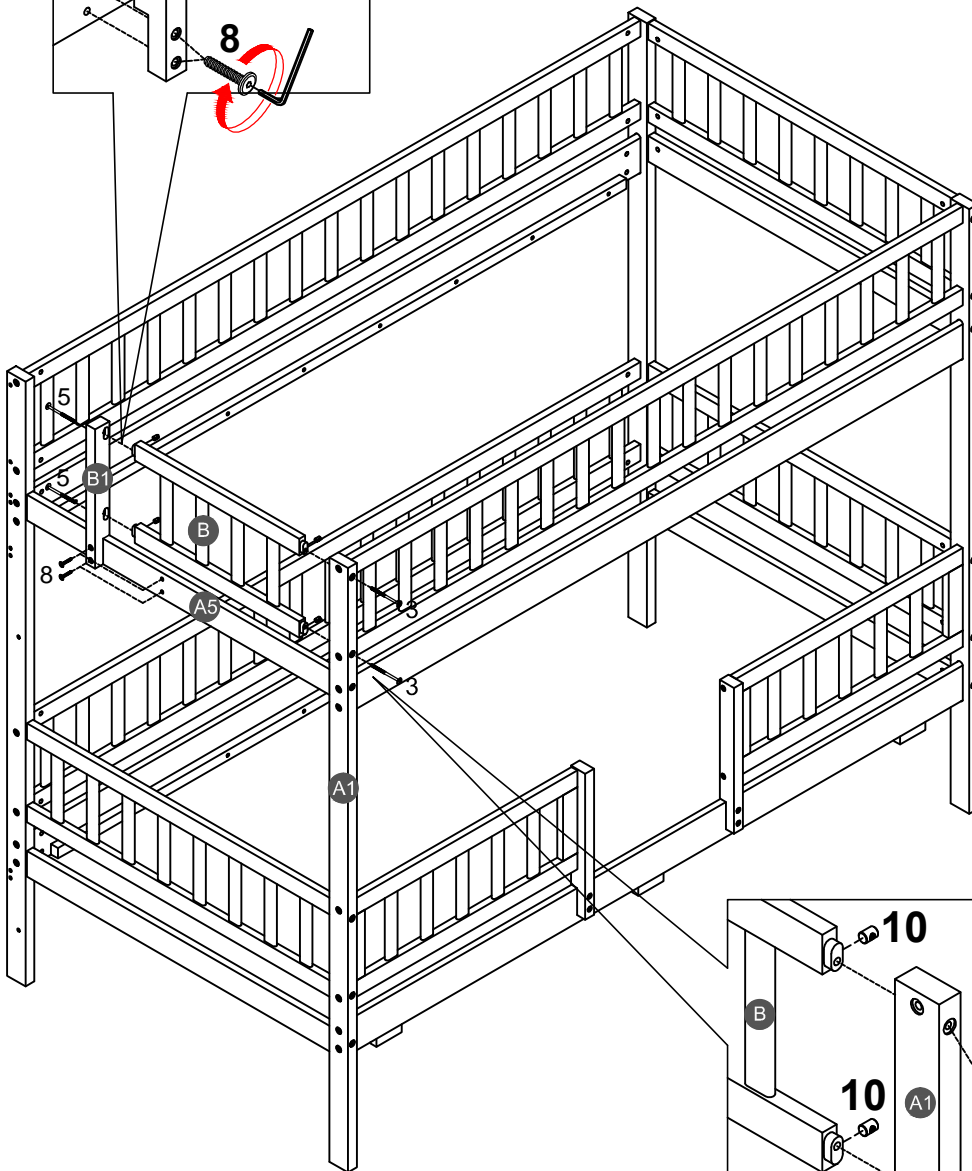
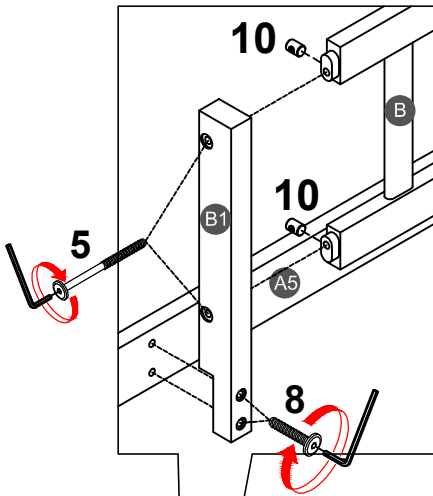

STEP 7:

ÉTAPE

14



56PCS

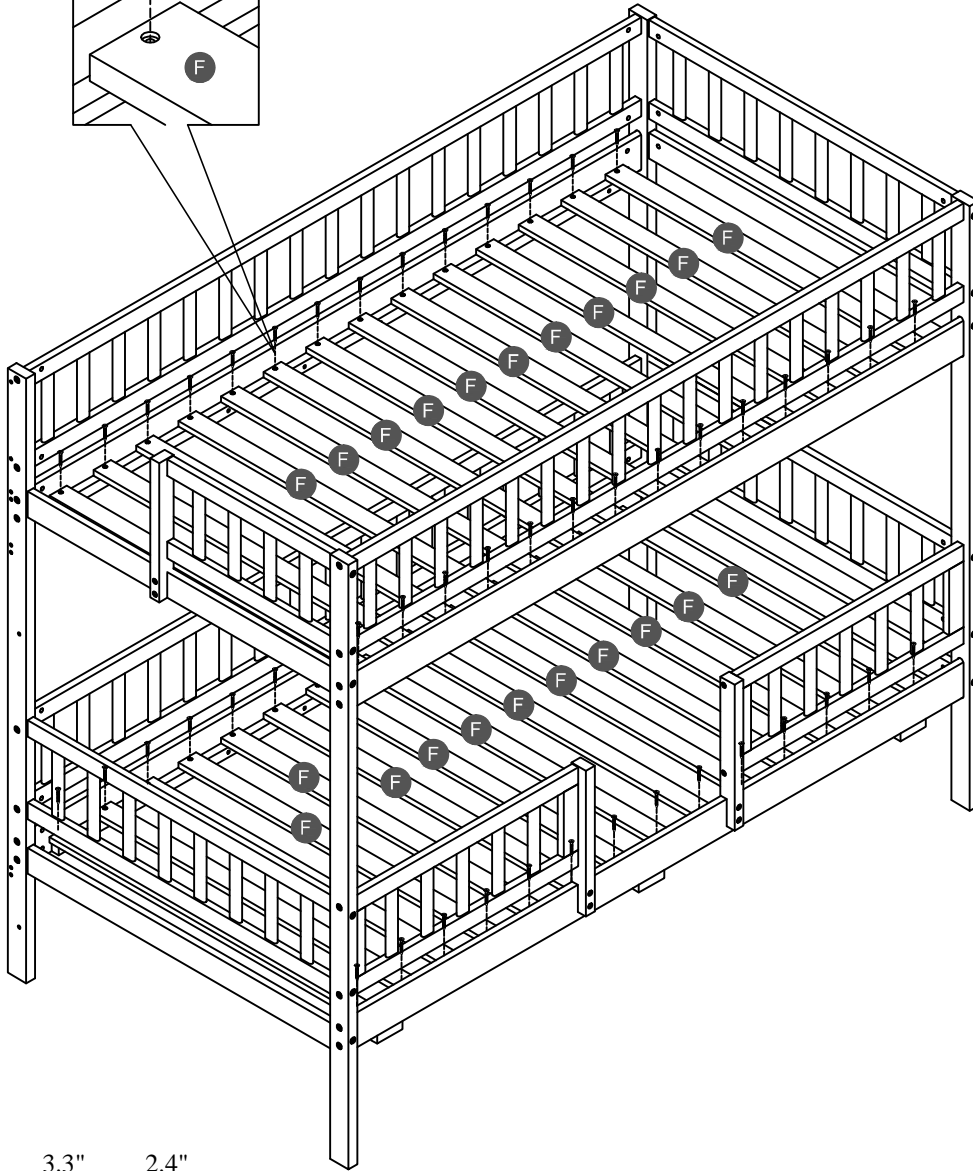
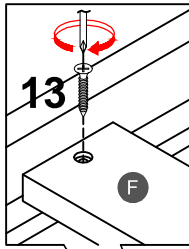

3.1" 79mm 3.3" 84mm 2.4" 61mm

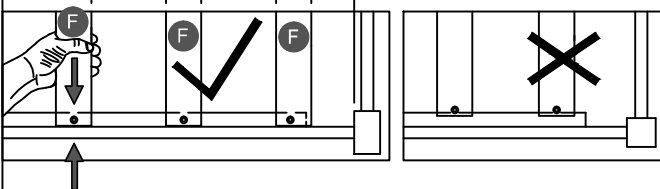



NOTE: Please make sure the bed slats close to the side rail before locking the screws to avoid breakage. This step is required for both the left and right sides. Moreover, please do not lock the screws of the bed slats at the outermost edge to avoid damaging.

Remarque: Assurez-vous Les lattes du lit fermer du rail latéral avant de verrouiller les vis pour éviter la casse. Cette étape est requise pour tous les deux côtés gauche et droit. De plus, ne verrouillez pas les vis des lattes de lit sur le bord le plus extérieur pour éviter d'endommager.

STEP 8:

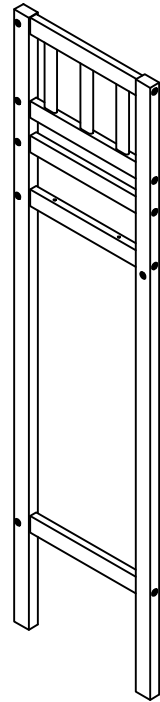
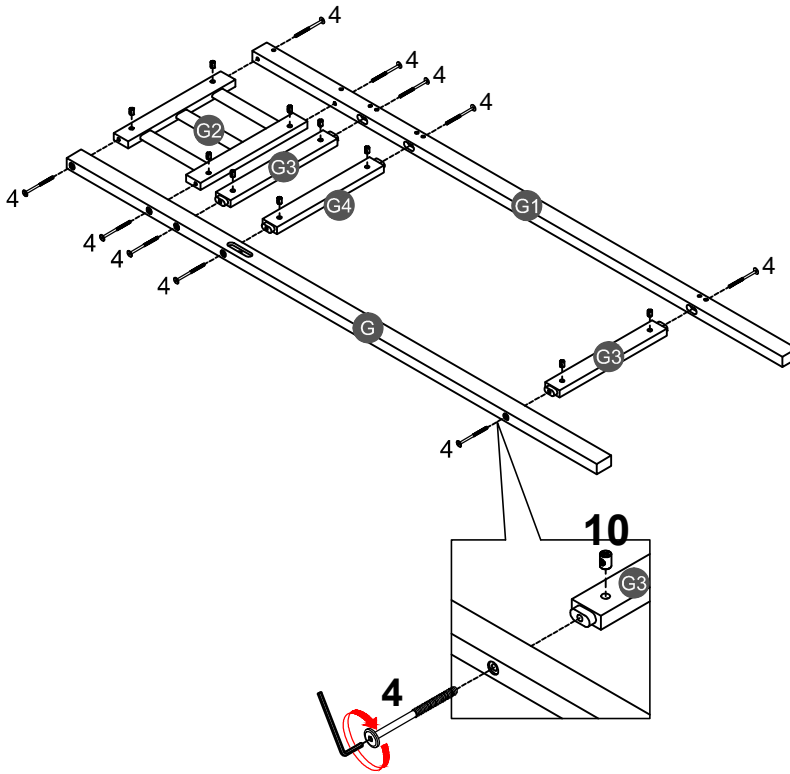

ÉTAPE

4		10	
10PCS		10PCS	



STEP 9:

ÉTAPE

1		11		12	
1PC		1PC		12PCS	

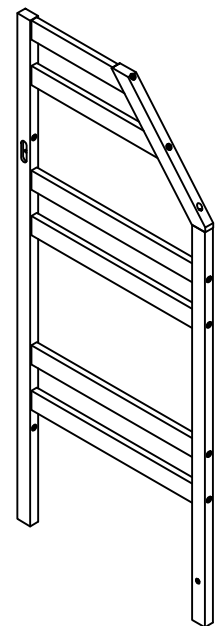
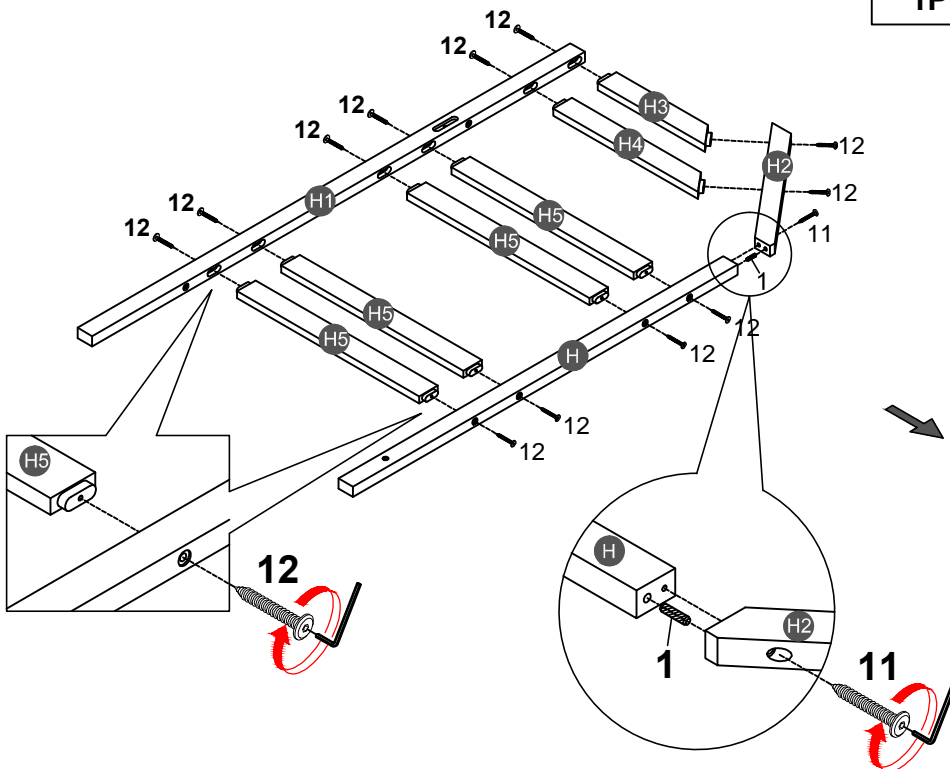

STEP 10:

ÉTAPE

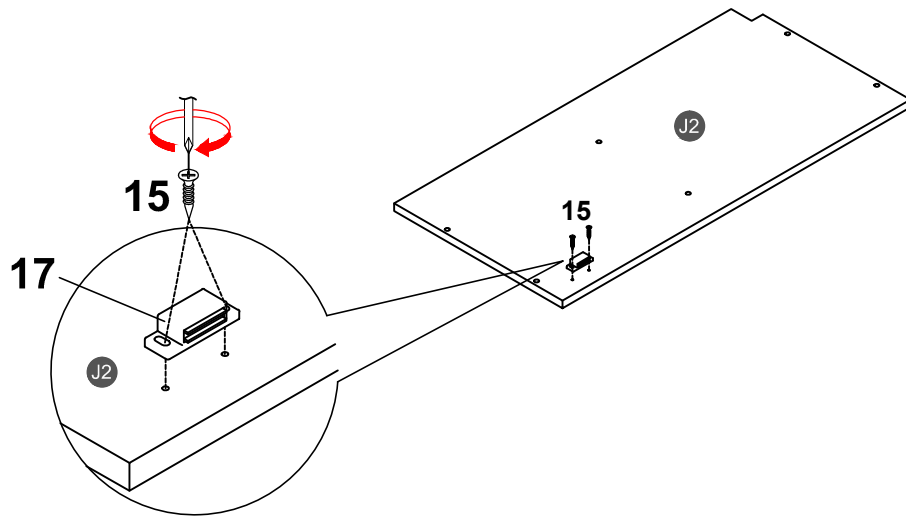

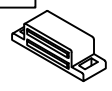
15		17	
2PCS		1PC	

STEP 11:

ÉTAPE

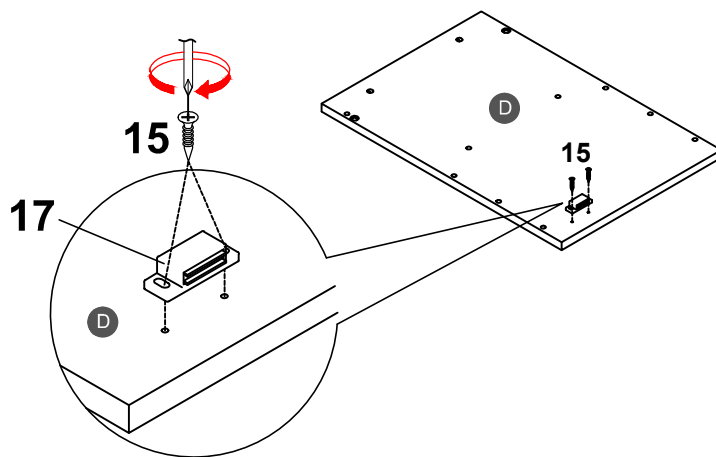

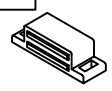
15		17	
2PCS		1PC	

STEP 12:

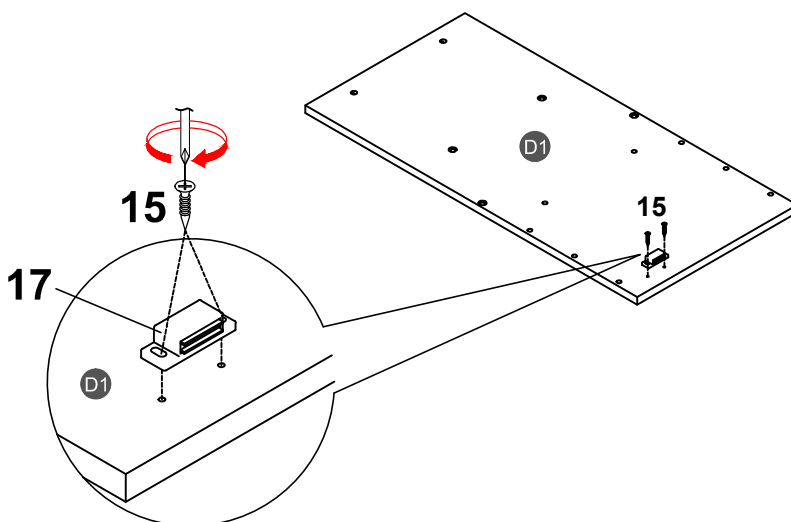

ÉTAPE

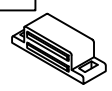

15		17	
2PCS		1PC	

STEP 13:

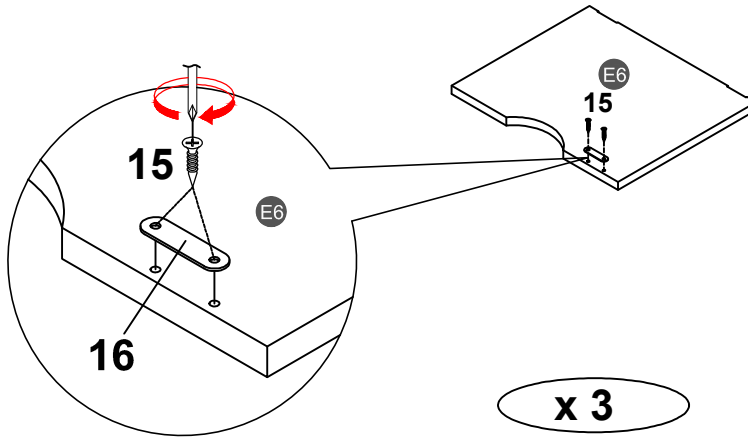

ÉTAPE

15		16	
6PCS		3PCS	



STEP 14:

ÉTAPE

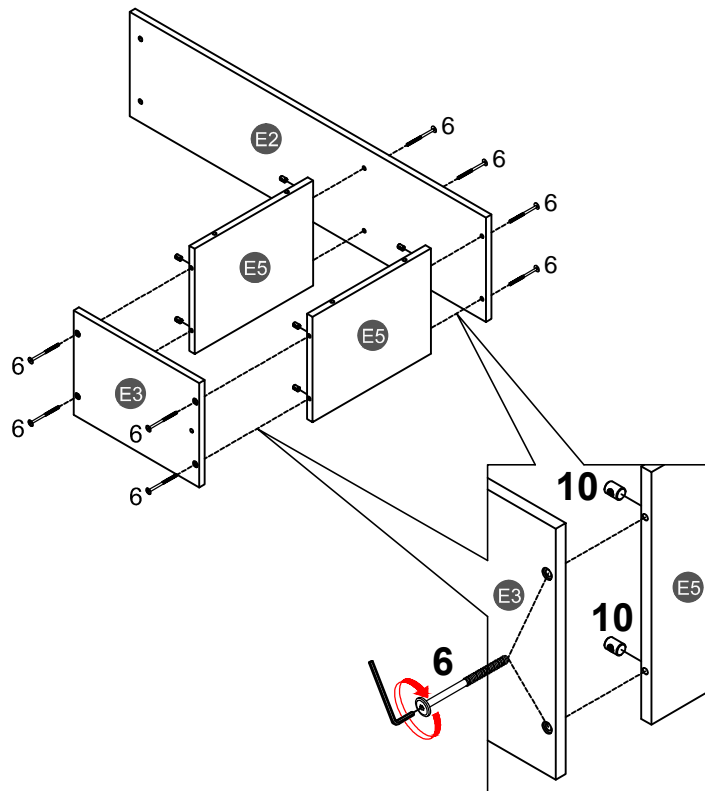

6		10	
8PCS		8PCS	

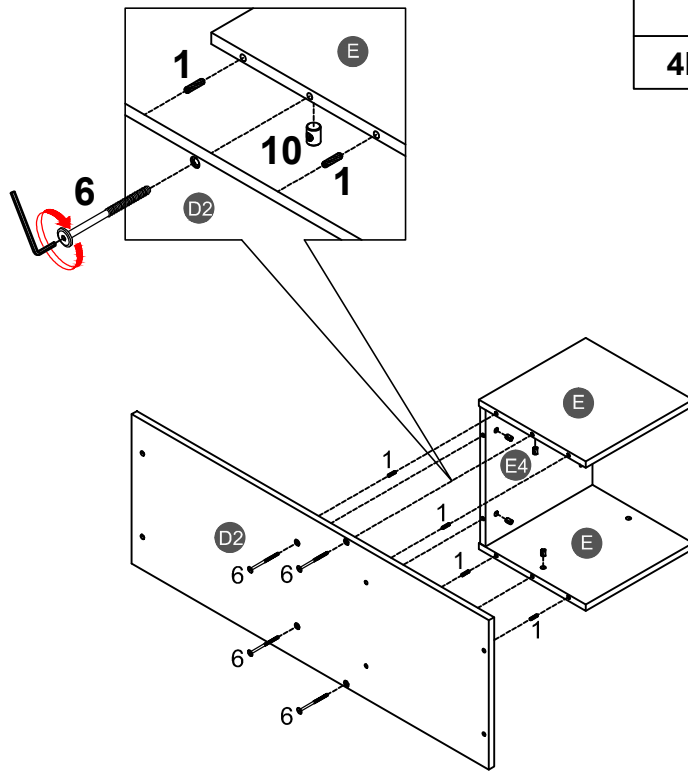

STEP 15:

ÉTAPE





1		6		10	
4PCS		4PCS		4PCS	

STEP 16:

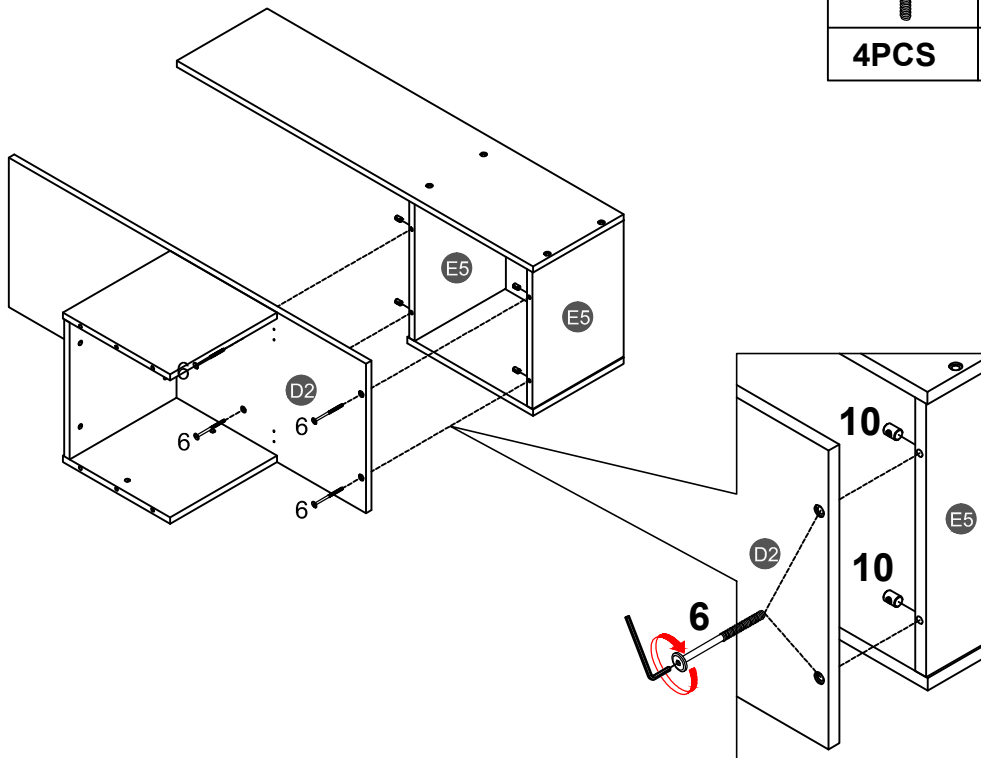

ÉTAPE



6		10	
4PCS		4PCS	

STEP 17:

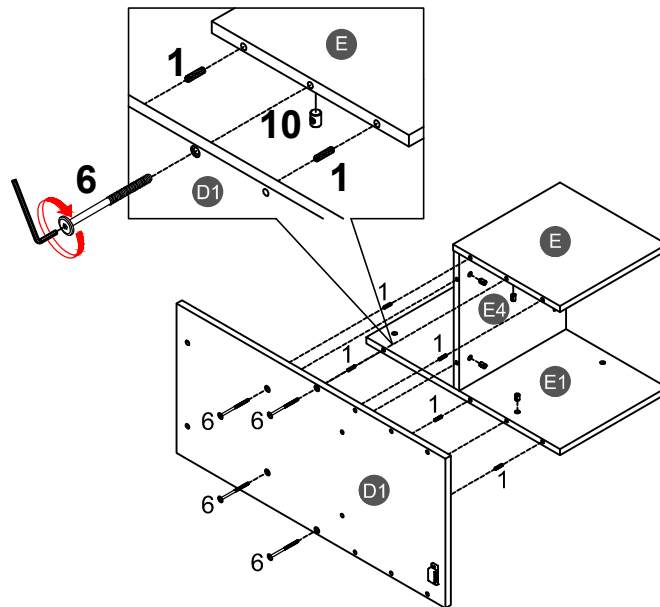

ÉTAPE

1		6		10	
5PCS		4PCS		4PCS	



STEP 18:

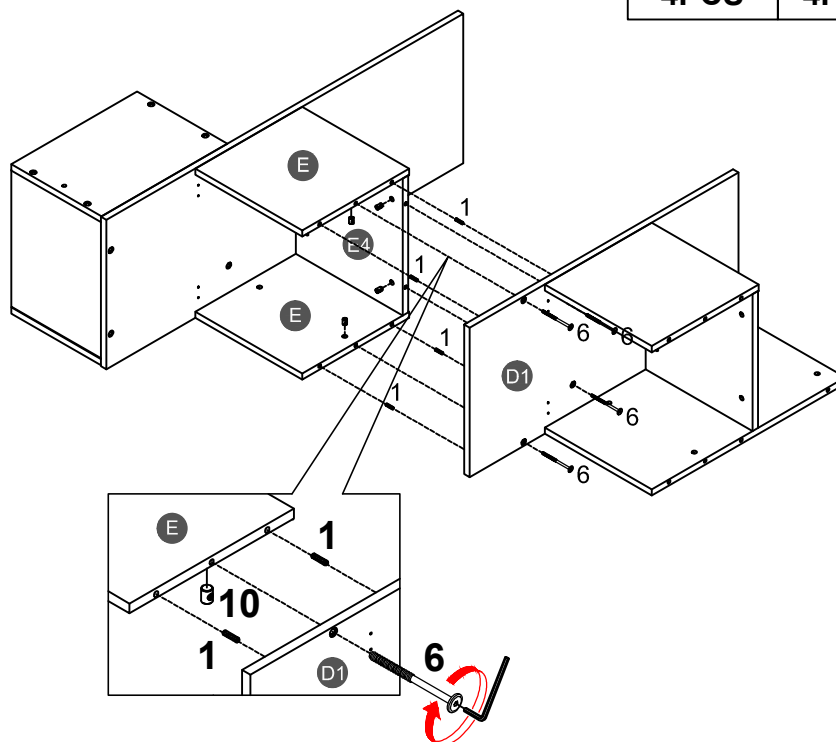

ÉTAPE

1		6		10	
4PCS		4PCS		4PCS	



STEP 19:

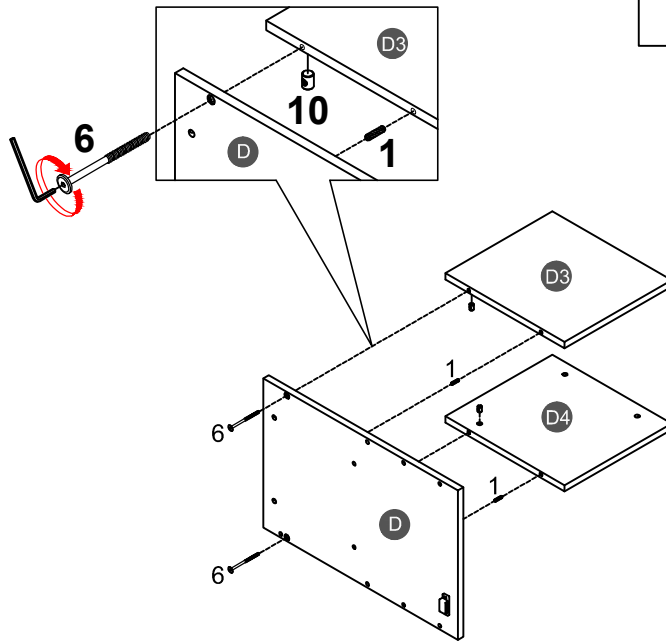

ÉTAPE

1		6		10	
2PCS		2PCS		2PCS	



STEP 20:

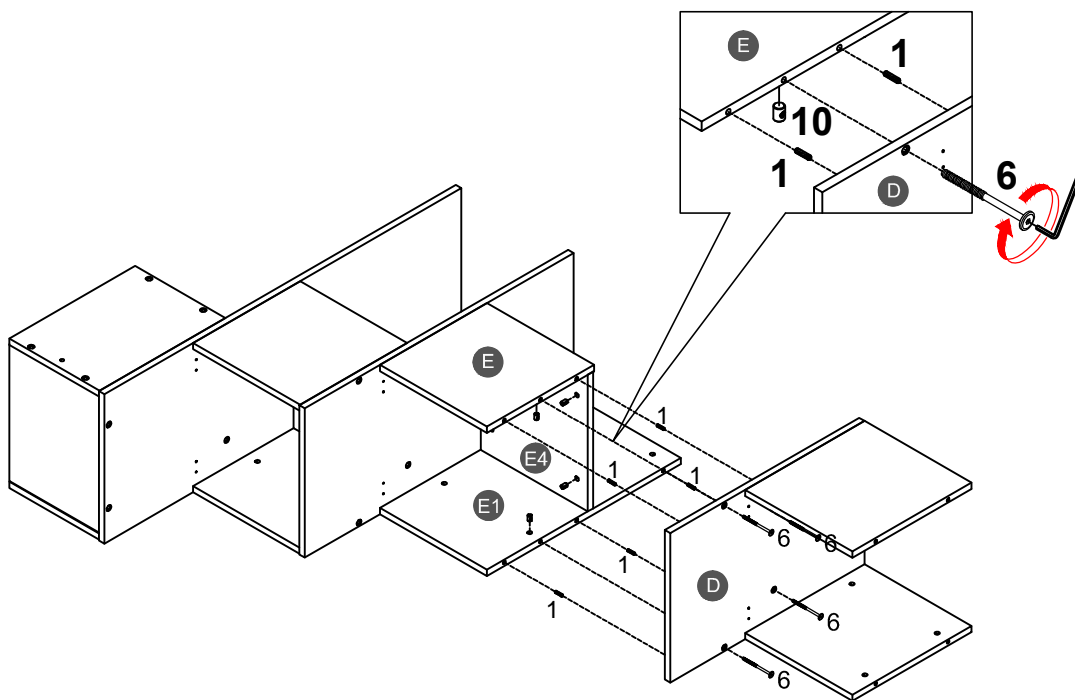

ÉTAPE

1		6		10	
5PCS		4PCS		4PCS	



STEP 21:

ÉTAPE

6		10	
10PCS		10PCS	

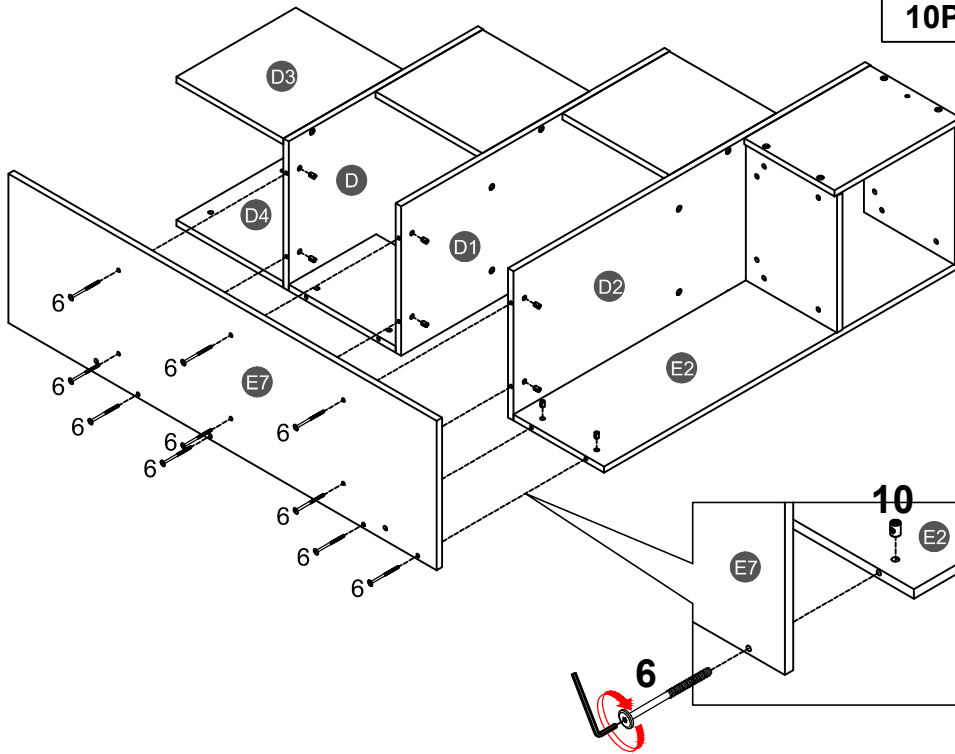

STEP 22:

ÉTAPE

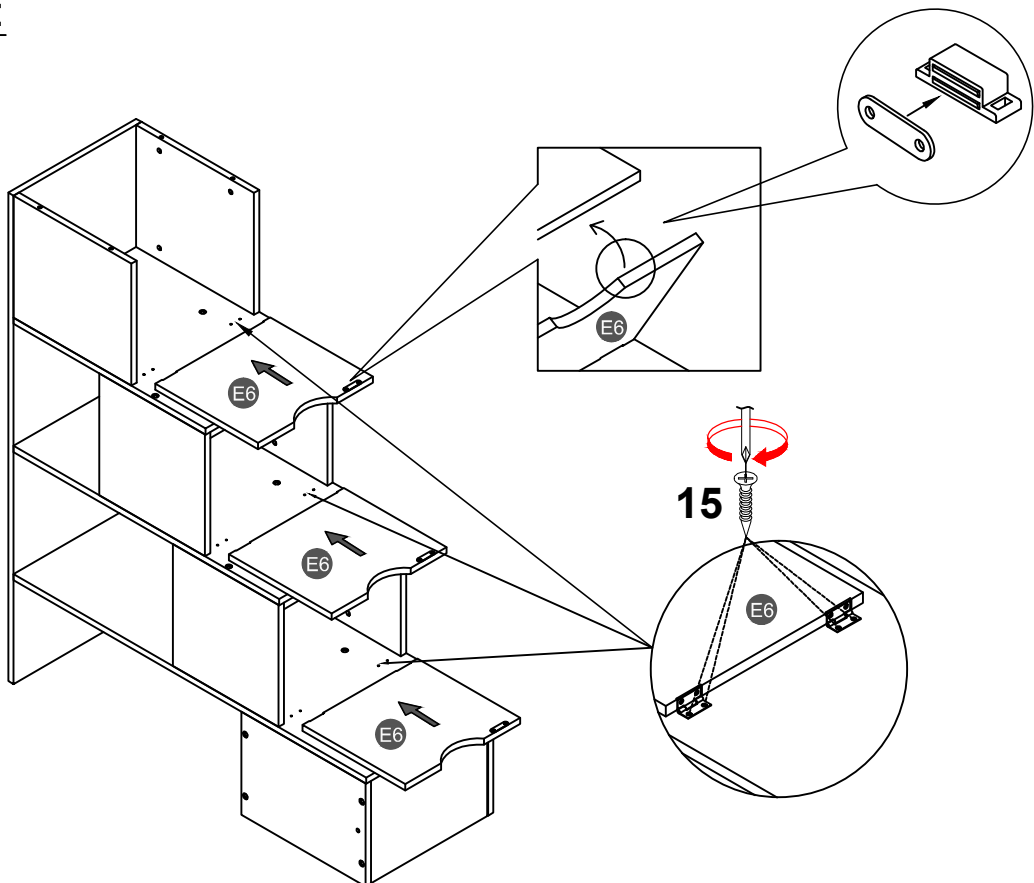



15	
12PCS	

STEP 23:

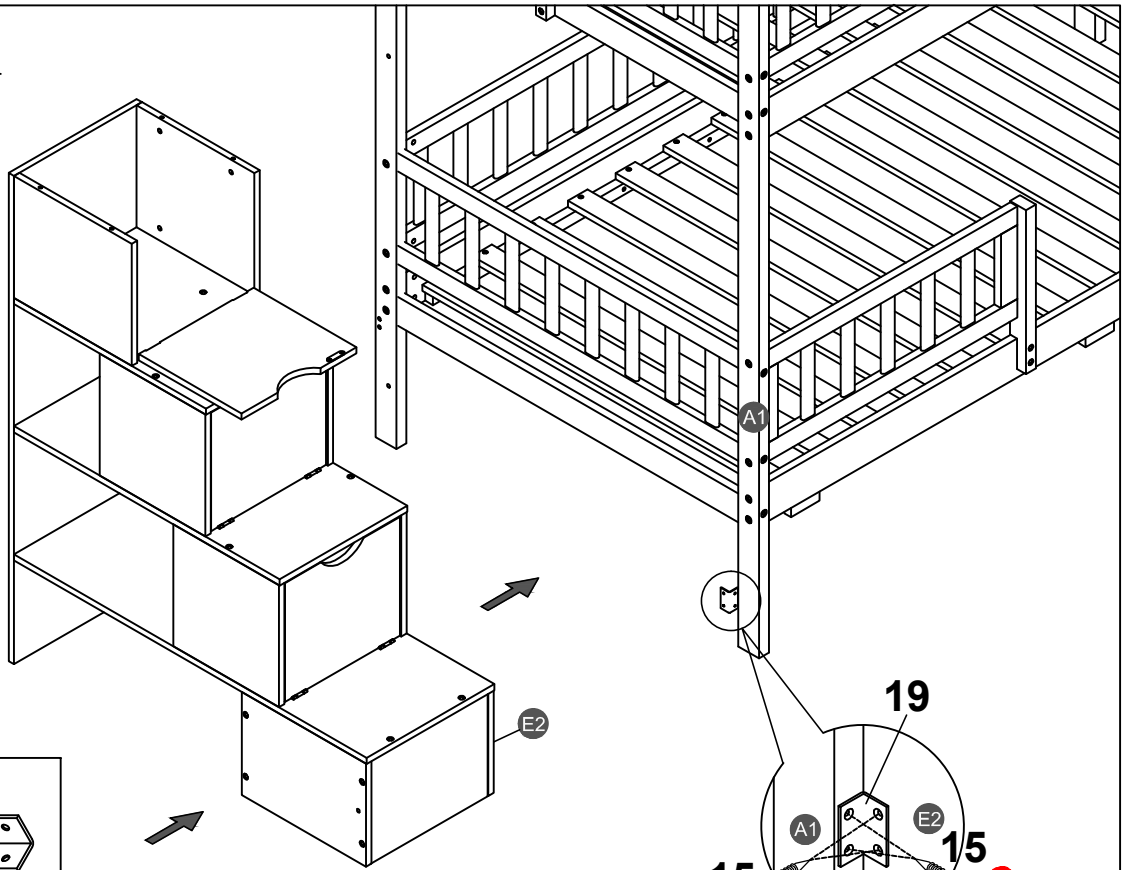
ÉTAPE



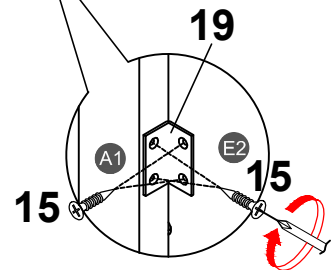

15 	19 
4PCS	1PC

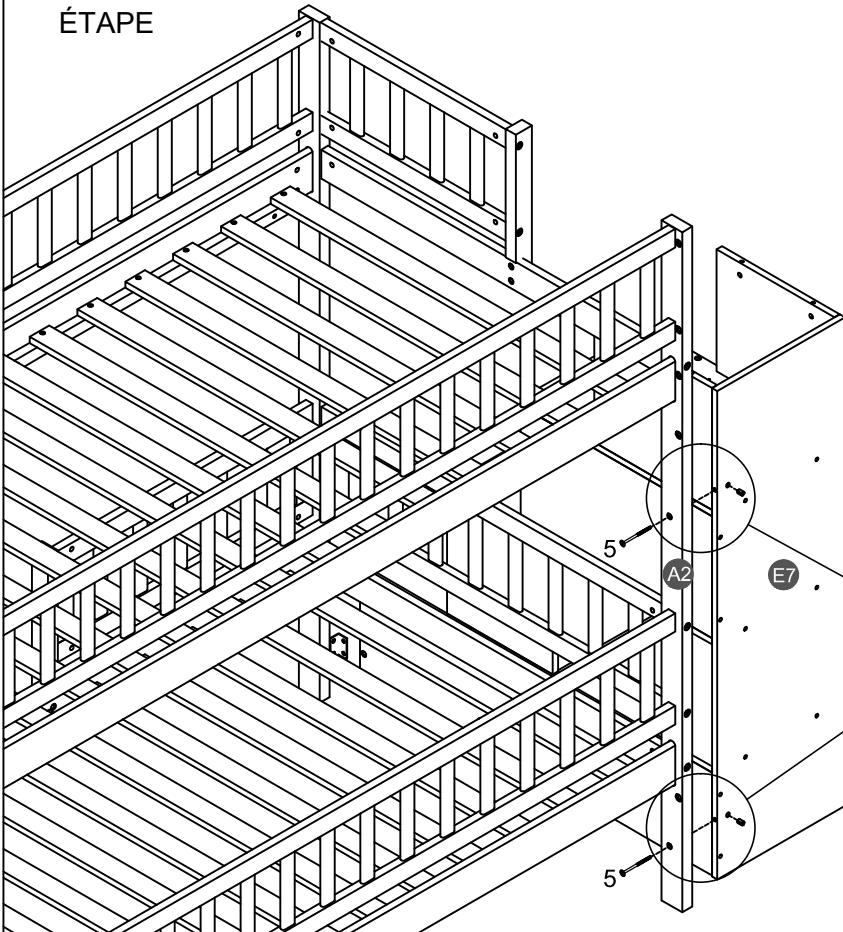

STEP 24:

ÉTAPE



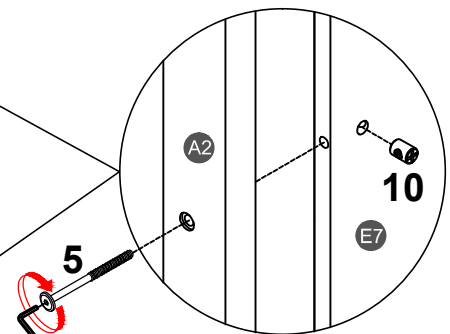

5 	10 
2PCS	2PCS



STEP 25:

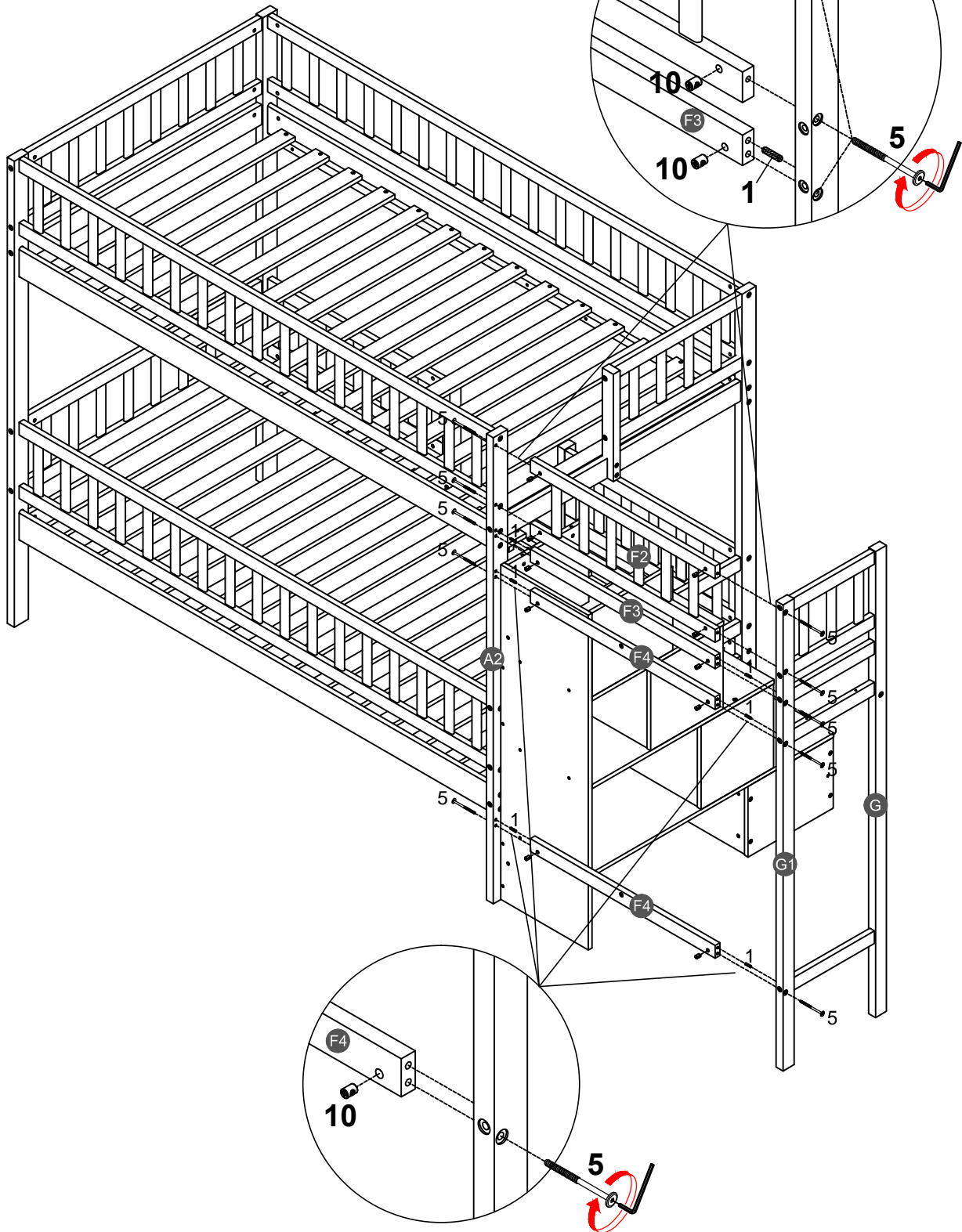

ÉTAPE

1 	5 	10 
6PCS	10PCS	10PCS



STEP 26:



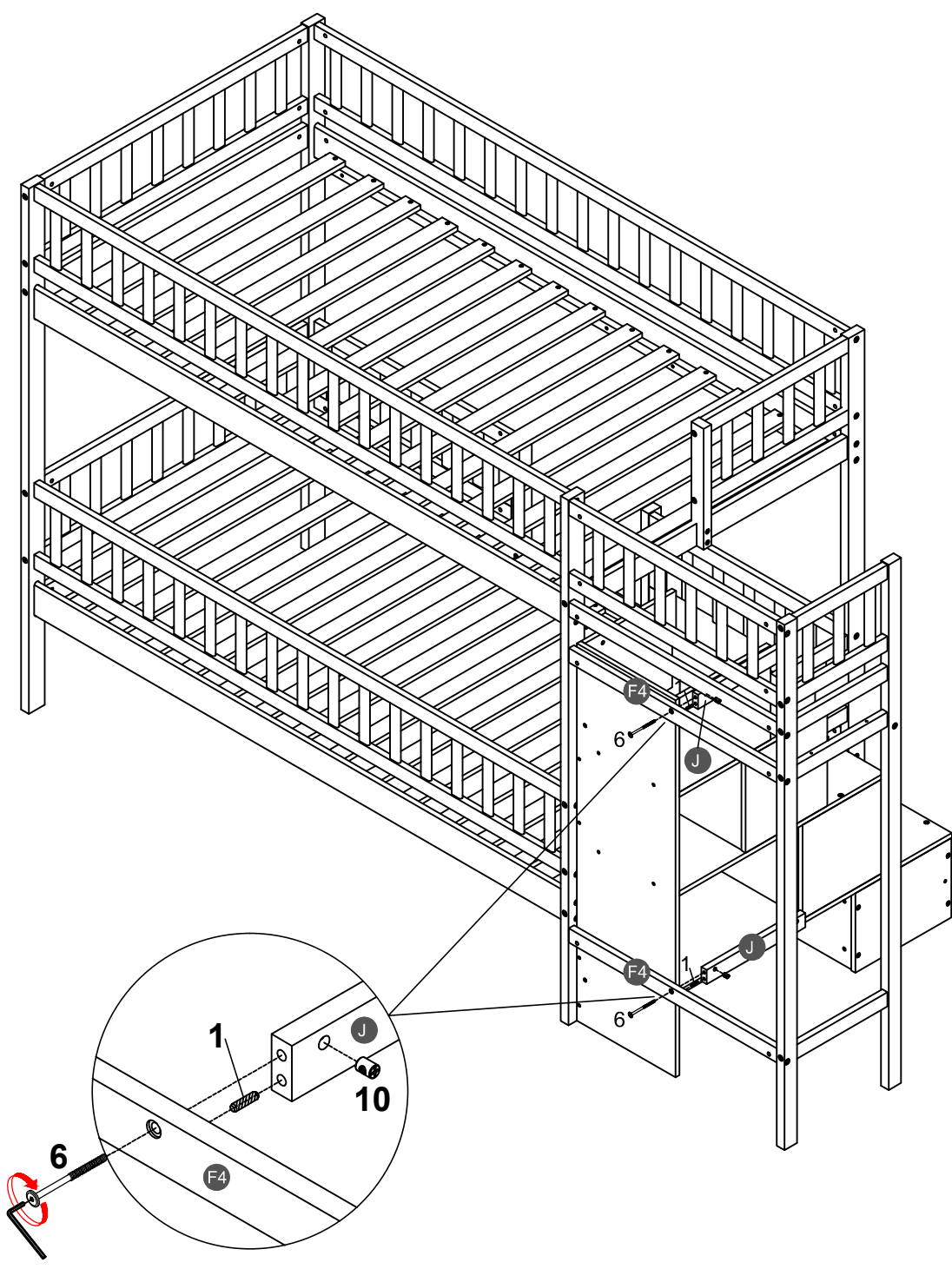

ÉTAPE

1		6		10	
2PCS		2PCS		2PCS	



STEP 27:

ÉTAPE

1		4		5		7		10	
2PCS		2PCS		2PCS		1PC		4PCS	

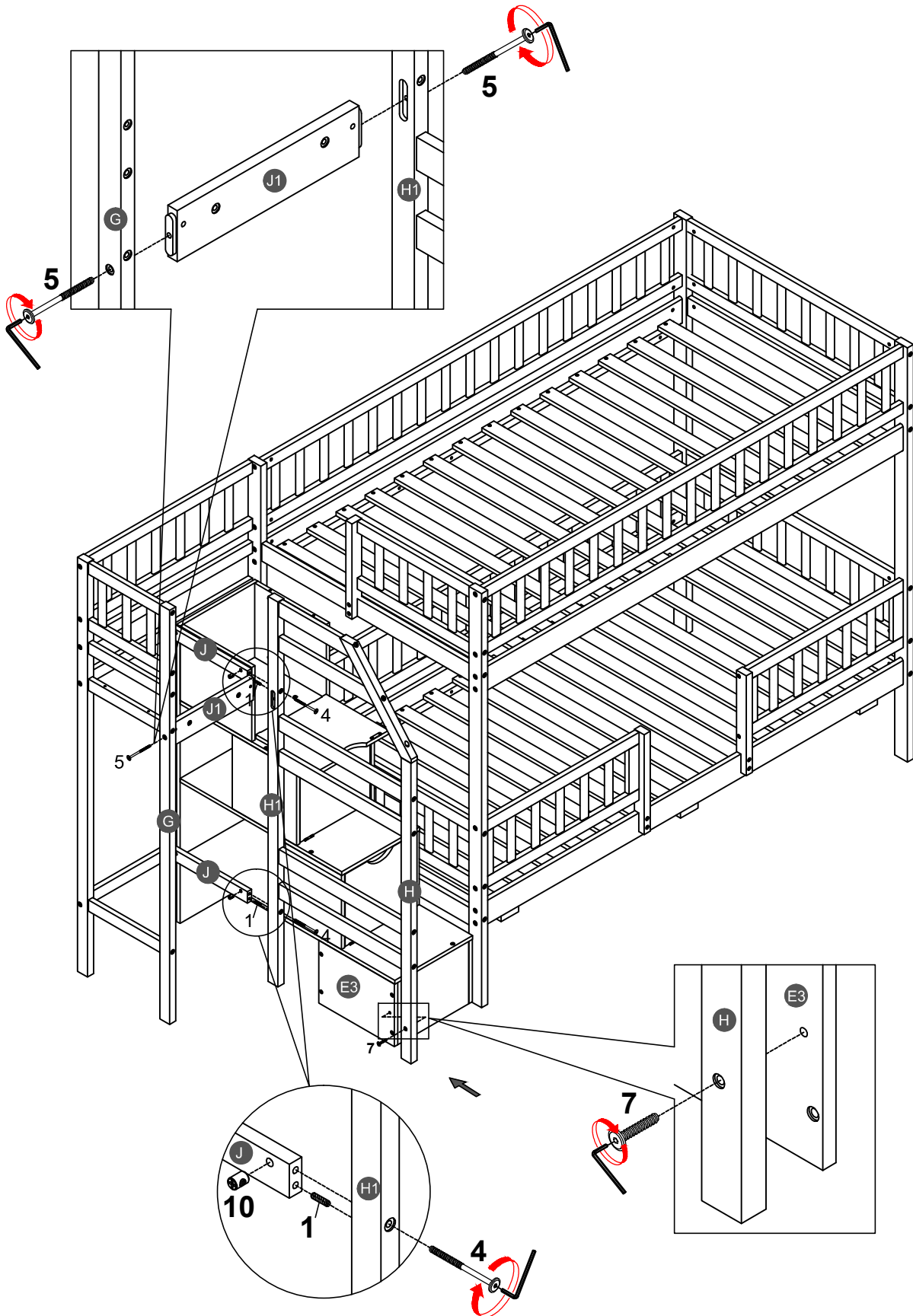

STEP 28:
ÉTAPE

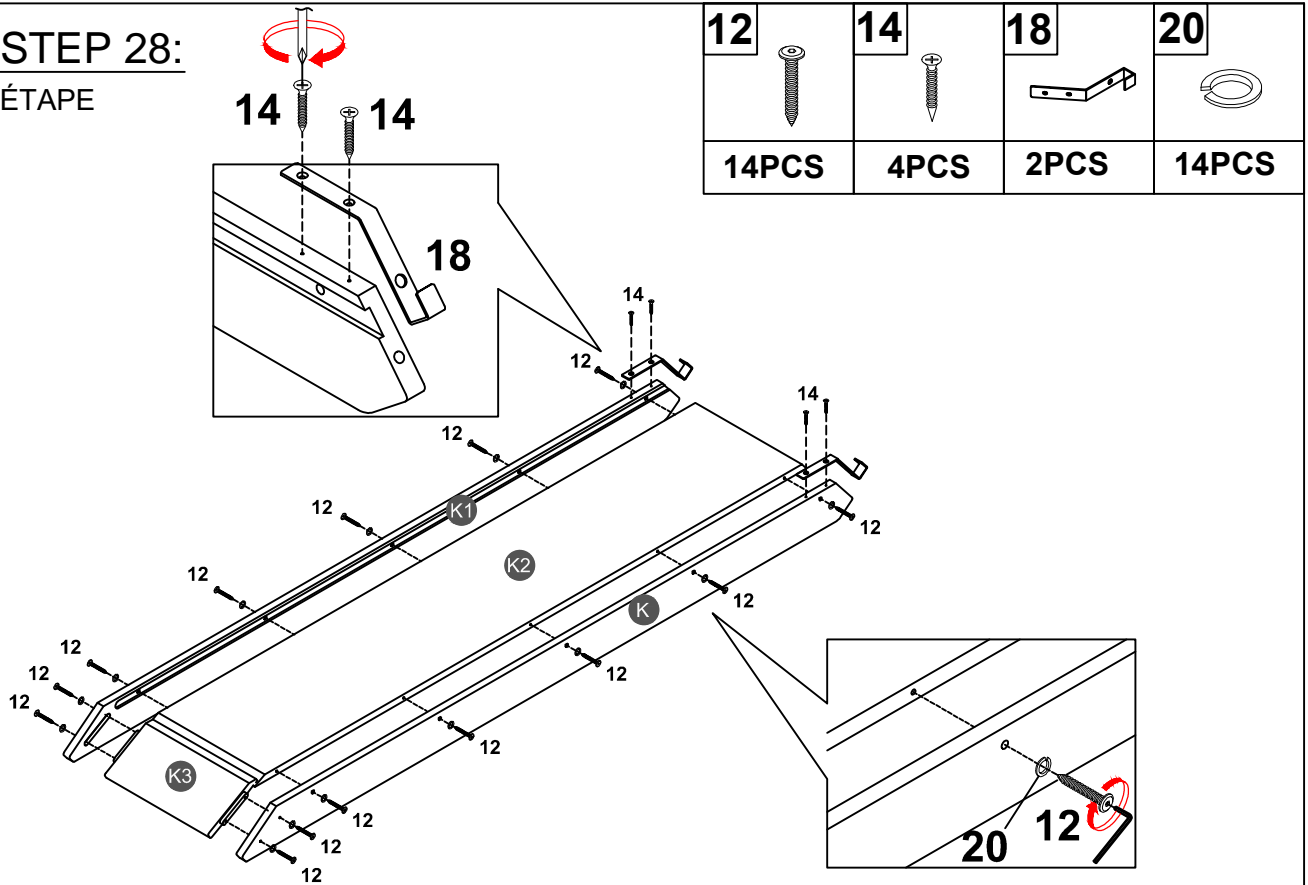

STEP 29:
ÉTAPE

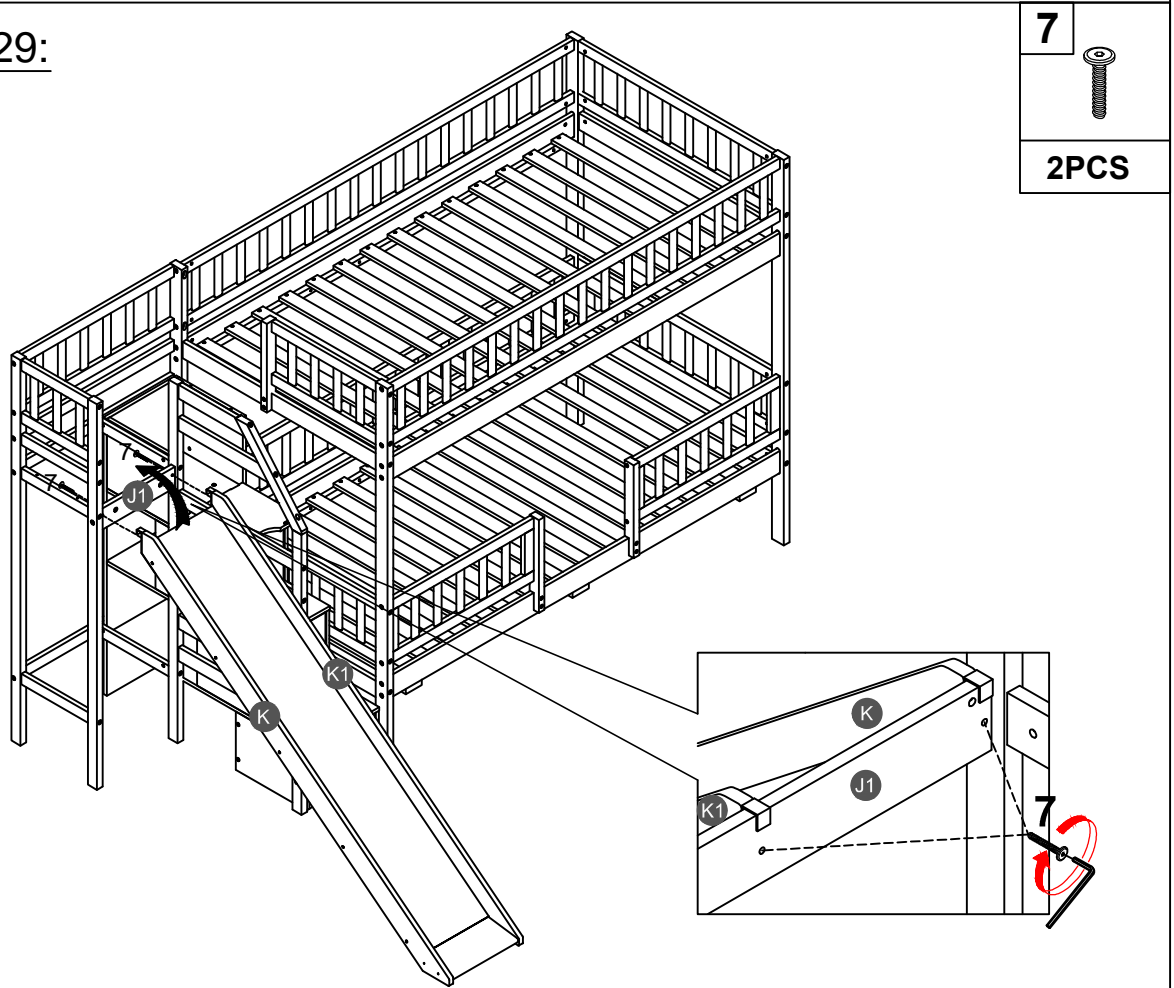

STEP 30:

ÉTAPE



9

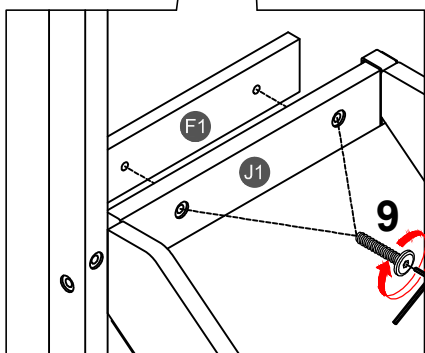
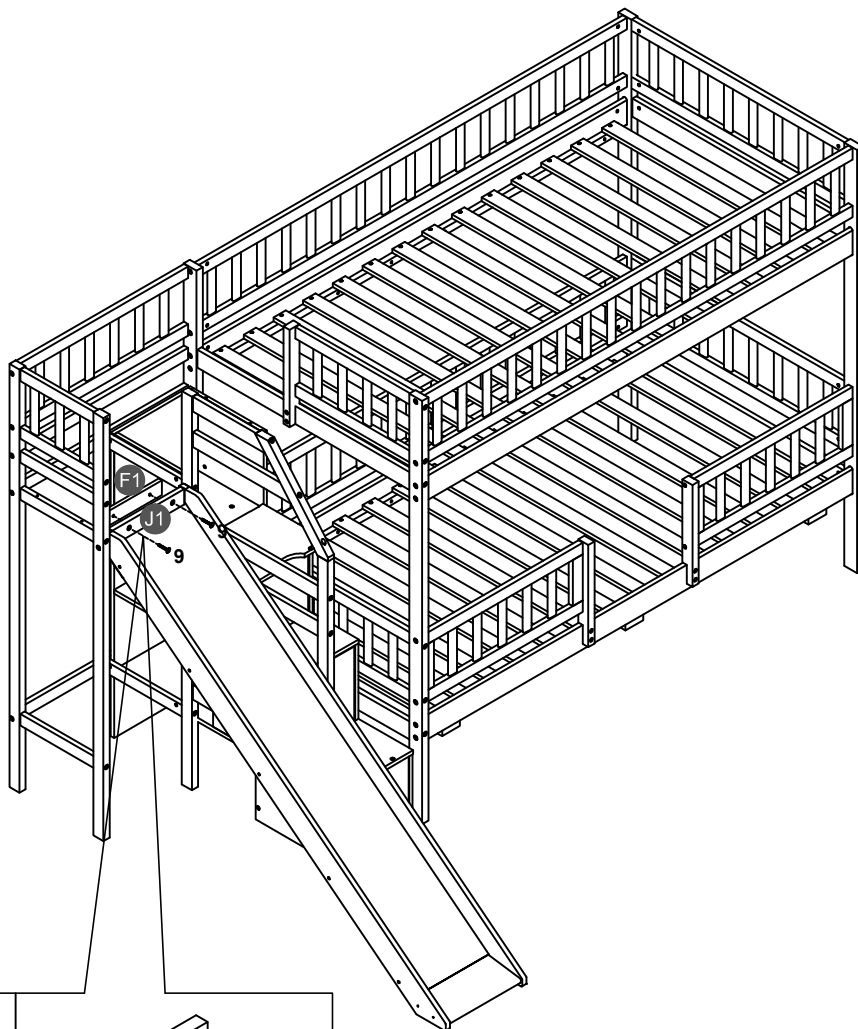

2PCS





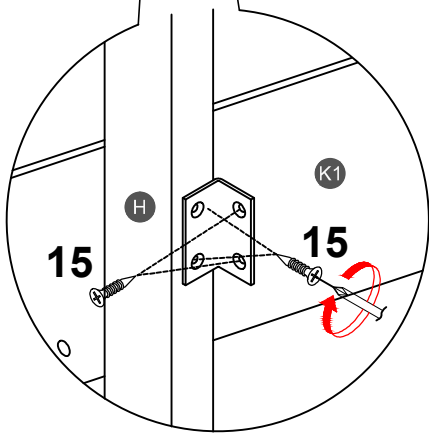
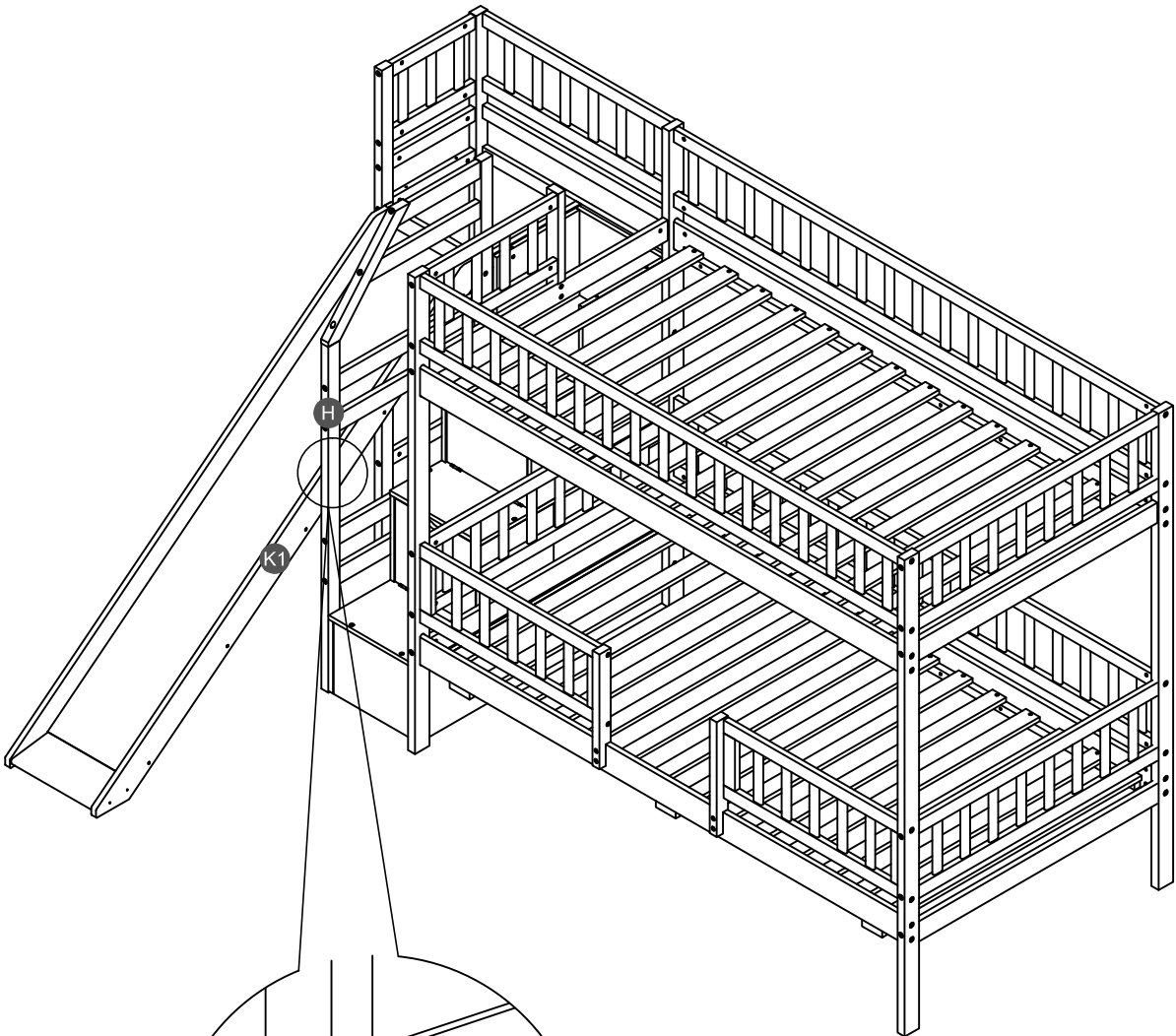

STEP 31:
ÉTAPE

15	19
	
4PCS	1PC



STEP 32:

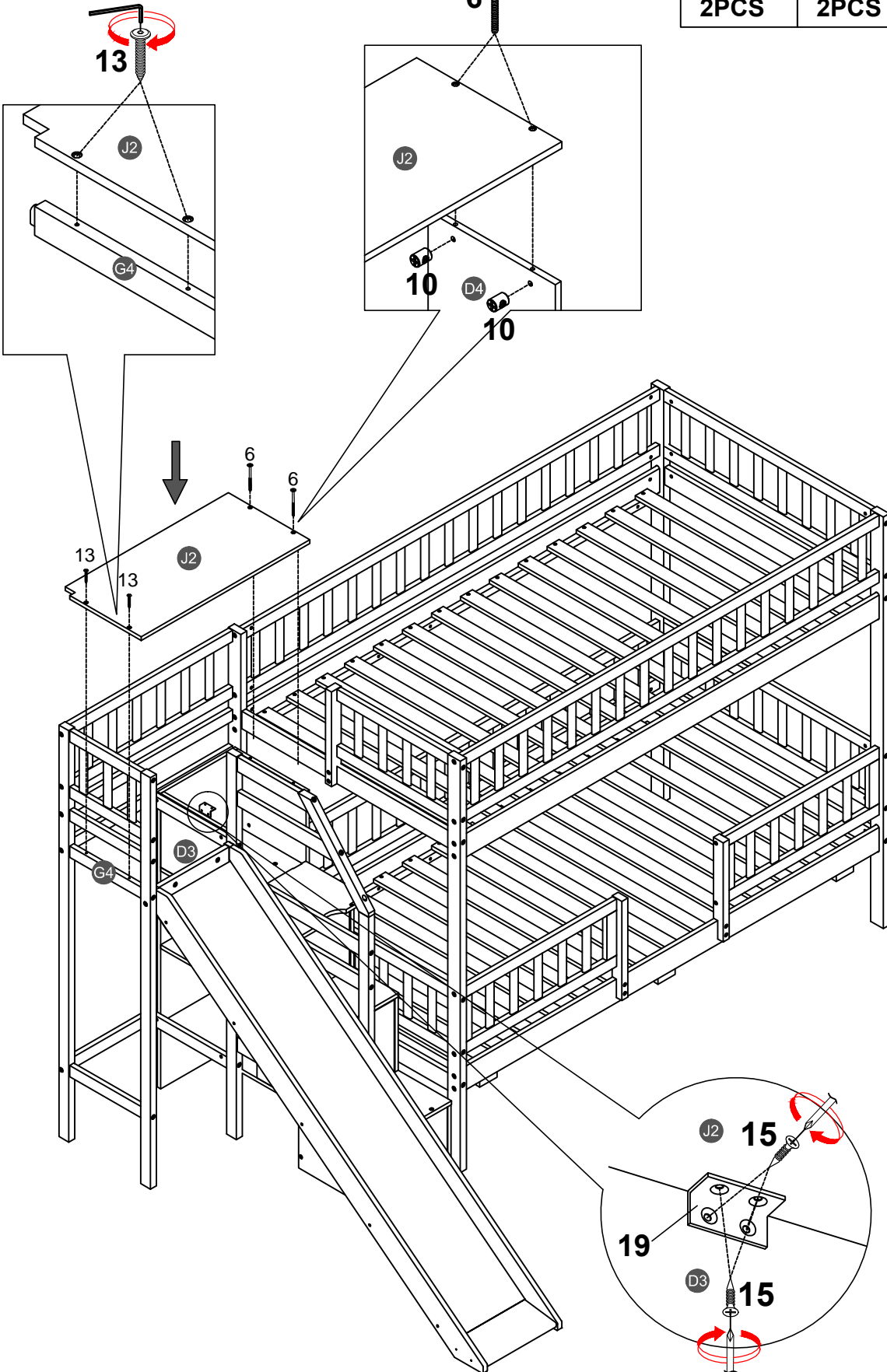

ÉTAPE

6 	10 	13 
2PCS	2PCS	2PCS
15 		
4PCS		
19 		
1PC		



STEP 33:

ÉTAPE

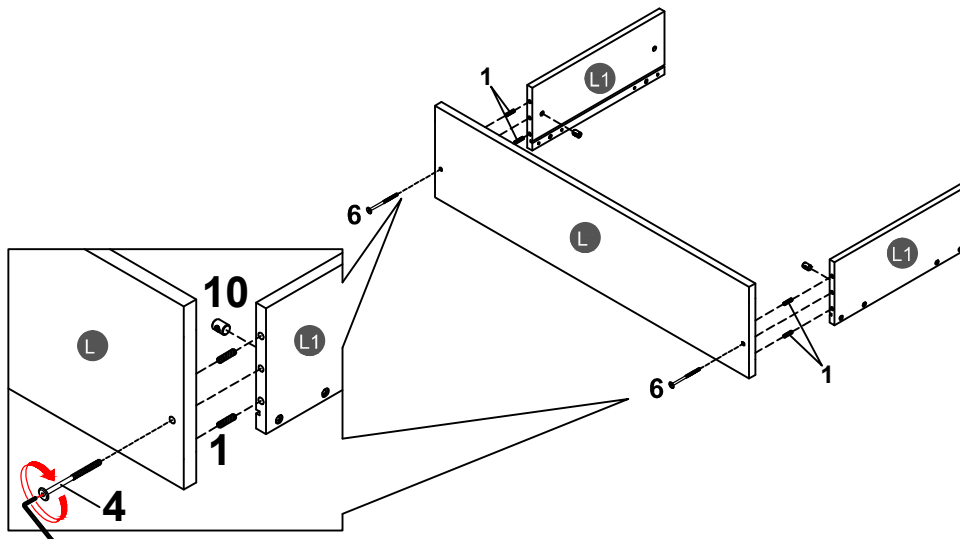

1		6		10	
8PCS		4PCS		4PCS	



2pcs

STEP 34:

ÉTAPE

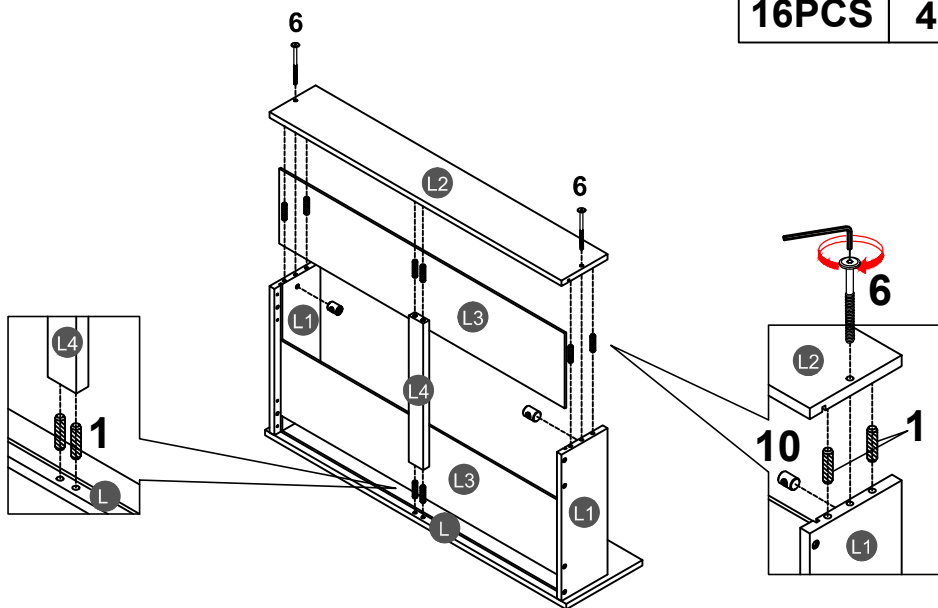

1		6		10	
16PCS		4PCS		4PCS	



2pcs

STEP 35:

ÉTAPE

2	14	21
		
8PCS	16PCS	8PCS

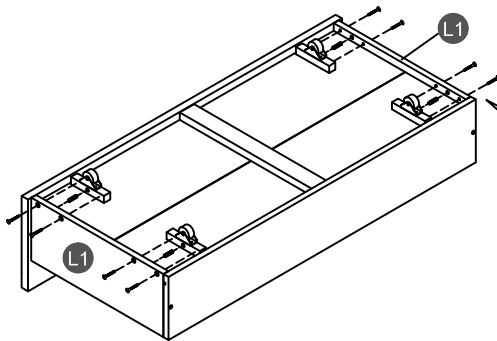

2pcs

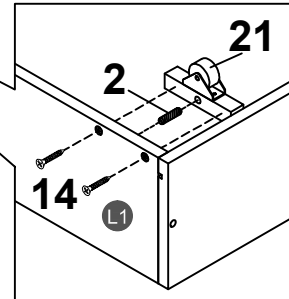

STEP 36:

ÉTAPE

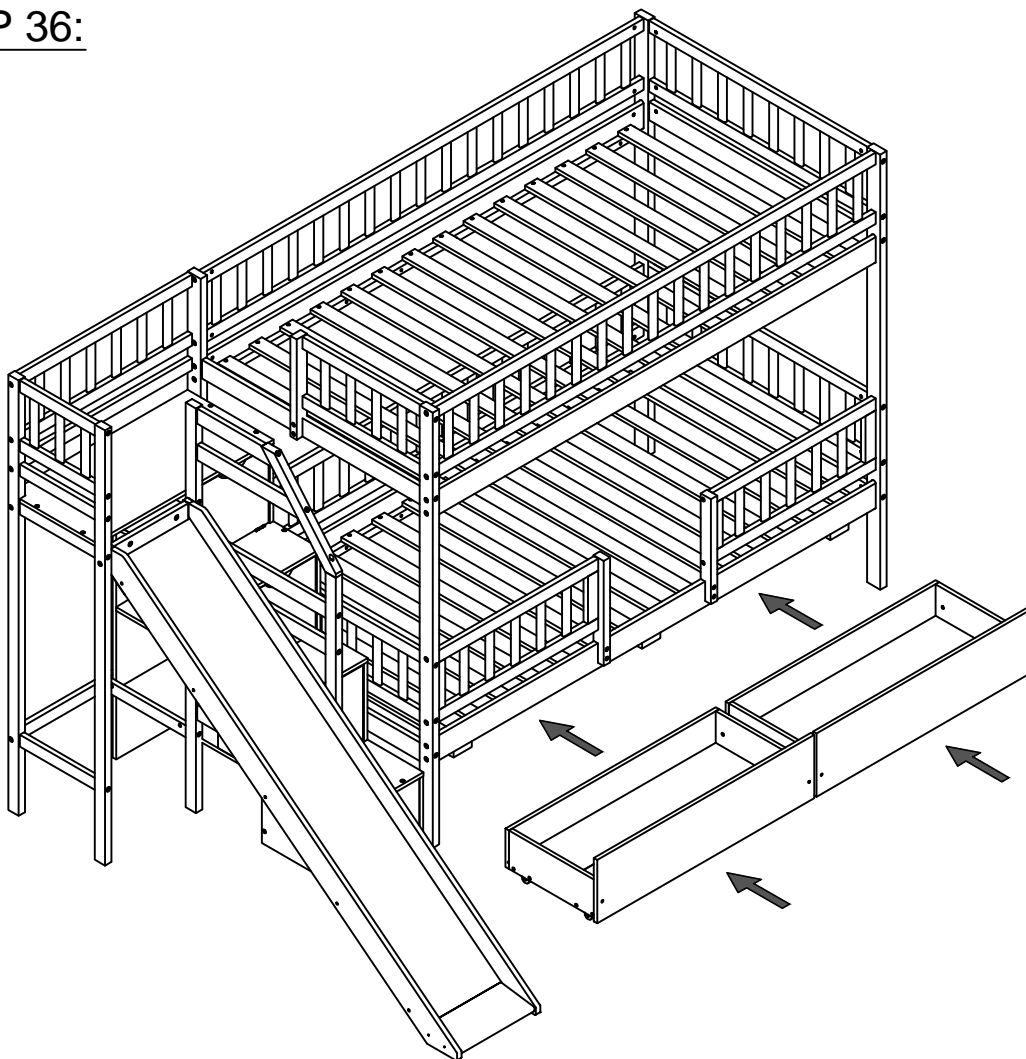

Push drawer under the bottom of Bunkbed.

Poussez le tiroir sous le bas du lit superposé.

