

ASSEMBLY INSTRUCTION

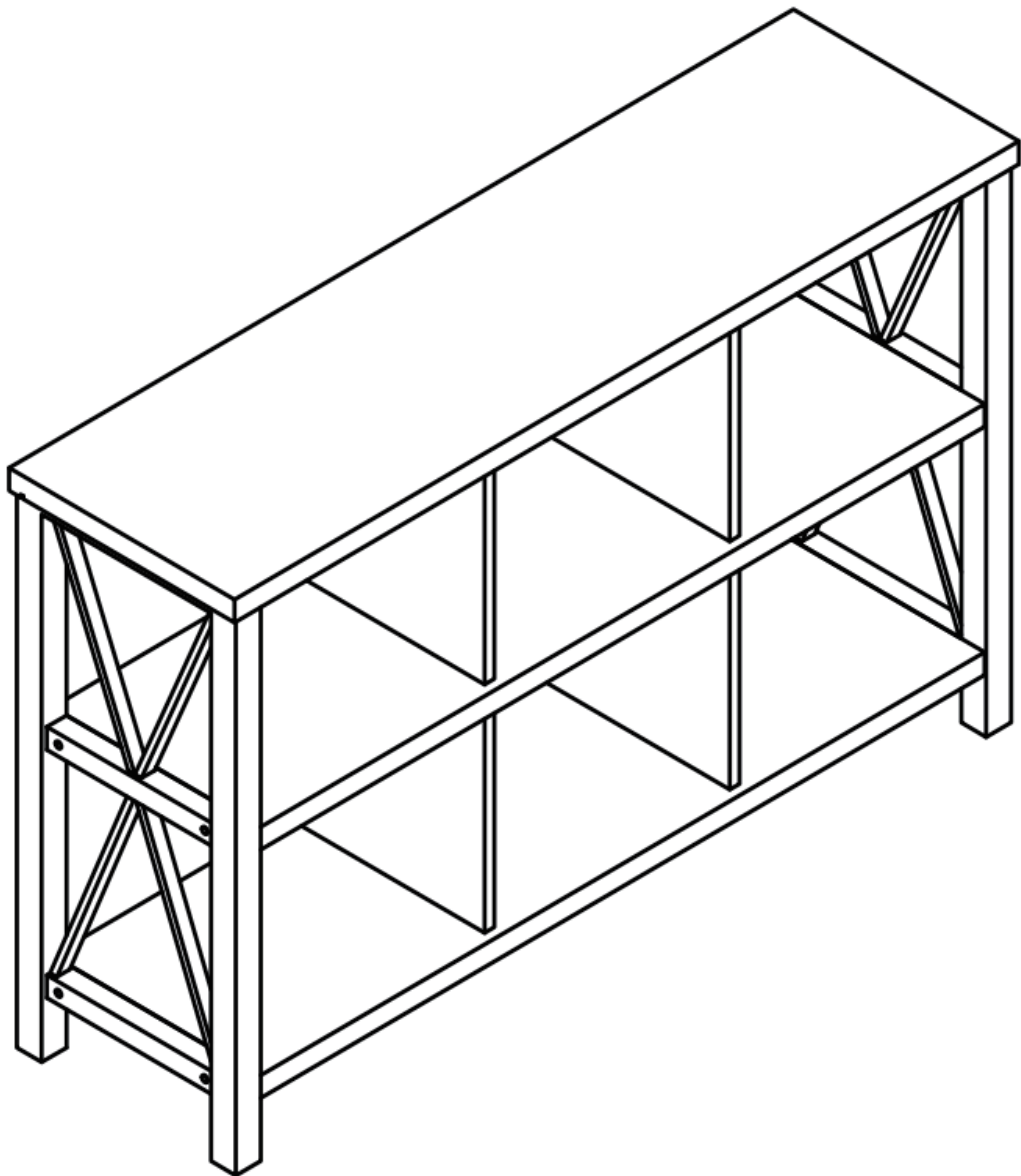

Thank you for purchasing our bookcase. If any parts missed or damaged, please do not hesitate to contact with us, we will send you the replacement parts immediately.

ASSEMBLY TIPS, IT IS AS EASY AS 1,2,3

1. Please read the assembly instructions first and become familiar with the parts.
2. Proper assembly of this item requires 2 people.

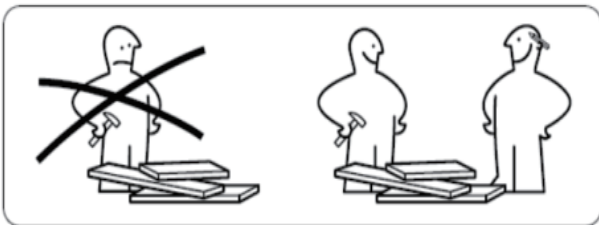

3. Unpack and assemble this unit in an spacious area, assemble the unit on top of the empty carton or carpet to prevent scratches.

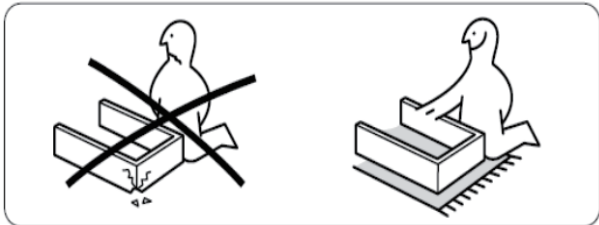

4. To avoid accidentally discarding small parts or hardware, DO NOT dispose of any contents until assembly is completed.
5. **Do not fully tighten all bolts until all parts are in place.** Failure to follow these instructions may cause the bolts to misalign during assembly.

CARE INSTRUCTIONS



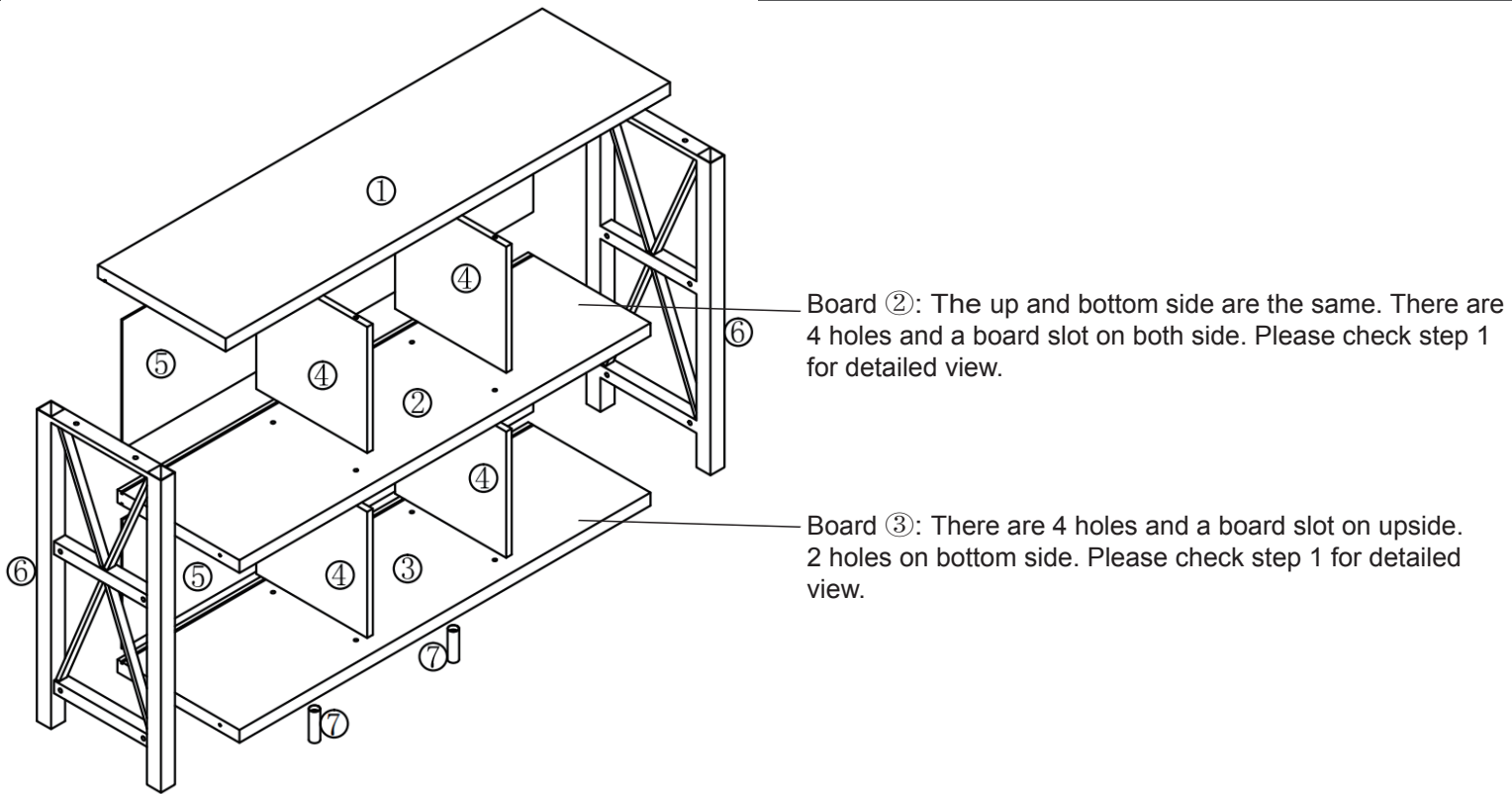

- (1) Hardware may loosen overtime. Periodically check that all connections are tight.
- (2) Wipe with a soft, dry cloth. To protect finish, avoid the use of chemicals and household cleaners.
- (3) All hot serving dishes should be placed on a pad.
- (4) Any liquid spilled onto the furniture should be cleaned up immediately with a dry cloth.

Exploded Drawing

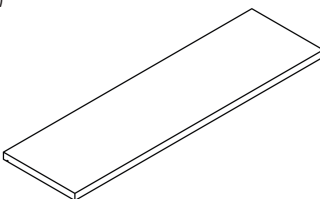
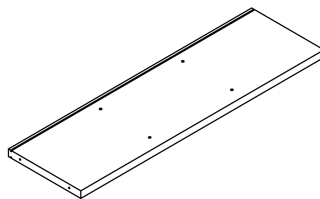
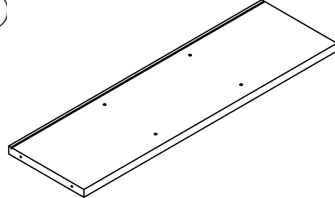
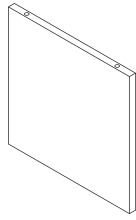
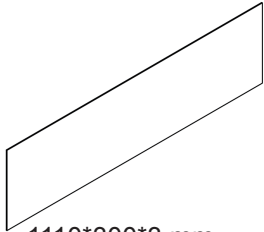
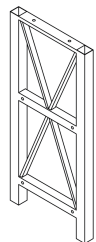
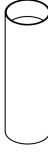
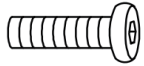

Parts & Hardwares

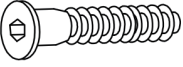
We've provided extra hardware for your replacement in case hardware missing during transportation or assembling.

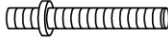
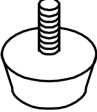
 <p>① 1200*345*30 mm (Longest one)</p> <p>Table Top 1 PC</p>	 <p>② 1110*330*30 mm</p> <p>Mid-Shelf 1 PC</p>	 <p>③ 1110*330*30 mm</p> <p>Bottom Shelf 1 PC</p>	 <p>④ 295*306*15 mm</p> <p>Divider 4 PCS</p>	
 <p>⑤ 1110*300*3 mm</p> <p>Back Panel 2 PCS</p>	 <p>⑥</p> <p>Metal Leg 2 PCS</p>	 <p>⑦</p> <p>Round Support Leg 2 PCS</p>	<p>A</p>  <p>M6x28mm Allen Bolt 4 pcs</p>	
<p>B</p>  <p>Φ8*30 mm Wood Dowel 16 pcs</p>	<p>C</p>  <p>Φ7*60 mm Self Tapping Screw 8 pcs</p>	<p>D</p>  <p>Allen key 1 pcs</p>	<p>E</p>  <p>M6x35 mm Double End Screw 2 pcs</p>	<p>F</p>  <p>M6x20 mm Adjust Leveler 2 pcs</p>

Step 1

Important Note: To avoid incorrect assembly, please follow our steps strictly.

✚ Distinguish table top (①), mid-shelf (②), bottom shelf (③) first. We've stuck labels on each board, but some of labels may fall off when unpack the package. Below is another way to distinguish table top (①), mid-shelf (②), bottom shelf (③).

Table top ①

1200*345*30 mm
(Longest one)

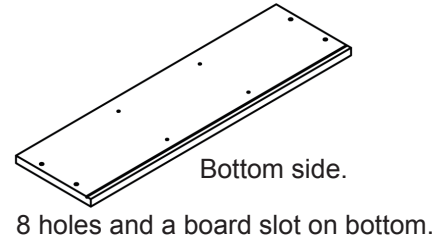
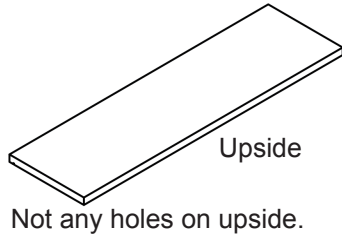

Mid-shelf ②

1110*330*30 mm

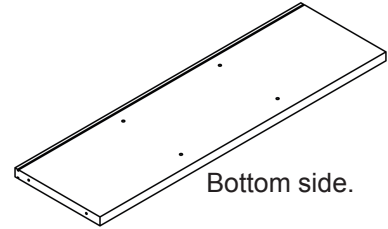
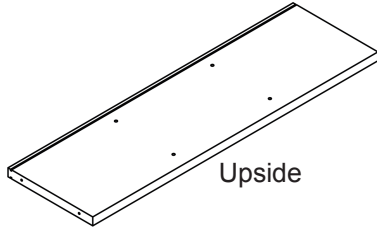

Upside and bottom side are the same. There are 4 holes and a board slot on each side.

Bottom-shelf ③

1110*330*30 mm

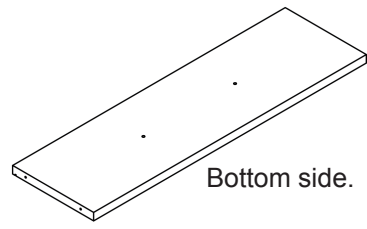
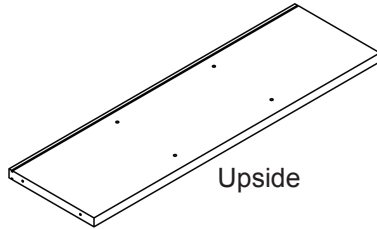

Step 2

Important Note: DO NOT fully tighten all allen bolt at this step. To avoid incorrect assembly, please follow our steps.

✚ Attached metal leg frame (⑥) to the table top (①). IMPORTANT NOTE: Put uneven side outward. Flat side inward. Fix by using 2 pcs allen bolts (A) and allen key (D). DO NOT TIGHTEN COMPLETELY. Stop when you feel you are adding force to tighten the bolt.

IMPORTANT NOTE

Put uneven side outward.
Flat side inward.

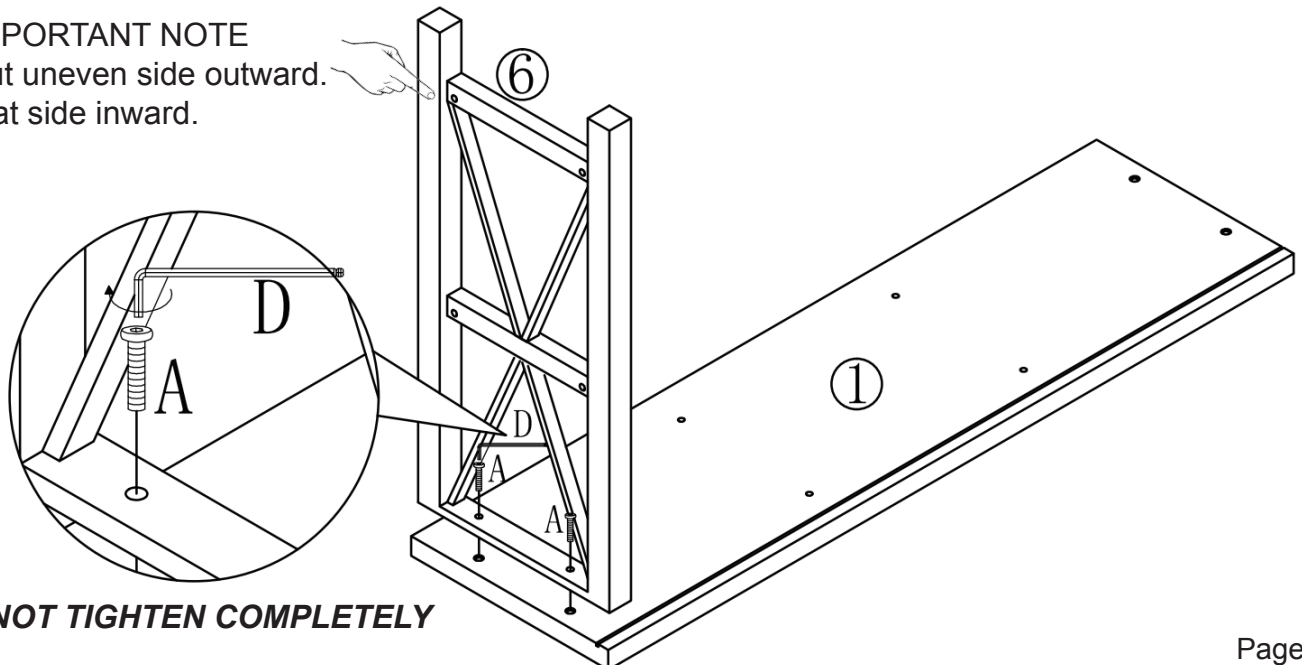

DO NOT TIGHTEN COMPLETELY

Step 3

Important Note: To avoid incorrect assembly, please follow our steps strictly.

✚ Insert 4 pcs Wood Dowel (B) to the bottom of table top (①).

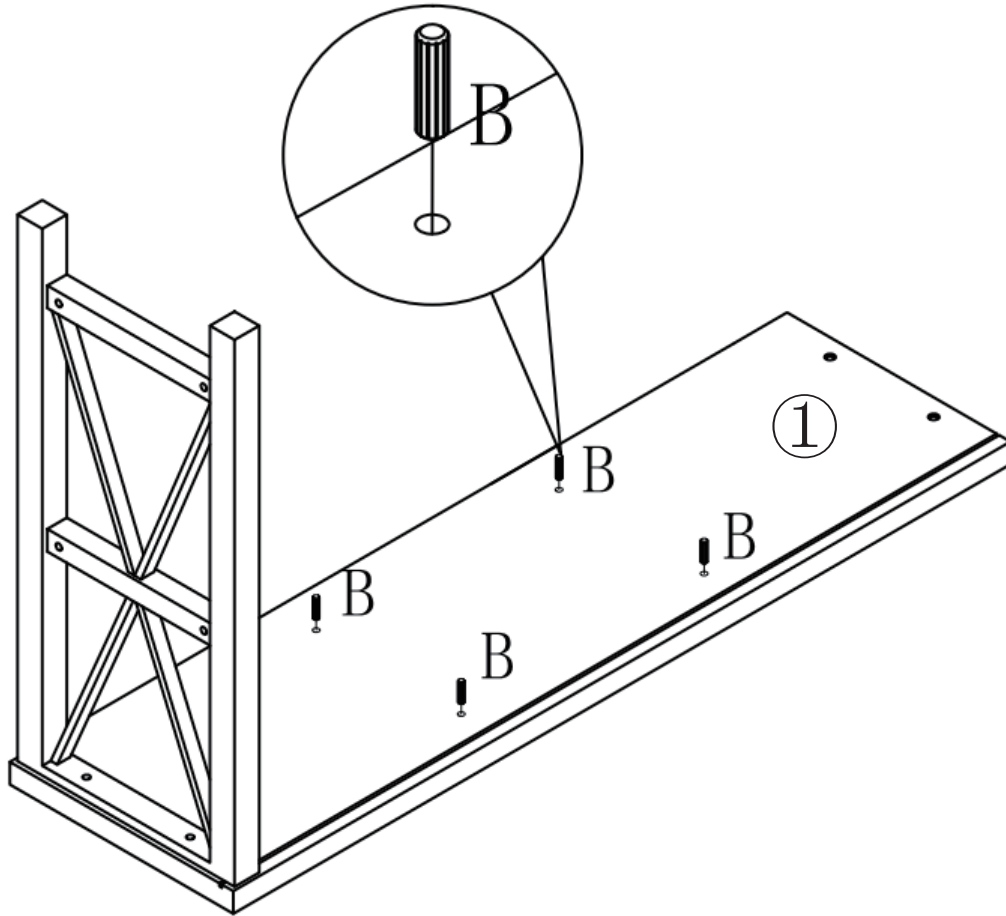

Step 4

Important Note: To avoid incorrect assembly, please follow our steps strictly.

✚ Attached 2 pcs divider (④) to the bottom of table top (①).

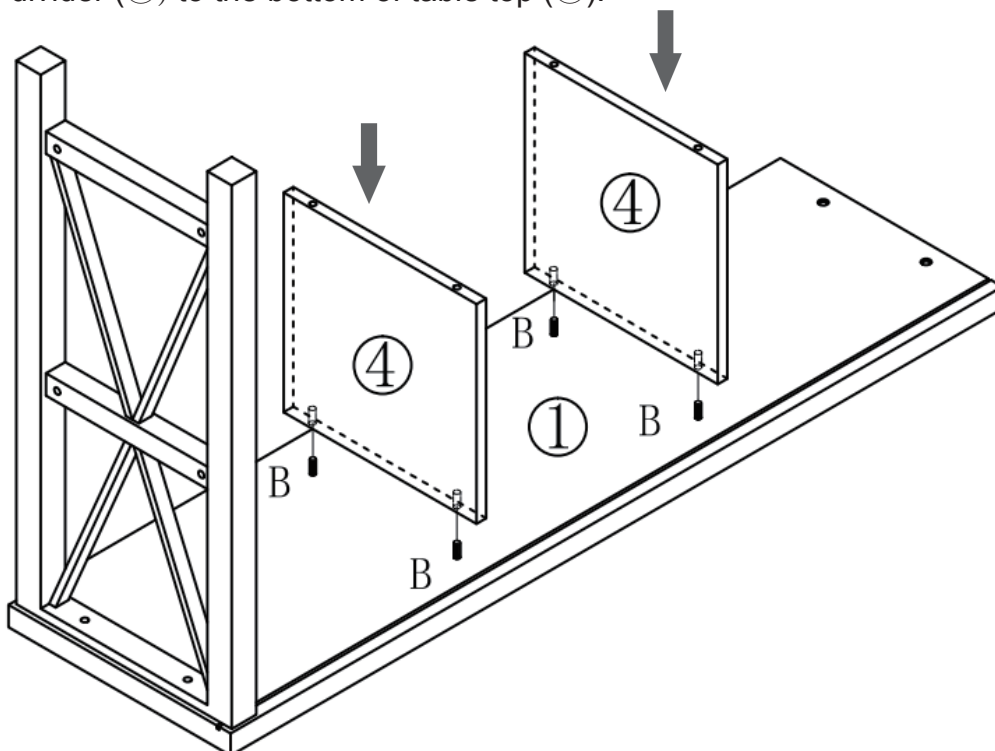

Step 5

Important Note: To avoid incorrect assembly, please follow our steps strictly.

✚ Insert 4 pcs Wood Dowel (B) to the 2 pcs divider (④) .

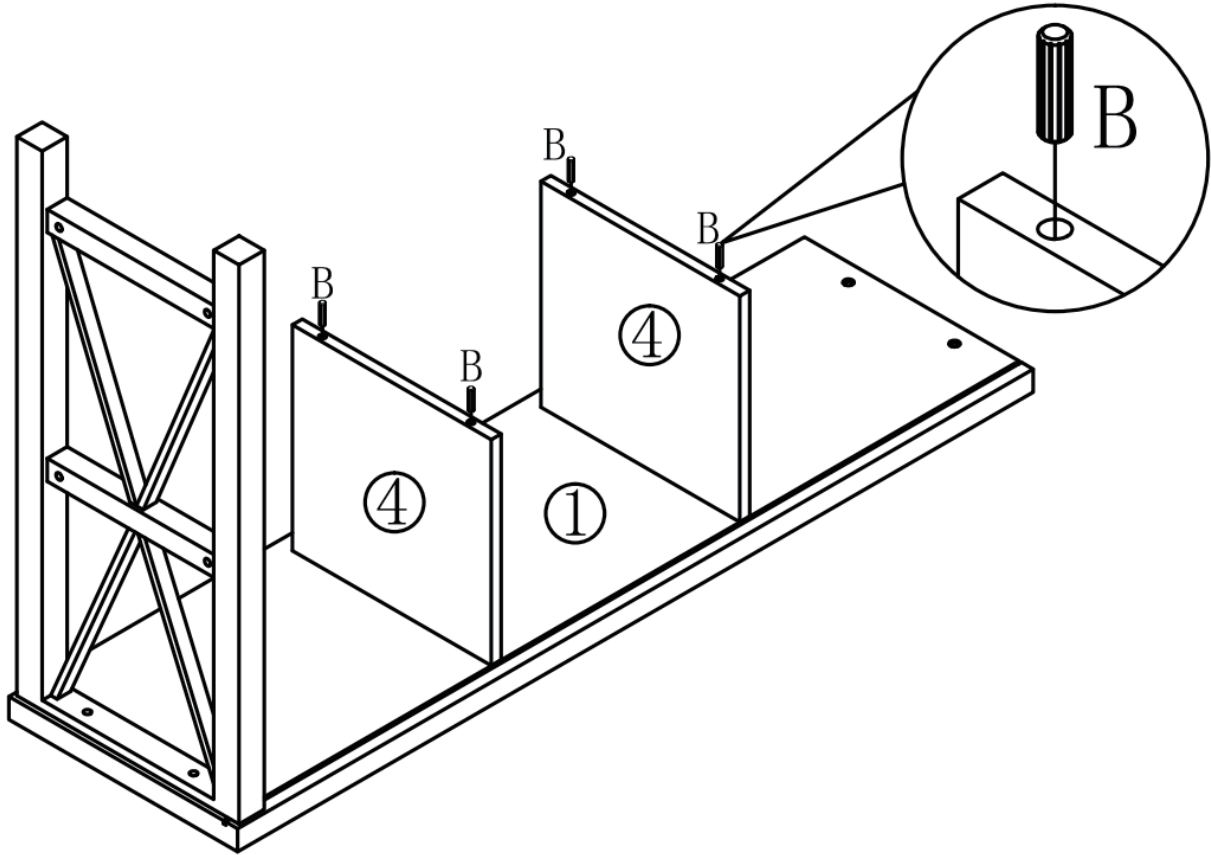

Step 6

Important Note: DO NOT fully tighten self tapping screw at this step. To avoid incorrect assembly, please follow our steps.

✚ Attached Mid-Shelf (②) to the divider (④), then attached Mid-Shelf (②) to metal legs (⑥) fix by using 2 pcs self tapping screw (C) and allen key (D). DO NOT TIGHTEN COMPLETELY. Stop when you feel you are adding force to tighten the screw.

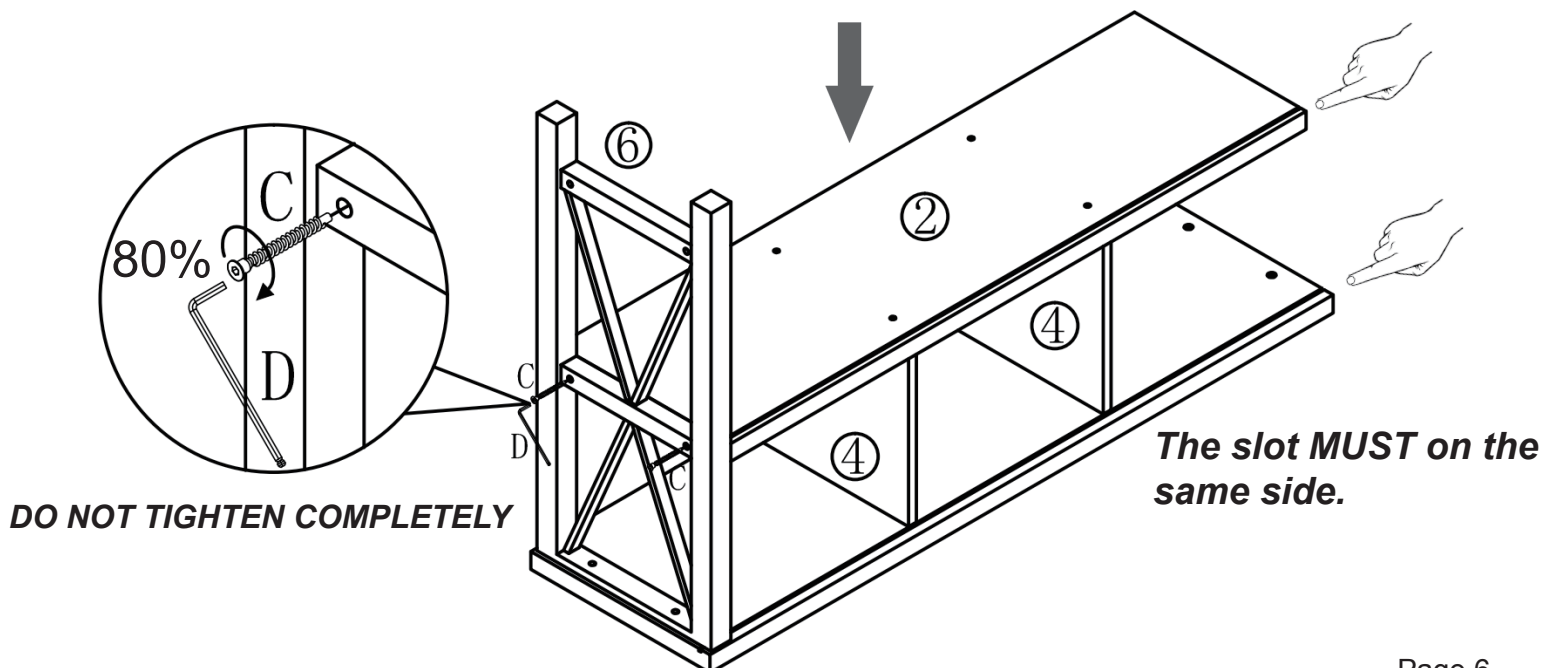

Step 7

Important Note: To avoid incorrect assembly, please follow our steps strictly.

✚ Insert 1 pc back panel (⑤) to table top (①) and mid-shelf (②) from right side.

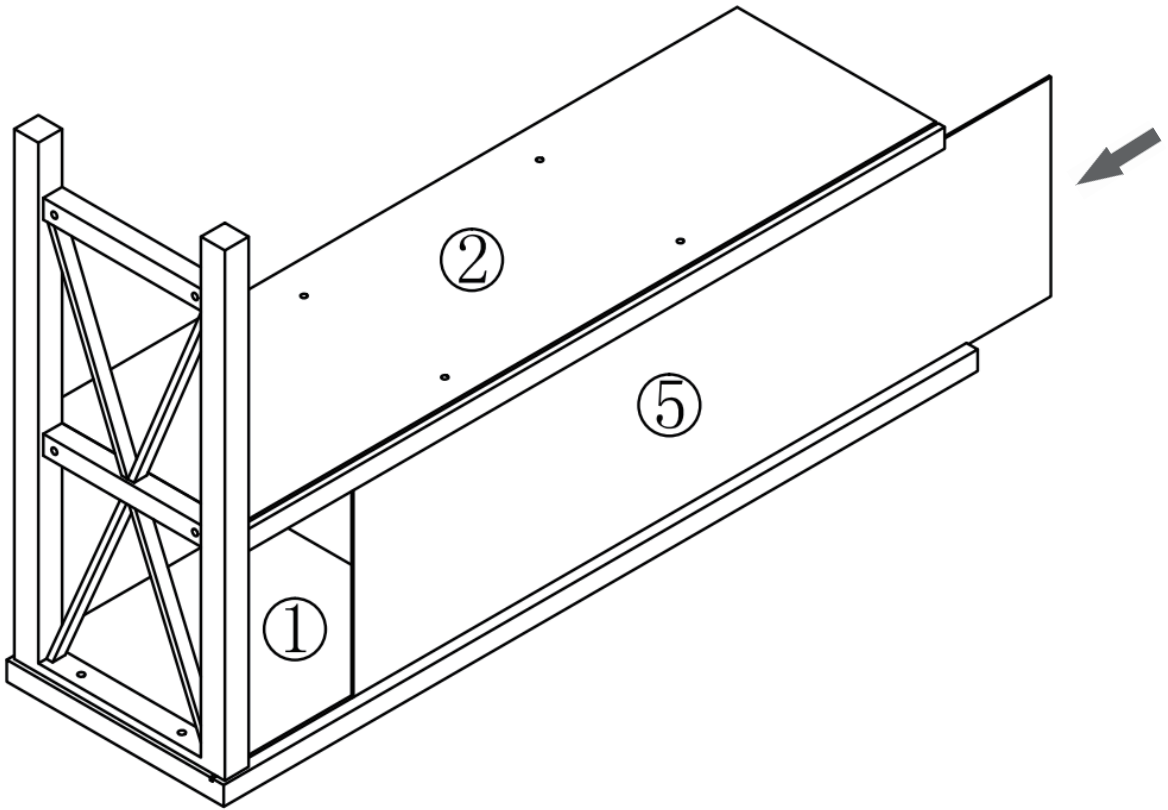

Step 8

Important Note: To avoid incorrect assembly, please follow our steps strictly.

✚ Insert 8 pcs Wood Dowel (B) to 2 pcs divider (④), then attached 2 pcs divider (④) to Mid-Shelf (②).

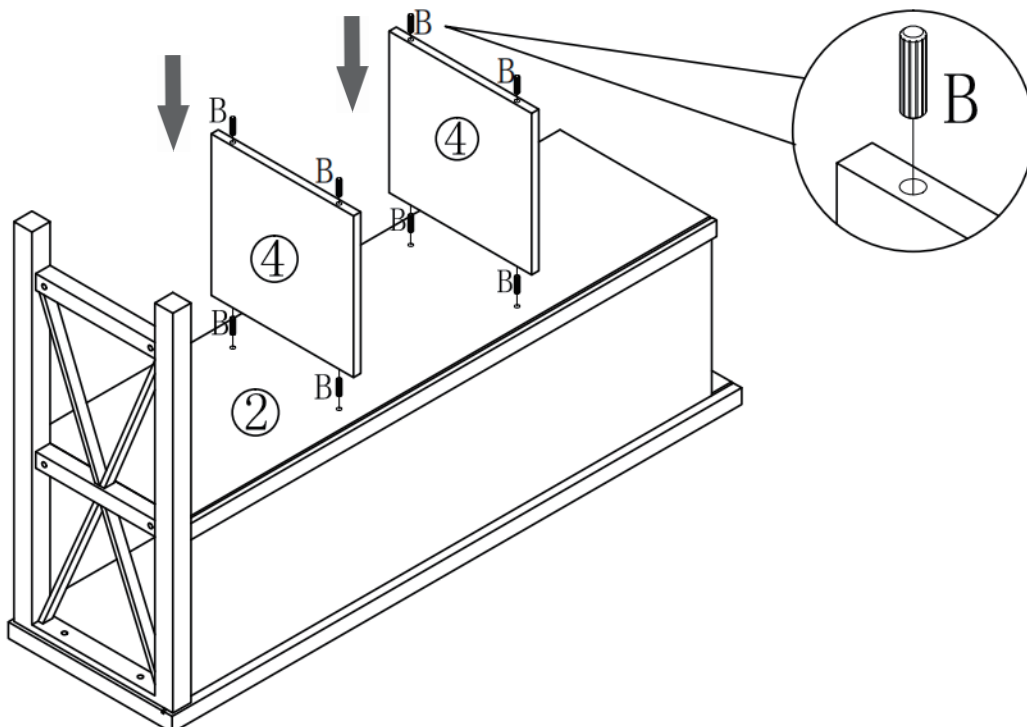

Step 9

Important Note: DO NOT fully tighten self tapping screw at this step. To avoid incorrect assembly, please follow our steps.

✚ Attached Bottom-Shelf (③) to the divider (④), then attached Bottom Shelf (③) to metal legs (⑥) fix by using 2 pcs self tapping screw (C) and allen key (D). DO NOT TIGHTEN COMPLETELY. Stop when you feel you are adding force to tighten the screw.

DO NOT TIGHTEN COMPLETELY

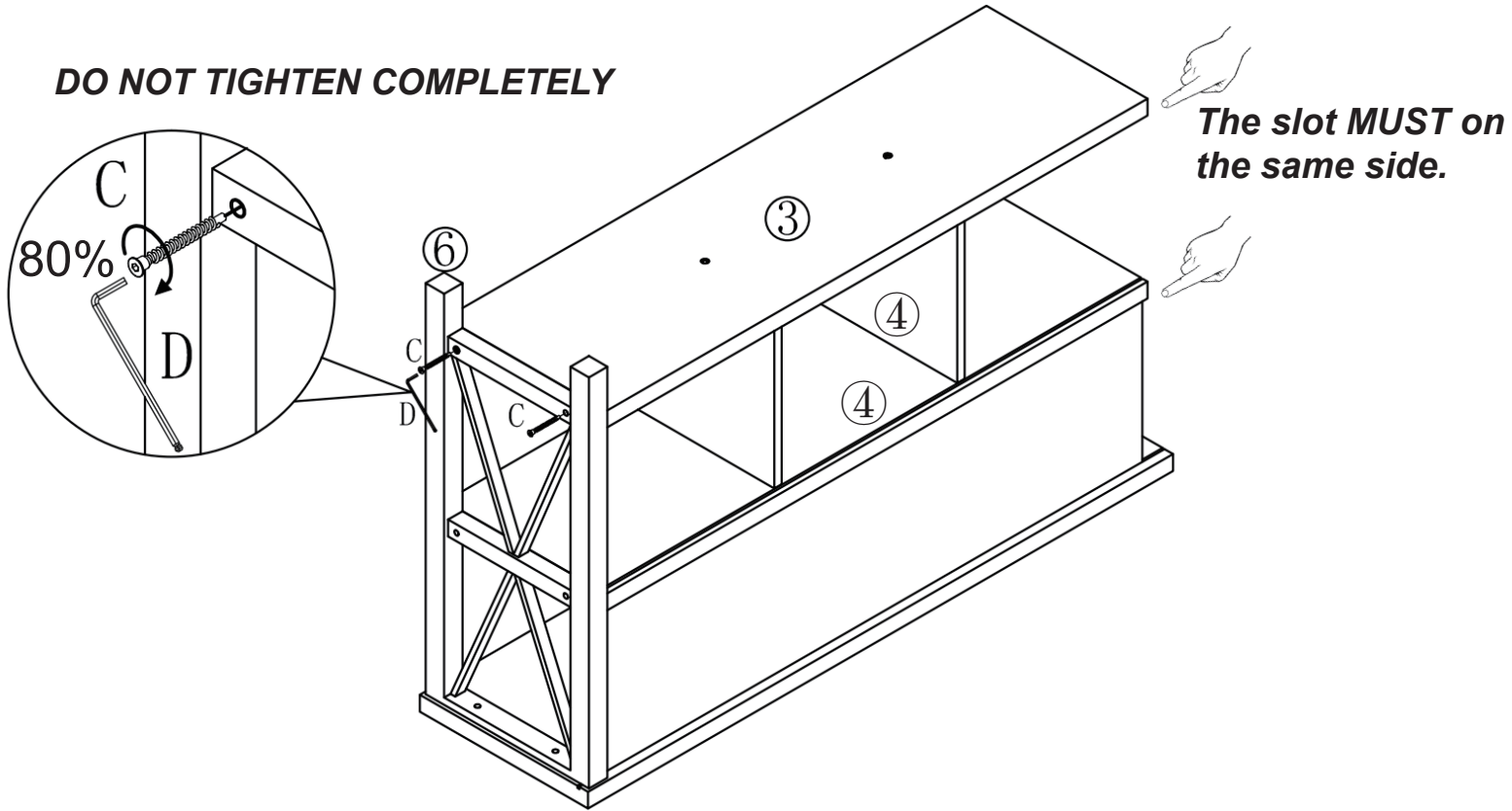

Step 10

Important Note: To avoid incorrect assembly, please follow our steps strictly.

✚ Insert 1 pc back panel (⑤) among bottom shelf (③) and mid-shelf (②) from right side.

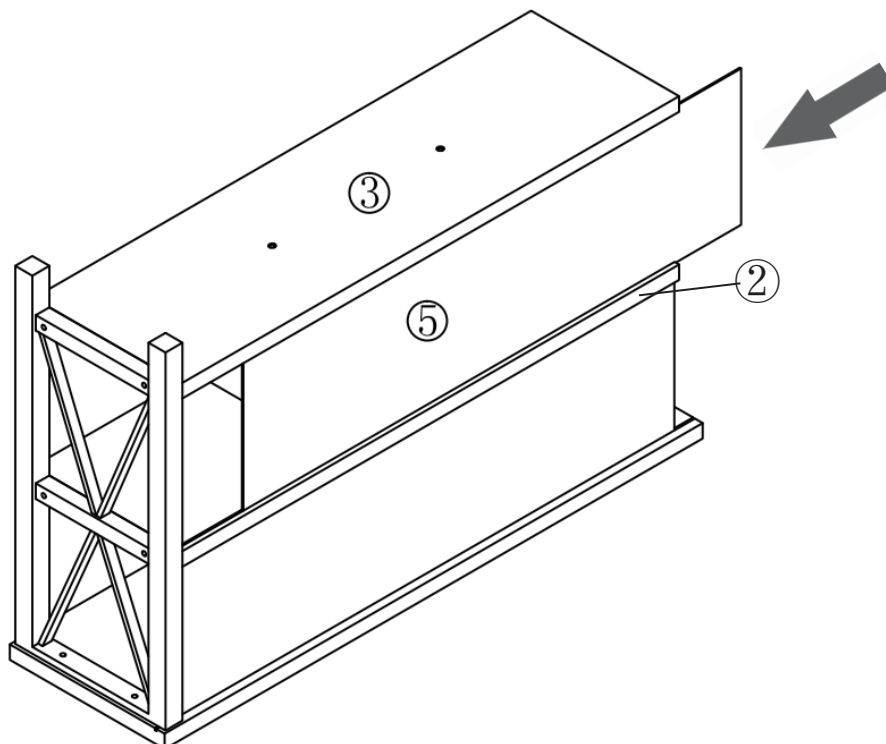

Step 11

Important Note: To avoid incorrect assembly, please follow our steps strictly.

✚ Attach metal leg frame (⑥) to the table top (①), fix by using 2 pcs allen bolts (A) and allen key (D). DO NOT TIGHTEN COMPLETELY. Then fix metal leg frame (⑥) to mid-shelf (②) and bottom shelf (③), fasten by using 4 pcs self tapping screw (C) and allen key (D). After all parts are in place, then you can fully tighten all the bolts and screws (A & C).

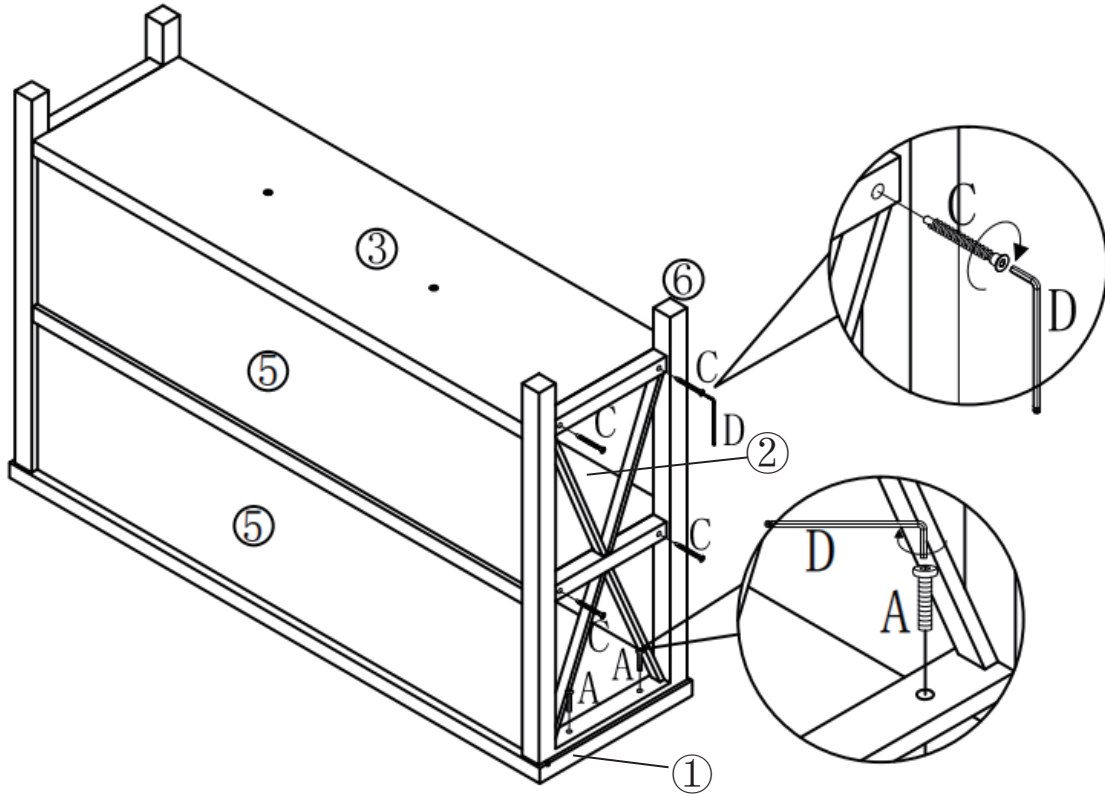

Step 12

Important Note: To avoid incorrect assembly, please follow our steps strictly.

✚ Clockwise rotate 2 pcs double end screw (E) into bottom shelf (③).

Important Note:
Short-head side downward.

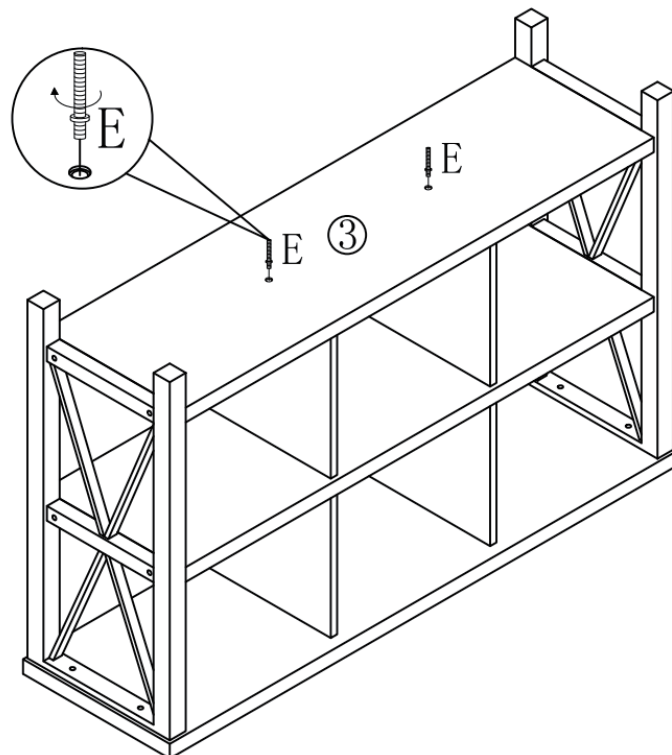
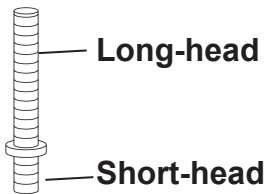

Step 13

Important Note: To avoid incorrect assembly, please follow our steps strictly.

⚠️ Clockwise rotate 2 pcs round support legs (7) to the screw (E). Then attached 2 pcs adjustable levelers (F) to the round support legs (7) as needed for uneven floor.

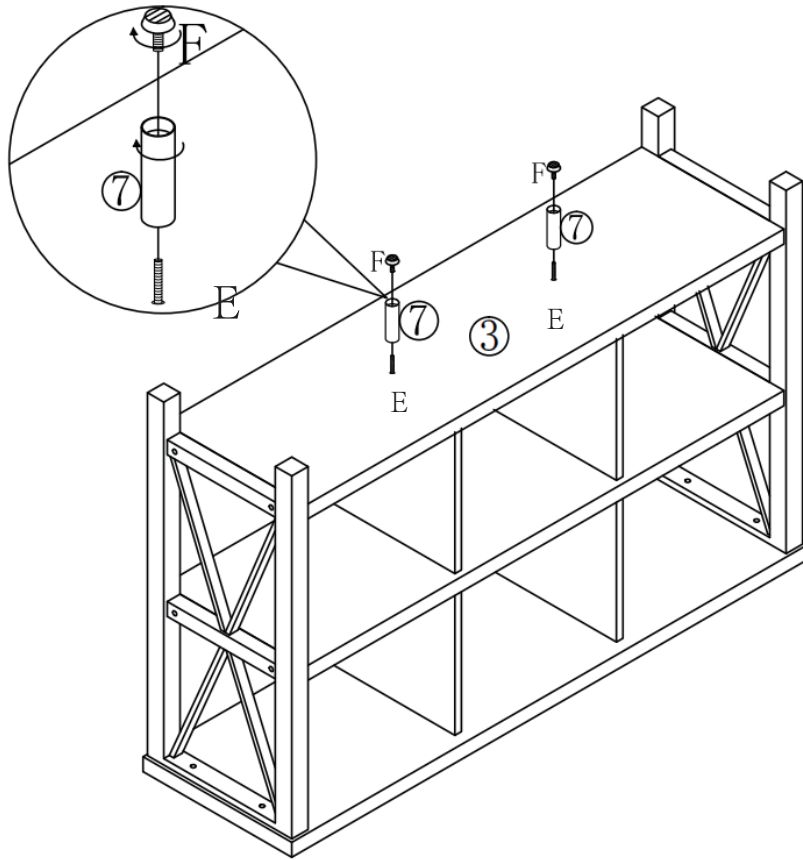

Step 14

Important Note: To avoid incorrect assembly, please follow our steps strictly.

⚠️ Flip bookcase up. Contrarotate 2 pcs adjustable leveler (F) until the leveler bottom is against the surface of the floor.

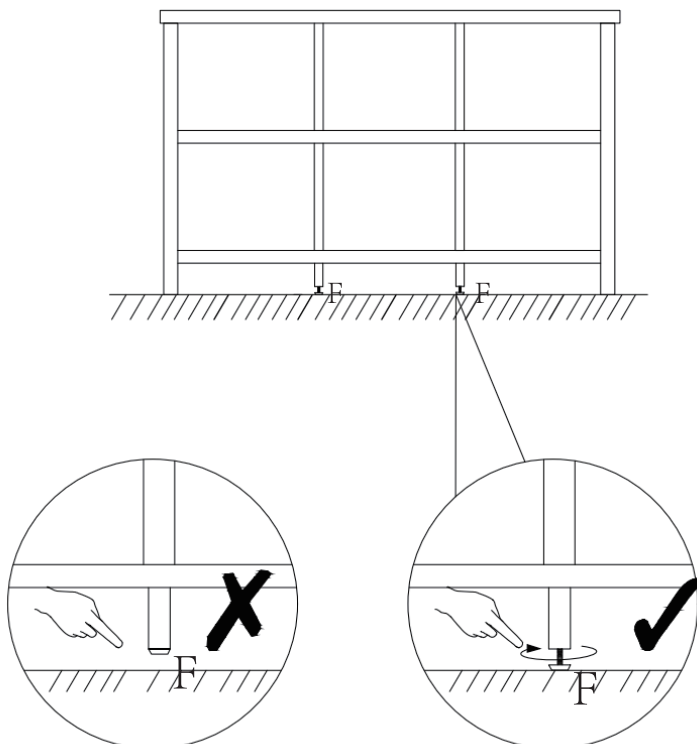

NOTE: Contrarotate 2 pcs adjustable leveler (F) until the leveler bottom is against the surface of the floor.

Important note: If you find the holes do not align together, you can loosen all the screws, and adjust the holes slightly. After all the holes were aligned together, you can fully tighten all the screws.

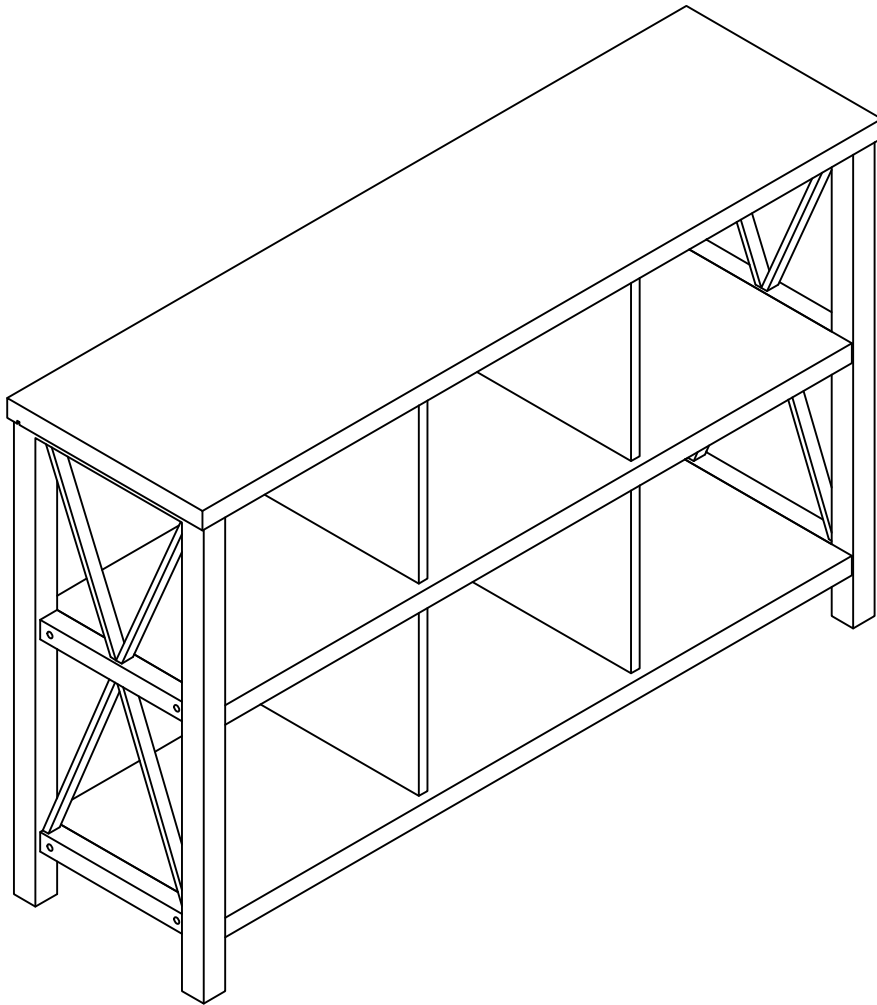

Finish Assembly

📌 If you have any questions with our products, please do not hesitate to contact with us at any time.