

# Rectangle Coffee Table

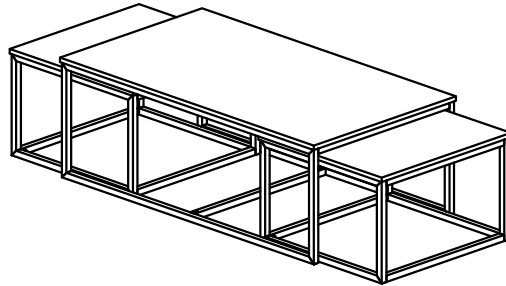

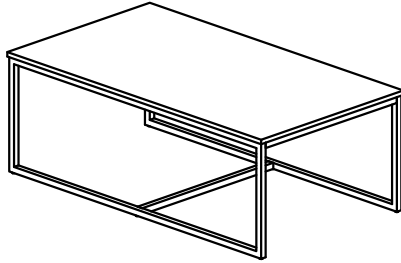



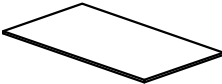
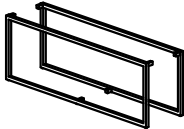

Note: Illustration shown with optional Nesting Tables underneath.

Thank you for purchasing the Rectangle Coffee Table. We have found it helpful to have a second person present during the assembly process.

## Rectangle Coffee Table Assembly Instructions

### Parts

NO.	DRAWING	DESCRIPTION	QTY
A		TABLE TOP	1
B		BIG SIDE FRAME	2
C		UPPER STRETCHER	2
D		LOWER STRETCHER	1

NO.	DRAWING	DESCRIPTION	QTY
E		M6x40MM BOLT	14
F		M6x20MM BOLT	6
G		FLAT WASHER	20
H		ALLEN KEY	1

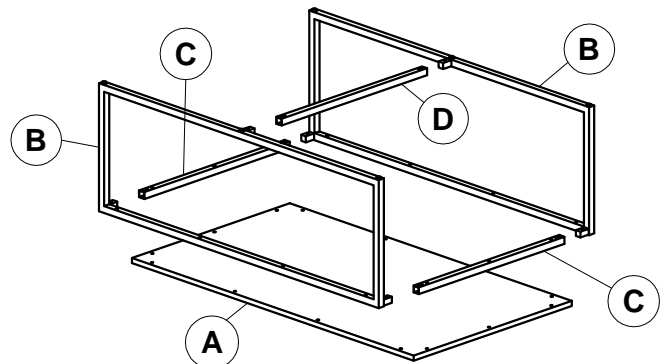

### Step 1

Read through these instructions thoroughly before beginning assembly. We have found this to be of great value when assembling this product.

## Step 2

Remove all parts and hardware from packing material. Wooden pieces should be placed on a non abrasive surface to prevent damage to the finish

---

## Step 3

Attach leg stretchers (C&D) to Side Frames Assembly (B) using 6-M6x20MM Hex Bolts (F) and Flat Washer (G). NOTE: DO NOT TIGHTEN FIRMLY AT THIS TIME!

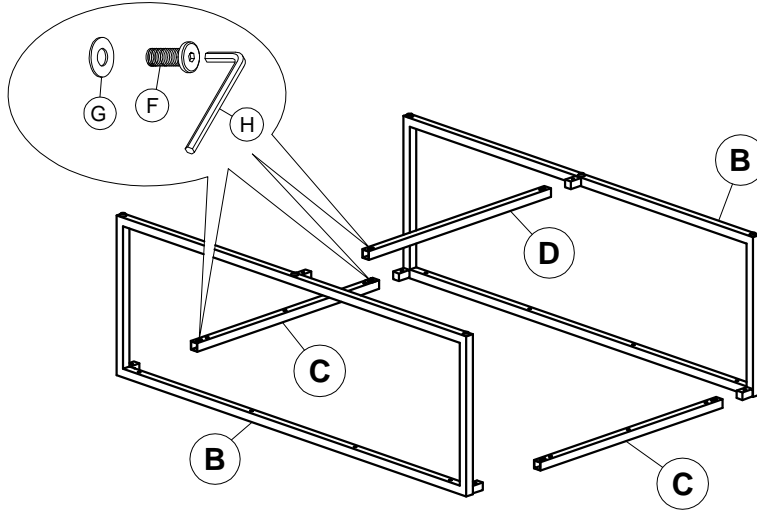

## Step 4

Lay Table Top Assembly (A) upside down on a non abrasive surface. Attach Leg-Frame Assembly using 14-M6x40MM Hex Bolts (E) and Flat Washer (G). NOTE: TIGHTEN ALL BOLTS AT THIS TIME!

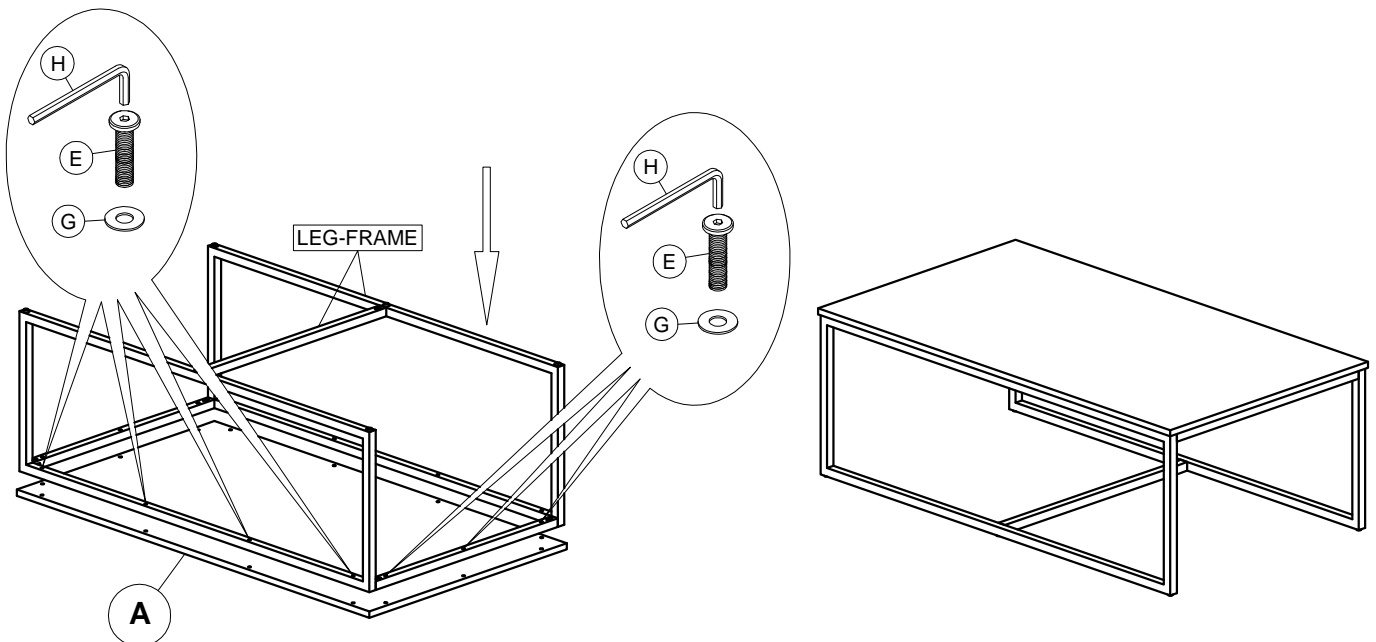

## CARE

Clean with a non abrasive cloth using a mild soap. Make sure to wipe dry.

---