

# ASSEMBLY INSTRUCTIONS

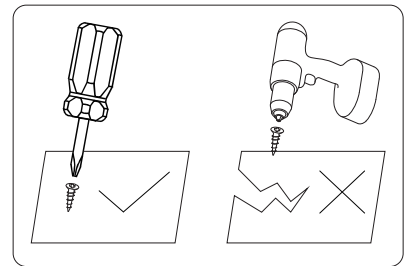
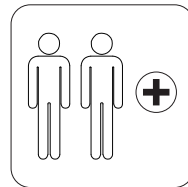
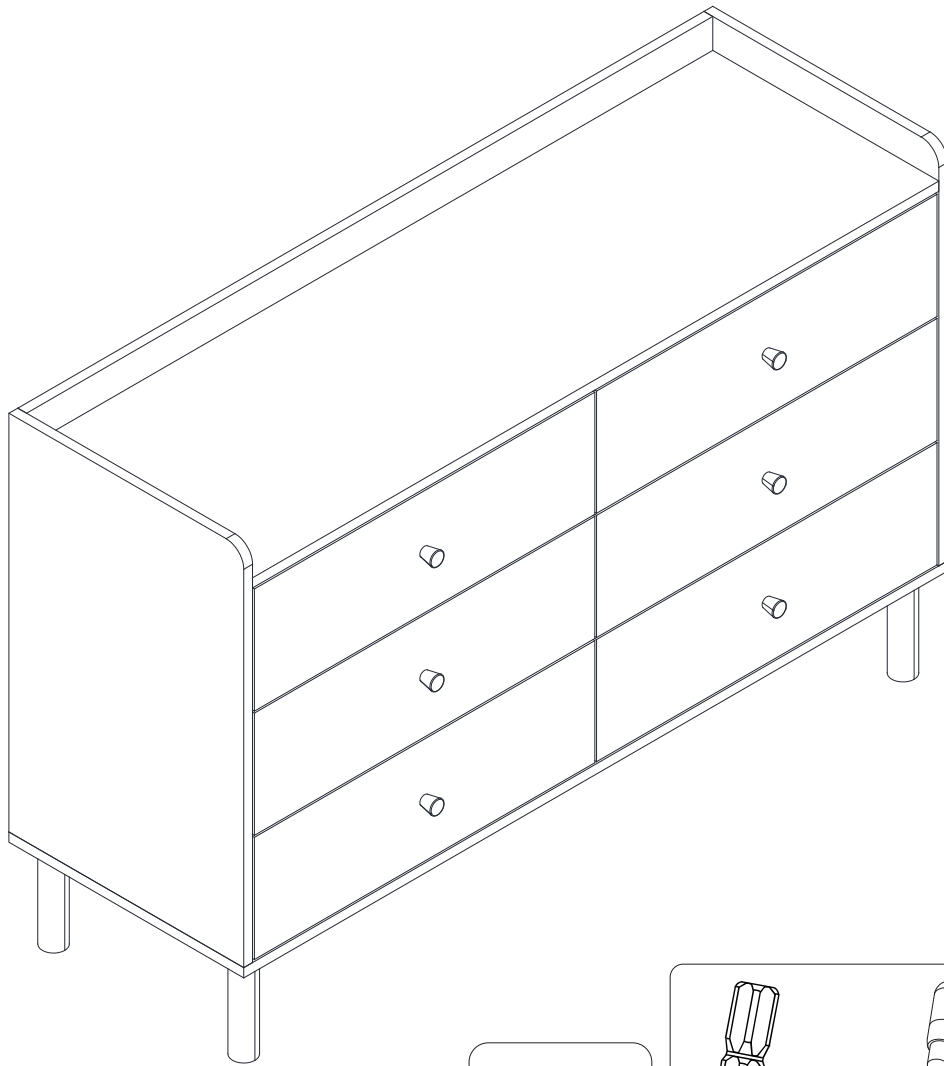

**Tools Recommended**

# IMPORTANT NOTICE

- This product contains small components, please ensure that they are kept away from small children.
- THIS INSTRUCTIONS CONTAINS IMPORTANT SAFETY INFORMATION. PLEASE READ BEFORE ASSEMBLY AND KEEP FOR FUTURE REFERENCE.
- Read each step carefully. It is very important that each step of instruction is performed in the correct order. If these steps are not followed in sequence, assembly difficulties will occur.
- Make sure all parts are included. Most parts are labelled or stamped on the raw edge.
- Work in spacious area, preferably on a carpet, near the place the unit will be used.
- Do not use power tools to assemble your furniture. Power tools may strip or damage the parts.
- Move your new furniture carefully, with two people lift and carry the unit to it's new location.
- Never push, drag or pull your furniture (especially on carpet)





## PLEASE DO NOT RETURN PRODUCT TO US IMMEDIATELY









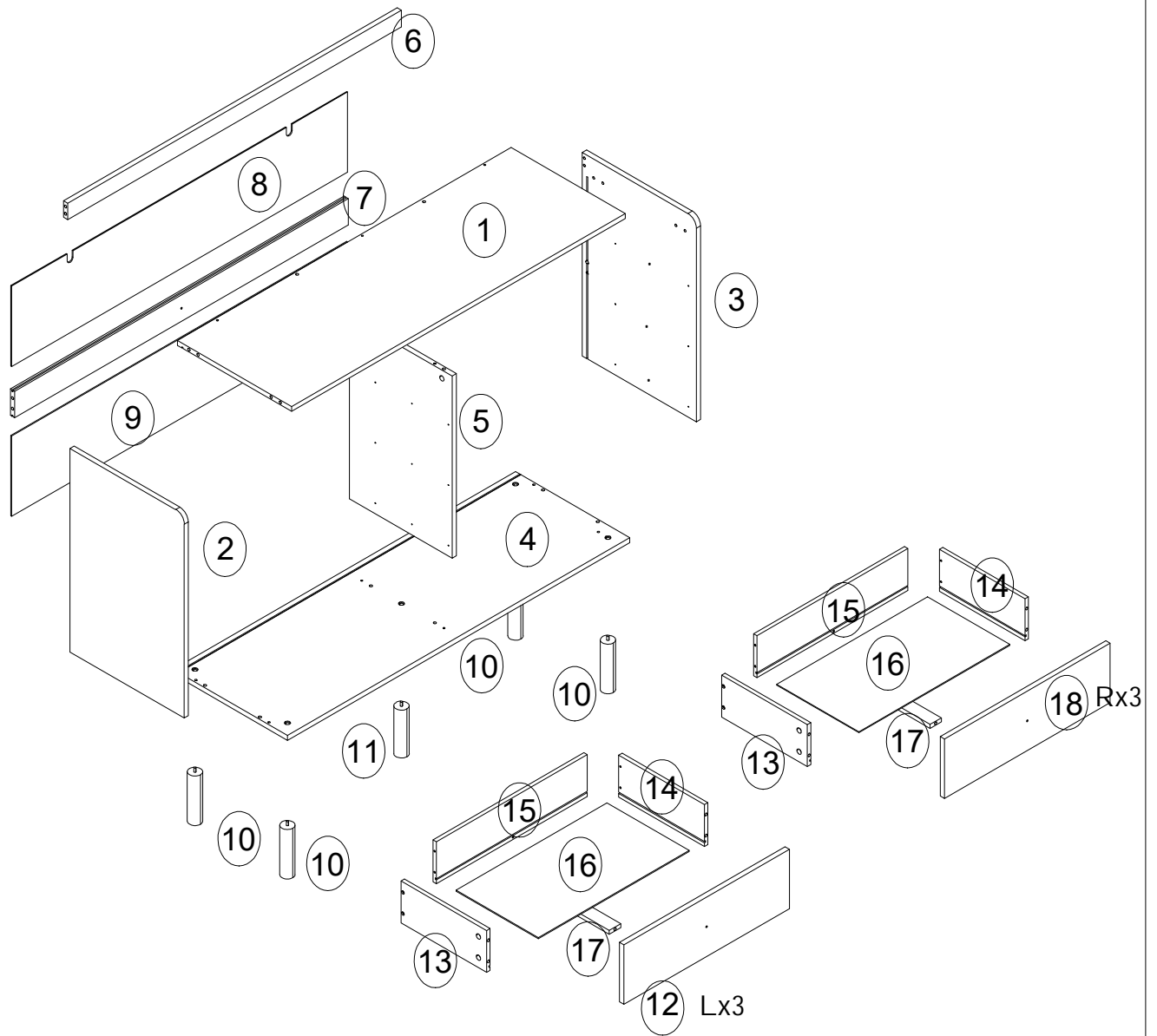







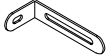

If a part is missing or damaged, email our customer service. We will gladly ship your replacement parts FREE of charge.

Need Parts or Assistance? Email us at [cs@nbrehome.com](mailto:cs@nbrehome.com)

For Prompt, reliable service, please have your assemble instruction ready.

<b>! WARNING</b>	
	<b>Children have died from furniture tipover. To reduce the risk of furniture tipover:</b> <ul style="list-style-type: none"><li>• ALWAYS install anti-tip device provided.</li><li>• NEVER put a TV on this product.</li><li>• NEVER allow children to stand, climb or hang on any drawers, doors, or shelves.</li><li>• NEVER open more than one drawer at a time.</li><li>• Place heaviest items in the lowest drawers.</li></ul>
	<p><i>This is a permanent label. Do not remove!</i></p>



<b>Ax42</b>  Ø6x35mm	<b>Bx42</b> 	<b>Cx16</b>  6x30mm	<b>Dx72</b>  3.5x12mm	<b>Ex7</b>  5x40mm	<b>Fx33</b>  4x30mm	<b>Gx12</b>  3x14mm
<b>Hx12</b> 	<b>Ix6</b> 	<b>Jx1</b> 	<b>Kx2</b> 	<b>Lx2</b>  4x12mm	<b>Mx2</b> 	<b>Nx2</b>  4x35mm
<b>Ox6</b> 	<b>CLx6</b> 	<b>CRx6</b> 	<b>DLx6</b> 	<b>DRx6</b> 		

# STEP 1

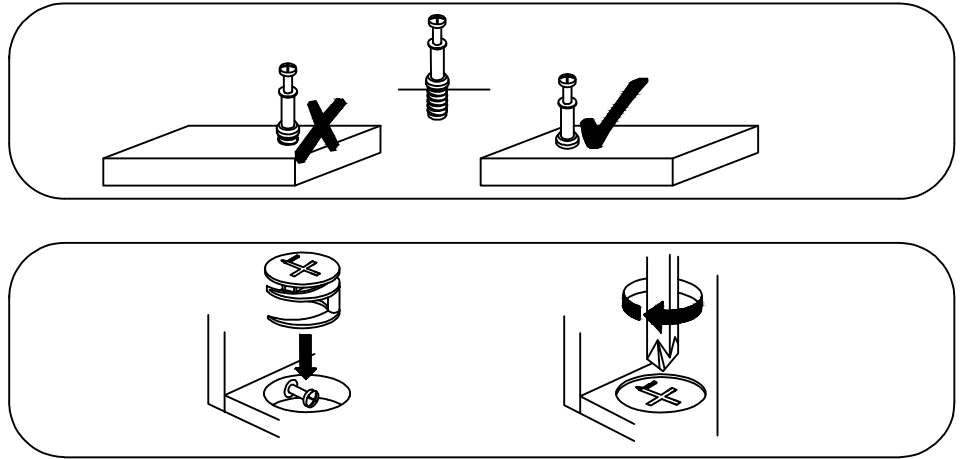

Use the screw D to install the guide rail CL on the side panel 5, and install the guide rail CR on the side panel 5. The installation position is as shown in the figure below.

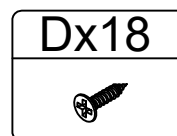
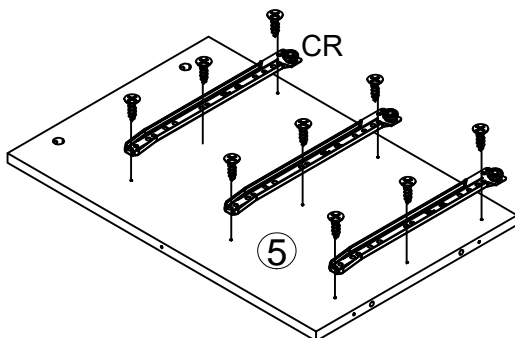
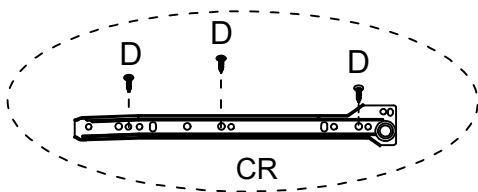
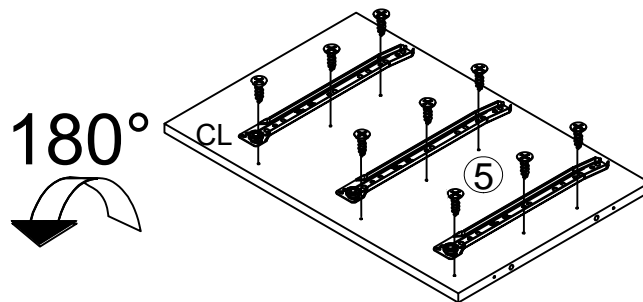
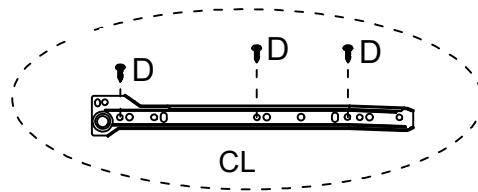

# STEP 2

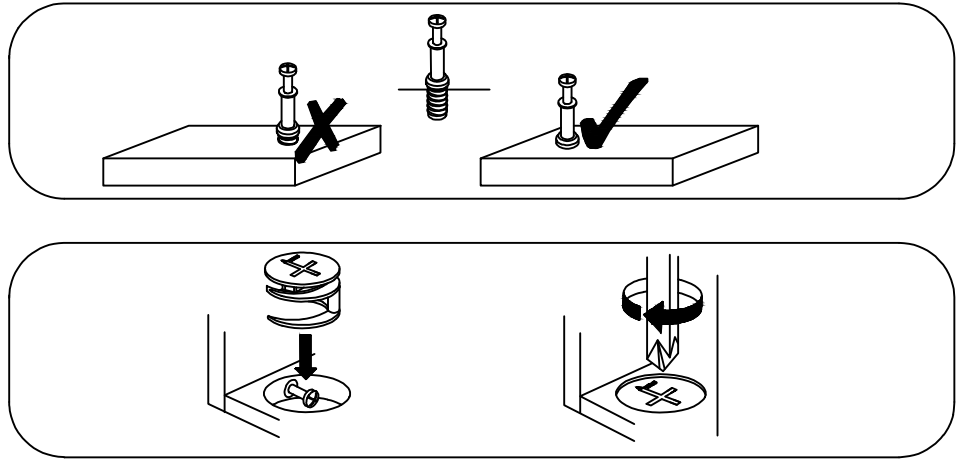

Use the screw D to install the guide rail CL on the side panel 2 , Install the screw A on the part 2.

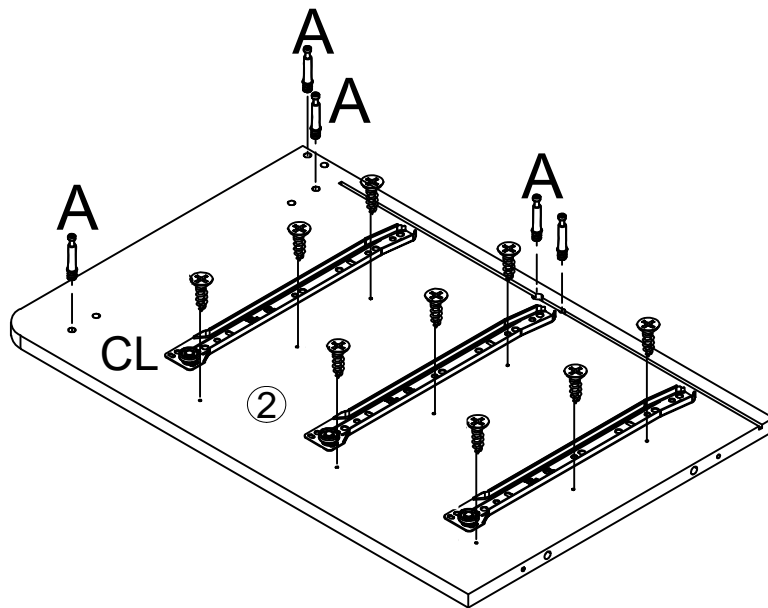
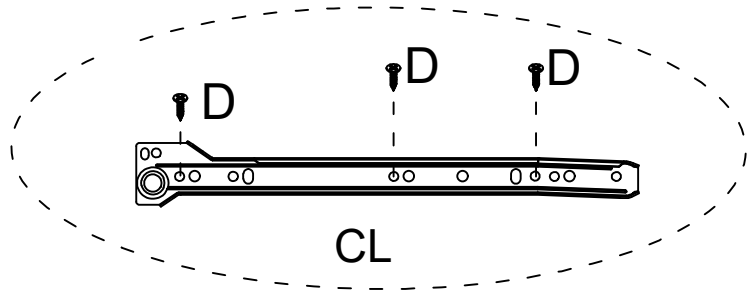

# STEP 3

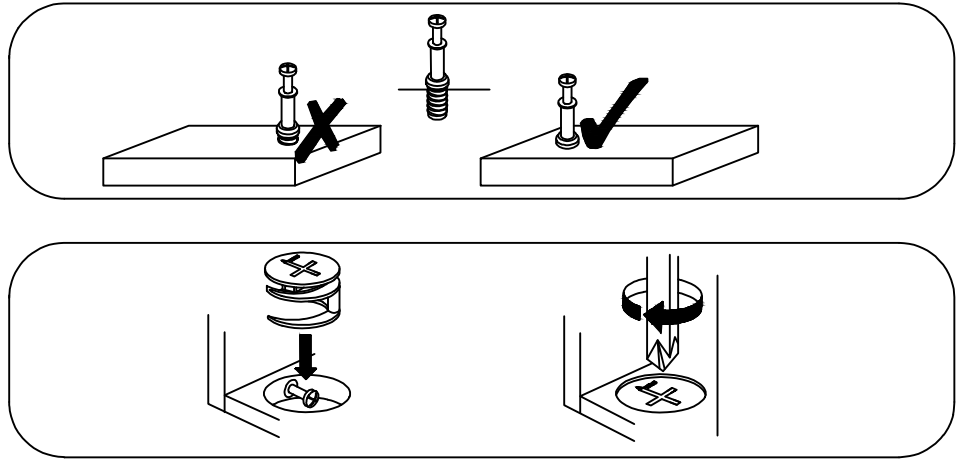

Use the screw D to install the guide rail CR on the side panel 3.  
The installation position is as shown in the figure below.

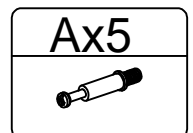
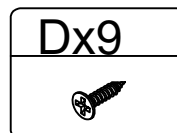
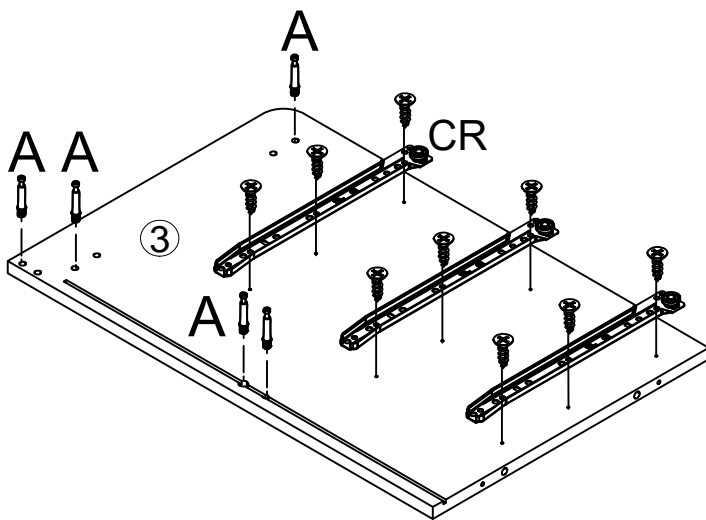
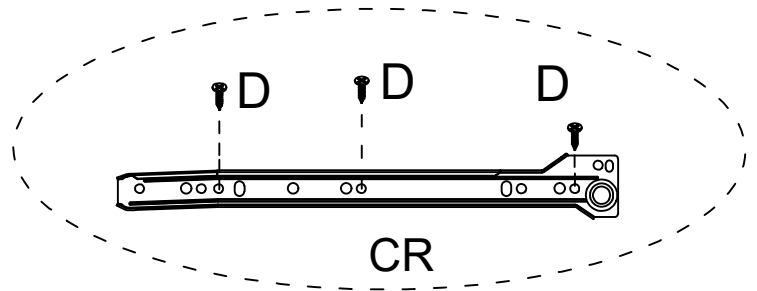

# STEP 4

Use the screw E to install the part 7 on the side panel 5,  
The installation position is as shown in the figure below.

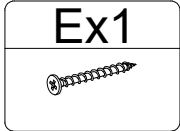
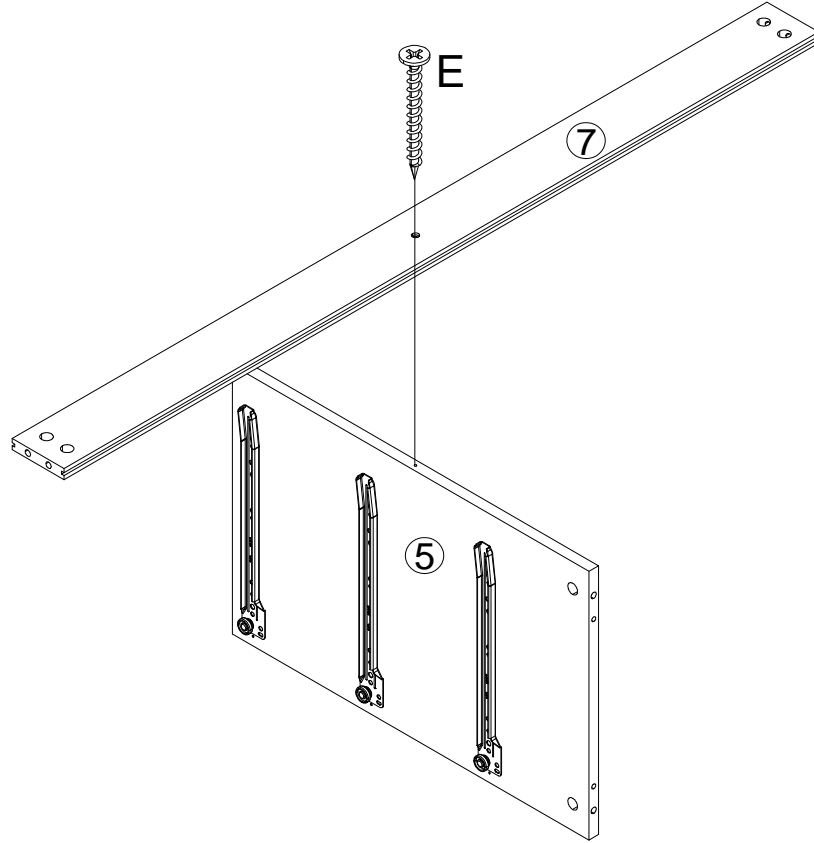

# STEP 5

Insert the dowel C into part 6 first. Assemble parts 1 and part 6 by screw F.  
Install the screw A on the part 1.

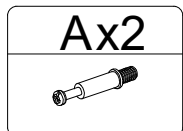
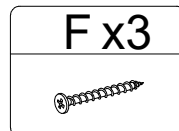
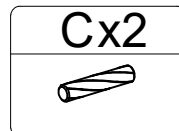
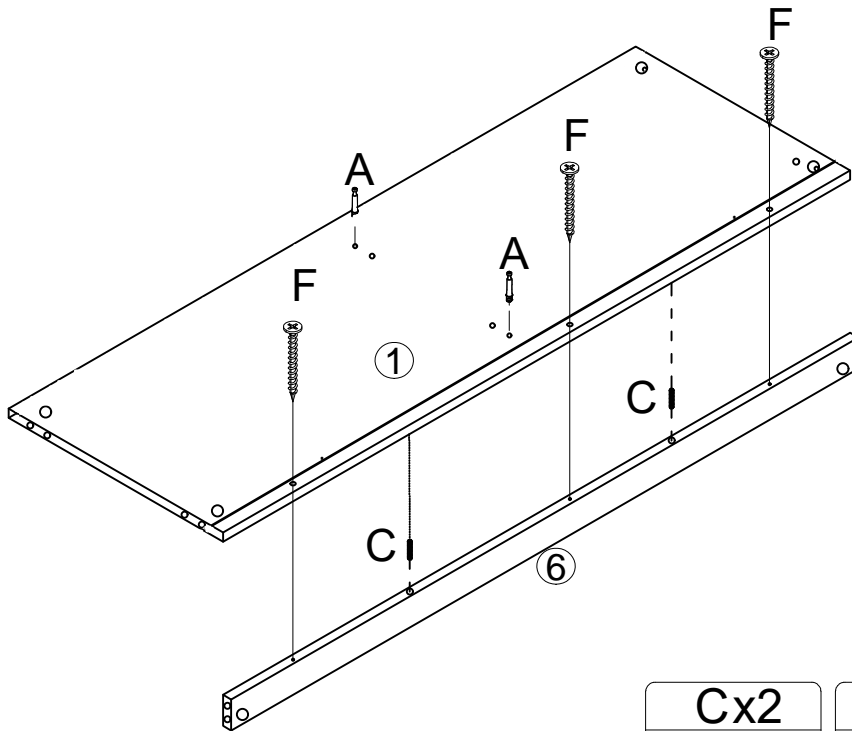

## STEP 6

Insert the dowel C into part 5 first,  
Put the eccentric B into the corresponding hold (part 5);  
and use a flat - blade screwdriver to turn it clockwise to tighten,.  
the installation position is as shown below.

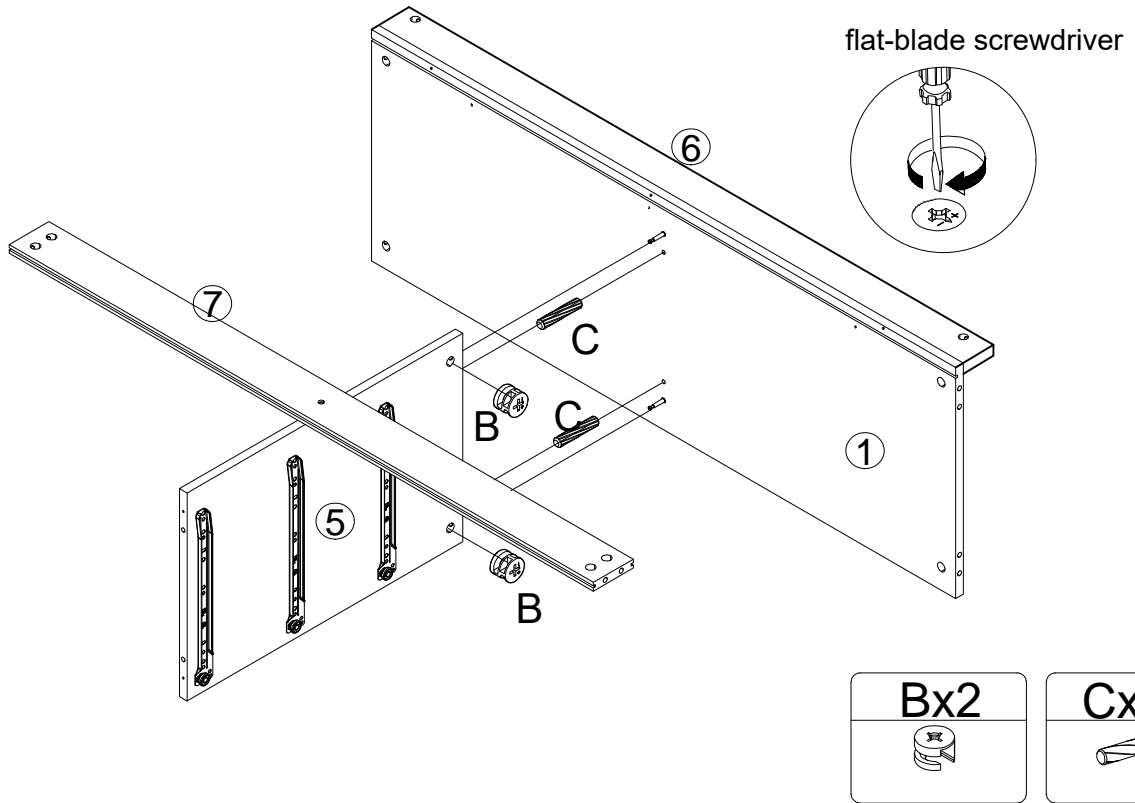

## STEP 7

Insert the dowel C into part 1 first,  
Put the eccentric B into the corresponding hold(part7;1);  
and use a flat-blade screwdriver to turn it clockwise to tighten,  
the installation position is as shown below.

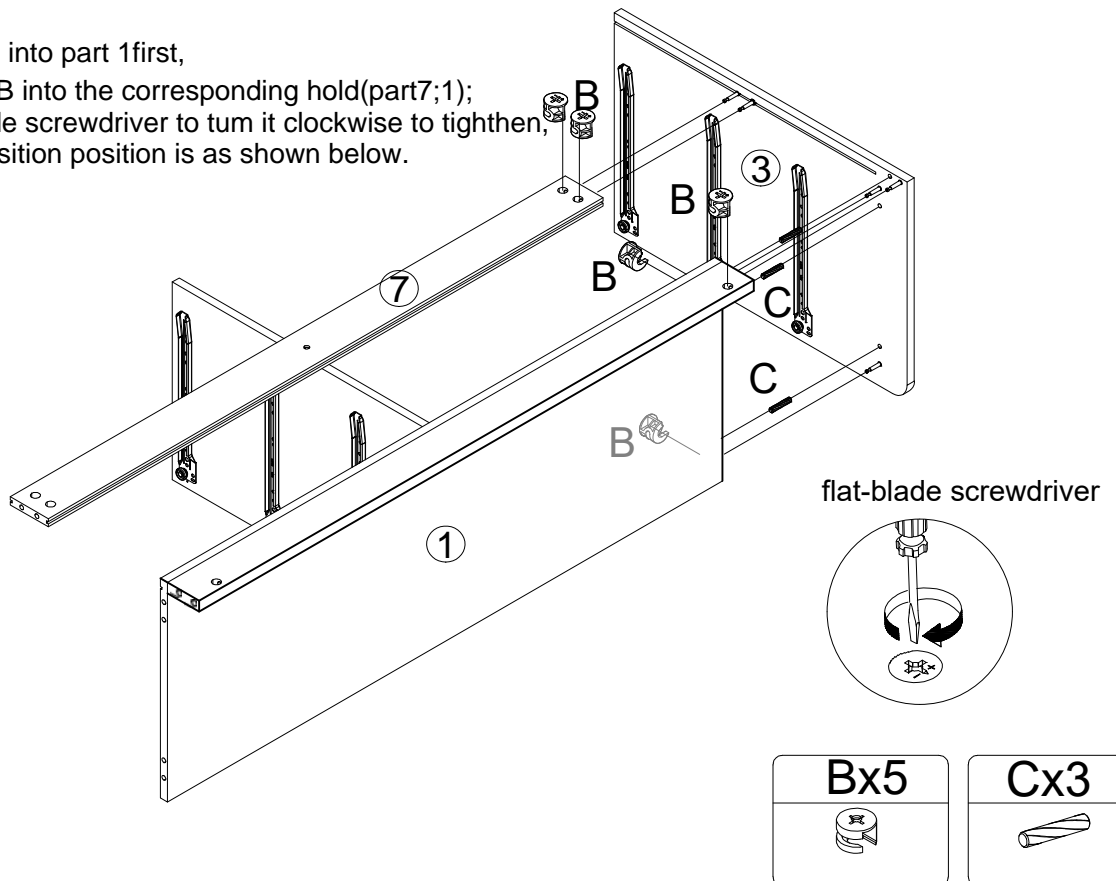

## STEP 8

Insert part 8 along the slot, the position is as shown below.

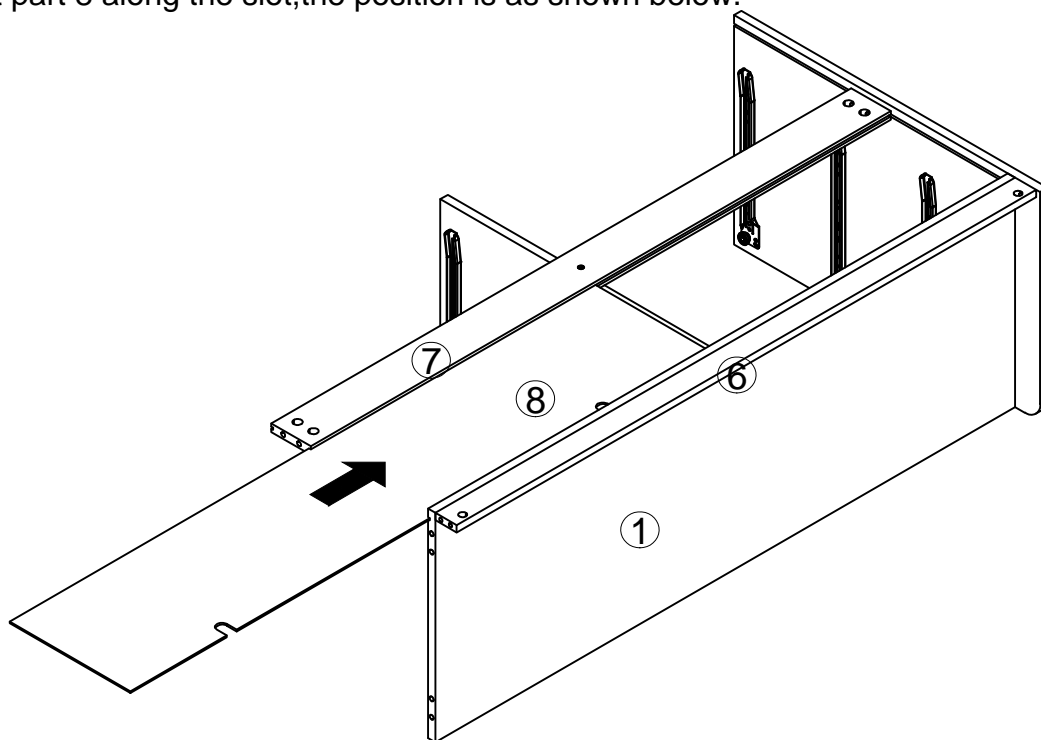

## STEP 9

Insert the dowel C into part 1 first.  
Put the eccentric B into the correspondin hold,  
and use a flat-blade screwdriver to turn it clockwise to tighten,  
the installation position is as shown below.

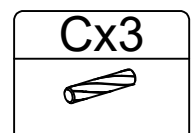
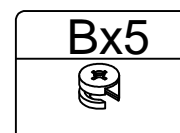
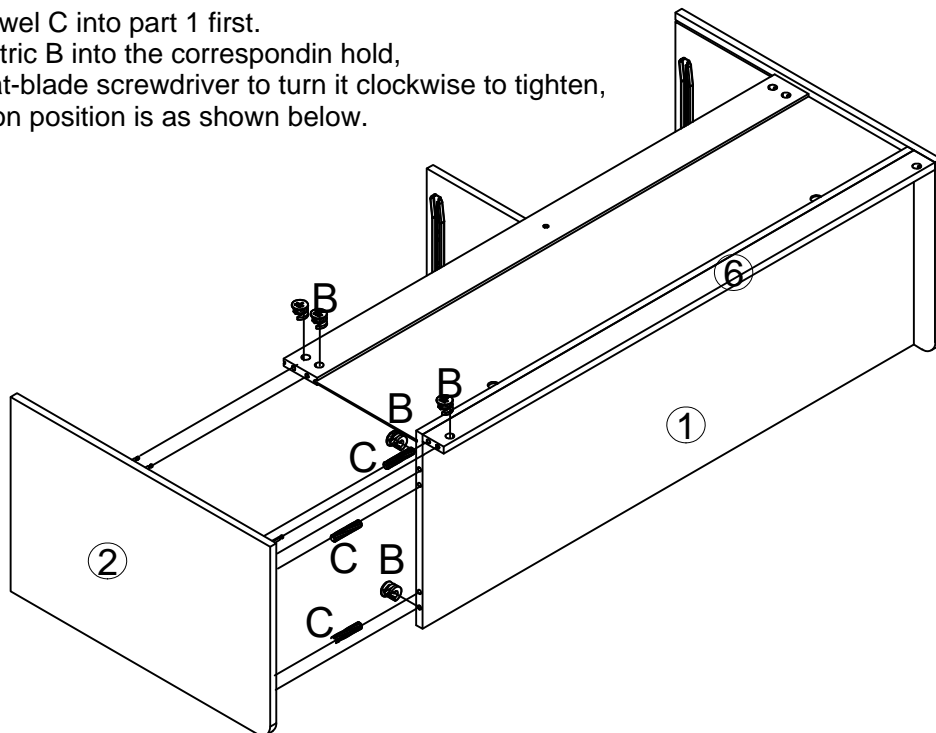

# STEP10

Insert part 9 along the slot, the position is as shown.

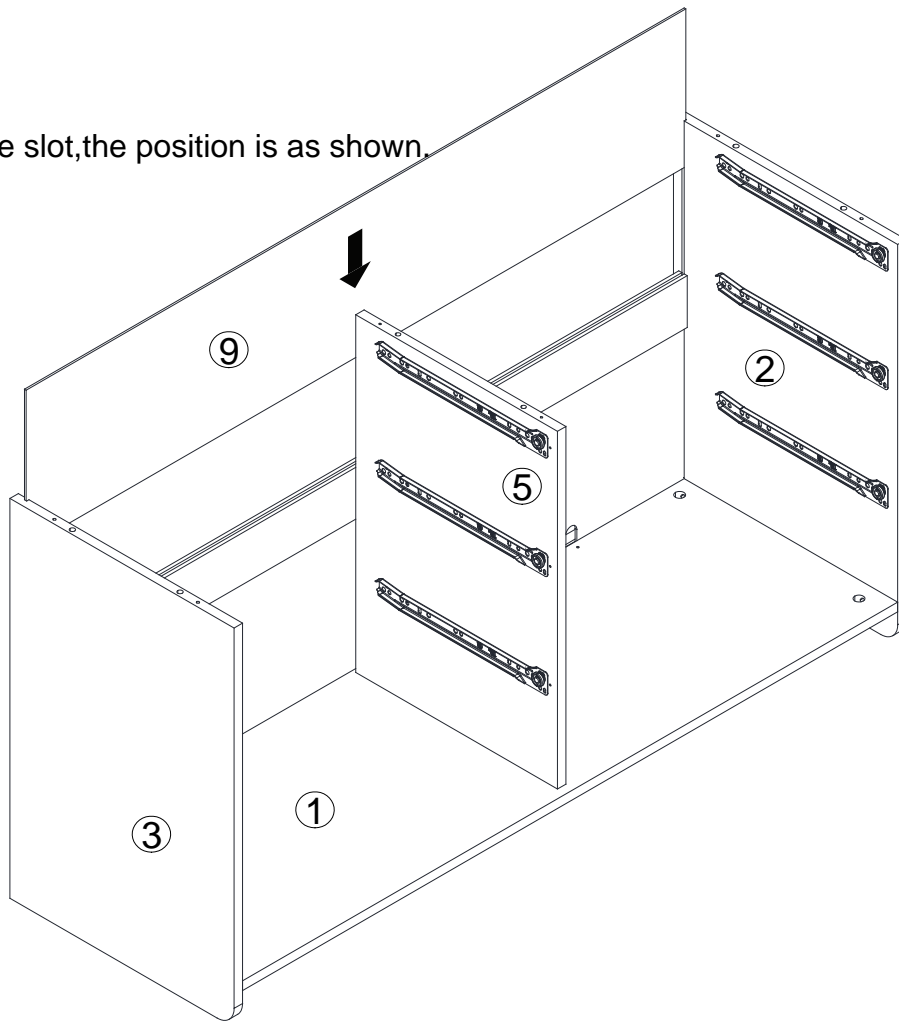

# STEP 11

Insert the dowel C into part 3;5;2 first,  
Assemble parts 4 and part 3;5;2 by screw E,

The installation position is as shown below.

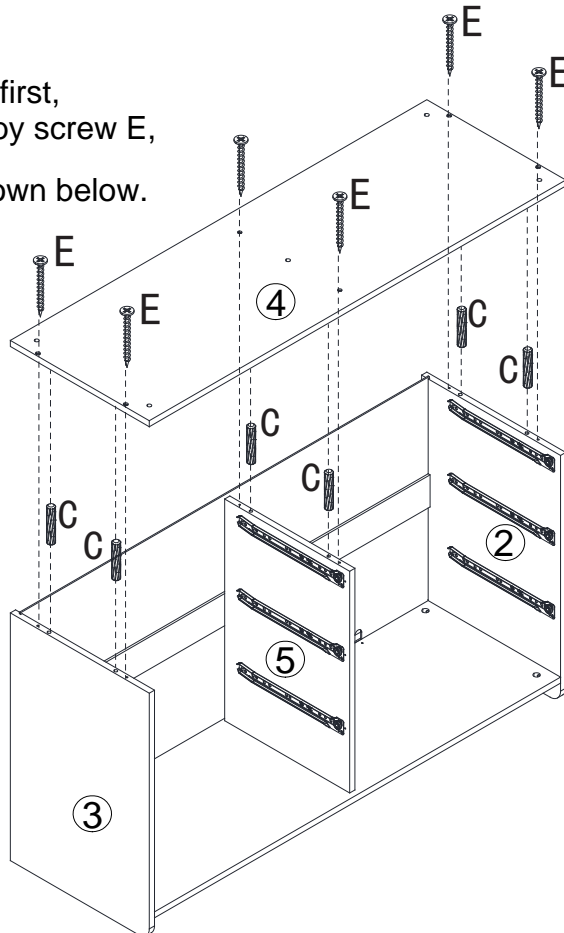

Ex6



Cx6



# STEP 12

Assemble part 10/11 to the bottom of the cabinet by hand.  
The installation position is as shown below.

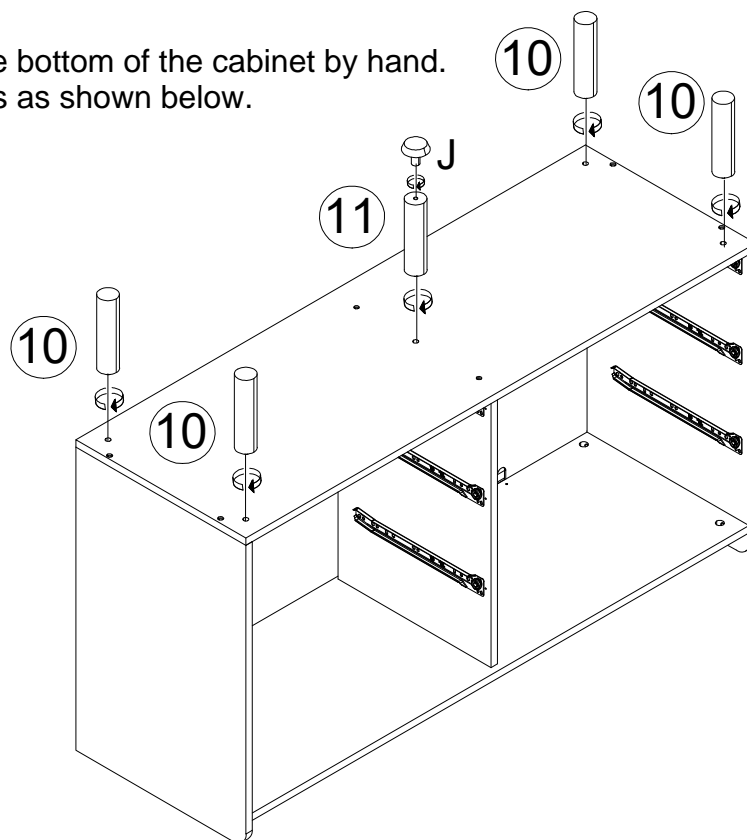

# STEP 13

Use the screws in component G&H to fasten the back plate buckle.  
The installation position is as shown in the figure below.

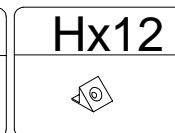
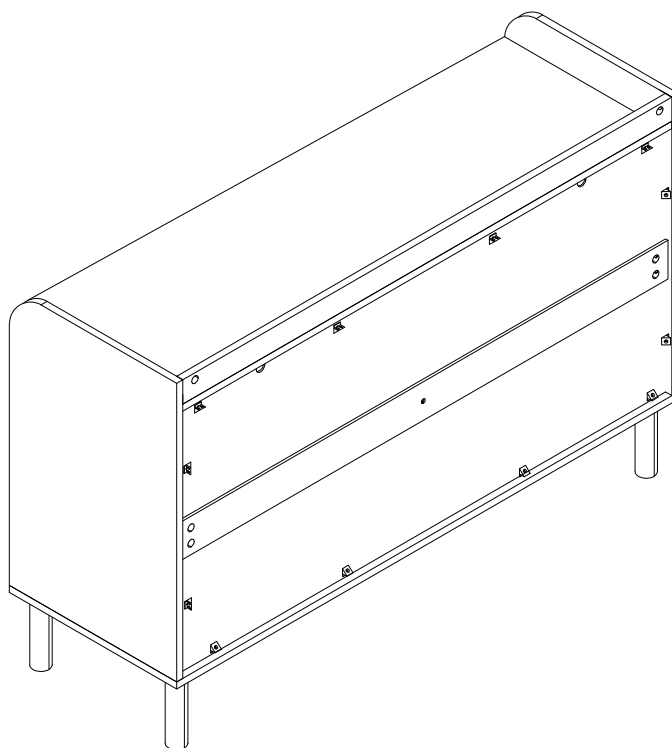

# STEP 14

Fasten the L-shaped iron piece K with screw L

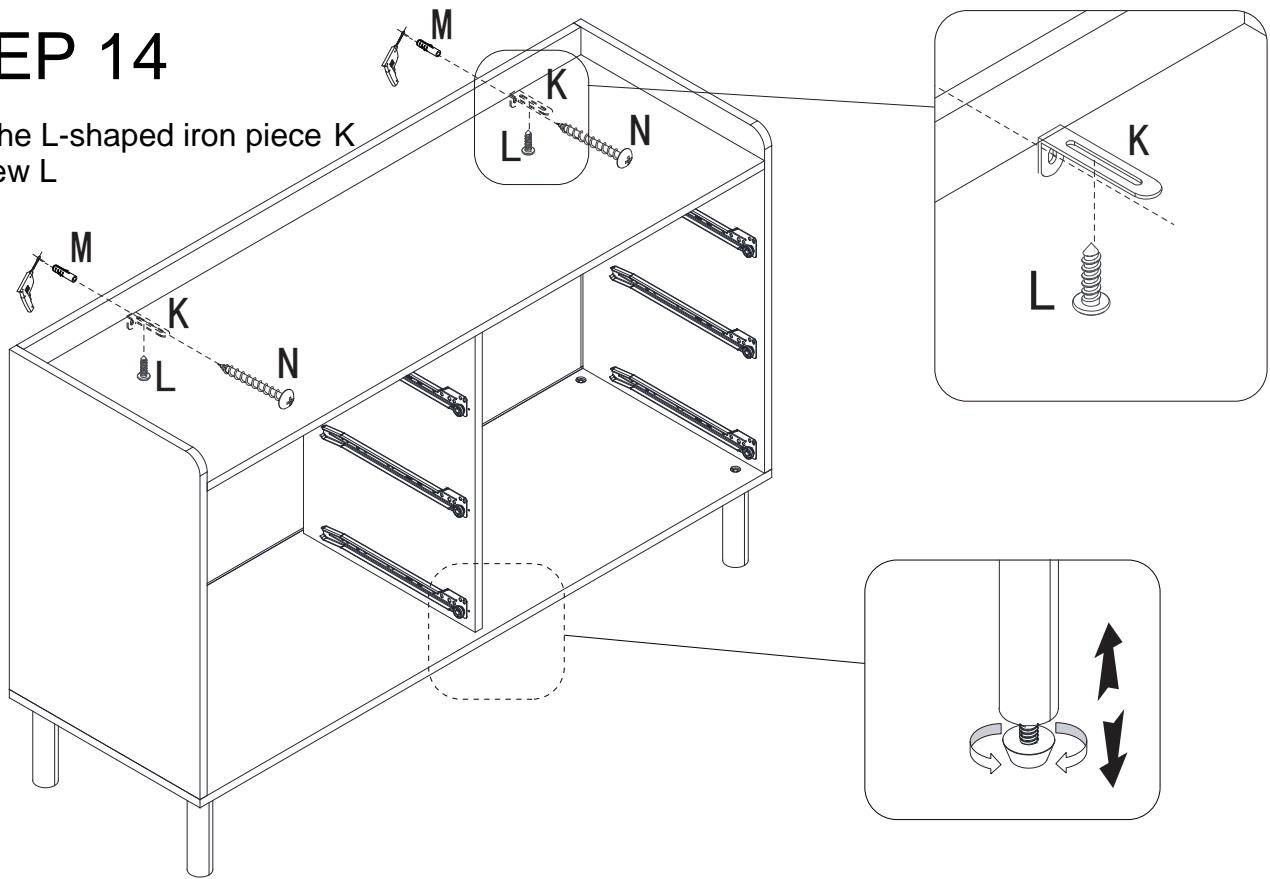

First drill holes on the wall where it is placed, and then use the long screw and expansion screw M to fix the cabinet with screw N.

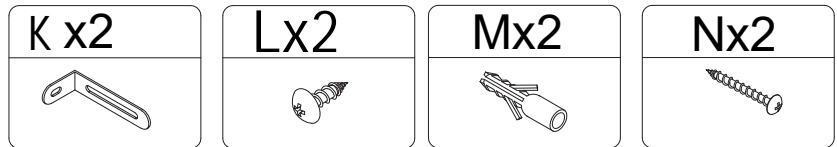

# STEP 15

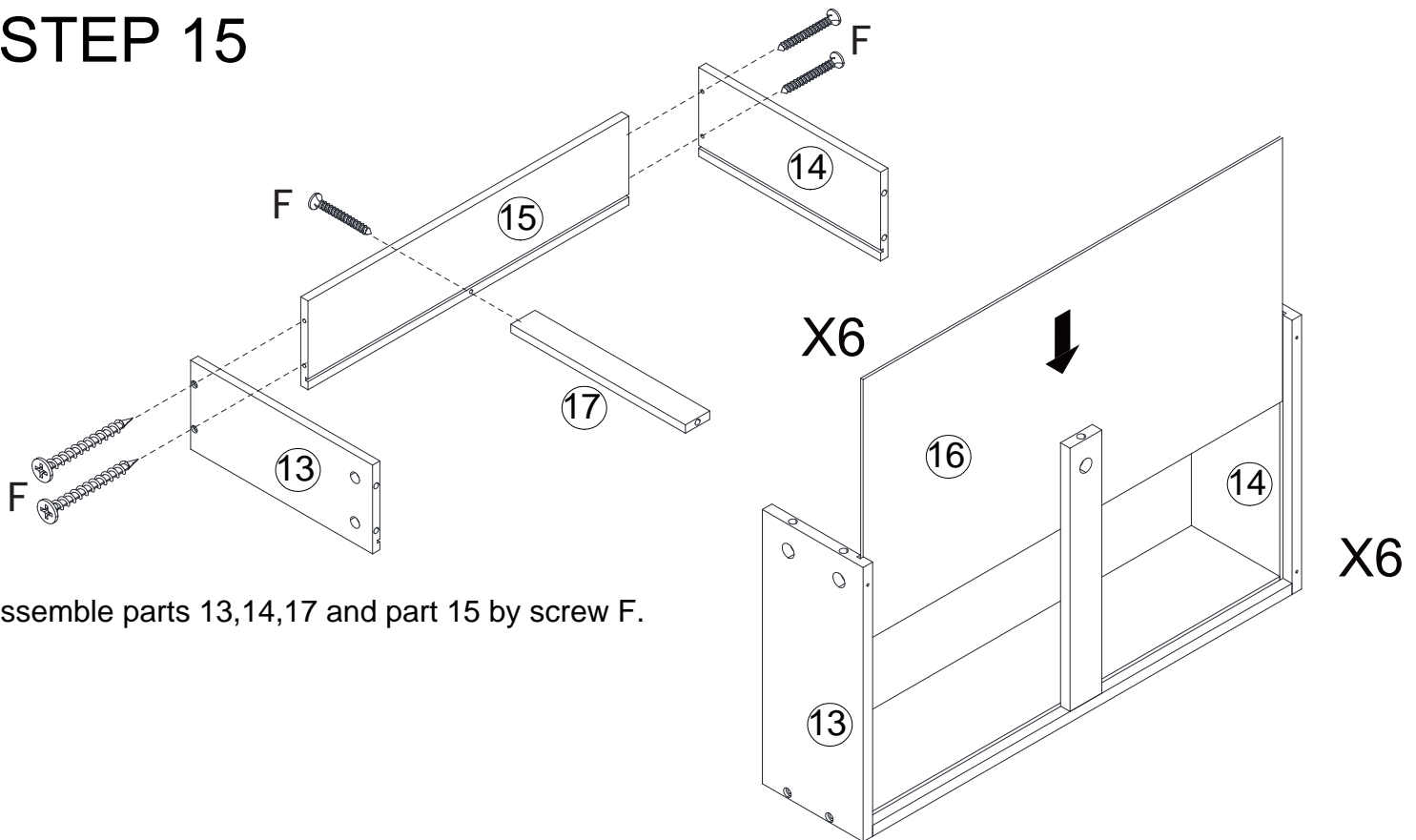

Assemble parts 13, 14, 17 and part 15 by screw F.

Insert the bottom plate 16 according to the slot

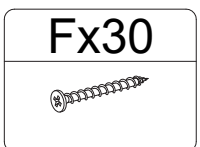

# STEP 16

Install the screw A on the drawer panels 12 first, and then use the screw O to lock the handle I on the drawer panels 12.

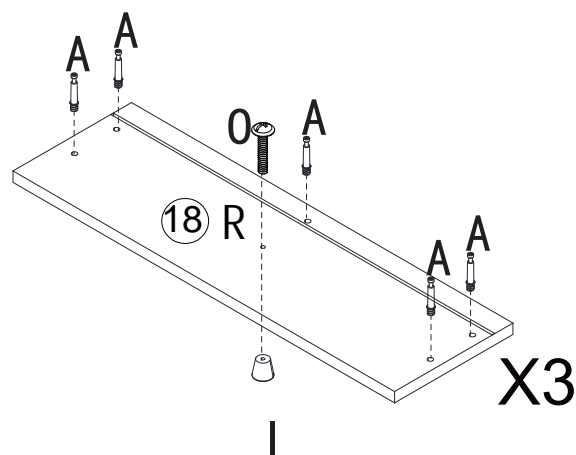
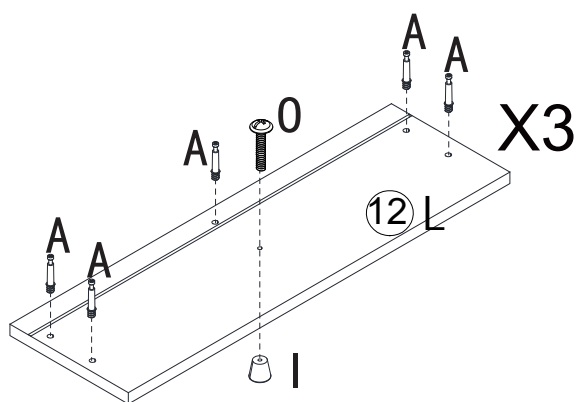

flat-blade screwdriver

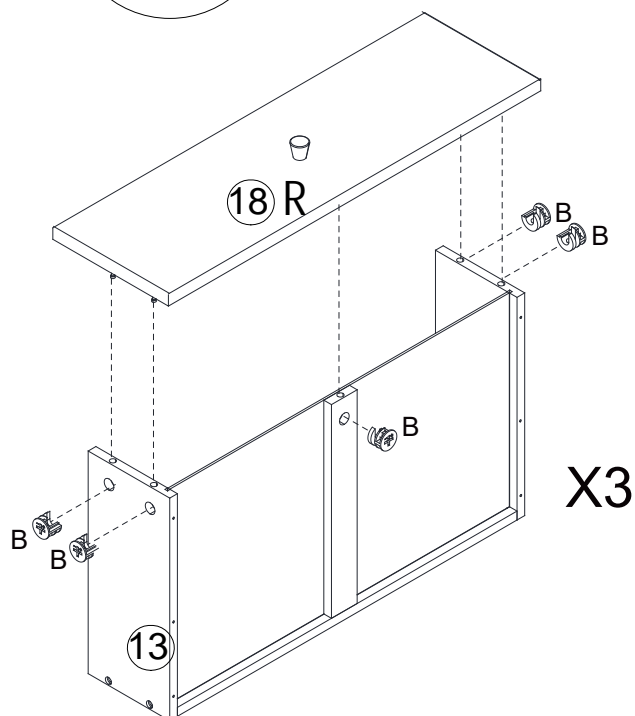
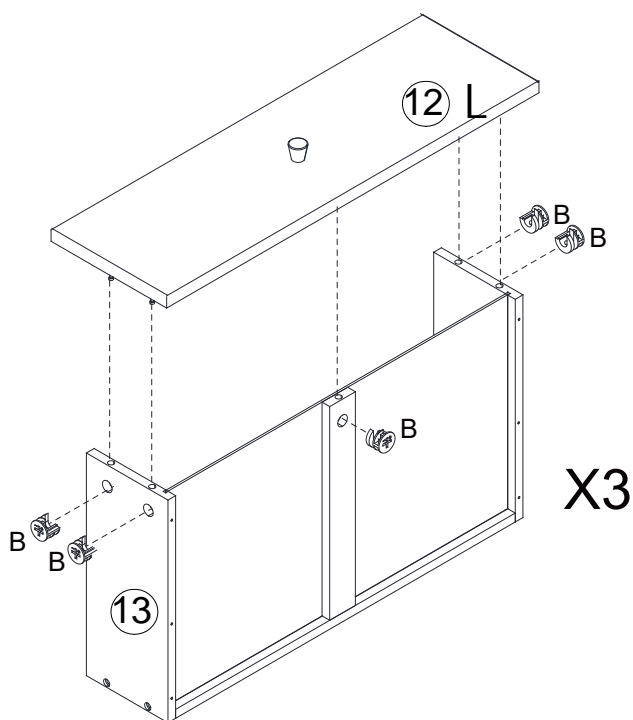
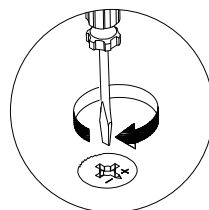

Put the eccentric B into the corresponding hole and use a flat-blade screwdriver to turn it clockwise to tighten, assemble drawer front.

Ax30	Bx30	Ox6	Ix6

# STEP 17

Use the screw D to install the guide rail DR/DL on the drawer side panel. the installation position is as shown in the figure below.

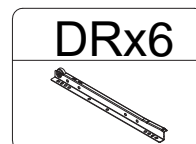
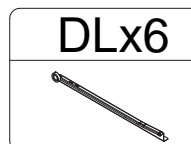
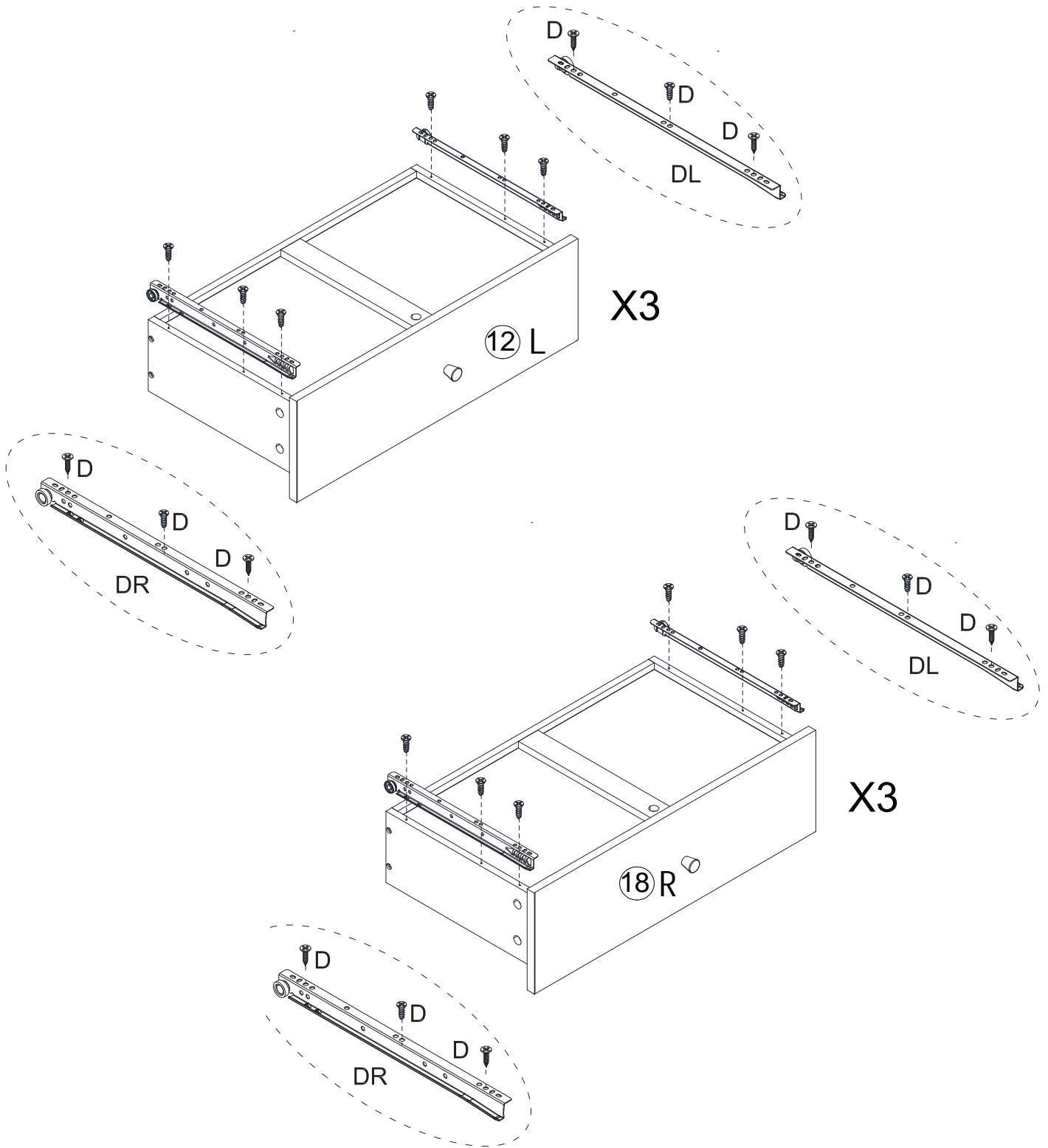

# STEP 18

