

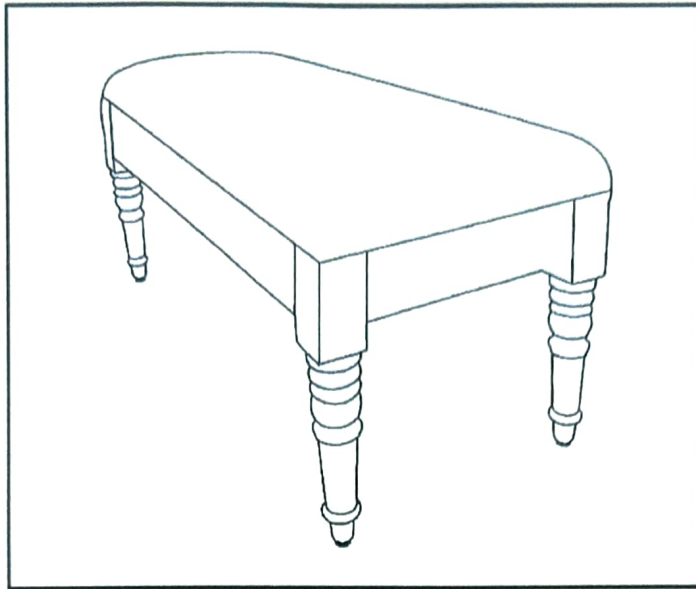

BENCH ASSEMBLY INSTRUCTION

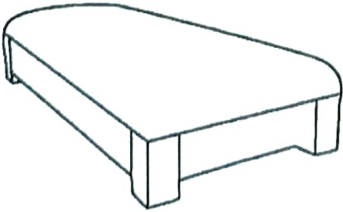

- Assembly time 20 minutes
- Unpack all hardware bags and components to ensure you have all parts
- Recommended for two Person assembly
- Assemble on a clean non-marring surface (packing foam)
- Save all packaging until finished

What is included

REFERENCE LABEL	IMAGE	DESCRIPTION	QTY
B 1		Seat	1
B 2		Leg	4

Step 1

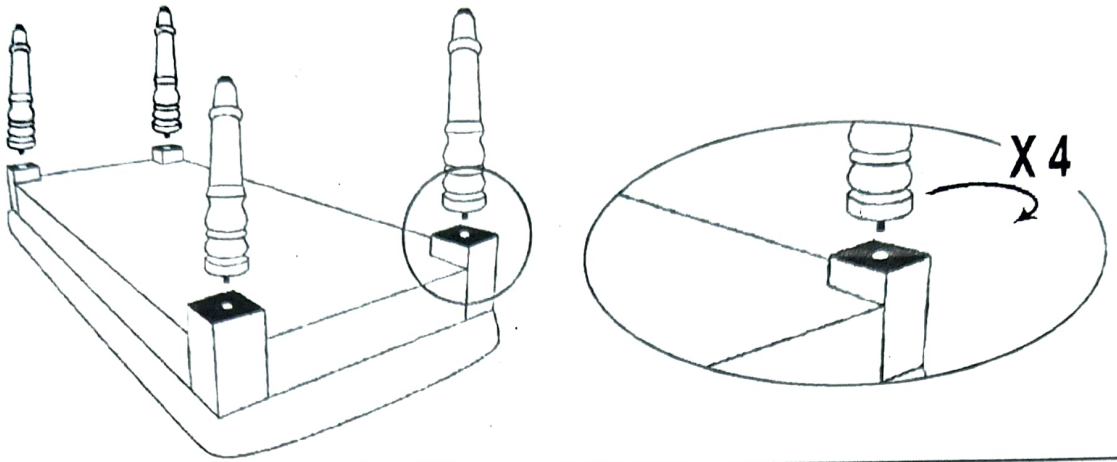

Place Seat (B 1) upside down on a padded non-marring surface. Take a Leg (B 2) align the Leg on pre installed, threaded insert underneath Seat (B 1). Rotate the leg (B 2) in clockwise direction until fully tightened & make sure it is not overtighten also.

Step 2

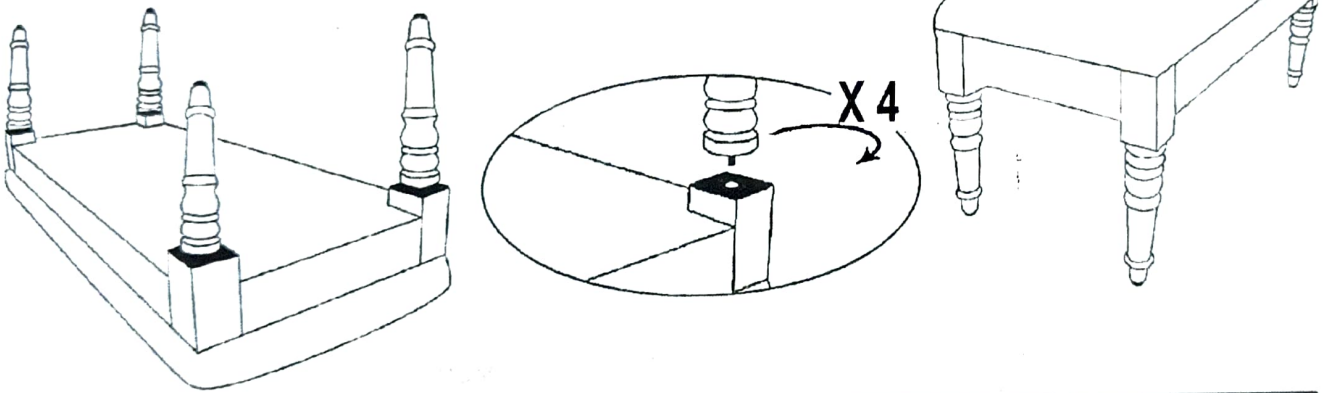

Repeat step 1 to assemble other legs. Gently turn the piece in upright position.

Step 3

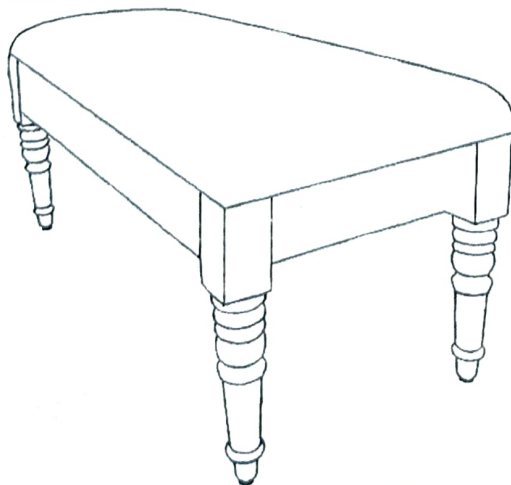

Gently turn the piece in upright position. Assembly is complete and product is ready to use.