

---

NOTE:

---

This brochure contains IMPORTANT safty info. Please read and keep for future reference.

# MAINTAINANCE

## AND WARNING

- Keep furniture away from heat.
- Do not clean furniture with harsh cleansers or polish. Do not use detergents, Solvents, abrasives, spray packs or leather cleaner. Use non-color mild soap with warm water clean spills(Mix 1:10 soap to water)
- Do not place furniture under direct sunlight, material will possibly fade over time.
- Do not use on site dry Cleaning machine.
- Children should not climb or jump on the furniture.
- Do not write on furniture without a padded barrier to protect the surface.
- Not for commercial use, For residential use only.



Weight Limitation

80LBS

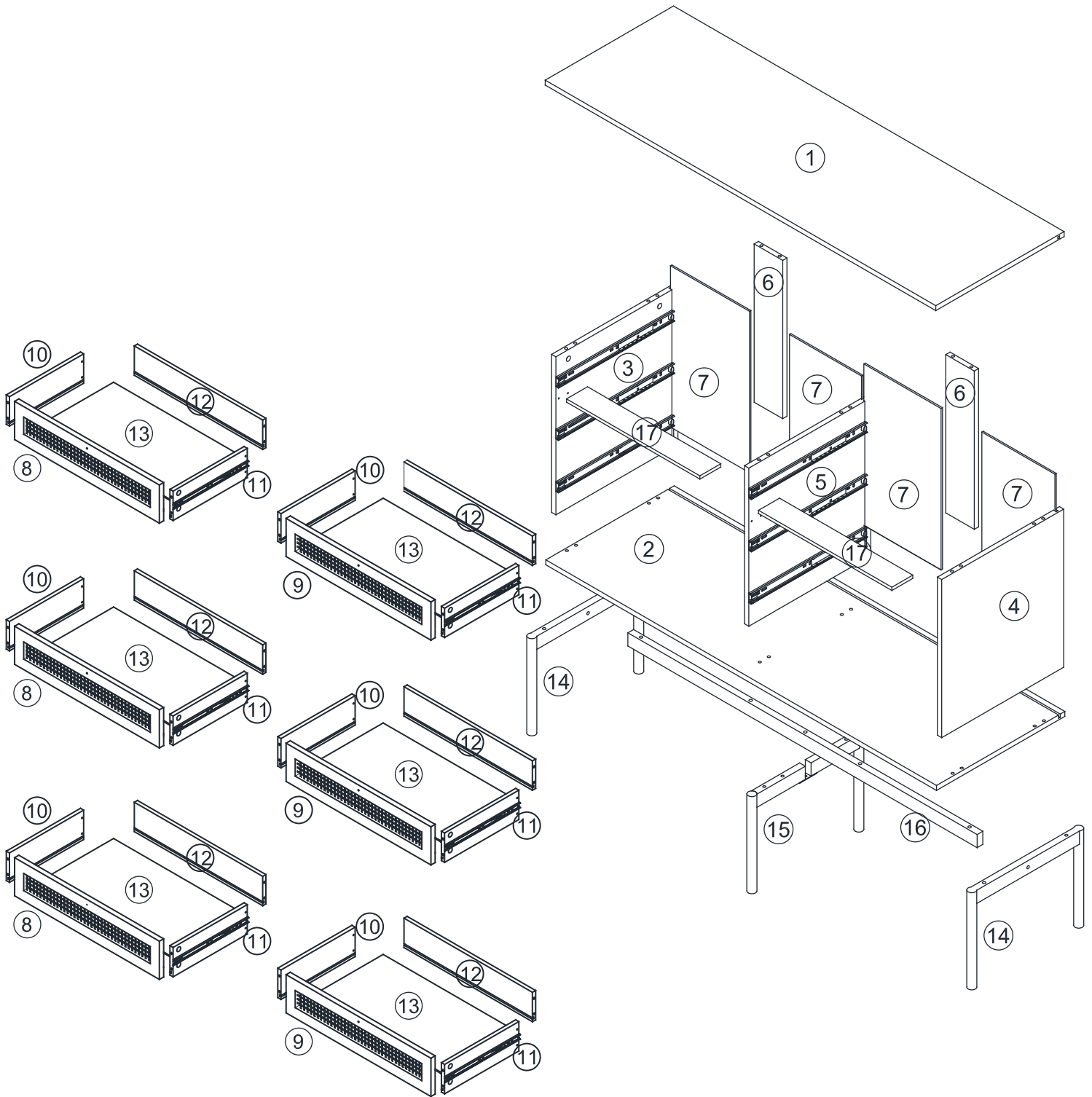

# OVERVIEW

# PARTS LIST

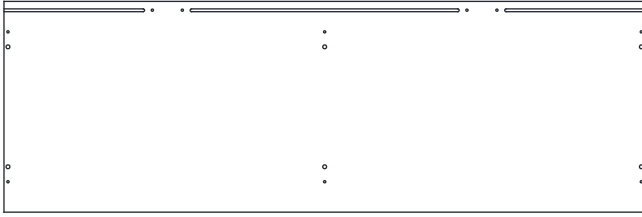

① x1

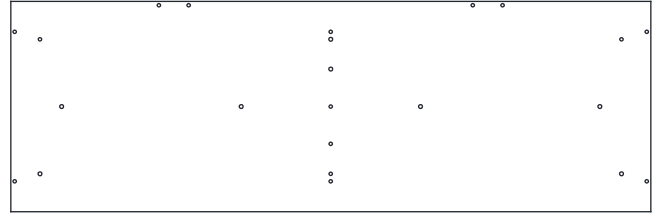

② x1

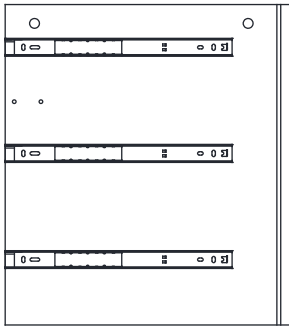

③ x1

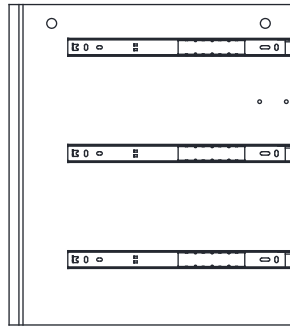

④ x1

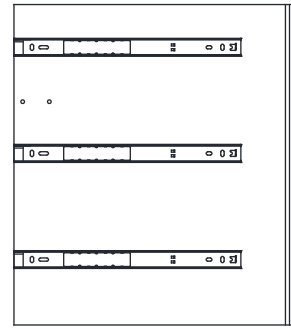

⑤ x1



⑥ x2

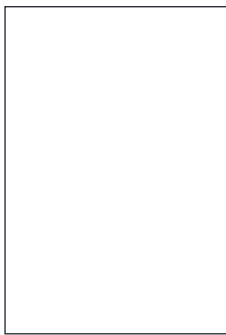

⑦ x4

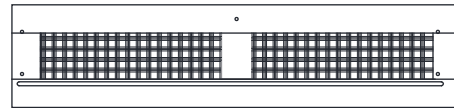

⑧ x3

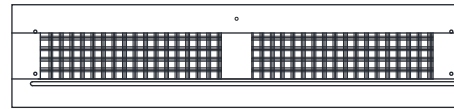

⑨ x3



⑩ x6



⑪ x6



⑫ x6



⑬ x6

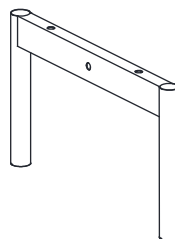

⑭ x2

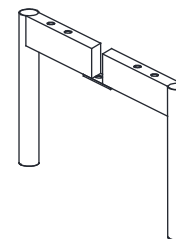

⑮ x1





















⑯ x1









⑰ x2

# HARDWARE LIST

A	x42	B	x42	C	x10	D	x12	E	x20	F	x6	G	x6	H	x16
															
M6*35mm		Ø15mm		M7*50mm		Ø8*30mm		Ø3.5*14mm				M4*30mm			
I	x6	J	x42	K	x1	L	x28	M	x4	N	x2	O	x4	P	x13
															
Ø13 mm				M4		Ø4*35mm								M6*50mm	
Q	x2	R	x1												
															
M6*45mm															

## SPARE



A	x4	C	x1	E	x2	G	x1	L	x2	P	x1	Q	x1
													
M6*35mm		M7*50mm		Ø3.5*14mm		M4*30mm		Ø4*35mm		M6*50mm		M6*45mm	

Be sure to check all packing material carefully for small parts, which may have come loose inside the carton during shipment.

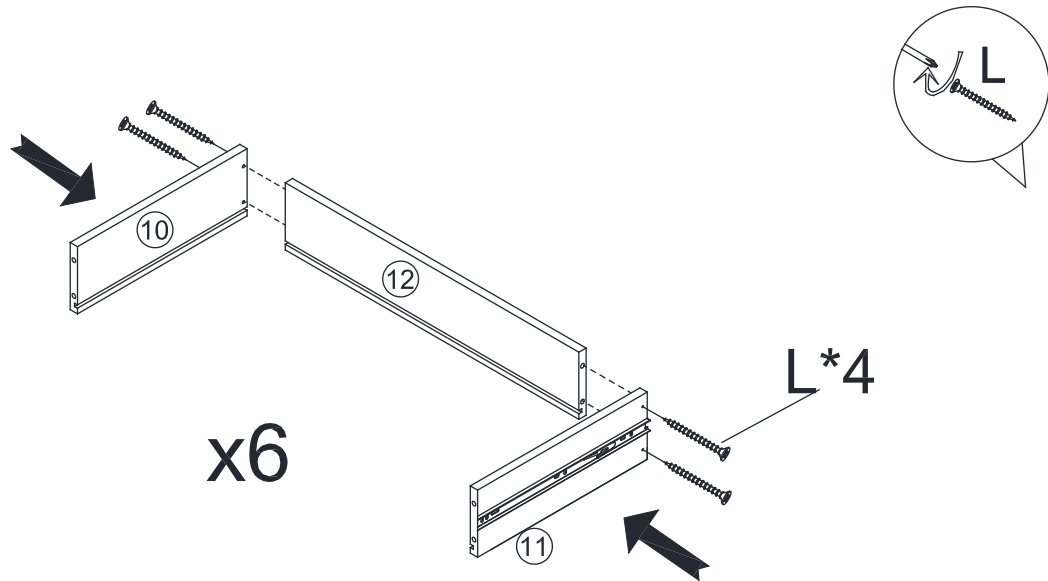
## STEP 1



Connect the part 10,11 with part 12.  
Align the hole in part 10 and 11 to the hole in part 12 as the picture show. screw in the screw L and tighten by screwdriver R.  
There are total 6 sets need to finish.

R	x1	L	x24
			
		Ø4*35mm	

## STEP 2

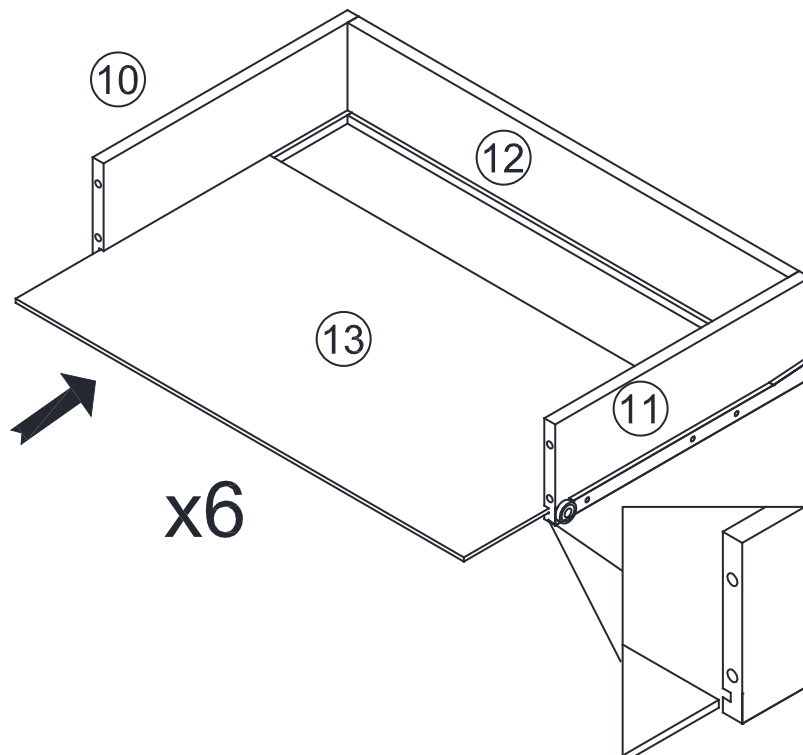

Connecting the part 13 to the finished part in step 1.  
Align the groove in part 10,11 and 12. insert and slide down to the end.  
Be sure part 13 go into the groove of part 12!

## STEP 3

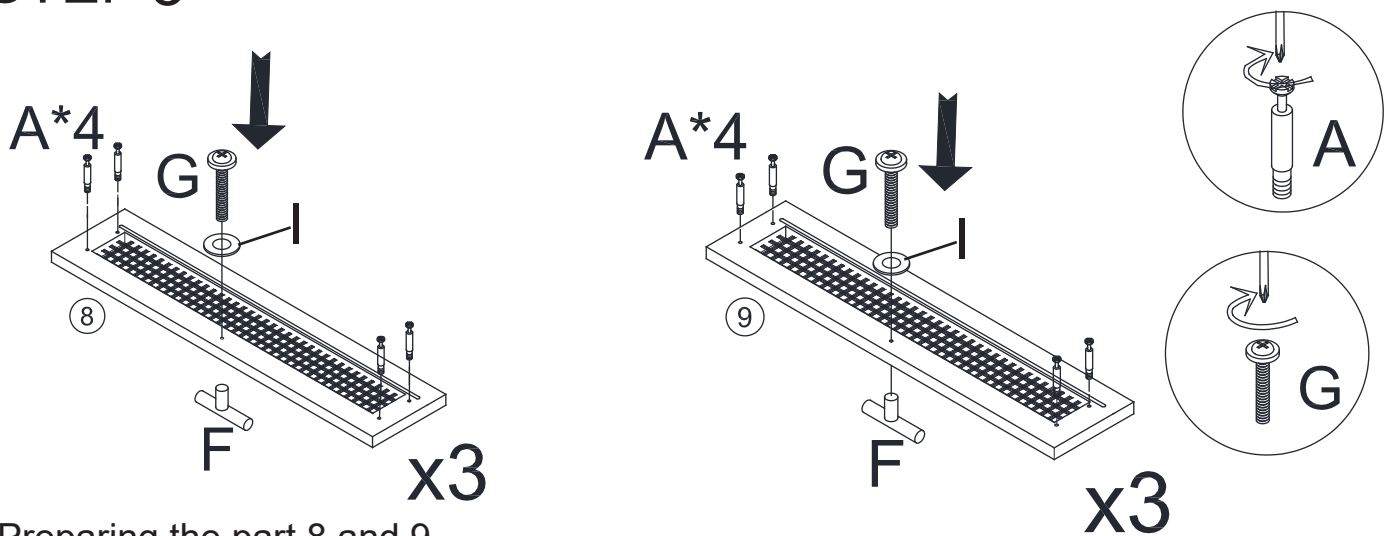



Preparing the part 8 and 9

- 1) Align the hole in part 8 as the picture show, screw in the cam bolt A and tighten by screwdriver R.
- 2) Align the hole in part 8 to the hole in part F, screw in the screw G with part I and tighten by screwdriver R.
- 3) Repeat the same way to finish part 9 with part F

R	x1
	

A	x24
	
M6*35mm	

F	x6
	

G	x6
	
M4*30mm	

I	x6
	
Ø13 mm	

## STEP 4

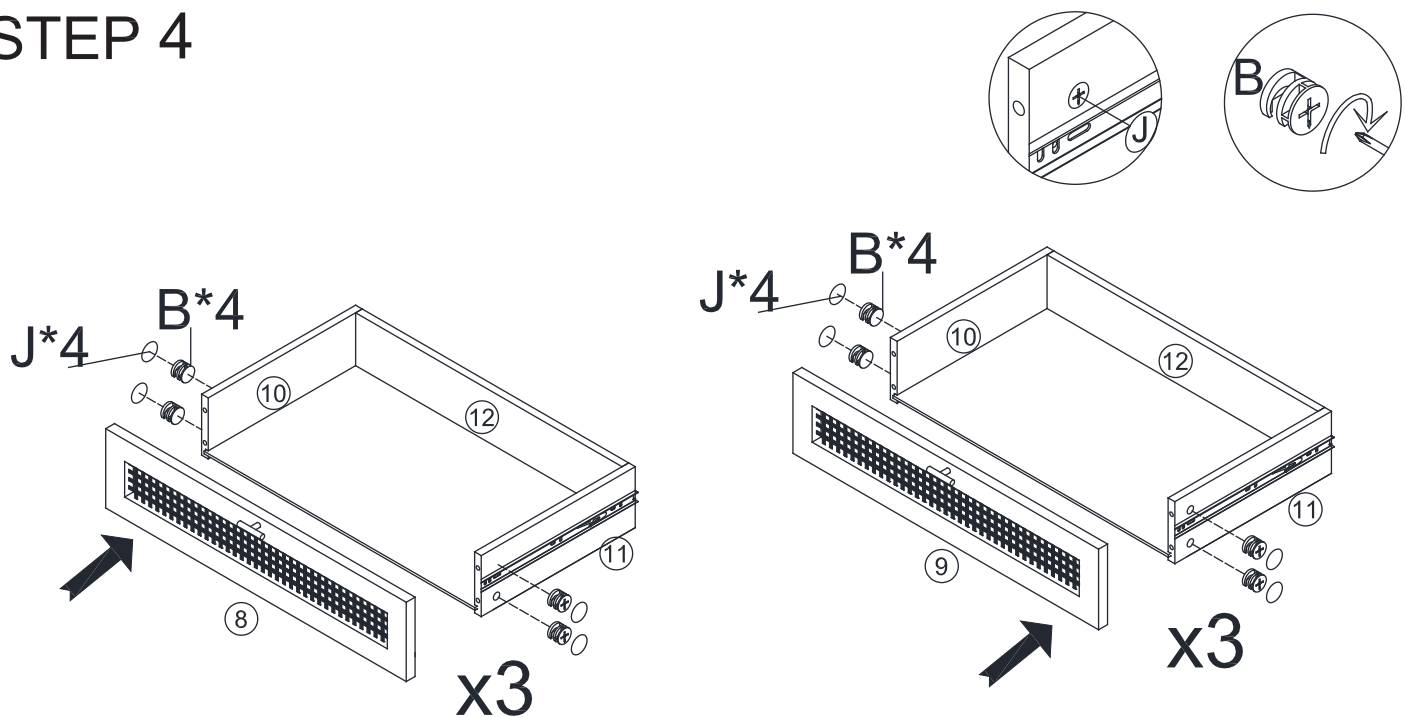

Connecting part 8,9 to the finished part in step 2.

- 1) Align the hole in part 8 and 9, insert the cam bolt A into the hole in part 10 and 11 As the picture show.then
- 2) Put the nut B into the hole from side, then tighten the nut by screwdriver R.
- 3) Last, peel the part J and cover the nut B for good looking.

R	x1
	

B	x24
	
Ø15mm	

J	x24
	
Ø20	

# ASSEMBLY INSTRUCTIONS

## STEP 5

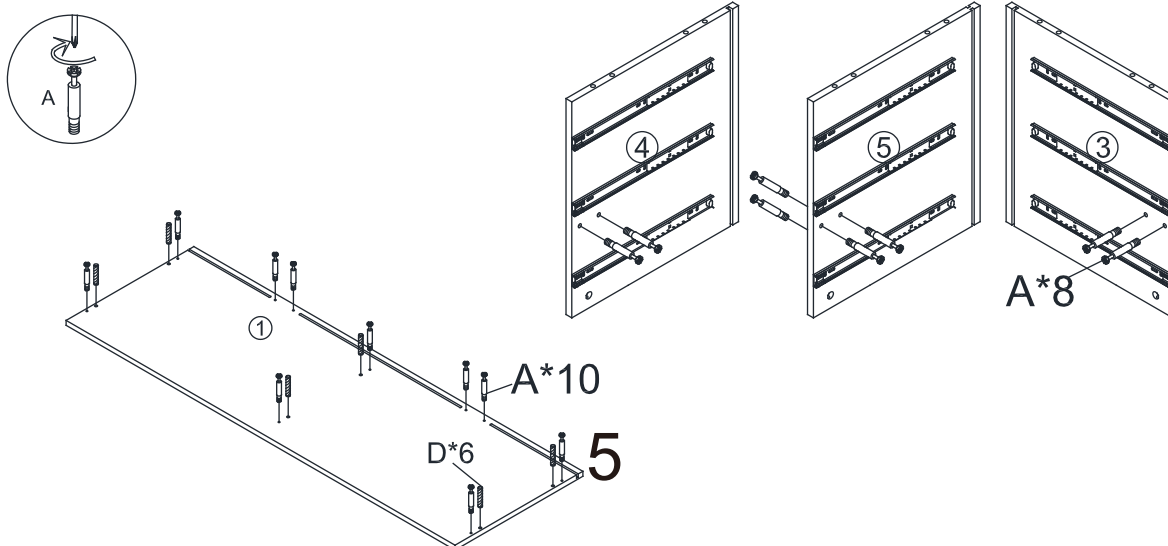

Preparing the part 1 and part 3, 4, 5

- 1) Align the hole in part 1, insert the part D(wooden dowel) into the hole by hand;
- 2) Align the hole in part 1, 3, 4 and 5, screw in the cam bolt A into the hole and tighten by screwdriver R.

R	x1	A	x18	D	x6
		M6*35mm		Ø8*30mm	

## STEP 6

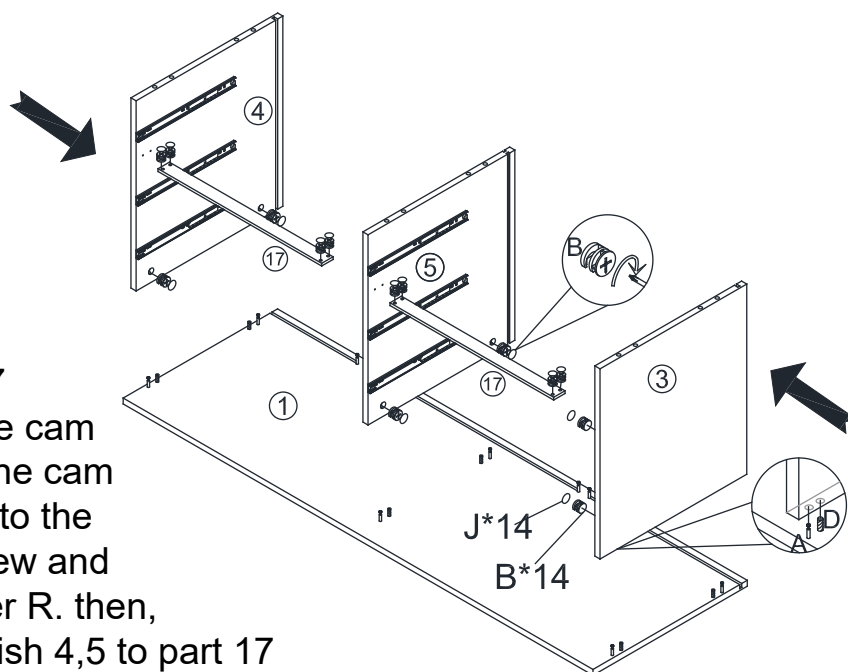

Assemble the part 3,4, 5 and 17

- 1) Align the hole in part 17 to the cam bolt A in part 3 and 5 insert the cam bolt A, then put the NUT B into the hole as the picture show, screw and tighten the nut by screwdriver R. then, REPEAT the same way to finish 4,5 to part 17
- 2) Align the hole in part 3 and 4, 5 to the part A and D in the part 1, insert the part A and D into the hole in part 3,4, 5,put nut B into the hole and tighten by screwdriver R.
- 3)Use part J to cover the nut B for good looking.

R	x1	J	x6	B	x6
				Ø15mm	

## STEP 7

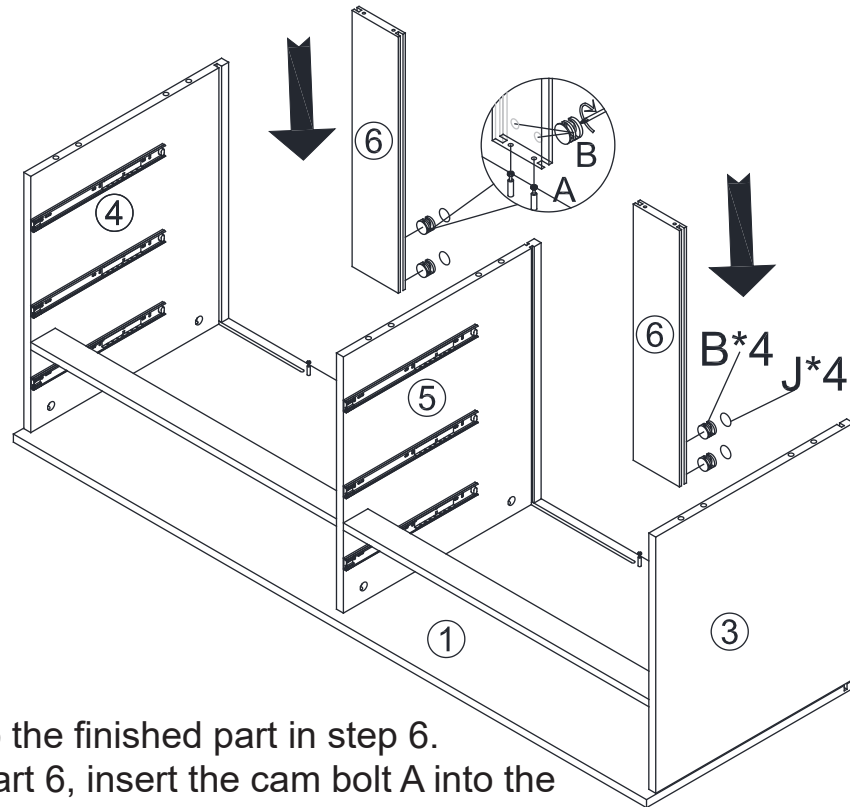

Connect the part 6 to the finished part in step 6.

- 1) Align the hole in part 6, insert the cam bolt A into the hole as the picture show.
- 2) Put the nut B into the hole in part 6, tighten by screwdriver R.
- 3) Use part J to cover the nut B for good looking.

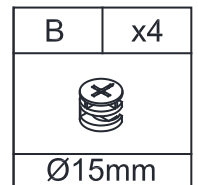
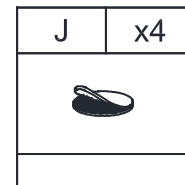
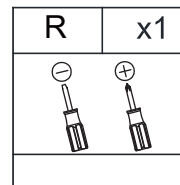

## STEP 8

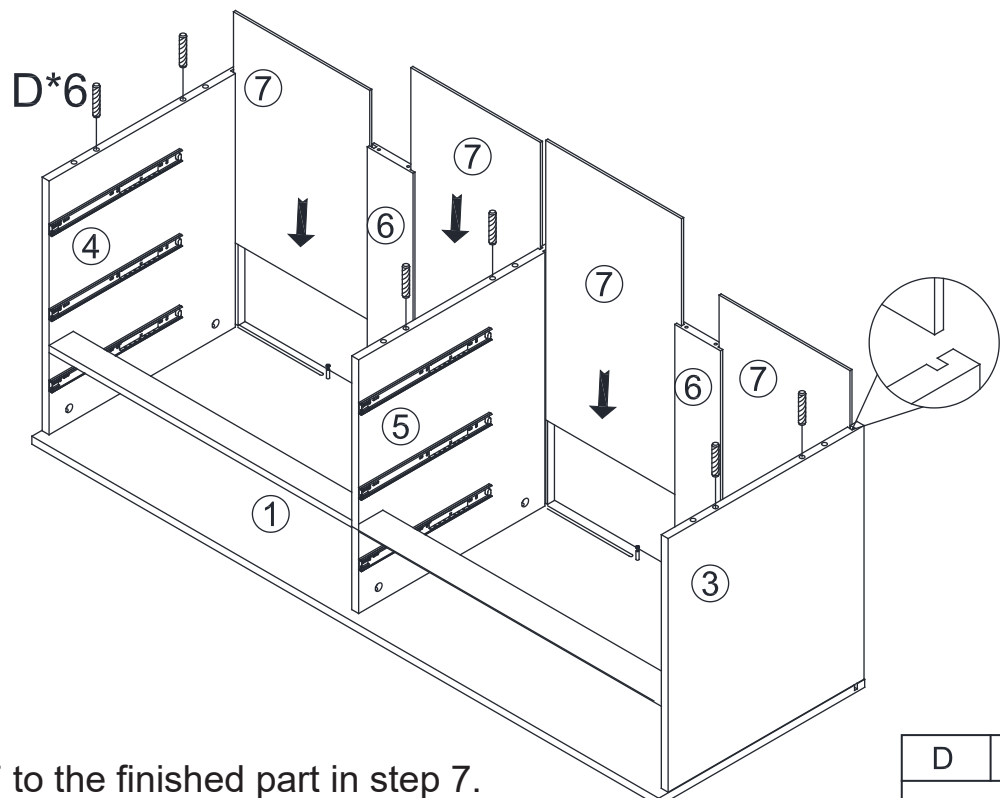

Connect the part 7 to the finished part in step 7.

- 1) Align the groove in part 1, 3,4,5, insert and slide the part 7 into the groove as the picture show.
- 2) Align the hole in part 3 and 4,5, insert the part D into the hole by hand.

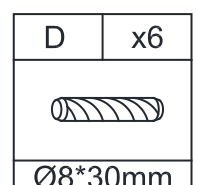

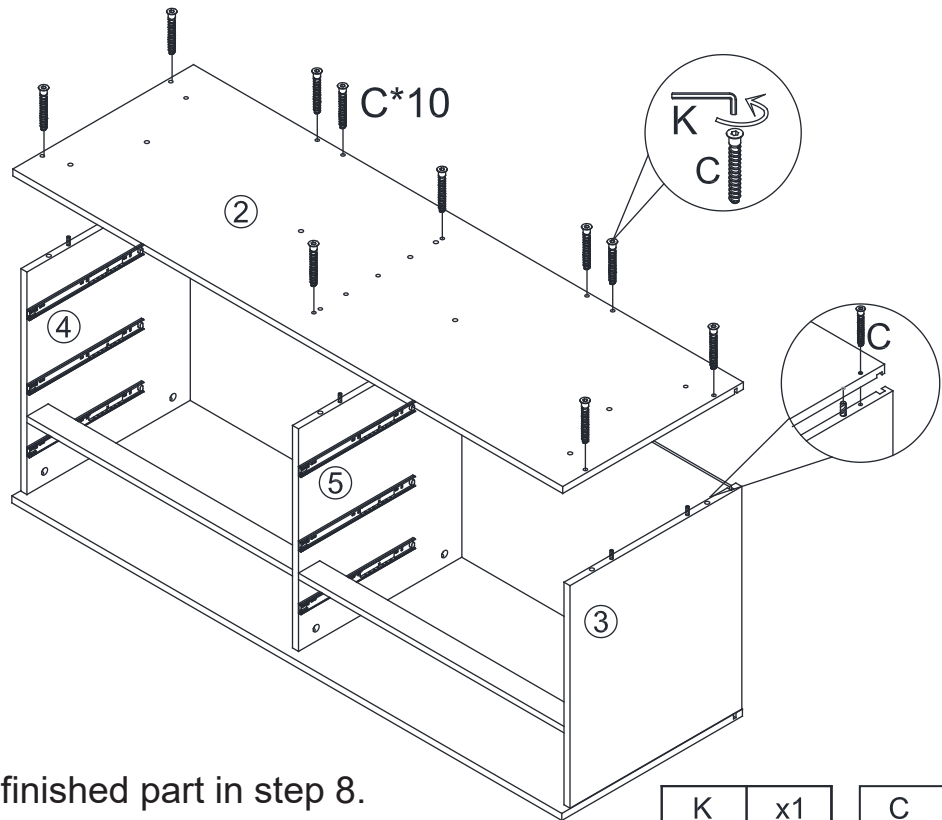

## STEP 9



Connect part 2 to the finished part in step 8.

- 1) Align the hole in the part 2, insert the part D in part 3,4,5 into part 2 , then,
- 2) Screw in the screw C and tighten by ALLENKEY K.

K	x1	C	x10
			
M4		M7*50mm	

## STEP 10

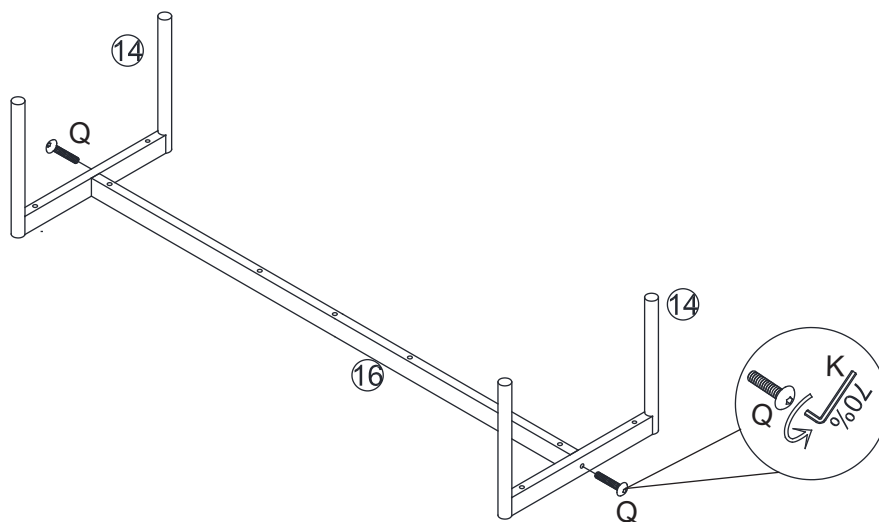

Attach the part 16 to the part14

Align the hole in part 16 to the hole in part 14, screw in the screw Q and tighten by Allenkey K.

Do not fully tighten at this step!

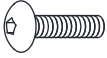
K	x1	Q	x2
			
M4		M6* 45mm	

# STEP 11

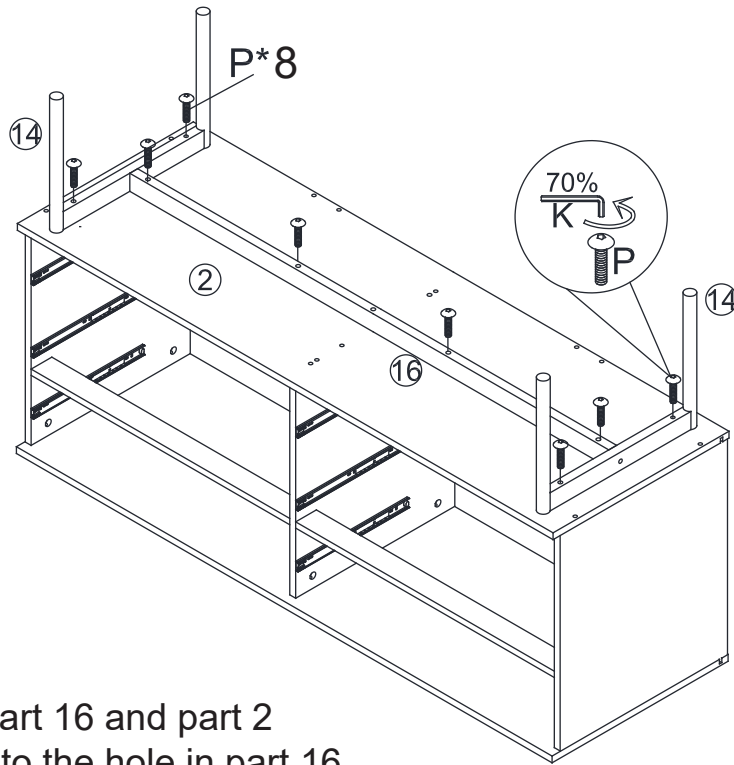

Connect part 14 to the part 16 and part 2  
 Align the hole in part 14 to the hole in part 16,  
 screw in the screw Q and tighten by Allenkey K;  
 Align the hole in part 14 to the hole in part 2, screw  
 in the screw P and tighten by Allenkey K  
 Do not fully tighten in this step!

K	x1
	
M4	

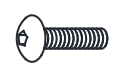
P	x8
	
M6*50mm	

# STEP 12

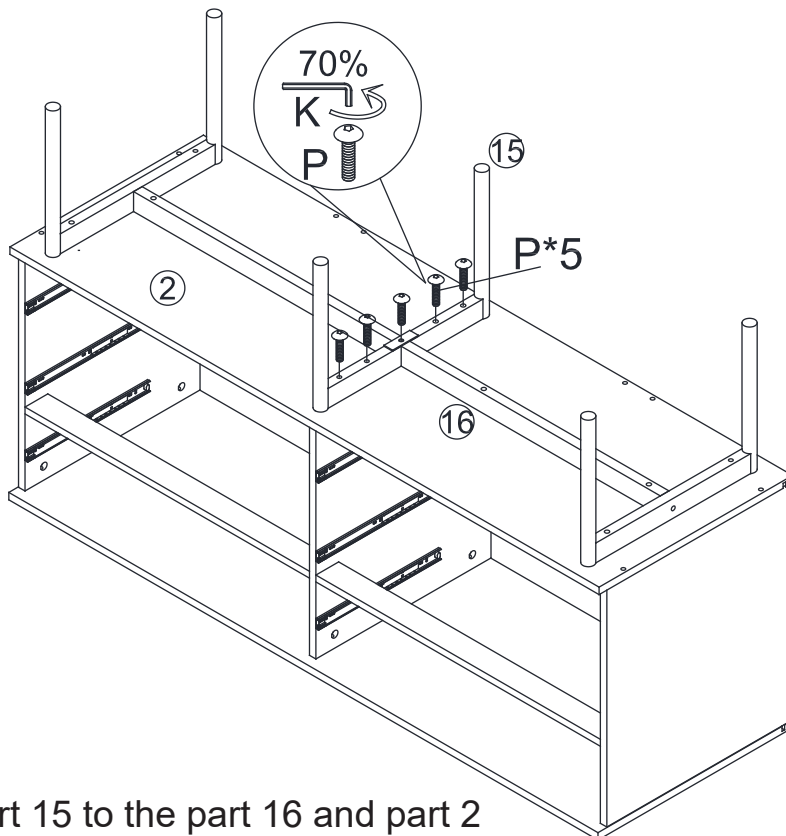

Connect the part 15 to the part 16 and part 2  
 Align the hole in the part 15 to the hole in part 16 and part 2,  
 screw in the screw P and tighten by Allenkey K.  
 After all screw in the position, start fully tighten part P  
 and Q in sequence.

K	x1
	
M4	

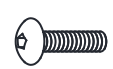
P	x5
	
M6*50mm	

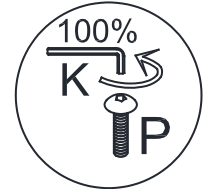

# STEP 13

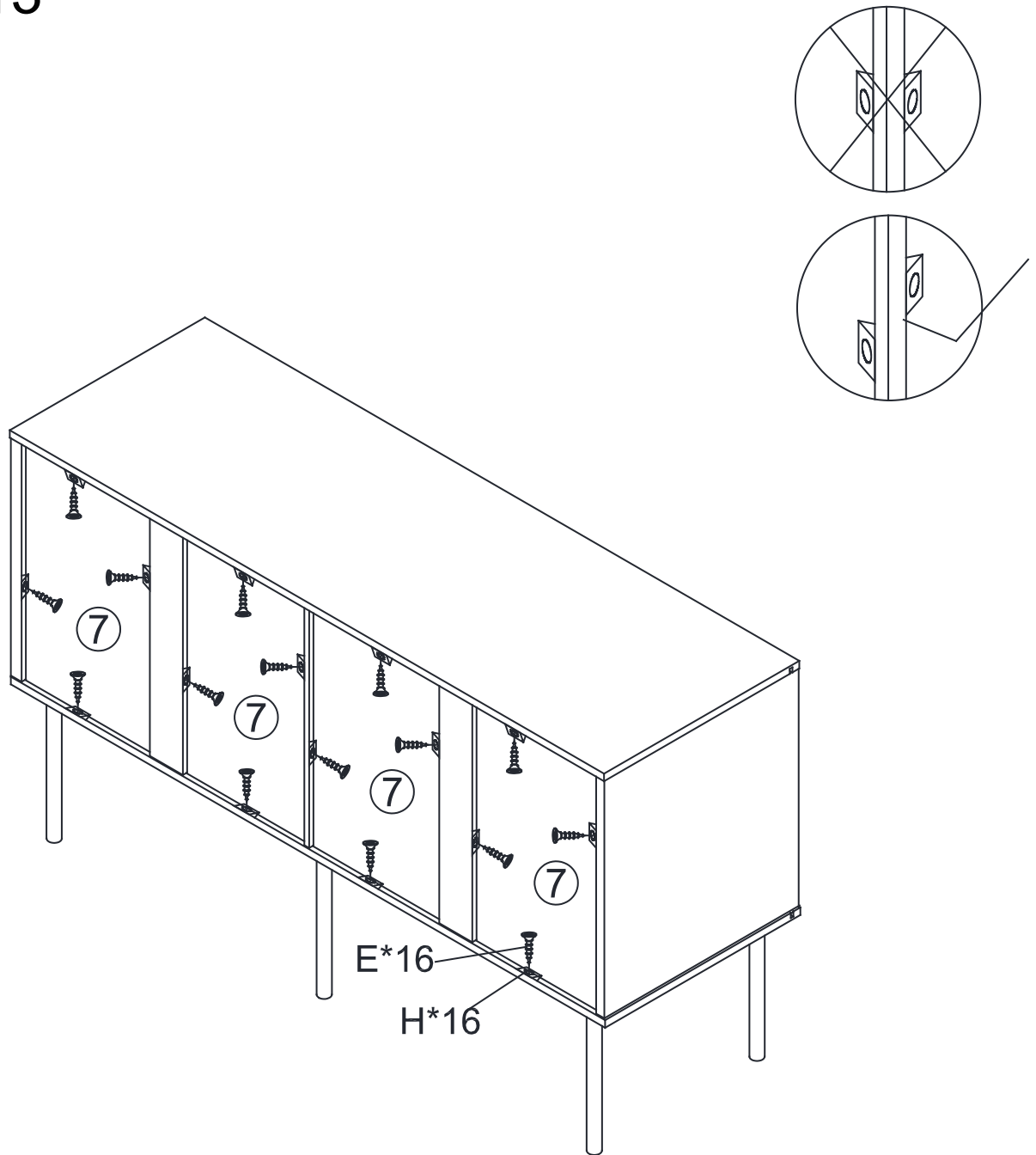

Assemble part H to finished part in step 12.

- 1) Turn the cabinet upwards as the picture show;
- 2) Put the part H in the position as the picture show, then screw in the screw E and fully tighten by screwdriver R.

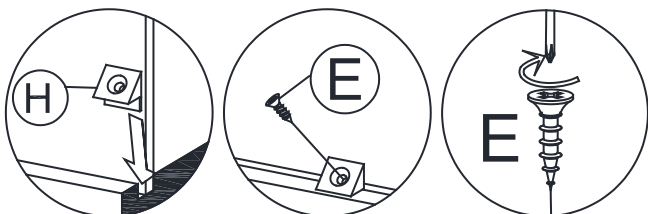

R	x1

E	x16
Ø3.5*14mm	

H	x16

# STEP 14

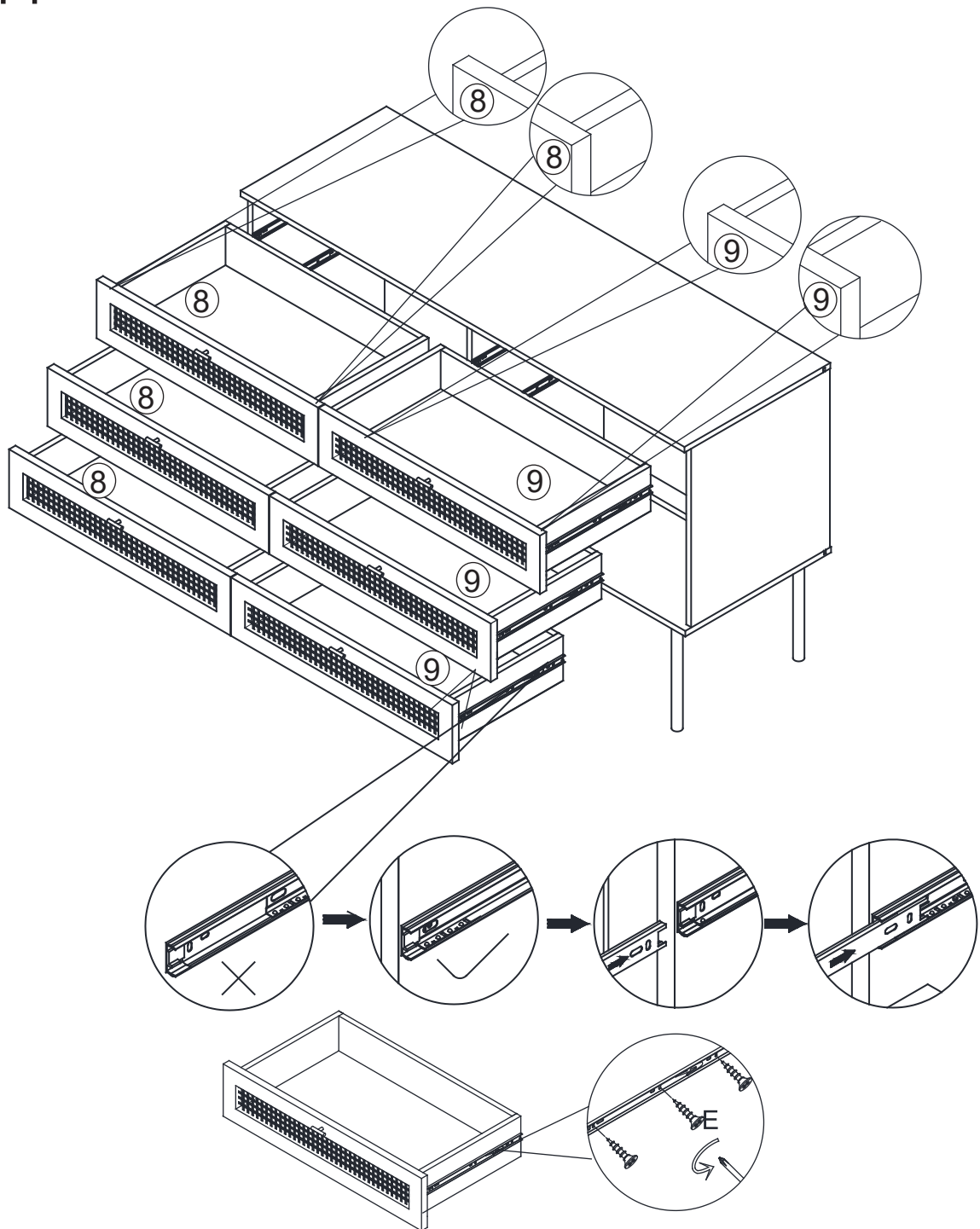

## Assemble drawer to the cabinet

- 1) Find the moving part in male metal slider in drawer sides(pre-assmbed ), be sure the moving part is in the back of metal slider as the picture show;
- 2) Find the moving part in female metal slider in the cabinet side(pre-assembled), be sure the moving part is in the front of metal slider as the picture show.
- 3) Align the male metal slider to the moving part in female metal slider, then push forward while two male sliders are in the moving part in female at the same time.
- 4) You can adjust the drawer to fit the cabinet once you need to do this. just loose the screw E , you can move the male metal slider to the position you expect, then fully tighten screw by screwdriver R.

# STEP 15

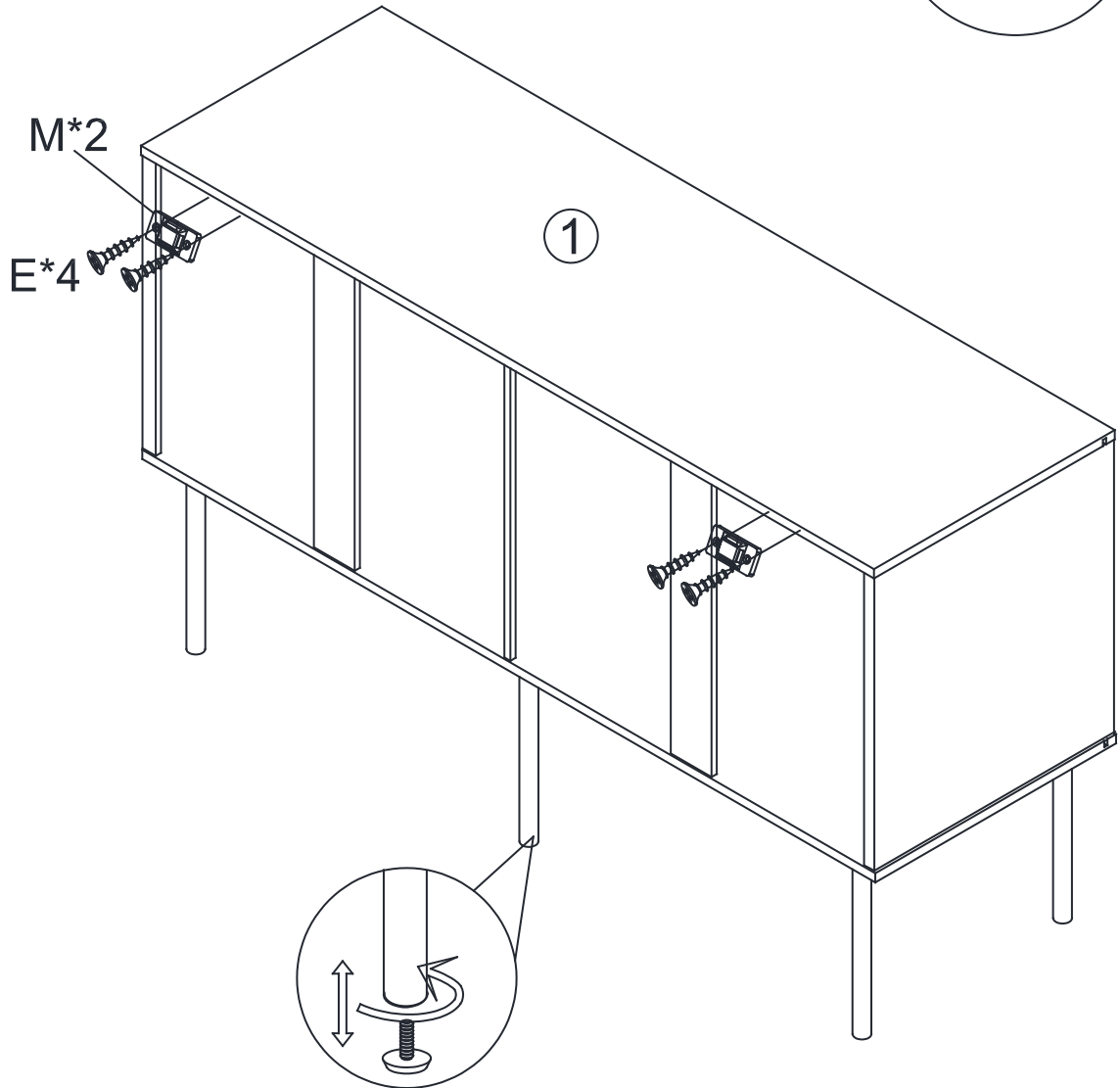
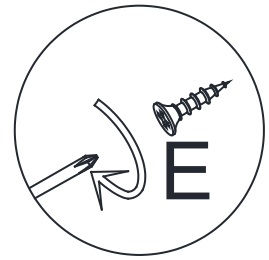

Assemble part M

Align the hole in part M to the part 1 as the picture show, screw in the screw E and tighten by screwdriver R.

You can use the nail to adjust cabinet level in case wabbling

Use the adjustable nail to keep the cabinet level in case the cabinet is wabbling.

Now your cabinet is ready to use.

R	x1	E	x4	M	x2
		Ø3.5*14mm			

# STEP 16

Install the anti-collapse device.

1. Mark the position on the wall, this should be same as the position of M where are on the back of panel 1; Drilled and insert the expandable screw O by hammer;
2. Assemble the part M on the wall. Align the hole in the part M to the expandable screw O, Screw in screw L and tighten with screwdriver R.
3. let the plastic belt N go through the both M and pull to tighten.

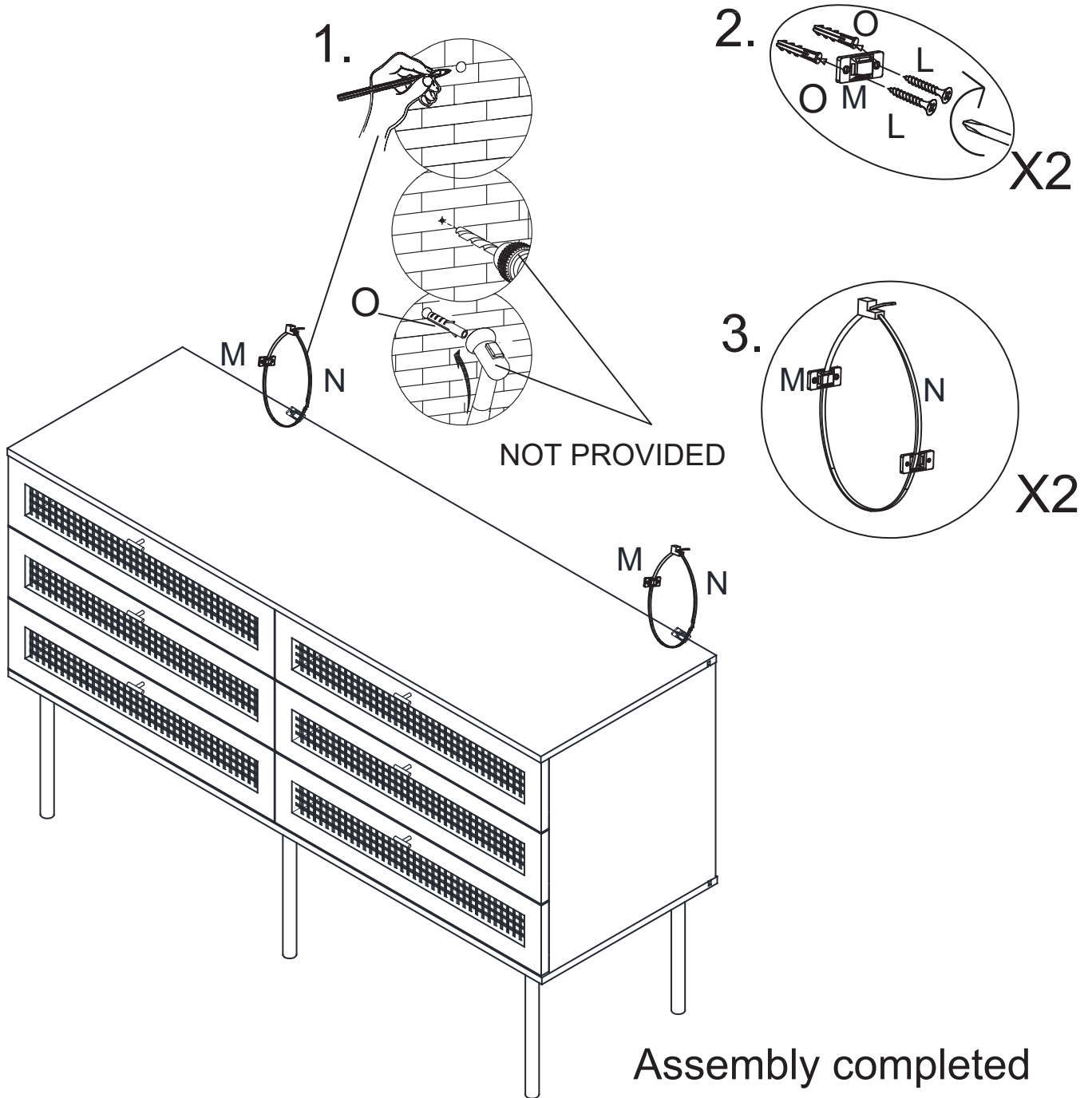

Assembly completed

R	x1	L	x4	M	x2	N	x2	O	x4
		Ø4*35mm							

# **WARRANTY**

We strive to offer high-quality products, and we also try our best to satisfy each and every customer that orders from us with product or service as needed. We provide 30 days warranty starting from the time you receive the item. Each customer must provide a record of their order such as the order number, or item receipt for any items that are out of the warranty period you may also still receive replacement parts by purchasing them with our company if they are available.