

ASSEMBLY INSTRUCTIONS

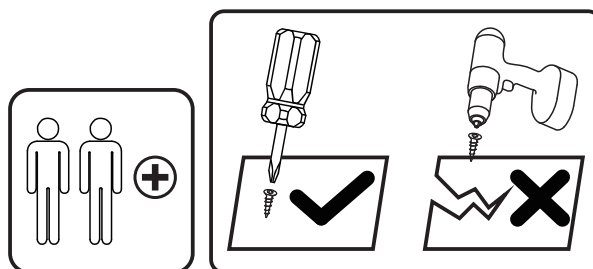
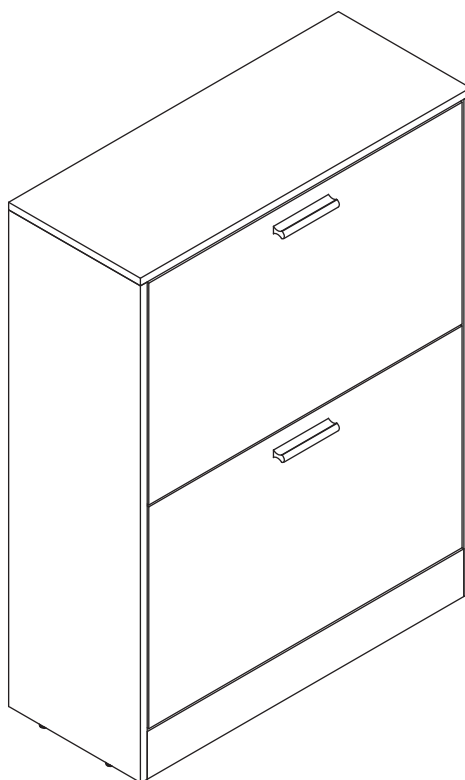

Tools Recommended

THIS INSTRUCTIONS CONTAINS IMPORTANT SAFETY INFORMATION.
PLEASE READ BEFORE ASSEMBLY AND KEEP FOR FUTURE REFERENCE.

Need Parts or Assistance? Email us

IMPORTANT NOTICE

-This product contains small components, please ensure that they are kept away from small children.

-THIS INSTRUCTIONS CONTAINS IMPORTANT SAFETY INFORMATION.
PLEASE READ BEFORE ASSEMBLY AND KEEP FOR FUTURE REFERENCE.

-Read each step carefully. It is very important that each step of instruction is performed in the correct order. If these steps are not followed in sequence, assembly difficulties will occur.

-Make sure all parts are included. Most parts are labelled or stamped on the raw edge.

-Work in spacious area, preferably on a carpet, near the place the unit will be used.

-Do not use power tools to assemble your furniture. Power tools may strip or damage the parts.

-Move your new furniture carefully, with two people lift and carry the unit to it's new location.

-Never push, drag or pull your furniture (especially on carpet)



PLEASE DO NOT RETURN PRODUCT TO US IMMEDIATELY

If a part is missing or damaged, email our customer service.
We will gladly ship your replacement parts FREE of charge.

Need Parts or Assistance? Email us

For Prompt, reliable service, please have your assemble instruction ready

 WARNING	
	Children have died from furniture tipover. To reduce the risk of furniture tipover: <ul style="list-style-type: none">• ALWAYS install anti-tip device provided.• NEVER put a TV on this product.• NEVER allow children to stand, climb or hang on any drawers, doors, or shelves.• NEVER open more than one drawer at a time.• Place heaviest items in the lowest drawers.
	<p>This is a permanent label. Do not remove!</p>

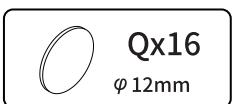
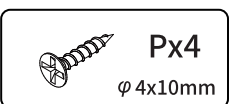
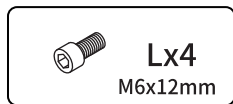
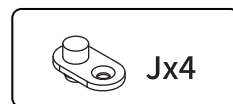
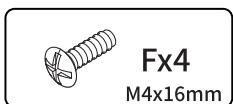
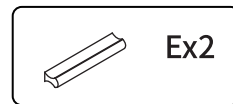
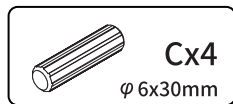
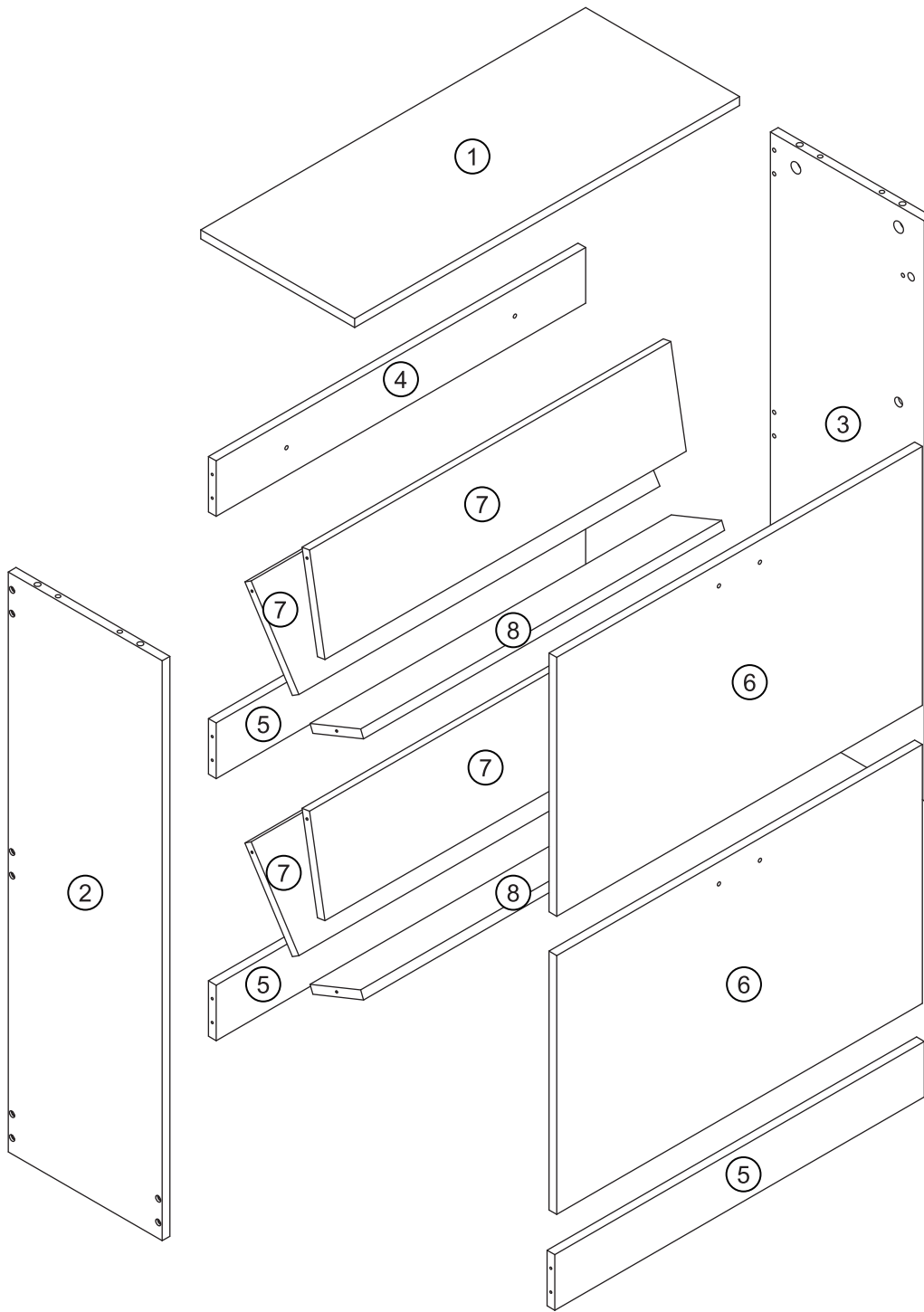

Step 1 Lock screw (A) on the part ①, then use screw (P) to install plastics (J) onto parts ② and ③.
The installation position is as shown in the figure below.

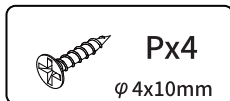
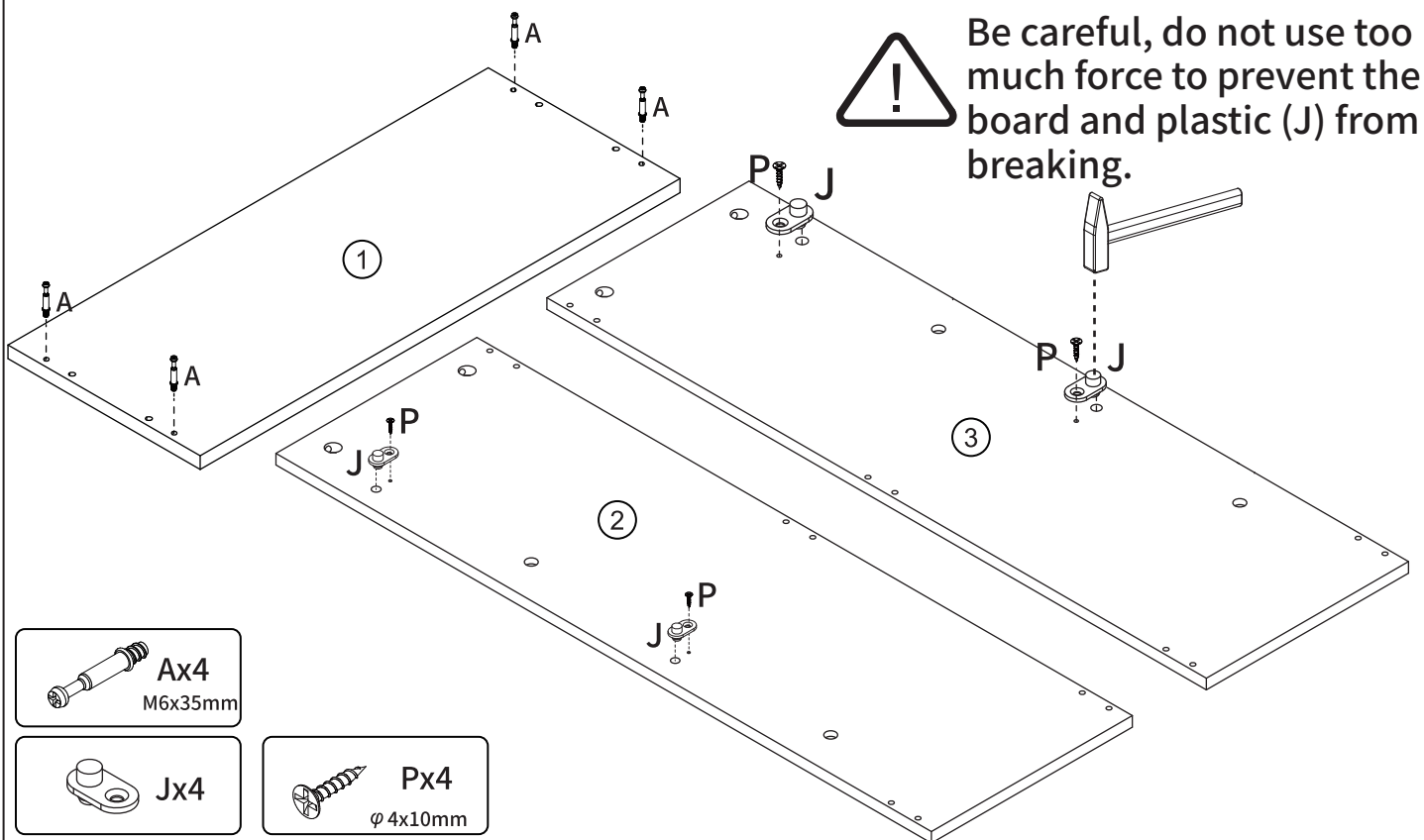

Step 2

Assemble Part ④ and ⑤ to Part ② with screw (M) .
Part (Q) is hole sticker, you can use to cover the hole.
The installation position is as shown in the figure below.

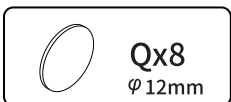
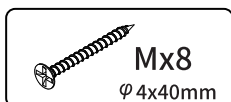
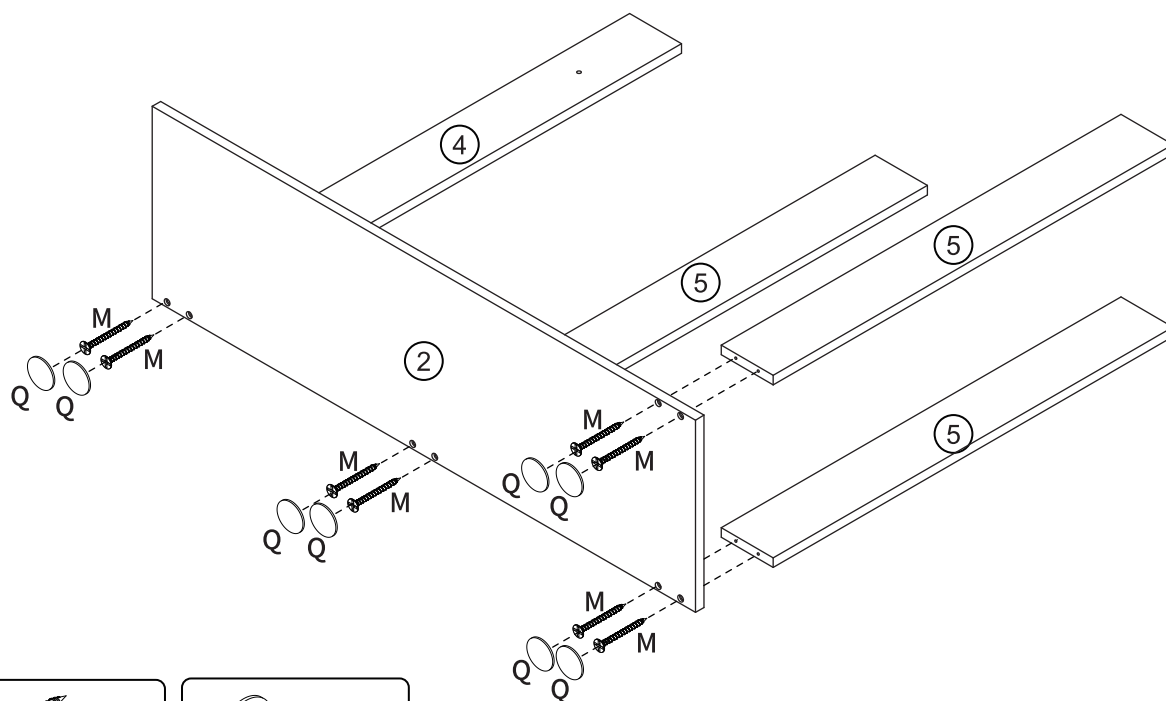

Step 3

Assemble Part ④ and ⑤ to Part ③ with screw (M) .
Part (Q) is hole sticker, you can use to cover the hole.
The installation position is as shown in the figure below.

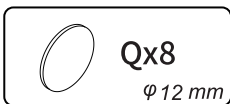
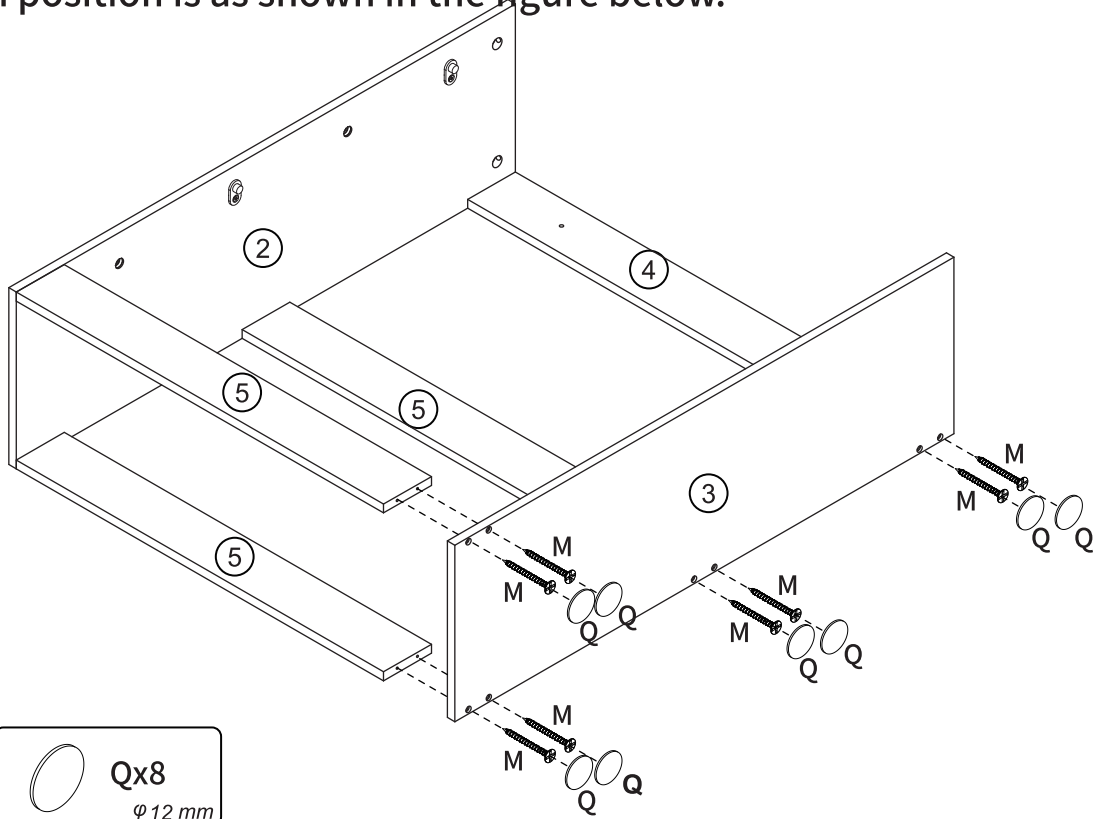

Step 4

Insert the dowel (C) into part ②, ③ first , then assemble parts ②, ③, and part ①,
put the eccentric (B) into the corresponding hole and use a flat-blade
screw driver to turn it clockwise to tighten . Install the foot pad (O) in
the appropriate position for the parts ② and ③.
The installation position is as shown below.

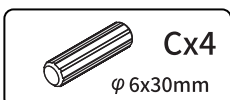
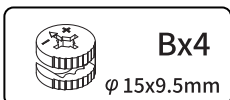
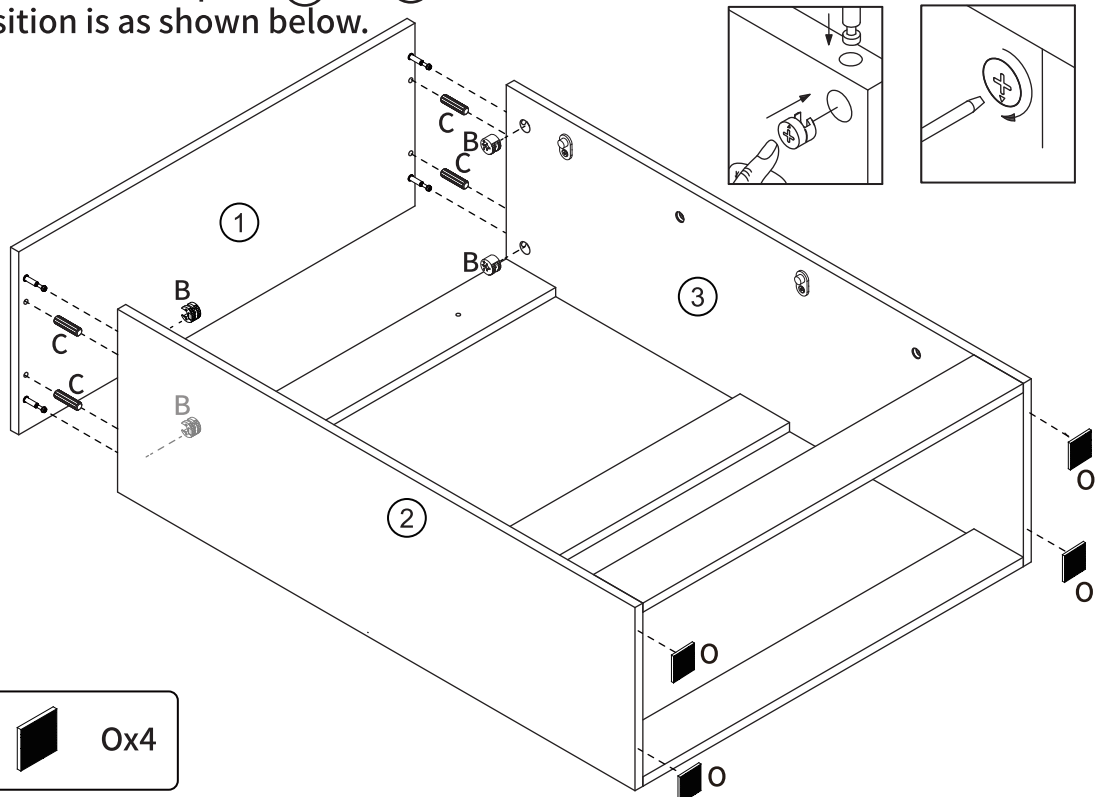

Step 5

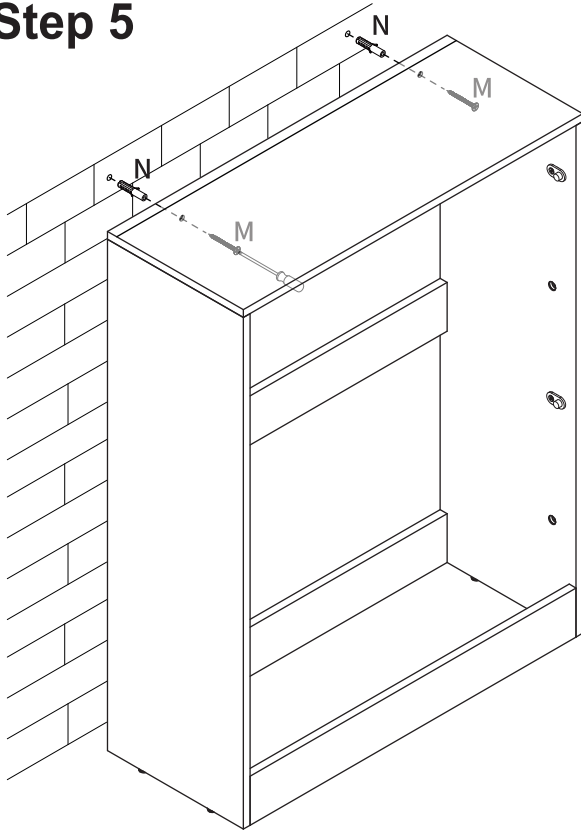

Firstly, determine the hole position of the wall, drill holes in the hole position, and insert the expansion screw (N) into the face of the wall.

Secondly, place the back of the shoe cabinet against the wall, and insert the screw (M) through the pilot hole on the part ④ and into the expansion screw (N).

The installation position is as shown in the figure below.

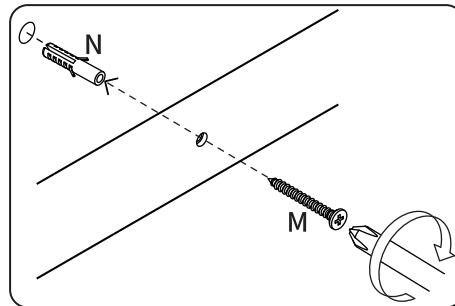

Step 6

Firstly, assemble (H) and (G) on the part ⑥ with screw (D), then install handle (E) on the part ⑥ with screw (F).

The installation position is as shown in the figure below.

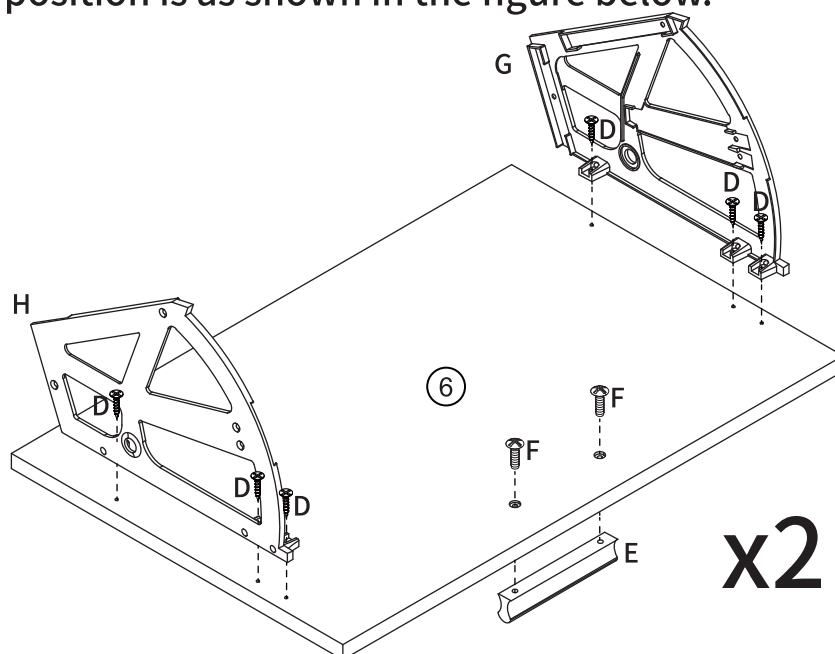

Step 7

Install the parts ⑦ and ⑧ on (H) and (G) using screw (D).
The installation position is as shown in the figure below.

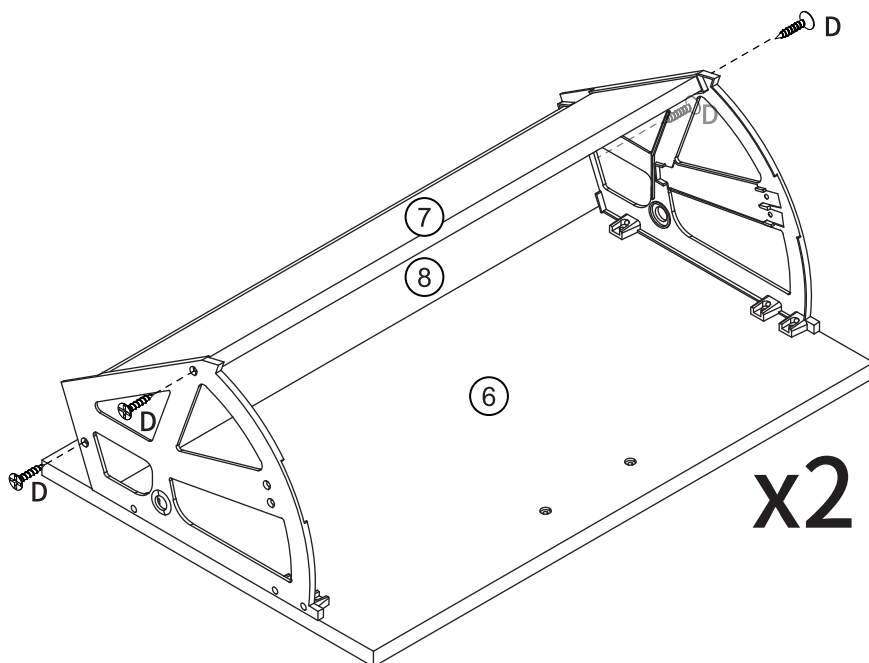

Step 8

Install plastics (K) as shown, then lock it on parts ② and ③ using screw (L) and wrench (I).
The installation position is as shown in the figure below.

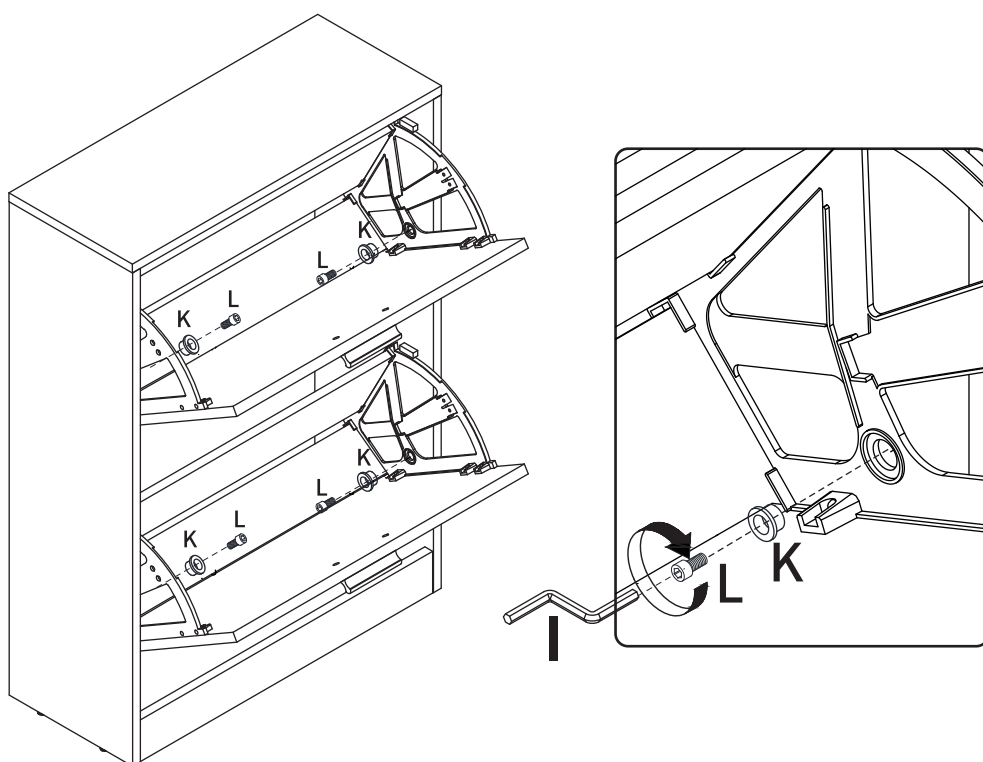

Step 9

Fasten the part ⑦ to (H) and (G) with screw (D).
The installation position is as shown below.

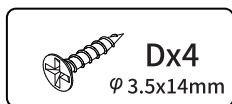
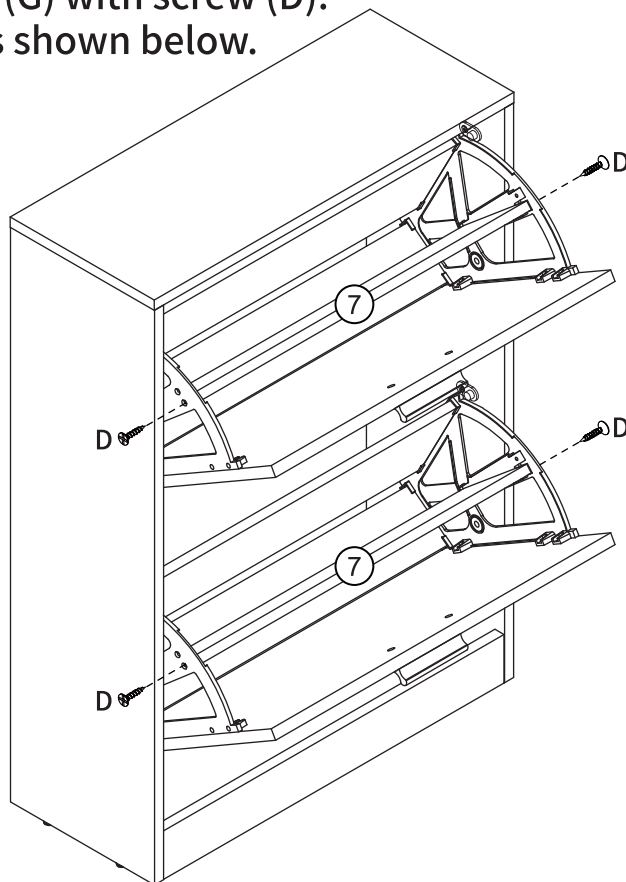

Step 10

