

ASSEMBLY INSTRUCTIONS

NO	PART LIST	QTY
A	HEADBOARD	1
B	FOOTBOARD	1
C	SIDE RAIL	2
D	SLAT	12
E	LONG SUPPORT	1
F	CENTER SUPPORT	3

NO	HARDWARE LIST	QTY
1	JCBC M6 X 90MM 	8
2	BARREL NUT 	8
3	CSK SCREW M4 X 32MM 	8
4	WOOD DOWEL M10 X 30MM 	4
5	ALLEN KEY 	1
6	JCBC M6 X 60MM 	3

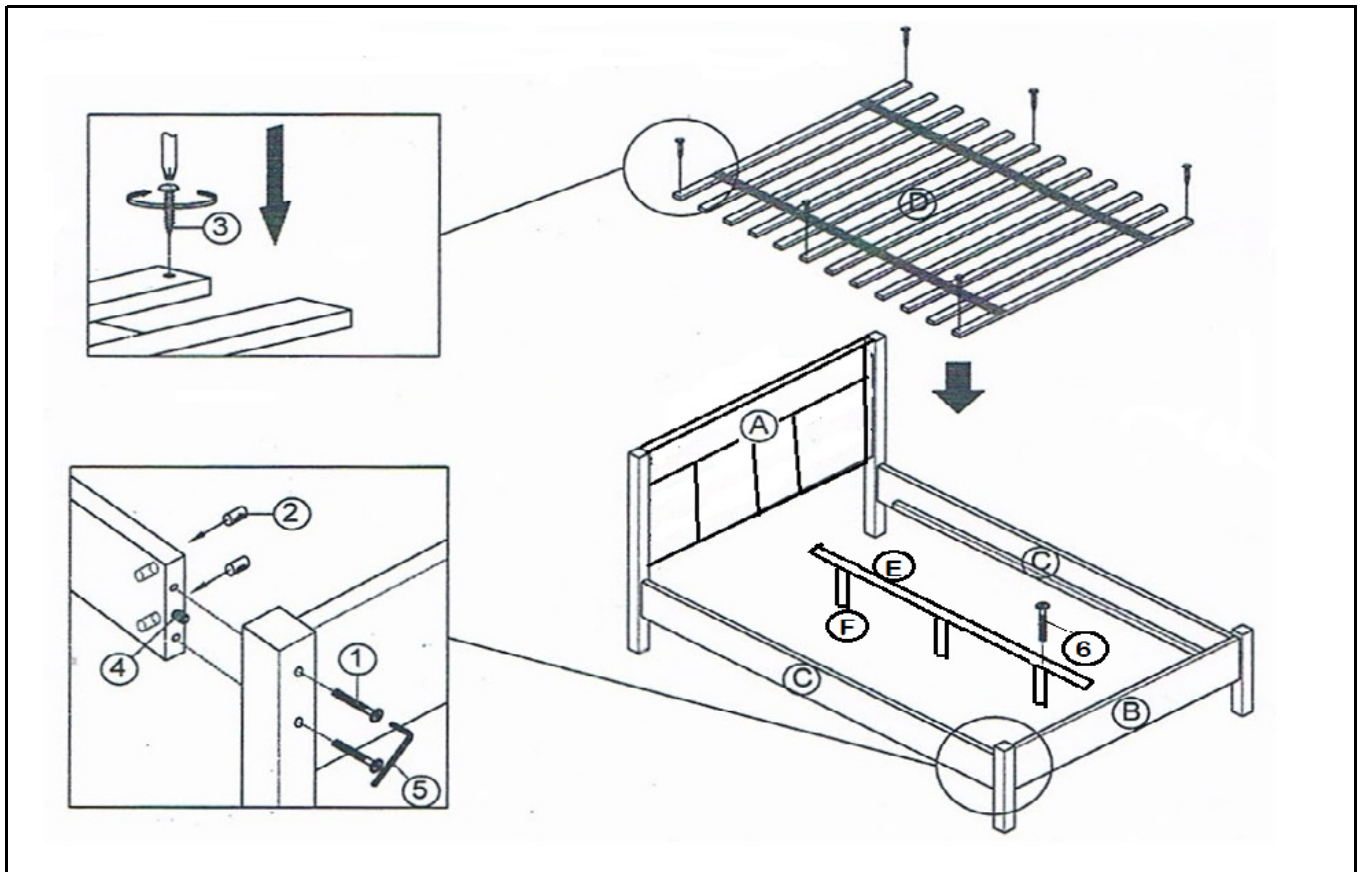

COMPLETE ASSEMBLY

