

- EN** - Please read this instruction manual carefully before attempting to install.
- DE** - Bitte lesen Sie diese Bedienungsanleitung vor der Montage gründlich durch.
- ES** - Por favor lea con atención el manual de instrucciones antes de llevar a cabo el ensamble.
- FR** - Lisez attentivement cette notice avant de commencer le montage.
- IT** - Si prega di consultare il libretto delle istruzioni prima del montaggio.

IMPORTANT/WICHTIG/ATENCIÓN

IMPORTANT/IMPORTANTE



EN - We recommend **1** or more people to install.
DE - Wir empfehlen, dass die Montage von **1** oder mehreren Personen durchgeführt werden sollte.
ES - Recomendamos realizar el ensamble con **1** o más personas.
FR - Il est recommandé d'effectuer le montage à **1** personne(s) ou plus.
IT - È necessaria la presenza di **1** o più persone per il montaggio di questo prodotto.



EN - The expected assembly time is **1 h**.
DE - Die Montagezeit beträgt durchschnittlich **1 h**.
ES - El tiempo aproximado de ensamble es de **1 h**.
FR - Le temps nécessaire est estimé à **1 h**.
IT - Il tempo previsto per il corretto assemblaggio è di **1 h**.



EN - Not intended for use by children.
DE - Nicht geeignet für Kinder.
ES - Producto no apto para niños.
FR - Produit non destiné à être utilisé par des enfants.
IT - Questo prodotto non è destinato all'uso da parte dei bambini.









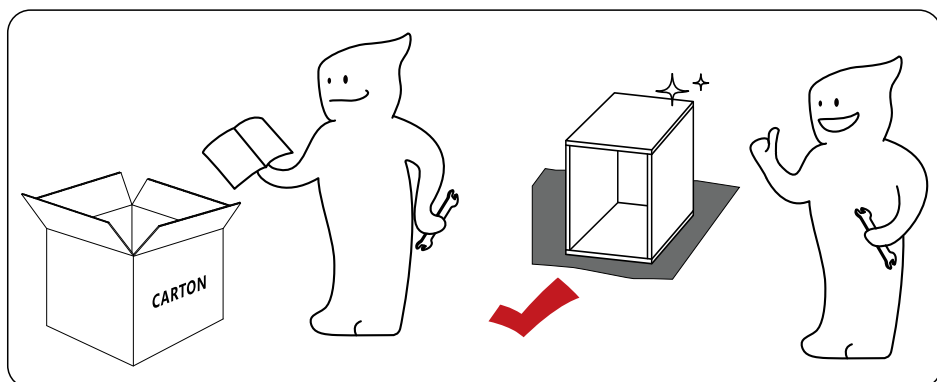
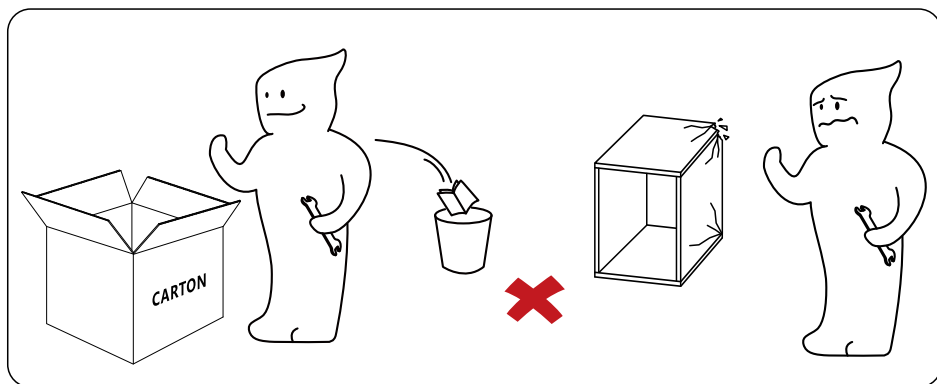

EN - Keep away from fire or other heat sources.
DE - Bitte von Feuer und Hitzequellen fernhalten.
ES - Manténgase alejado de las llamas y otras fuentes de calor.
FR - Tenir à distance des flammes et autres sources de chaleur.
IT - Tenere lontano dal fuoco o da altre fonti di calore.

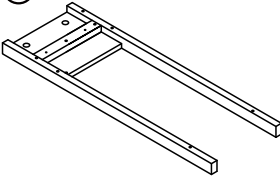
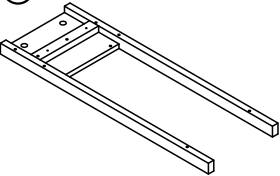
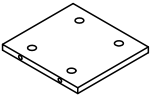
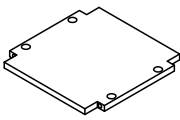
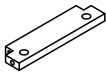
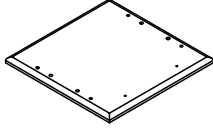
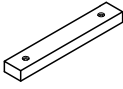
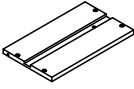
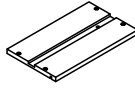
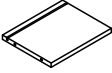
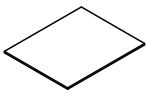
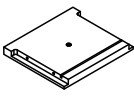
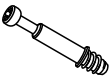

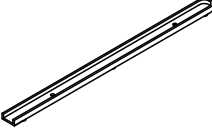
EN - We recommend wearing protective gloves.
DE - Wir empfehlen das Tragen von Schutzhandschuhen.
ES - Recomendamos el uso de guantes de seguridad.
FR - Il est recommandé de porter des gants de protection.
IT - Per il processo di assemblaggio, consigliamo fortemente l'utilizzo di guanti protettivi.

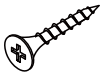
- EN** - Please follow the instruction manuals and use a pad to avoid damage during assembly.
- DE** - Bitte folgen Sie der Anleitung und verwenden Sie eine Unterlage, um Beschädigungen bei der Montage zu vermeiden.
- ES** - Por favor, siga las instrucciones del manual y utilice una cubierta o lona para proteger el producto y el suelo durante la instalación.
- FR** - Suivez les instructions de la notice et utilisez une couverture ou une bâche pour protéger le produit et les sols pendant le montage.
- IT** - Si prega di consultare il manuale illustrativo durante il montaggio e di utilizzare un cuscinetto per evitare possibili danni.

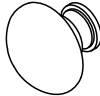

<p>① × 2</p> <p>L</p> 	<p>② × 2</p> <p>R</p> 	<p>③ × 2</p> 		
<p>④ × 2</p> 	<p>⑤ × 2</p> 	<p>⑥ × 2</p> 		
<p>⑦ × 2</p> 	<p>⑧ × 2</p> <p>L</p> 	<p>⑨ × 2</p> <p>R</p> 	<p>⑩ × 2</p> 	
<p>⑪ × 2</p> 	<p>⑫ × 2</p> 	<p>Ⓐ × 28</p> 	<p>Ⓑ × 28</p> 	
<p>Ⓒ × 12</p> 	<p>Ⓓ × 4</p> 	<p>Ⓔ × 8</p> 	<p>Ⓕ × 4</p> 	
<p>Ⓖ × 16</p> 	<p>Ⓗ × 2</p> 	<p>Ⓘ × 2</p> 	<p>Ⓝ × 4</p> 	<p>Ⓚ × 2</p> 

EN - Extra accessories are included. Please use the extra accessories if the original accessories are missing or damaged.

DE - Zusätzliches Zubehör ist im Lieferumfang enthalten. Bitte verwenden Sie das zusätzliche Zubehör, wenn das Originalzubehör fehlt oder beschädigt ist.



ES - Se incluyen accesorios adicionales. Utilice los accesorios adicionales si los accesorios originales faltan o están dañados.

FR - Des éléments supplémentaires sont inclus. Veuillez les utiliser si les éléments d'origine sont manquants ou défectueux.

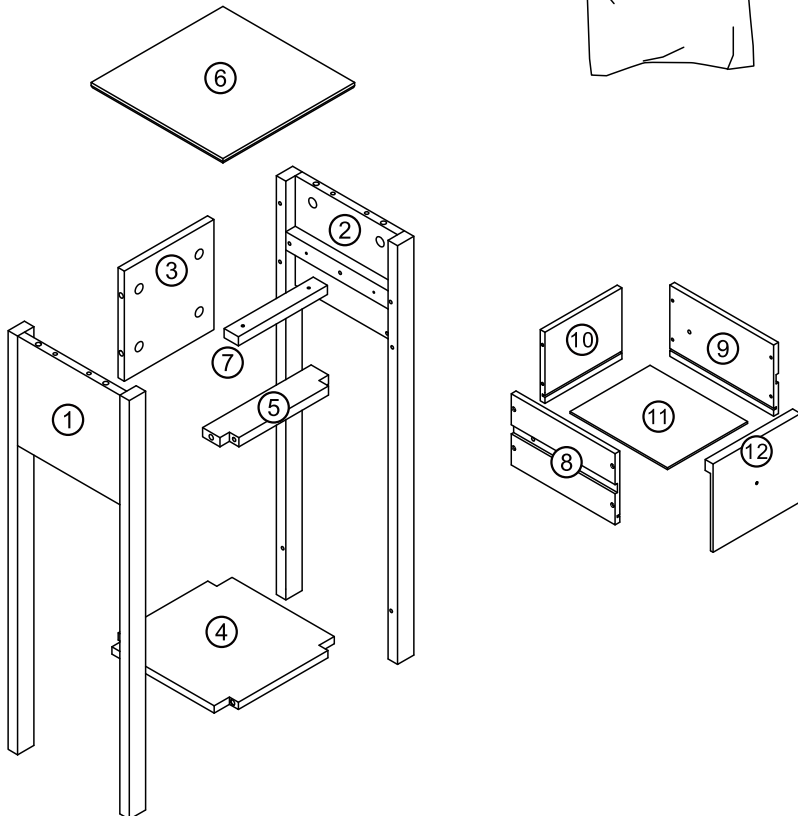
IT - Gli accessori extra sono inclusi. Si prega di utilizzare gli accessori extra se gli accessori originali risultano mancanti o danneggiati.



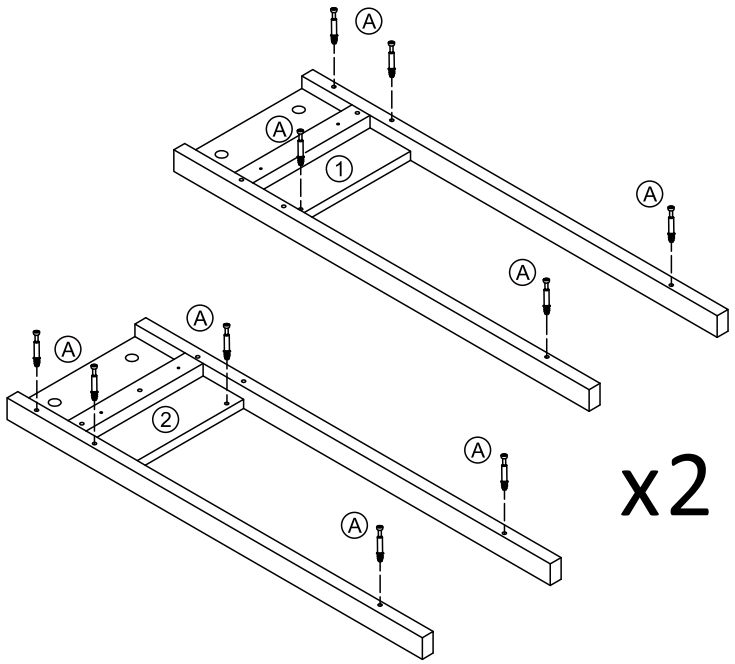

1

①		x1
②		x1
Ⓐ		x10





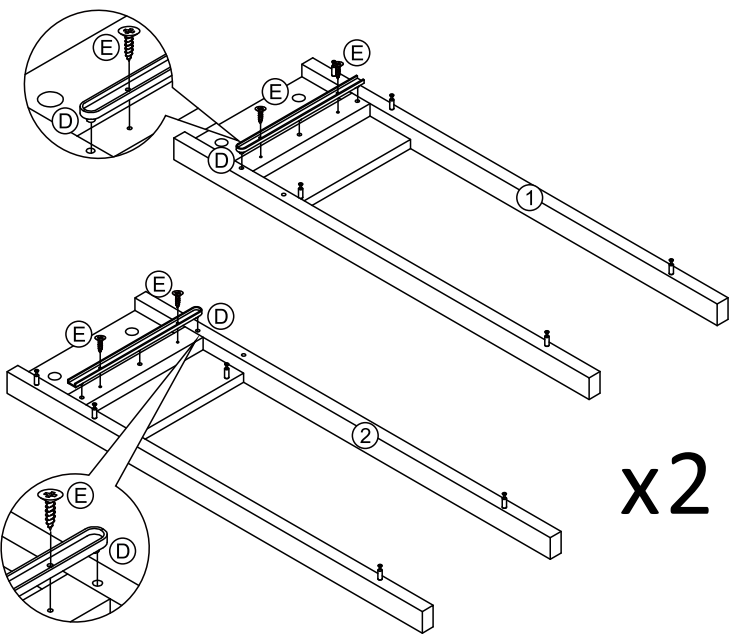

2

Ⓓ		x2
Ⓔ		x4

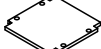

3

③		x1	④		x1	⑤		x1	Ⓑ		x5
Ⓒ		x1									

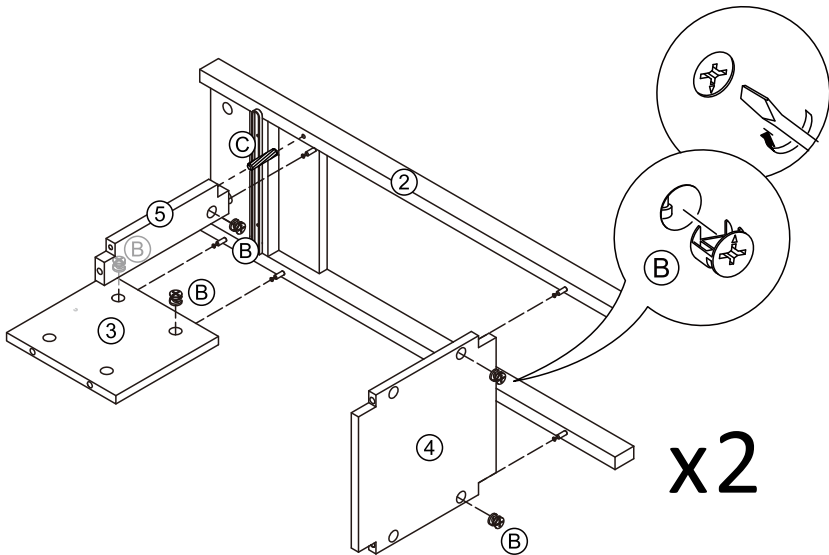

EN - Please pay attention to the direction of part 3. The side with a hole for anti-tip fitting faces up.





DE - Achten Sie bitte auf die Richtung von Teil 3. Die Seite mit der Bohrung für den Kippschutzbeschlag sollte nach oben gezeigt werden.

ES - Al montar el elemento 3, el lado con el orificio anti-vuelco debe estar orientado hacia arriba.

FR - Attention lors du montage de l'élément 3, le côté avec un trou anti basculement doit être placé vers le haut.

IT - Si prega di fare attenzione al verso della parte 3. Il lato con una fessura destinata alla giunzione antiribaltamento è rivolto verso l'alto.

5

⑥		x1
Ⓐ		x4
Ⓑ		x4
Ⓒ		x4

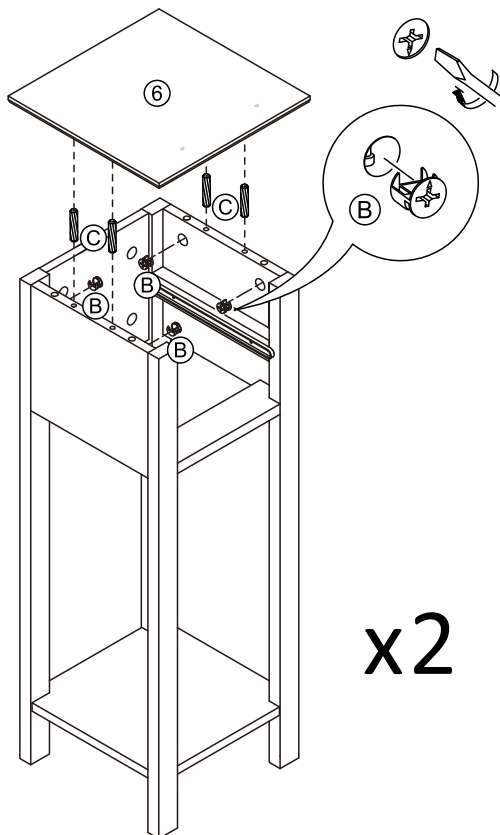
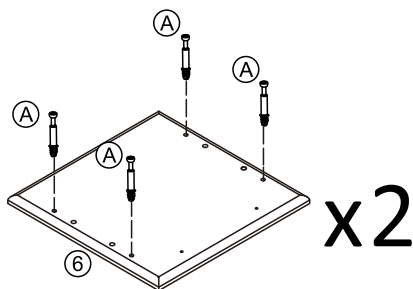

EN - Please distinguish the front and back direction of Part 6. There should be 2 holes under the front of the board (Part 6).



DE - Bitte unterscheiden Sie die Vorder- und Rückrichtung von Teil 6. Es sollten 2 Löcher unter der Vorderseite der Platte (Teil 6) sein.

ES - Tenga cuidado de diferenciar entre la parte delantera y la trasera del elemento 6. Debe haber 2 agujeros debajo de la parte delantera del tablero (elemento 6).



FR - Attention de bien différencier l'avant et l'arrière de l'élément 6. Il doit y avoir 2 trous sous l'avant de la planche (élément 6).

IT - Si prega di distinguere il verso anteriore e posteriore della parte 6. Dovrebbero esserci due fessure sotto il lato anteriore della tavola (parte 6).



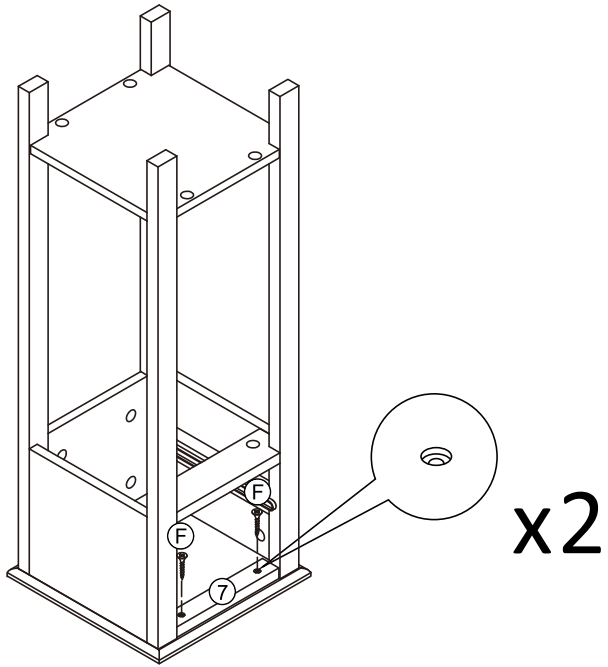

6

⑦	 x1
ⓕ	 x2





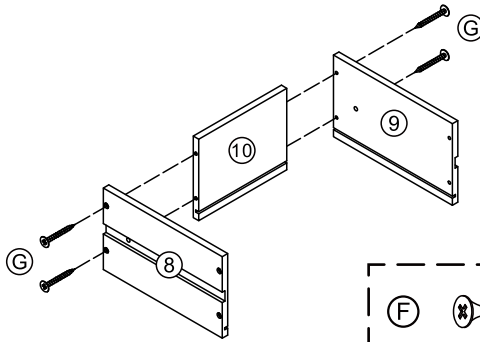

ⓕ		✓
ⓐ		✗

7



⑧		x1
⑨		x1
⑩		x1
Ⓒ		x4



x2

Ⓕ		
Ⓒ		



8

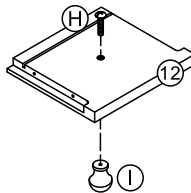



⑫		x1
Ⓗ		x1
①		x1



x2

9

⑪		x1
Ⓒ		x4

Ⓕ		
Ⓒ		

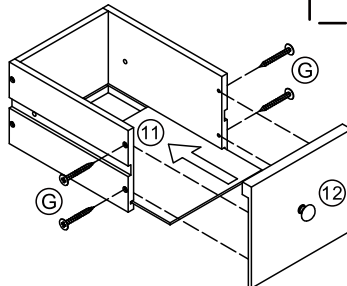

x2

10

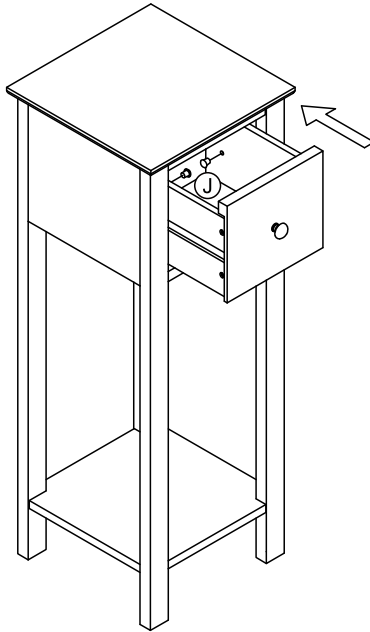

11

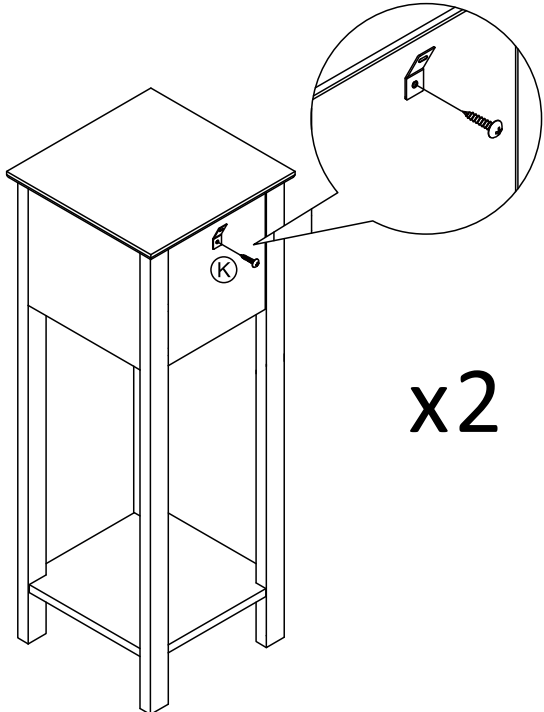

12

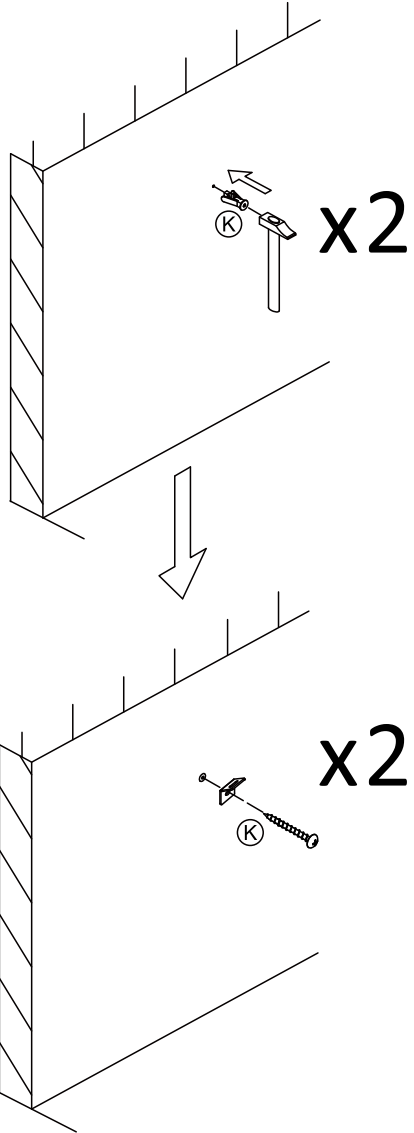
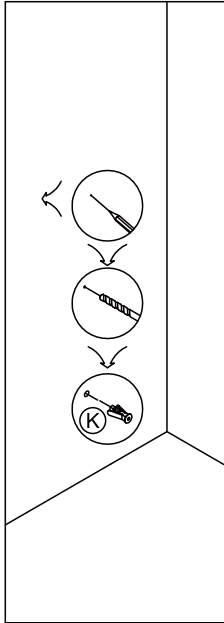

13

