

MANUAL DE MONTAJE
 NOTICE DE MONTAGE
 ASSEMBLY MANUAL
 MANUALE PER IL MONTAGGIO
 MONTAGEANLEITUNG
 MANUAL DE MONTAGEM
 INSTRUKCJE MONTAŻOWE

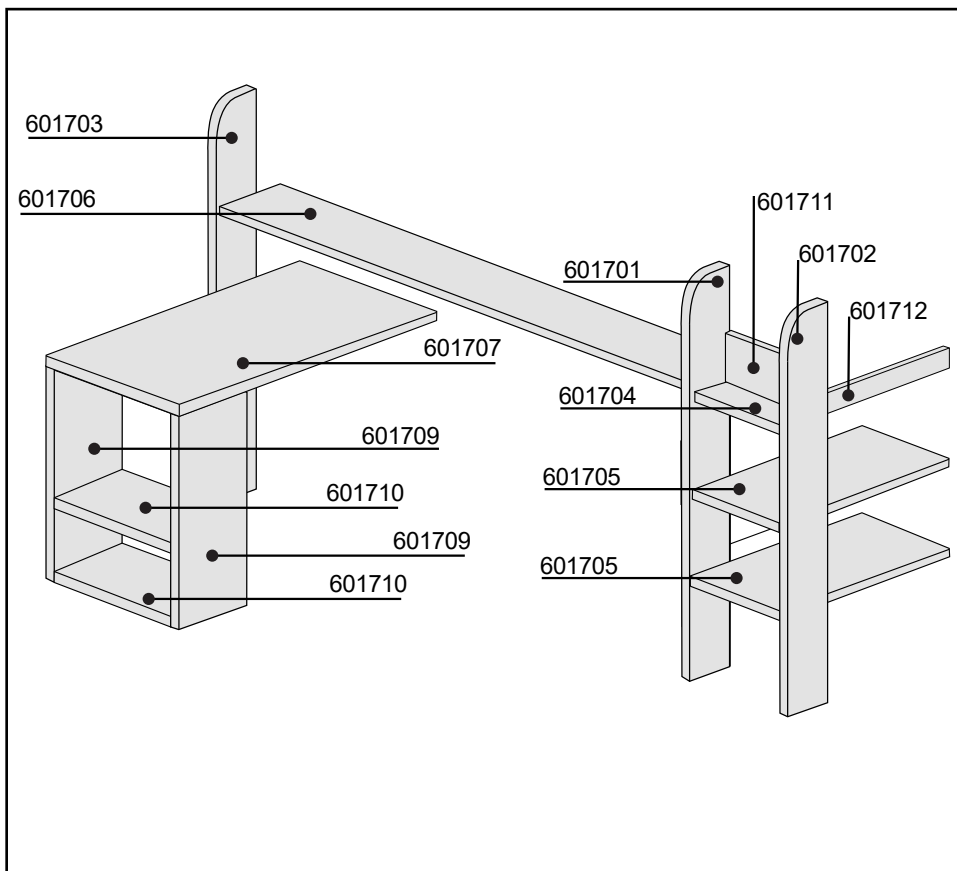
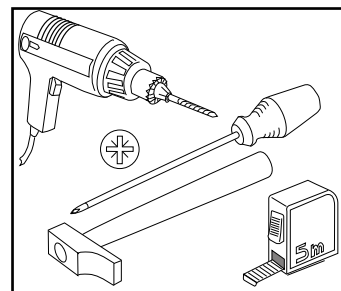
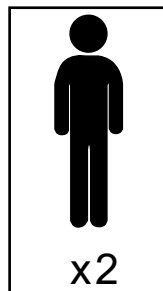
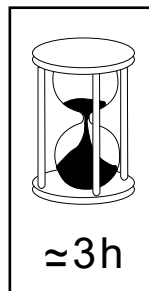
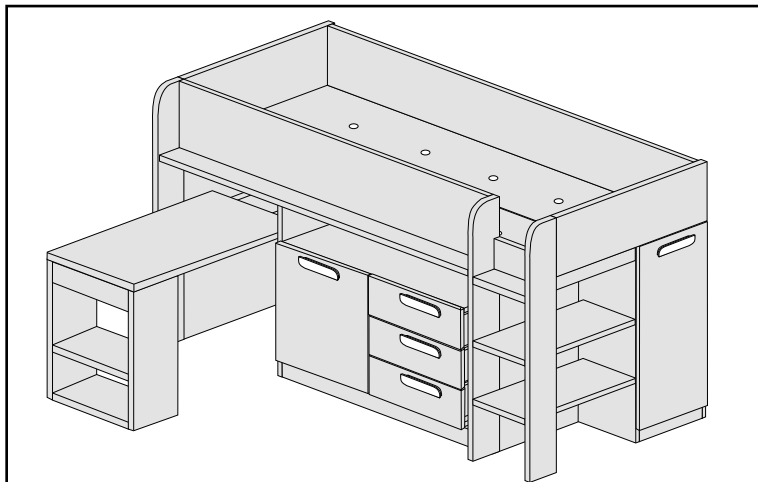

ANTES DE EMPEZAR
 CONSULTE LOS CONSEJOS
 PARA EL MONTAJE.

AVANT DE COMMENCER
 CONSULTEZ LES
 INSTRUCTIONS DE MONTAGE.

BEFORE STARTING REFER TO
 THE ASSEMBLY ADVICE.

PRIMA DI INIZIARE LEGGERE
 I CONIGLI PER IL MONTAGGIO.

VOR DEM BEGINN EMPFIEHLT
 ES SICH AUFMERKSAM DIE
 HINWEISE ZUR MONTAGE ZU
 LESEN.

ANTES DE COMEÇAR
 CONSULTE OS CONSELHOS
 PARA A MONTAGEM .

ZANIM PRZYSTĄPIMY DO
 MONTAŻU , PROSIMY
 ZAPOZNAĆ SIĘ Z
 NASTĘPUJACYMI
 WSKAZÓWKAMI.

x17	x8	x5	x5
T8PC	TA4PC	TE17PC	T5PC

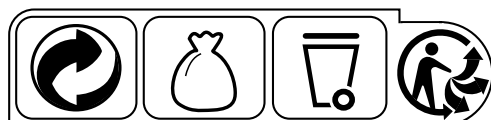

ESPAÑOL

CONSEJOS PARA EL MONTAJE:

- 1-ESTUDIE ATENTAMENTE EL MANUAL DE MONTAJE.
- 2-LOCALICE LAS PIEZAS QUE CONSTITUYEN SU MUEBLE.
- 3-REUNA Y CONTROLE LOS HERRAJES SUMINISTRADOS.
- 4-EQUIPESE CON LAS HERRAMIENTAS NECESARIAS.
- 5-PREPARE UNA ZONA DE MONTAJE.

CONSEJOS PARA EL MANTENIMIENTO:

- 1-QUITAR EL POLVO CUIDADOSAMENTE.
- 2-HUMEDECER UN PAÑO SUAVE Y LIMPIO CON AGUA LIGERAMENTE ENJABONADA.

NO FUERCE NUNCA EN LAS UNIONES APRIETE LOS TORNILLOS DESPUES DE CIERTO TIEMPO DE UTILIZACION.
CONSERVE SU MANUAL DE MONTAJE.SI FALTARA UNA PIEZA SERIA LA MANERA MAS FACIL DE COMUNICARLO A LA TIENDA.

NO USE NUNCA PRODUCTOS ABRASIVOS TALES COMO:
LANA DE ACERO , LIJAS,DISOLVENTES,ETC.
NO MOJAR NI SOMETER A GRANDES HUMEDADES AL MUEBLE.

FRANCAIS

INSTRUCTIONS DE MONTAGE:

- 1-LISEZ ATTENTIVEMENT LA NOTICE DE MONTAGE.
- 2-REPEREZ LES PIECES QUI COMPOSENT VOTRE MEUBLE.
- 3-REGROUPEZ ET VERIFIEZ LES FERRURES FOURNIES.
- 4-DOTEZ-VOUS DES OUTILS NECESSAIRES.
- 5-PREPAREZ UN ESPACE DE MONTAGE.

CONSEILS D'ENTRETIEN:

- 1-ENLEVEZ SOIGNEUSEMENT LA POUSSIERE.
- 2-HUMIDIFIEZ UN CHIFFON DOUX ET PROPRE AVEC DE L'EAU LEGEREMENT SAVONNEUSE.

NE FORCEZ JAMAIS LES RACCORDS. RESSERREZ LES VIS APRES UN CERTAIN TEMPS D'UTILISATION.
CONSERVEZ LA NOTICE DE MONTAGE.EN CAS DE PIECE MANQUANTE , CE SERA LE MEILLEUR MOYEN D'EN INFORMER LE MAGASIN.

N'UTILISEZ JAMAIS DES PRODUITS ABRASIFS COMME DE LA LAINE D'ACIER, DU PAPIER DE VERRE, DES SOLVANTS, ETC.
NE MOUILLEZ PAS LE MEUBLE ET EVITEZ TOUTE ESPOSITION A UNE HUMIDITE IMPORTANTE.

DEUTSCH

HINWEISE ZUR MONTAGE:

- 1- LESEN SIE AUFMERKSAM DIE MONTAGEANLEITUNG DURCH.
- 2- LOKALISIEREN SIE DIE ZUM MÖBEL GEHÖRENDE TEILE.
- 3- KONTROLLIEREN SIE DIE MITGELIEFERTEN WERKZEUGE.
- 4- RÜSTEN SIE SICH MIT DEN ZUSÄTZLICH BENÖTIGTEN WERKZEUGEN AUS.
- 5- BEREITEN SIE EINEN PLATZ FÜR DIE MONTAGE VOR.

HINWEISE ZUR PFLEGE:

- 1- ENTFERNEN SIE UMSICHTIG DEN ANGESAMMELTEN STAUB.
- 2- VERWENDEN SIE EIN WEICHES UND SAUBERES TUCH UND SCHWACHE SEIFENLAUGE.

FORCIEREN SIE NIEMALS DIE VERBINDUNGEN. ZIEHEN SIE DIE SCHRAUBEN NACH EINER BESTIMMTEN NUTZUNGSZEIT NACH.
BEWAHREN SIE DIE MONTAGEANLEITUNG AUF. SOLLTE EIN TEIL FEHLEN IST SIE VON GROSSER WICHTIGKEIT BEI DER NACHBESTELLUNG IM LADEN.

VERWENDEN SIE NIEMALS SCHEUERENDE PRODUKTE WIE STAHLWOLLE, SCHMIRGELPAPIER, LÖSUNGSMITTEL UND DERGL.
WASSER UND HOHE FEUCHTIGKEIT SIND SCHÄDLICH FÜR DAS MÖBEL

ITALIANO

CONSIGLI PER IL MONTAGGIO:

- 1- STUDIARE ATTENTAMENTE IL MANUALE DI MONTAGGIO.
- 2- INDIVIDUARE LE PARTI CHE COSTITUISCONO IL MOBILE.
- 3- RACCOGLIERE E CONTROLLARE GLI ATTREZZI IN DOTAZIONE.
- 4- PROCURARSI GLI ATTREZZI NECESSARI.
- 5- PREPARARE UNA ZONA PER IL MONTAGGIO.

CONSIGLI PER LA MANUTENZIONE:

- 1- SPOLVERARE ACCURATAMENTE.
- 2- INUMIDIRE UN PANNO MORBIDO E PULITO CON ACQUA E POCO DETERGENTE.

NON FORZARE MAI LE GIUNTURE. STRINGERE NUOVAMENTE LE VITI DOPO UN CERTO PERIODO D'USO.
CONSERVARE IL MANUALE DI MONTAGGIO: SE MANCASSE UN PEZZO SAREBBE COSÌ PIÙ FACILE COMUNICARLO AL RIVENDITORE.

NON USARE MAI PRODOTTI ABRASIVI COME: SPUGNE ABRASIVE, CARTA VETRATA, SOLVENTI, ECC.
NON BAGNARE NE' SOTTOPORRE IL MOBILE A FORTE UMIDITÀ.

POTUGUES

CONSELHO PARA A MONTAGEM :

- 1 - ESTUDE ATENTAMENTE O MANUAL DE MONTAGEM.
- 2 - LOCALIZE AS PEÇAS QUE CONSTITUEM O SEU MÓVEL.
- 3 - REUNA E CONTROLE AS FERRAGENS FORNECIDAS.
- 4 - EQUIPE-SE COM AS FERRAMENTAS NECESSÁRIAS.
- 5 - PREPARE UMA ZONA DE MONTAGEM.

CONSELHOS PARA A MANUTENÇÃO :

- 1- RETIRAR A POEIRA COM CUIDADO.
- 2- HUMEDECER UM PANO SUAVE E LIMPO COM ÁGUA LIGEIRAMENTE ENSABOADA.

NUNCA FORCE AS UNIÕES. APORTE OS PARAFUSOS DEPOIS DE DETERMINADO TEMPO DE UTILIZAÇÃO..
CONSERVE O SEU MANUAL DE MONTAGEM, SE FALTAR UMA PEÇA SERIA A MANEIRA MAIS FÁCIL DE A COMUNICAR À LOJA.

NUNCA USE PRODUTOS ABRASIVOS TAIS COMO : LÃ DE AÇO, LIXAS, DISSOLVENTES, ETC..
NÃO MOLAR NEM SUBMETTER A GRANDES HUMIDADES, O MÓVEL.

POLSKU

WSKAZÓWKI ODNOŚNIE MONTAZU:

1. PRZECZYTAĆ UWAGNIE NINIEJSZE ZALECENIA.
2. ZLOKALIZOWAĆ CZĘŚCI SKŁADOWE MEBLA.
3. ZEBRAC WSZYSTKIE ELEMENTY ŁĄCZĄCE.
4. ZAOPATRZYĆ SIĘ W NIEZBEDNE NARZĘDZIA.
5. PRZYGOTOWAĆ ODPOWIEDNIE MIEJSCA NA MONTAZ.

WSKAZÓWKI ODNOŚNIE KONSERWACJI:

1. ODKURZAC OSTROŻNIE.
2. W TYM CELU ZWILŻYC CZYSTĄ MIEKKĄ SZMATKĘ W SŁABYM ROZTWORZE WODY Z MYDLEM.

NIE DOCISKAC NA SIŁE ELEMENTÓW ŁĄCZĄCYCH. DOKRECIĆ SRUBY PO UPŁYWIE PEWNEGO CZASU.
ZACHOWAĆ INSTRUKCJE MONTAZOWE; W RAZIE BRAKU JAKIEJS CZĘŚCI, UŁATWIA ONE KONTAKT ZE SPRZEDAWCĄ.

NIE NALEŻY NIGDY UŻYWAĆ ŚRODKÓW SZORUJĄCYCH, TAKICH JAK WELNA STAŁOWA, PAPIER SCIERNY, ROZPUSZCZALNIKI ITP.
NIE MOCZYĆ ANI NIE PODDAWAĆ MEBLA DZIAŁANIU DUŻEJ WILGOTNOŚCI.

ENGLISH

ASSEMBLY ADVICE:

- 1- STUDY THE ASSEMBLY MANUAL CAREFULLY.
- 2- LOCATE THE PARTS THAT COMPRISE YOUR FURNITURE ITEM.
- 3- ORGANISE AND CHECK THE FITTINGS SUPPLIED.
- 4- HAVE THE NECESSARY TOOLS TO HAND.
- 5- PREPARE AN ASSEMBLY AREA.

MAINTENANCE ADVICE:

- 1- REMOVE DUST CAREFULLY.
- 2- MOISTEN A SOFT, CLEAN CLOTH WITH SLIGHTLY SOAPY WATER.

DO NOT FORCE ANY OF THE JOINTS. TIGHTEN THE SCREWS AFTER HAVING USED THE FURNITURE FOR SOME TIME.
KEEP YOUR ASSEMBLY MANUAL. IF ANY PART IS MISSING, IT WILL HELP YOU TO LET THE SHOP KNOW.

NEVER USE ABRASIVE PRODUCTS SUCH AS STEEL WOOL, SANDPAPER, ETC.
DO NOT WET THE FURNITURE OR KEEP IT IN A VERY DAMP PLACE.



MANUAL DE MONTAJE
 NOTICE DE MONTAGE
 ASSEMBLY MANUAL
 MANUALE PER IL MONTAGGIO
 MONTAGEANLEITUNG
 MANUAL DE MONTAGEM
 INSTRUKCJE MONTAŻOWE

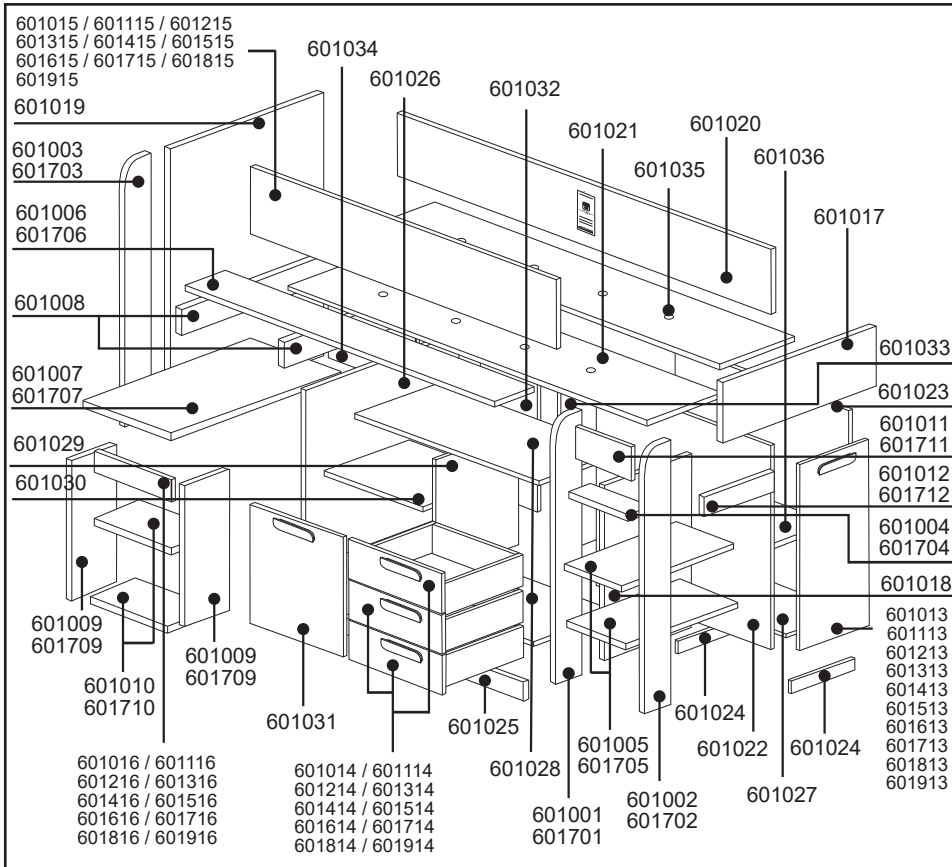
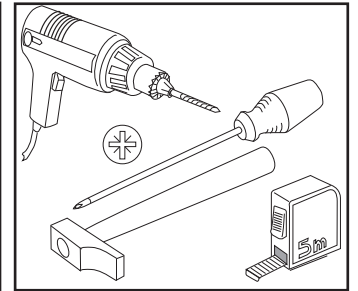
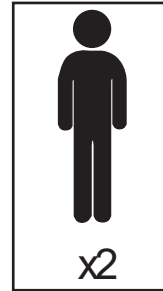
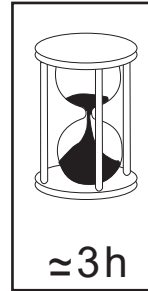
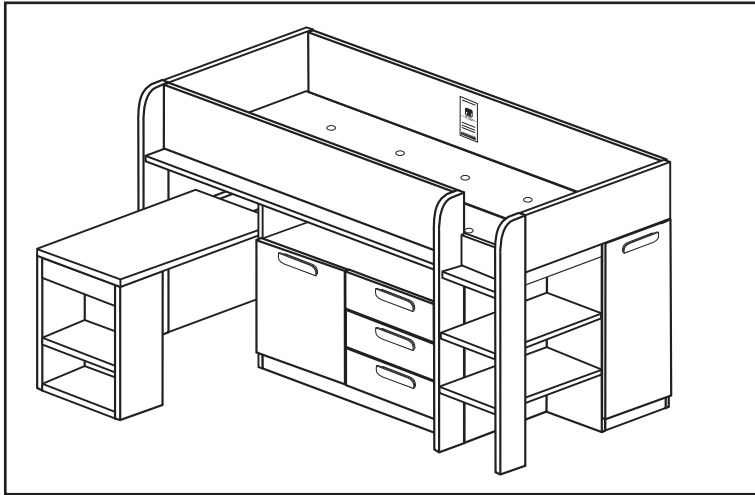

ANTES DE EMPEZAR CONSULTE
 LOS CONSEJOS PARA EL
 MONTAJE.
 AVANT DE COMMENCER
 CONSULTEZ LES INSTRUCTIONS
 DE MONTAGE.
 BEFORE STARTING REFER TO
 THE ASSEMBLY ADVICE.
 PRIMA DI INIZIARE LEGGERE I
 CONIGLI PER IL MONTAGGIO.
 VOR DEM BEGINN EMPFIEHLT ES
 SICH AUFMERKSAM DIE
 HINWEISE ZUR MONTAGE ZU
 LESEN.
 ANTES DE COMEÇAR CONSULTE
 OS CONSELHOS PARA A
 MONTAGEM.
 ZANIM PRZYSTAPIMY DO
 MONTAZU, PROSIMY ZAPOZNAC
 SIE Z NASTĘPUJACYMI
 WSKAZOWKAMI.

x36	x1	x26	x1	x17	x18
TA550	LLA3	TA760	LLA4	TA3BL	TA4BL

x13	x13	x25	x20	x12	x12	x12	x12	x5	x5	x6	x6	x11	x8	x6	x32	
PE845	EX25	CL830	TSM	SKM16	TCK0311	C1070	TV3135	EN3125	TEN513	TUEM61013	TM660A	TUM4	TP3540	T2027CA	TP3515	
x3	x8	x2	x4	x4	x8	x4	x1	x2	x2	x1	x2	x4	x8	x1	x4	x2
TV5135	PE3	T5BL	CT8B	B35R	TV3135	BA35S	CT715	TP4016	SBO22P	COLA	RTD20	TP2516	E2136	EA3030	TP3535	P5040

FR - Instructions d'utilisation

IMPORTANT - LIRE ATTENTIVEMENT - A CONSERVER POUR RÉFÉRENCE ULTÉRIEURE

- a) **AVERTISSEMENT** Les lits surélevés et le lit supérieur des lits superposés ne convient pas pour les enfants de moins de six ans en raison du risque de blessures liées à des chutes.
- b) **AVERTISSEMENT** S'ils ne sont pas utilisés correctement, les lits superposés et les lits surélevés peuvent présenter un sérieux risque de blessure par étranglement. Ne jamais attacher ou suspendre des éléments à des parties du lit superposé qui ne sont pas destinés à être utilisés avec ledit lit. Ces éléments comprennent, sans toutefois s'y limiter, les cordes, les ficelles, les cordons, les crochets, les ceintures et les sacs.
- c) **AVERTISSEMENT** Les enfants peuvent se retrouver coincés entre le lit et un mur, une partie d'un toit incliné, le plafond, des meubles adjacents (par exemple, des placards) ou autre. Pour éviter tout risque de blessure grave, la distance entre la barrière de sécurité supérieure et les éléments environnants ne doit pas dépasser 75 mm ou doit être supérieure à 230 mm.
- d) **AVERTISSEMENT** Ne pas utiliser le lit superposé ou le lit surélevé si une pièce de la structure est manquante ou cassée. Les pièces de rechange doivent être demandés auprès du fabricant ou du magasin.
- e) Il est impératif de toujours suivre les instructions de montage et d'utilisation du fabricant.
- f) La taille recommandée de matelas à utiliser avec le lit est de 2000mm x 900mm. Epaisseur du matelas maximum: 150 mm.
- g) Il est nécessaire de ventiler la pièce afin de maintenir un niveau peu élevé d'humidité et d'empêcher le développement de moisissure dans le lit et sa périphérie.
- h) Les dispositifs d'assemblage doivent toujours être convenablement serrés et régulièrement vérifiés. Les resserrer si nécessaire.
- i) Conforme aux exigences européennes de sécurité de la norme NF EN 747+A1: 2015.
- j) La présence d'une veilleuse de nuit peut procurer plus de sécurité à l'enfant couchant dans le lit haut.

PT - Instruções de utilização

IMPORTANTE - LER ATENTAMENTE - A GUARDAR PARA REFERÊNCIA FUTURA

- a) **AVISO** As camas sobre-elevadas e a cama superior dos beliches não são adaptadas para as crianças menores de seis anos devido ao risco de ferimentos ligados a quedas.
- b) **AVISO** Se não forem utilizados correctamente, os beliches e as camas sobre-elevadas podem apresentar um sério risco de ferimento por estrangulamento. Nunca amarrar ou suspender elementos em partes do beliche que não estão destinadas para ser utilizados com a dita cama. Estes elementos incluem, não sendo esta lista exaustiva, as cordas, os fios, os cordões, os ganchos, os cintos e os sacos.
- c) **AVISO** As crianças podem ficar bloqueadas entre a cama e uma parede, uma parte de um telhado inclinado, o teto, móveis adjacentes (por exemplo, armários) ou outro. Para evitar qualquer risco de ferimento grave, a distância entre a barreira de segurança superior e os elementos circundantes não deve ultrapassar 75 mm ou deve ser superior a 230 mm.
- d) **AVISO** Não utilizar o beliche ou a cama sobre-elevada se faltar uma peça da estrutura ou se uma peça estiver partida. As peças sobressalentes devem ser pedidas ao fabricante ou à loja.
- e) É obrigatório seguir sempre as instruções de montagem e de utilização do fabricante.
- f) O tamanho recomendado do colchão a utilizar com a cama é de 2000mmx 900mm, Espessura do colchão máximo : 150 mm.
- g) É necessário ventilar a peça de forma a manter um nível mais elevado de humidade e de impedir o desenvolvimento de bolor na cama e na sua periferia.
- h) Os dispositivos de montagem devem estar sempre apertados e regularmente verificados. Apertá-los se necessário.
- i) Conforme às exigências europeias de segurança da norma EN 747+A1 : 2015.
- j) A presença de uma luz de presença pode dar mais segurança à criança que estiver a dormir na cama de cima.

ES - Instrucciones de empleo

IMPORTANTE - LEA CON ATENCIÓN - CONSERVAR PARA FUTURAS REFERENCIAS.

- a) **ADVERTENCIA** Las camas elevadas y la cama superior de las literas no son convenientes para niños menores de seis años debido al riesgo de lesiones por caída.
- b) **ADVERTENCIA** Si no se emplean correctamente, las camas elevadas y las literas podrían presentar riesgo de lesiones por estrangulación. No enganche o suspenda elementos a las partes de la litera que no estén destinadas a emplearse con la cama. Estos elementos pueden ser, sin que por ello la lista sea limitativa, cuerdas, cintas, cordones, ganchos, cinturones y bolsas.
- c) **ADVERTENCIA** Los niños podrían quedar atrapados entre la cama y la pared, una parte del techo inclinada, el techo, muebles adyacentes (armarios por ejemplo) u otros. Para evitar cualquier riesgo de lesión grave, la distancia entre la barrera de seguridad superior y los elementos que la rodean no deberán superar los 75 mm o ser superiores a 230 mm.
- d) **ADVERTENCIA** No utilice una litera o cama elevada si una pieza de la estructura falta o está dañada. Las piezas de recambio deberán solicitarse al fabricante o a la tienda.
- e) Siempre será obligatorio seguir las instrucciones de montaje y empleo del fabricante.
- f) El tamaño del colchón recomendado para la cama es de 2000mm x 900mm. Espesor máximo del colchón: 150 mm.
- g) También será necesario ventilar la habitación para mantener un nivel de humedad poco elevado y evitar el desarrollo de mohos en la cama y su entorno.
- h) Los dispositivos de ensamblaje deberán apretarse de manera adecuada y comprobarse regularmente. Apretarlos si fuera necesario.
- i) Cumple los requisitos europeos de seguridad de la norma NF EN 747+A1:2015.
- j) Una luz de noche ofrecerá más seguridad al niño que duerma en la cama superior.

EN - Instructions for use

IMPORTANT - READ CAREFULLY - KEEP FOR FUTURE REFERENCE

- a) **WARNING** Raised beds and the upper bed in a bunk bed assembly are not good for children under 6 years old because of the risk of injury from falling from such beds.
- b) **WARNING** If the raised and bunk beds are not used correctly, they can present a serious risk of injury from strangulation. Never attach or suspend things from the upper bunk bed that are not going to be used with that bed. Such things include - but are not limited to - cords, string, sashes, hooks, belts and bags.
- c) **WARNING** Children can find themselves trapped between the bed and wall, or inclined roof wall, ceiling, adjacent pieces of furniture (such as cupboards) or other items. To avoid any risk of serious injury, the distance between the upper safety barrier and surrounding items should not exceed 75 mm - or the distance should be greater than 230 mm.
- d) **WARNING** Do not use the upper bunk bed or a raised bed if a part of the structure is missing or broken. Spare parts should be requested from the manufacturer or shop.
- e) It is essential that the manufacturer's instructions on assembly and use are followed.
- f) The recommended size of the mattress to be used with the bed is 2000mm x 900mm. Maximum mattress thickness: 150 mm.
- g) Mattresses must be aired to maintain a low humidity and to stop moisture building up in the bed and its surroundings.
- h) The fastenings put in place on assembly should all be properly tightened and regularly checked. Retighten the fastenings as necessary.
- i) This complies with the requirements of the European Safety Standard NF EN 747+A1: 2015.
- j) The presence of a night light could give more safety for a child sleeping in an upper bed.

DE - Gebrauchsanweisung

WICHTIG - AUFMERKSAM LESEN - ZUR SPÄTEREN EINSICHTNAHME AUFZUBEWAHREN

- a) **WARNUNG** Hochbetten und das obere Bett bei Etagenbetten sind wegen des Verletzungsrisikos durch Stürze nicht für Kinder unter sechs Jahren geeignet.
- b) **WARNUNG** Wenn sie nicht richtig verwendet werden, können Hochbetten und Etagenbetten ein schweres Verletzungsrisiko durch Strangulierung darstellen. Es dürfen niemals Elemente an Teilen des Hochbetts befestigt oder aufgehängt werden, die nicht zur Verwendung mit besagtem Bett bestimmt sind. Diese Elemente umfassen, sind aber nicht beschränkt auf, Seile, Fäden, Schnüre, Haken, Gürtel und Taschen.
- c) **WARNUNG** Kinder können sich zwischen dem Bett und einer Wand, einer gekippten Wandstelle, der Decke, Möbeln in der Nähe (zum Beispiel Schränke) oder anderem einklemmen. Um jedes Risiko einer schweren Verletzung zu vermeiden, darf der Abstand zwischen der oberen Sicherheitsschranke und den Elementen in der Umgebung 75 mm nicht überschreiten oder muss größer als 230 sein.
- d) **WARNUNG** Das Hochbett oder das Etagenbett darf nicht verwendet werden, wenn ein Teil des Aufbaus fehlt oder beschädigt ist. Ersatzteile müssen beim Hersteller oder im Laden bestellt werden.
- e) Die Montage- und Gebrauchsanweisungen des Herstellers müssen unbedingt immer befolgt werden.
- f) Die empfohlene Größe der mit dem Bett zu verwendenden Matratze beträgt 2000mm x 900 mm, Höchstdicke der Matratze: 150 mm.
- g) Es ist notwendig, den Raum zu lüften, um einen geringen Feuchtigkeitsgrad aufrechtserhalten und die Entwicklung von Schimmel im Bett und seiner Umgebung zu verhindern.
- h) Die Montagevorrichtungen müssen immer angemessen festgezogen und regelmäßig überprüft werden. Wenn nötig, erneut festziehen.
- i) Entspricht den europäischen Sicherheitsanforderungen der Norm EN 747+A1:2015.
- j) Wenn ein Nachtlicht vorhanden ist, kann dies dem im oberen Bett schlafenden Kind mehr Sicherheit geben.

NL - Gebruiksrichtlijnen

BELANGRIJK -AANDACHTIG LEZEN - TE BEWAREN VOOR LATERE RAADPLEGING

- a) **WAARSCHUWING** De verhoogde bedden en het hoge bed van stapelbedden zijn niet geschikt voor kinderen jongeren dan zes omwille van het gevaar op kwetsuren door valpartijen.
- b) **WAARSCHUWING** Wanneer ze niet correct gebruikt worden, kunnen verhoogde bedden en stapelbedden een ernstig gevaar inhouden op kwetsuren door wurging. Nooit dingen bevestigen of ophangen aan delen van het stapelbed die niet bestemd zijn voor gebruik met het desbetreffende bed. Deze elementen omvatten, zonder hiertoe beperkt te zijn, koorden, touwen, snoeren, haken, riemen en zakken of tassen.
- c) **WAARSCHUWING** Kinderen kunnen vast komen te zitten tussen het bed en een muur, een deel van het hellend dak, het plafond, naburige meubels (bijvoorbeeld kasten) of andere zaken. Om elk gevaar op een ernstigen kwetsuur te vermijden, mag de afstand tussen de bovenste veiligheidsstang en de omliggende elementen niet groter zijn dan 75mm of moet deze groter zijn dan 230 mm.
- d) **WAARSCHUWING** Het verhoogde bed of stapelbed niet gebruiken wanneer een onderdeel van de structuur ontbreekt o defect is. De vergangstukken moeten bij de fabrikant of winkel besteld worden.
- e) U moet steeds de montage- en gebruiksrichtlijnen van de fabrikant volgen.
- f) De aandevoelen afmeting van de bij het bed te gebruiken matras is 2000mmx 900mm, Maximale dikte van de matras: 150 mm.
- g) U moet de ruimte goed verluchten om de vochtigheidsgraad te beperken en schimmelvorming in het bed en zijn omgeving te vermijden.
- h) De assemblageonderdelen moeten steeds goed vastgezet zijn en regelmatig gecontroleerd worden. Deze indien nodig aanspannen.
- i) Conform de Europese veiligheidseisen van de norm EN 747+A1:2015.
- j) Een nachtlampje kan het kind in het bovenste bed meer veiligheid bieden.

ESPAÑOL

CONSEJOS PARA EL MONTAJE:

- 1-ESTUDIE ATENTAMENTE EL MANUAL DE MONTAJE.
- 2-LOCALICE LAS PIEZAS QUE CONSTITUYEN SU MUEBLE.
- 3-REUNA Y CONTROLE LOS HERRAJES SUMINISTRADOS.
- 4-EQUIPESE CON LAS HERRAMIENTAS NECESARIAS.
- 5-PREPARE UNA ZONA DE MONTAJE.

CONSEJOS PARA EL MANTENIMIENTO:

- 1-QUITAR EL POLVO CUIDADOSAMENTE.
- 2-HUMEDECER UN PAÑO SUAVE Y LIMPIO CON AGUA LIGERAMENTE ENJABONADA.

NO FUERCE NUNCA EN LAS UNIONES, APRIETE LOS TORNILLOS DESPUES DE CIERTO TIEMPO DE UTILIZACION. CONSERVE SU MANUAL DE MONTAJE, SI FALTARA UNA PIEZA SERIA LA MANERA MAS FACIL DE COMUNICARLO A LA TIENDA.

NO USE NUNCA PRODUCTOS ABRASIVOS TALES COMO: LANA DE ACERO , LIJAS,DISOLVENTES,ETC. NO MOJAR NI SOMETER A GRANDES HUMEDADES AL MUEBLE.

FRANCAIS

INSTRUCTIONS DE MONTAGE:

- 1-LISEZ ATTENTIVEMENT LA NOTICE DE MONTAGE.
- 2-REPEREZ LES PIECES QUI COMPOSENT VOTRE MEUBLE.
- 3-REGROUPEZ ET VERIFIEZ LES FERRURES FOURNIES.
- 4-DOTEZ-VOUS DES OUTILS NECESSAIRES.
- 5-PREPAREZ UN ESPACE DE MONTAGE.

CONSEILS D'ENTRETIEN:

- 1-ENLEVEZ SOIGNEUSEMENT LA POUSSIERE.
- 2-HUMIDIFIEZ UN CHIFFON DOUX ET PROPRE AVEC DE L'EAU LEGEREMENT SAVONNEUSE.

NE FORCEZ JAMAIS LES RACCORDS. RESSERREZ LES VIS APRES UN CERTAIN TEMPS D'UTILISATION. CONSERVEZ LA NOTICE DE MONTAGE. EN CAS DE PIECE MANQUANTE , CE SERA LE MEILLEUR MOYEN D'EN INFORMER LE MAGASIN.

N'UTILISEZ JAMAIS DES PRODUITS ABRASIFS COMME DE LA LAINE D'ACIER, DU PAPIER DE VERRE, DES SOLVANTS, ETC. NE MOUILLEZ PAS LE MEUBLE ET EVITEZ TOUTE ESPOSITION A UNE HUMIDITE IMPORTANTE.

DEUTSCH

HINWEISE ZUR MONTAGE:

- 1- LESEN SIE AUFMERKSAM DIE MONTAGEANLEITUNG DURCH.
- 2- LOKALISIEREN SIE DIE ZUM MÖBEL GEHÖRENDE TEILE.
- 3- KONTROLLIEREN SIE DIE MITGELIEFERTEN WERKZEUGE.
- 4- RÜSTEN SIE SICH MIT DEN ZUSÄTZLICH BENÖTIGTEN WERKZEUGEN AUS.
- 5- BEREITEN SIE EINEN PLATZ FÜR DIE MONTAGE VOR.

HINWEISE ZUR PFLEGE:

- 1- ENTFERNEN SIE UMSICHTIG DEN ANGESAMMELTEN STAUB.
- 2- VERWENDEN SIE EIN WEICHES UND SAUBERES TUCH UND SCHWACHE SEIFENLAUGE.

FORCIEREN SIE NIEMALS DIE VERBINDUNGEN. ZIEHEN SIE DIE SCHRAUBEN NACH EINER BESTIMMTEN NUTZUNGSZEIT NACH. BEWAHREN SIE DIE MONTAGEANLEITUNG AUF. SOLLTE EIN TEIL FEHLEN IST SIE VON GROSSER WICHTIGKEIT BEI DER NACHBESTELLUNG IM LADEN.

VERWENDEN SIE NIEMALS SCHEUERENDE PRODUKTE WIE STAHLWOLLE, SCHMIRGELPAPIER, LÖSUNGSMITTEL UND DERGL. WASSER UND HOHE FEUCHTIGKEIT SIND SCHÄDLICH FÜR DAS MÖBEL.

ITALIANO

CONSIGLI PER IL MONTAGGIO:

- 1- STUDIARE ATTENTAMENTE IL MANUALE DI MONTAGGIO.
- 2- INDIVIDUARE LE PARTI CHE COSTITUISCONO IL MOBILE.
- 3- RACCOGLIERE E CONTROLLARE GLI ATTREZZI IN DOTAZIONE.
- 4- PROCURARSI GLI ATTREZZI NECESSARI.
- 5- PREPARARE UNA ZONA PER IL MONTAGGIO.

CONSIGLI PER LA MANUTENZIONE:

- 1- SPOLVERARE ACCURATAMENTE.
- 2- INUMIDIRE UN PANNO MORBIDO E PULITO CON ACQUA E POCO DETERGENTE.

NON FORZARE MAI LE GIUNTURE. STRINGERE NUOVAMENTE LE VITI DOPO UN CERTO PERIODO D'USO. CONSERVARE IL MANUALE DI MONTAGGIO: SE MANCASSE UN PEZZO SAREBBE COSÌ PIÙ FACILE COMUNICARLO AL RIVENDITORE.

NON USARE MAI PRODOTTI ABRASIVI COME: SPUGNE ABRASIVE, CARTA VETRATA, SOLVENTI, ECC. NON BAGNARE NE' SOTTOPORRE IL MOBILE A FORTE UMIDITÀ.

POTUGUES

CONSELHO PARA A MONTAGEM :

- 1 - ESTUDE ATENTAMENTE O MANUAL DE MONTAGEM.
- 2 - LOCALIZE AS PEÇAS QUE CONSTITUEM O SEU MÓVEL.
- 3 - REUNA E CONTROLE AS FERRAGENS FORNECIDAS.
- 4 - EQUIPE-SE COM AS FERRAMENTAS NECESSÁRIAS.
- 5 - PREPARE UMA ZONA DE MONTAGEM.

CONSELHOS PARA A MANUTENÇÃO :

- 1- RETIRAR A POEIRA COM CUIDADO.
- 2- HUMEDECER UM PANO SUAVE E LIMPO COM ÁGUA LIGEIRAMENTE ENSABOADA.

NUNCA FORCE AS UNIÕES. APORTE OS PARAFUSOS DEPOIS DE DETERMINADO TEMPO DE UTILIZAÇÃO.. CONSERVE O SEU MANUAL DE MONTAGEM, SE FALTAR UMA PEÇA SERIA A MANEIRA MAIS FÁCIL DE A COMUNICAR À LOJA.

NUNCA USE PRODUTOS ABRASIVOS TAIS COMO : LÃ DE AÇO, LIXAS, DISSOLVENTES, ETC.. NÃO MOLAR NEM SUBMETER A GRANDES HUMIDADES, O MÓVEL.

POLSKU

WSKAZÓWKI ODNOŚNIE MONTAŻU:

1. PRZECZYTAĆ UWAGNIE NINIEJSZE ZALECENIA.
2. ZLOKALIZOWAĆ CZĘŚCI SKŁADOWE MEBLA.
3. ZEBRAC WSZYSTKIE ELEMENTY ŁACZĄCE.
4. ZAOPATRZYĆ SIĘ W NIEZBEDNE NARZĘDZIA.
5. PRZYGOTOWAĆ ODPOWIEDNIE MIEJSCA NA MONTAŻ.

WSKAZÓWKI ODNOŚNIE KONSERWACJI:

1. ODKURZAC OSTROŻNIE.
2. W TYM CELU ZWILŻYC CZYSTĄ MIEKKĄ SZMATKĘ W SŁABYM ROZTWORZE WODY Z MYDŁEM.

NIE DOCISKAC NA SILE ELEMENTÓW ŁACZĄCYCH. DOKRECIC SRUBY PO UPLYWIE PEWNEGO CZASU. ZACHOWAĆ INSTRUKCJE MONTAŻOWE; W RAZIE BRAKU JAKIEJS CZĘŚCI, ULATWIA ONE KONTAKT ZE SPRZEDAWCĄ.

NIE NALEŻY NIGDY UŻYWAĆ ŚRODKÓW SZORUJĄCYCH, TAKICH JAK WELNA STAŁOWA, PAPIER SCIERNY, ROZPUSZCZALNIKI ITP. NIE MOCZYĆ ANI NIE PODDAWAĆ MEBLA DZIAŁANIU DUŻEJ WILGOTNOŚCI.

ENGLISH

ASSEMBLY ADVICE:

- 1- STUDY THE ASSEMBLY MANUAL CAREFULLY.
- 2- LOCATE THE PARTS THAT COMPRISE YOUR FURNITURE ITEM.
- 3- ORGANISE AND CHECK THE FITTINGS SUPPLIED.
- 4- HAVE THE NECESSARY TOOLS TO HAND.
- 5- PREPARE AN ASSEMBLY AREA.

MAINTENANCE ADVICE:

- 1- REMOVE DUST CAREFULLY.
- 2- MOISTEN A SOFT, CLEAN CLOTH WITH SLIGHTLY SOAPY WATER.

DO NOT FORCE ANY OF THE JOINTS. TIGHTEN THE SCREWS AFTER HAVING USED THE FURNITURE FOR SOME TIME. KEEP YOUR ASSEMBLY MANUAL. IF ANY PART IS MISSING, IT WILL HELP YOU TO LET THE SHOP KNOW.

NEVER USE ABRASIVE PRODUCTS SUCH AS STEEL WOOL, SANDPAPER, ETC. DO NOT WET THE FURNITURE OR KEEP IT IN A VERY DAMP PLACE.

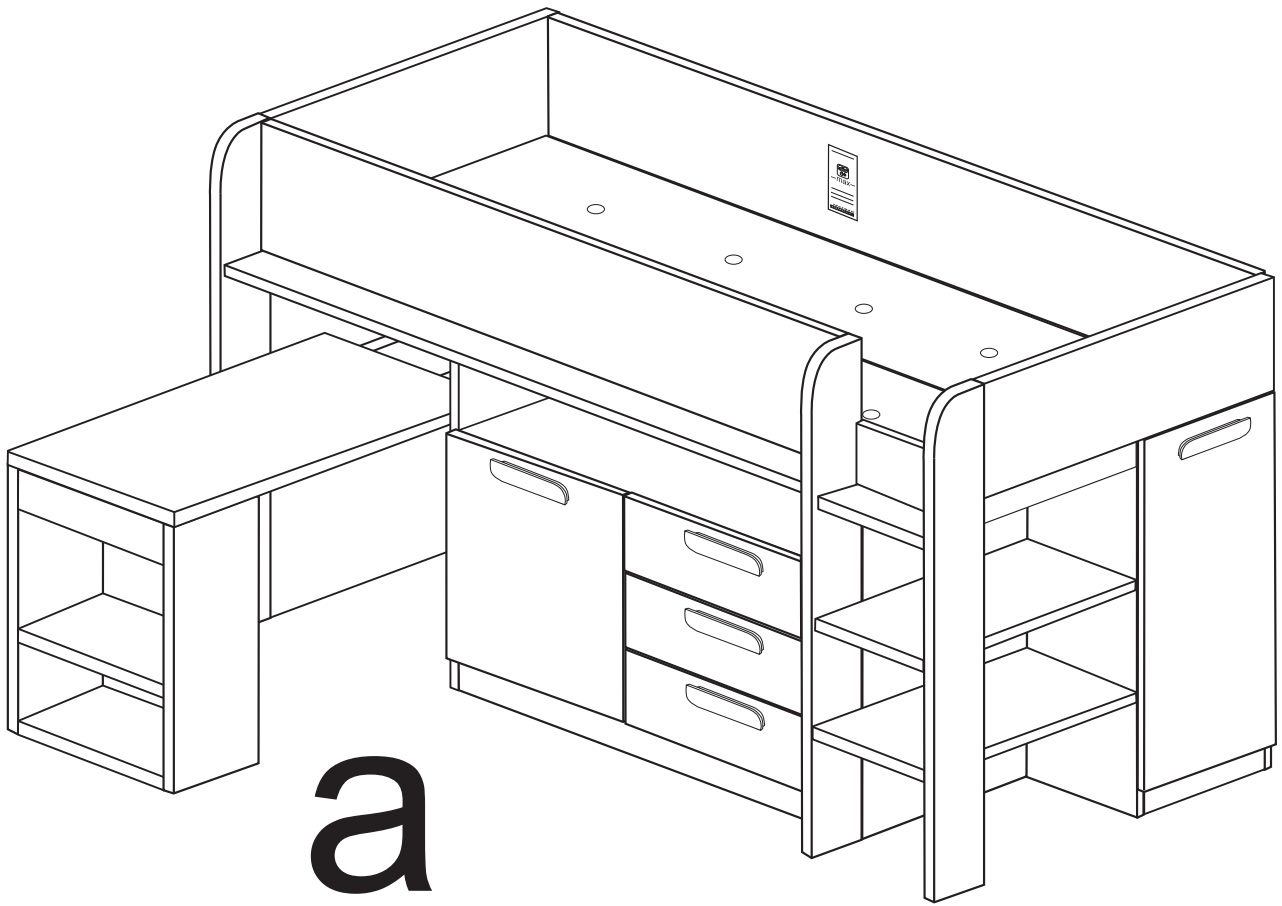

a

?

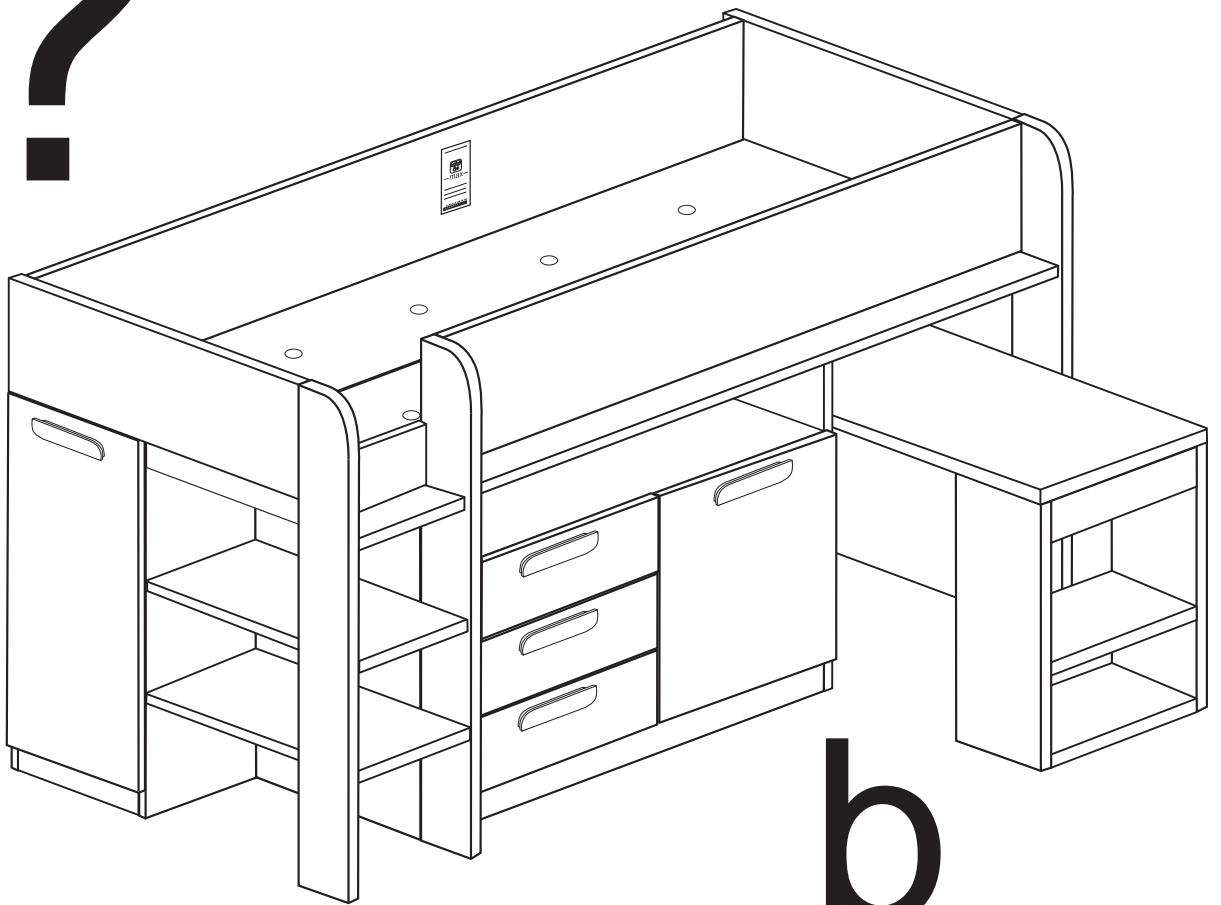

b

1a

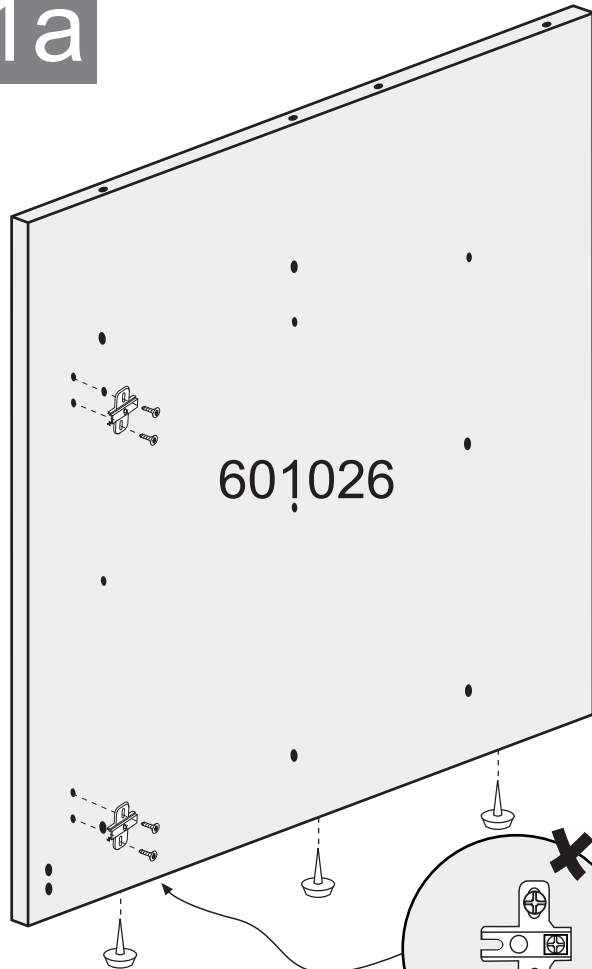

601026

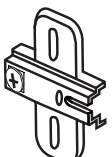
x2

 BA35S

x3

 TSM

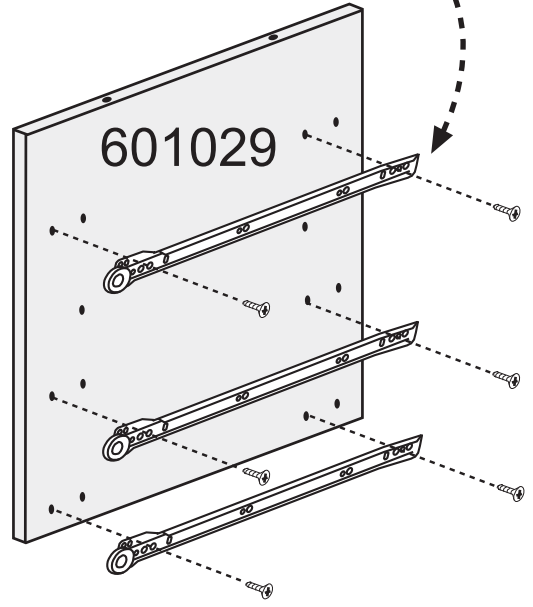
GR45G  x3



601029

NO OK

cm 0 1 2 3

TV3135  x10

2a

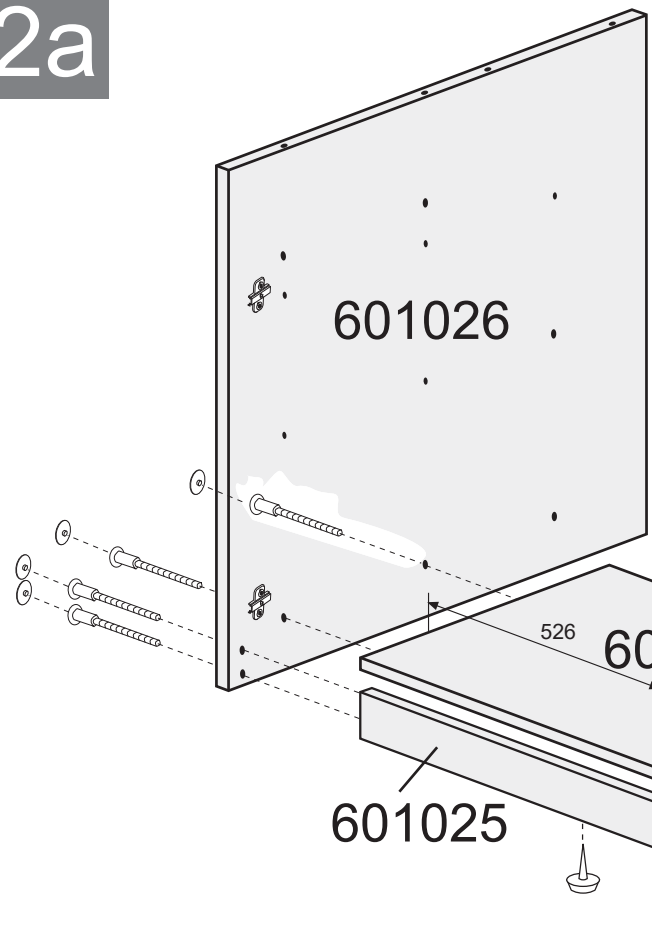

601026

601028

601025

526

553

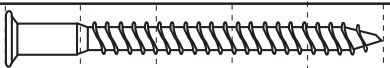
cm 0 1 2 3 4 5
 TA550  x4

x1

 TSM

x4

 TA3BL

3a

cm 0 1 2 3 4 5

TA550  x4

CL830  x2

x2



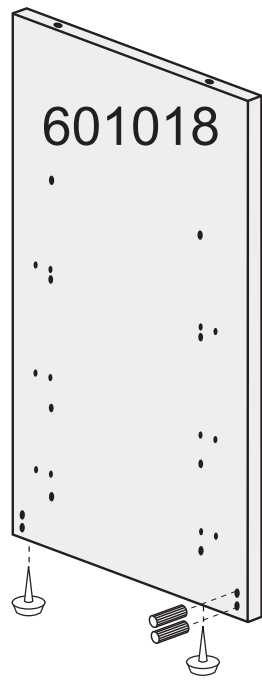
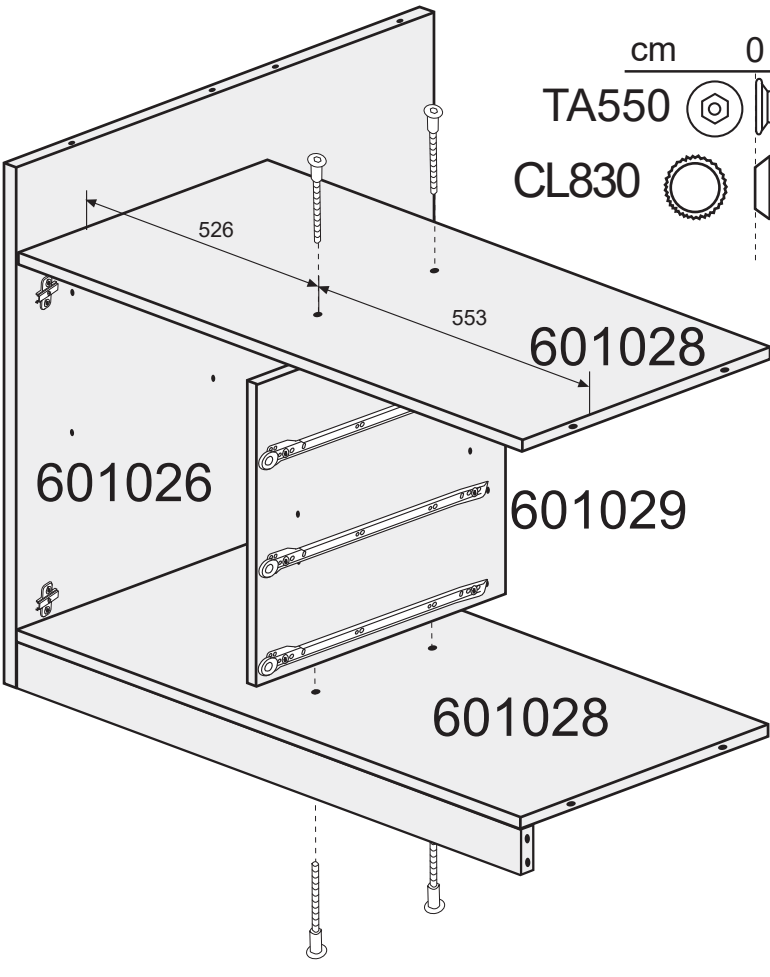

TSM



4a

cm 0 1 2 3 4 5 6

TA760  x4

TA550  x2

x4

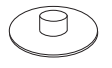

TA3BL

x1

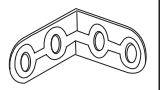

EA3030

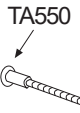
TA550 

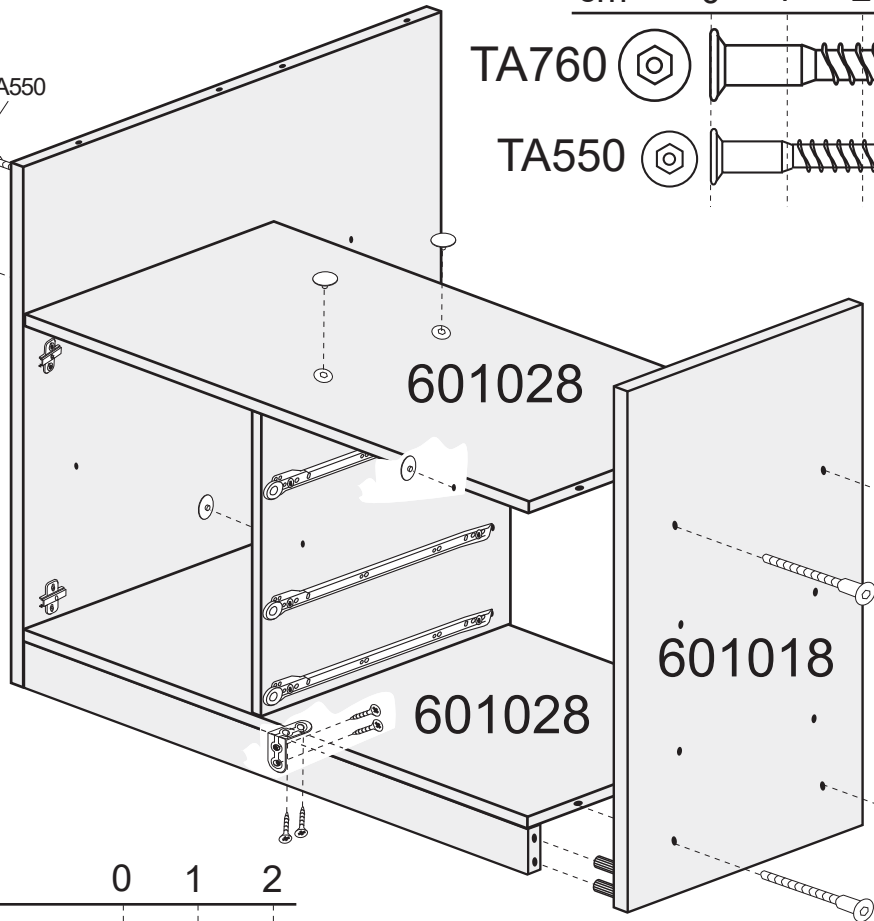

TP3515  x4

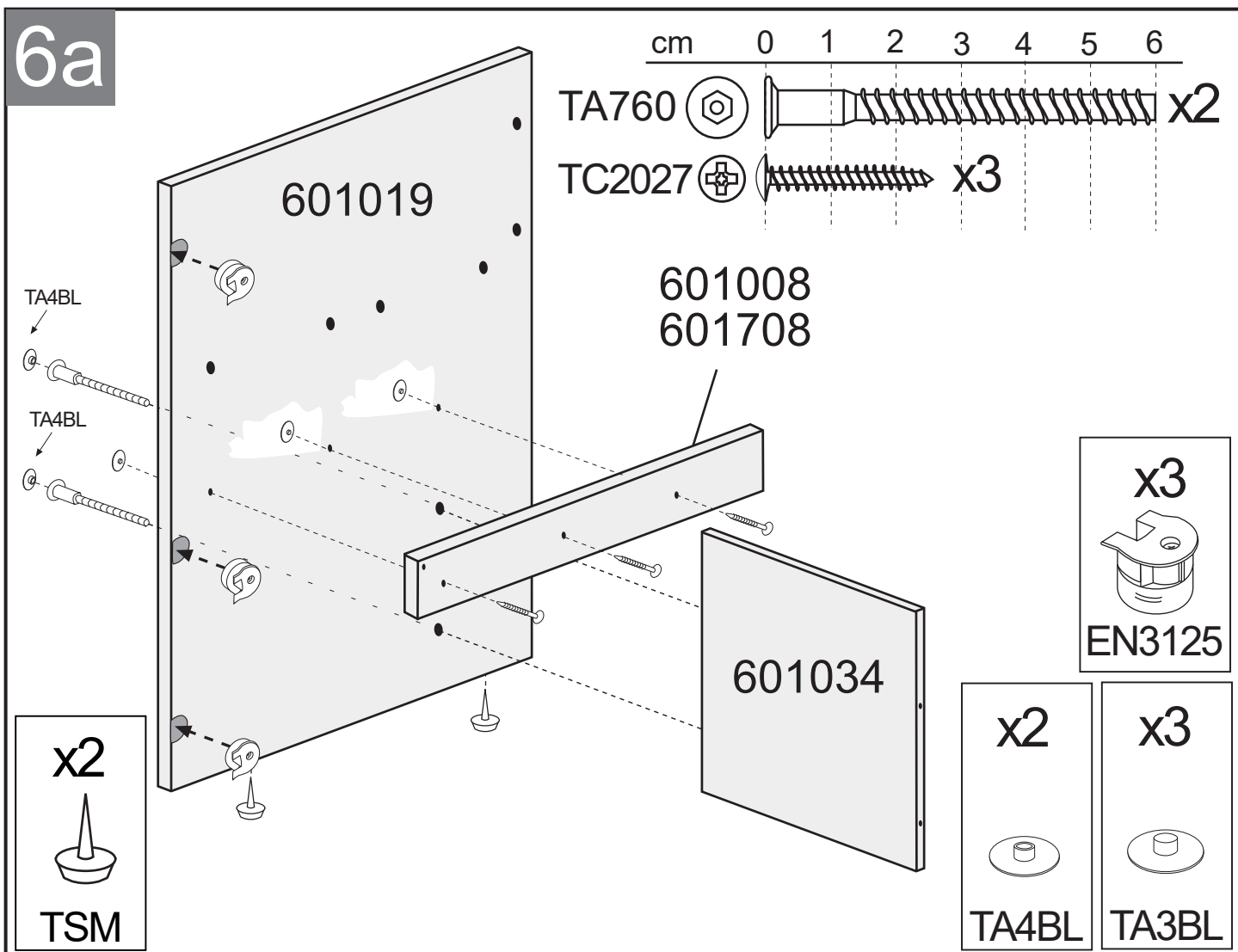
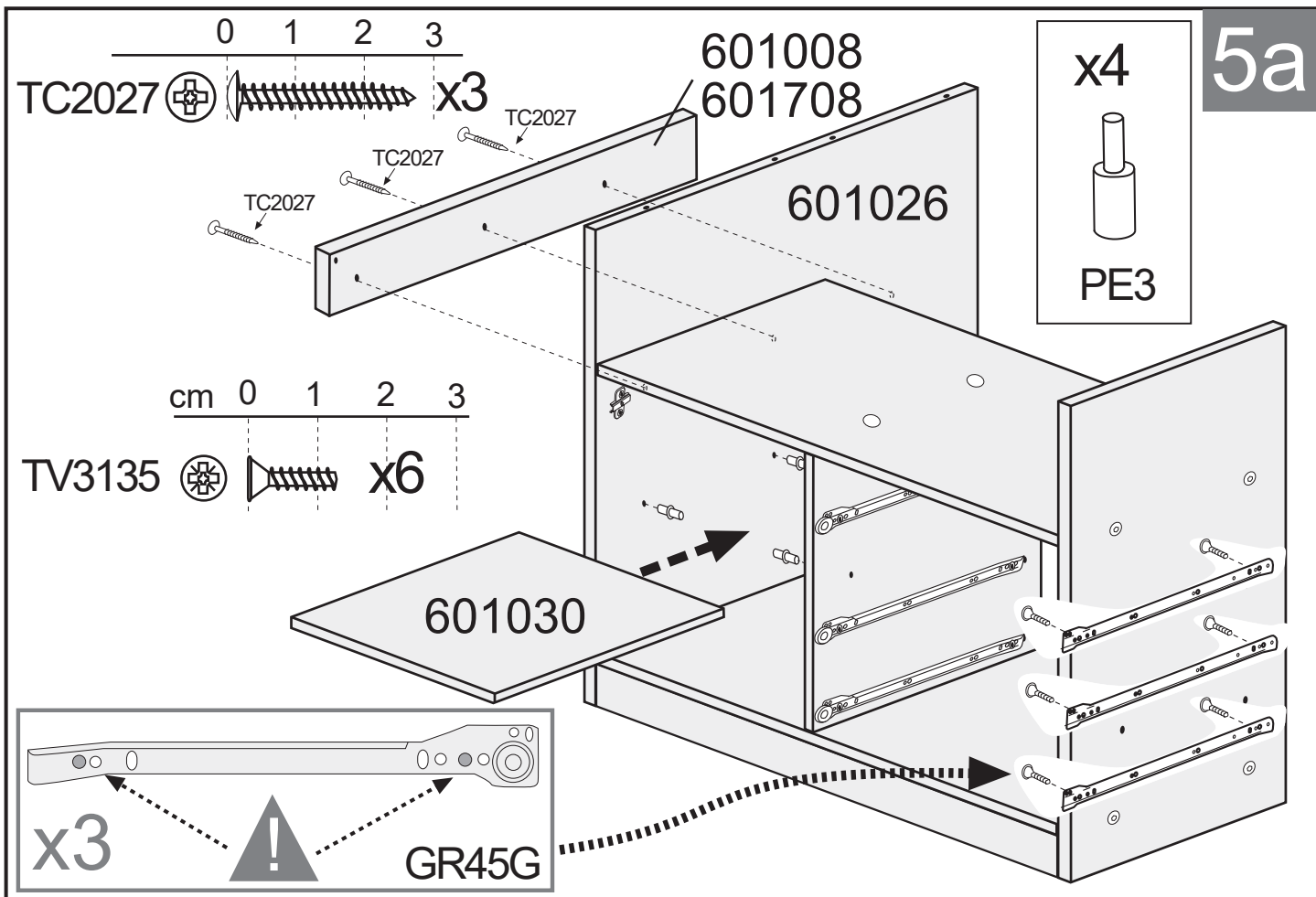

7a

cm 0 1 2 3 4 5
TA550  x2

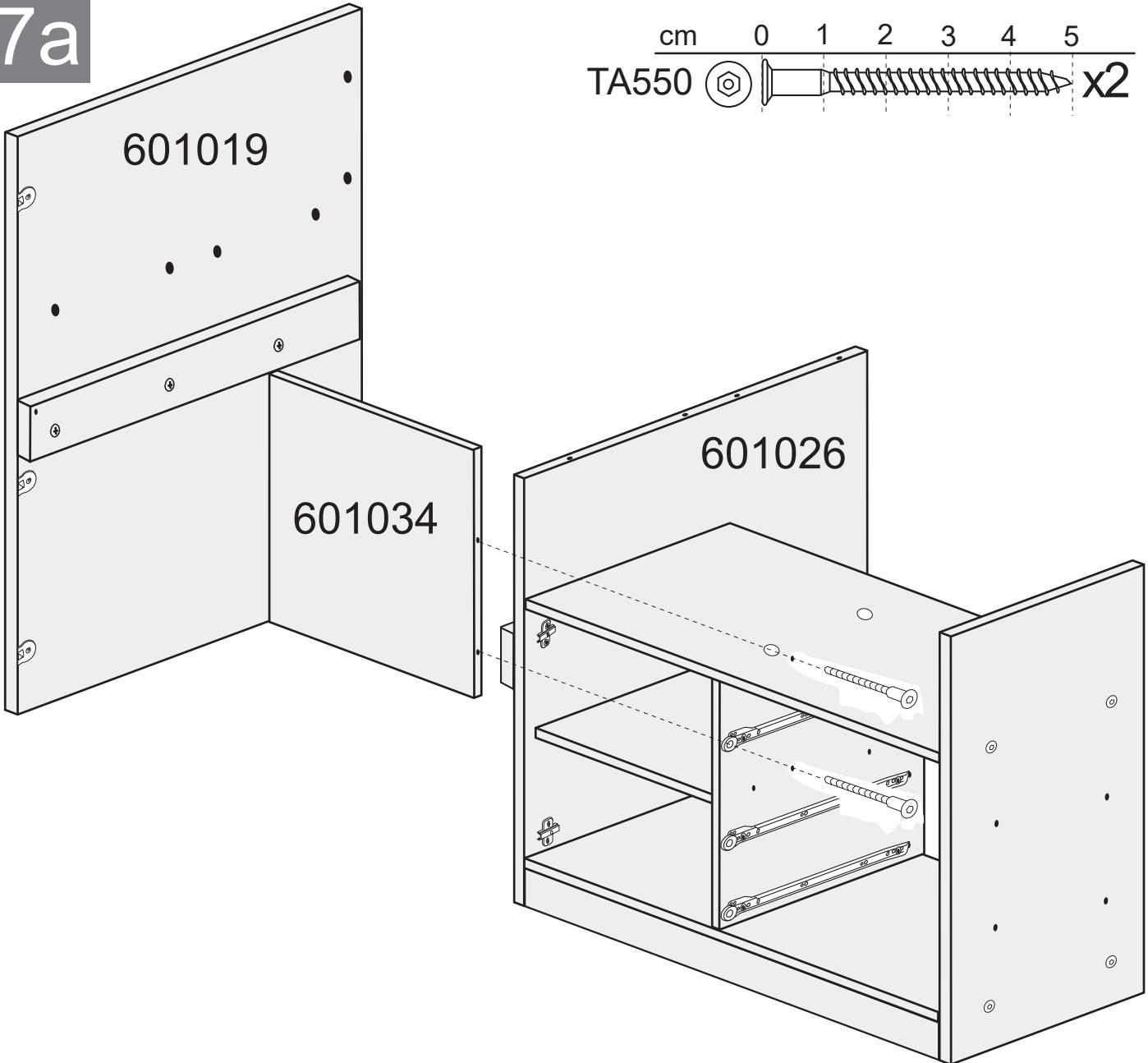

8a

x6

SKM16

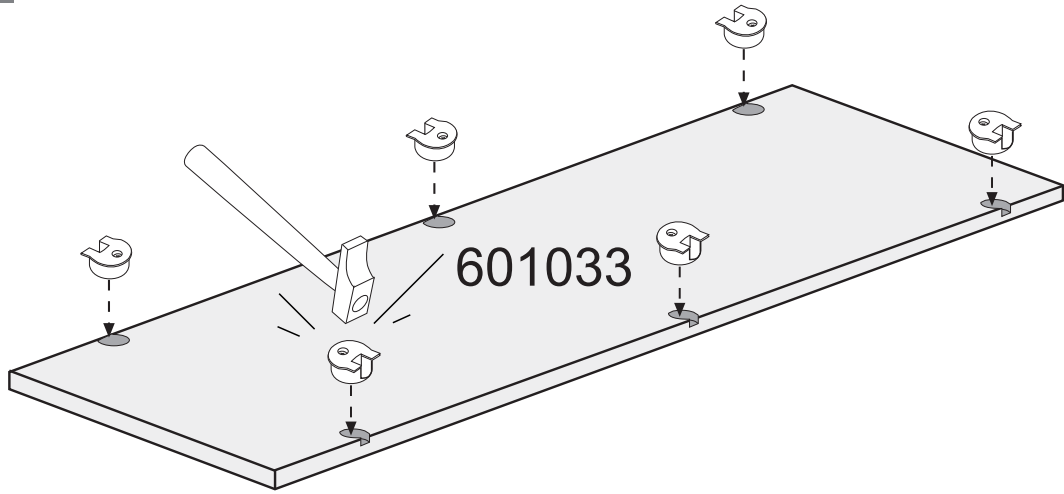

9a

cm 0 1 2 3

TCK0311  x6

TV3135  x4

x4

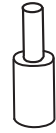

PE3

x4



TSM

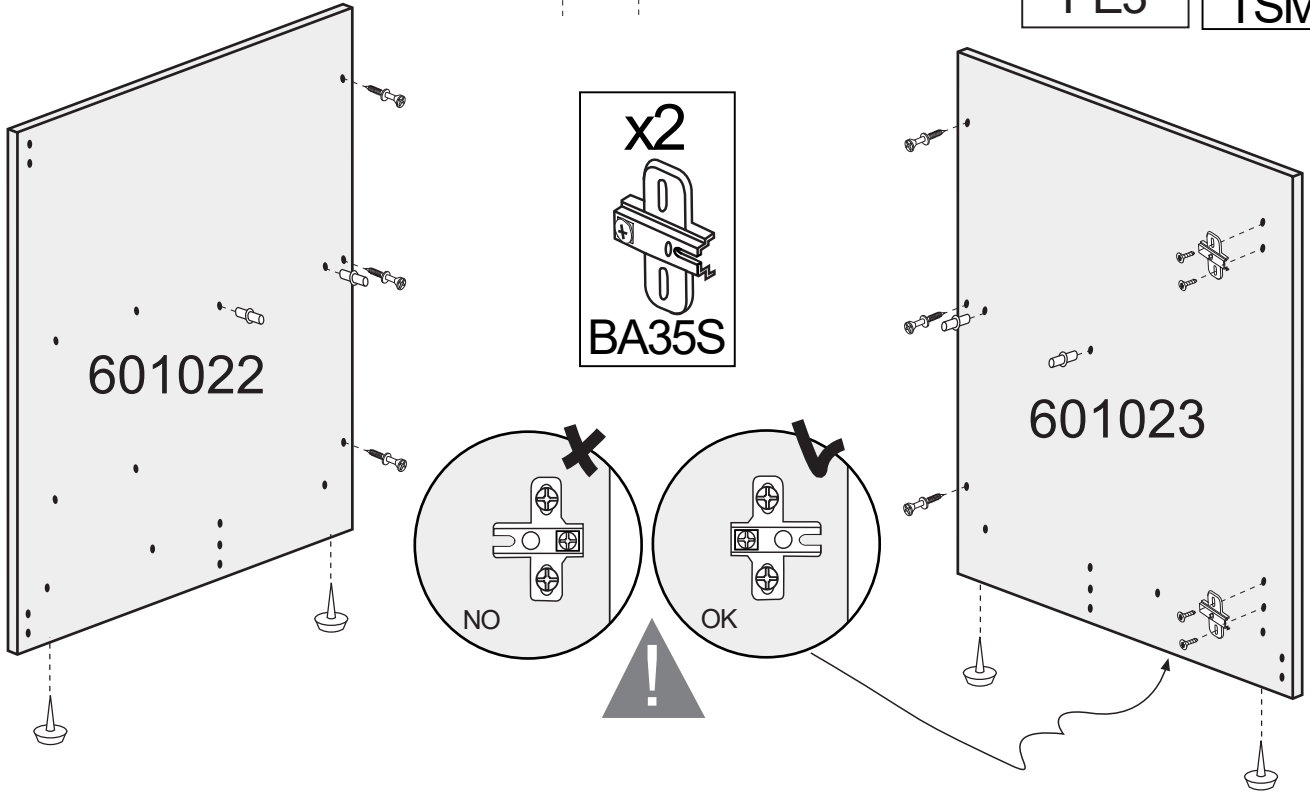

10a

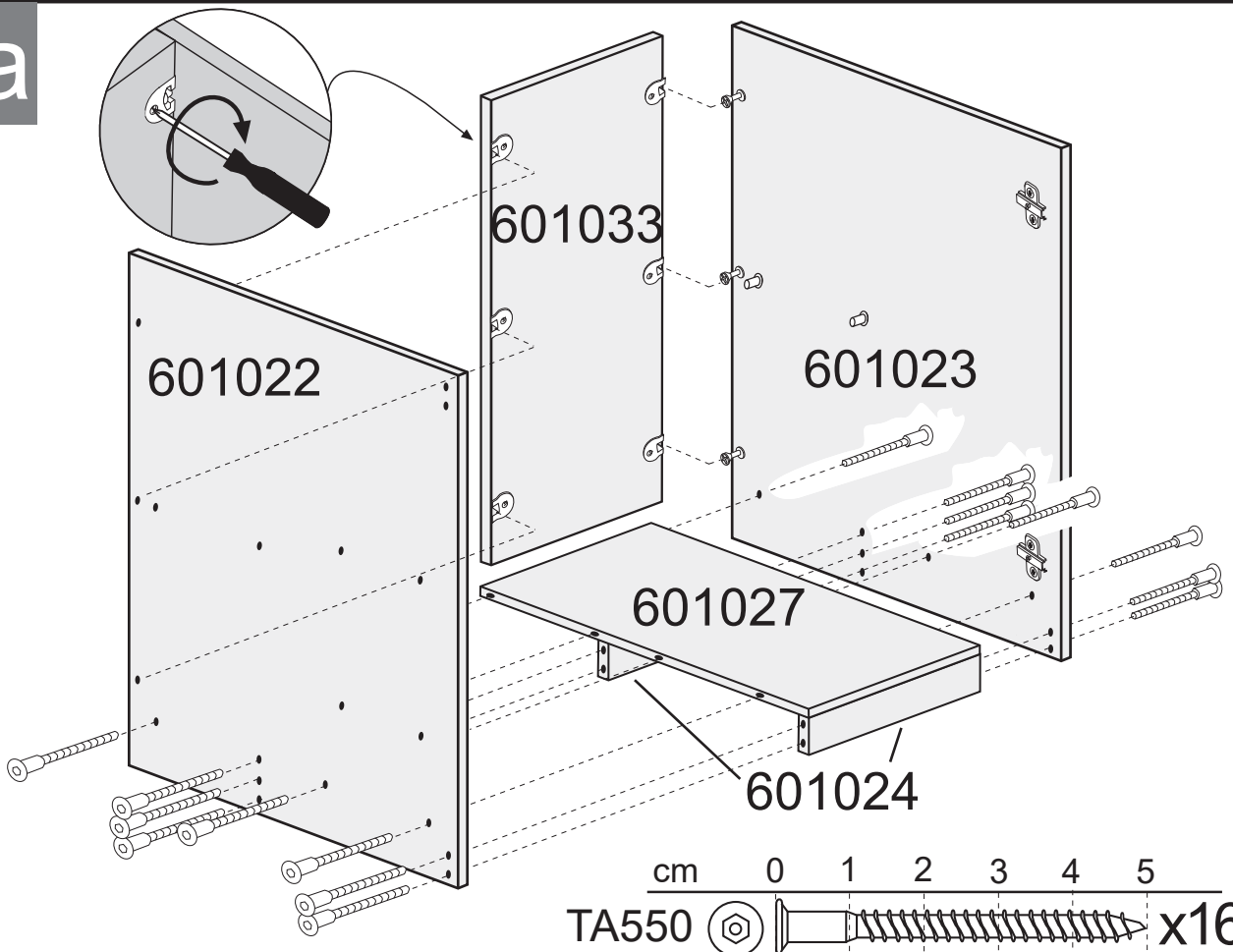

11a

cm 0 1 2 3 4

TP3540   x4

TEN513   x3

x4

TSM

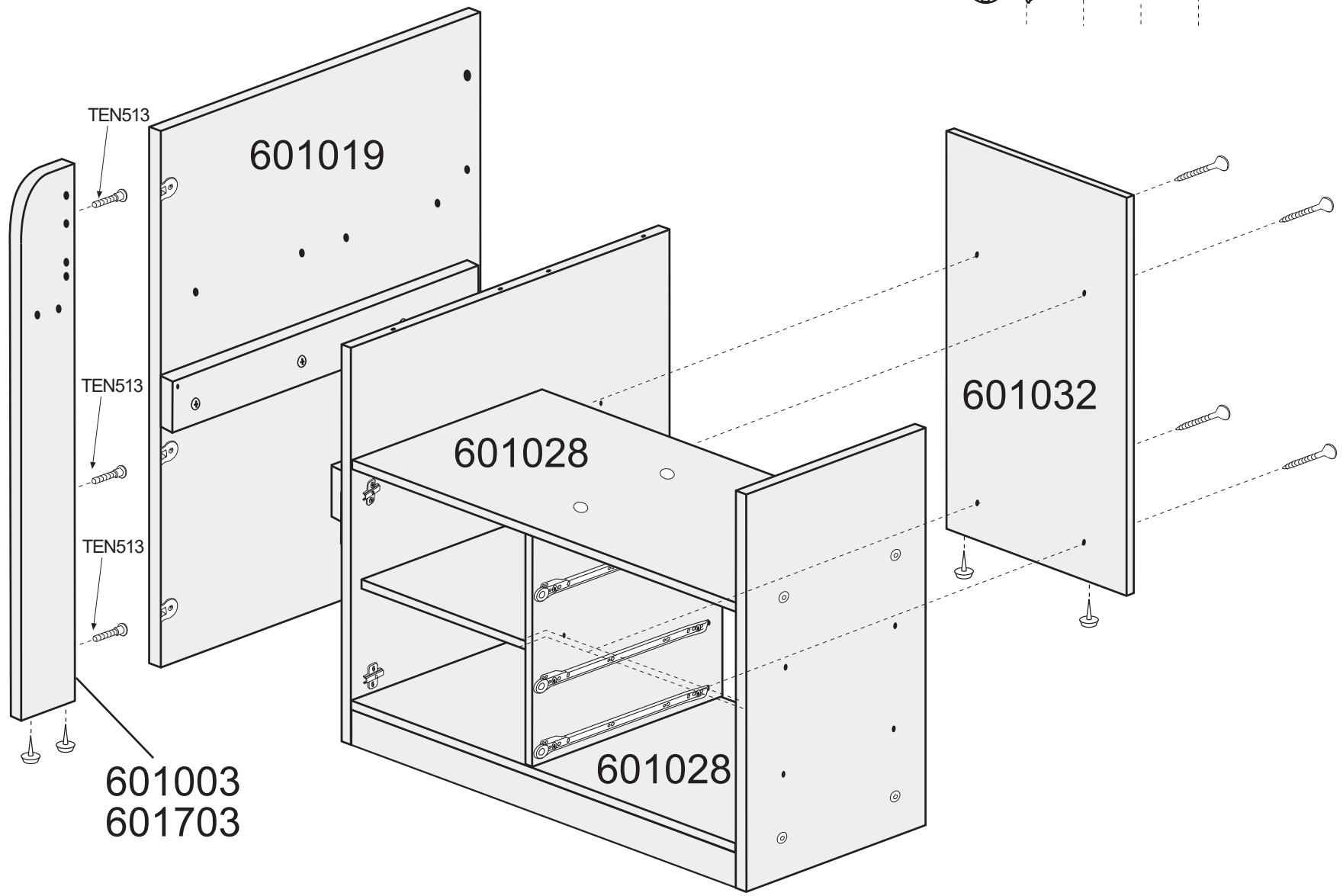

12a

BA433

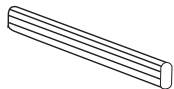

x1

x4



TA4BL

x2



SBO22P

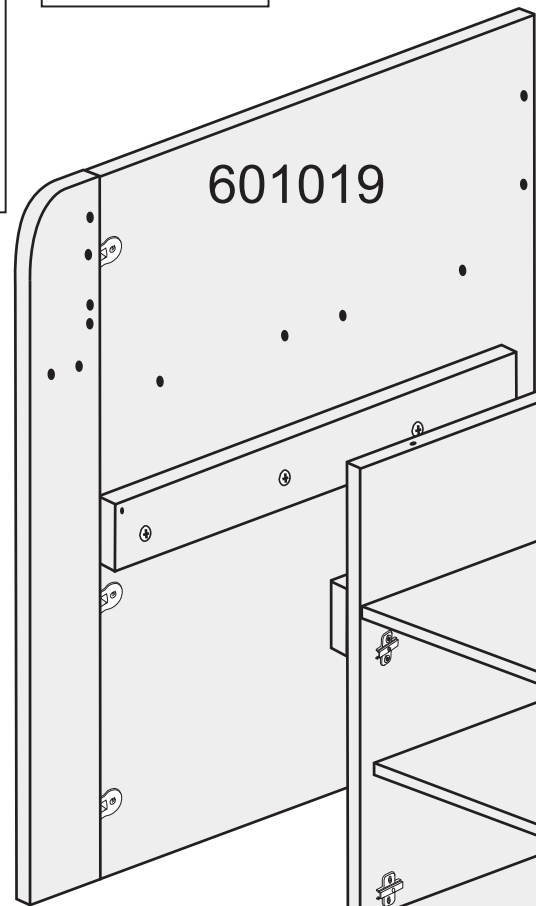

601019

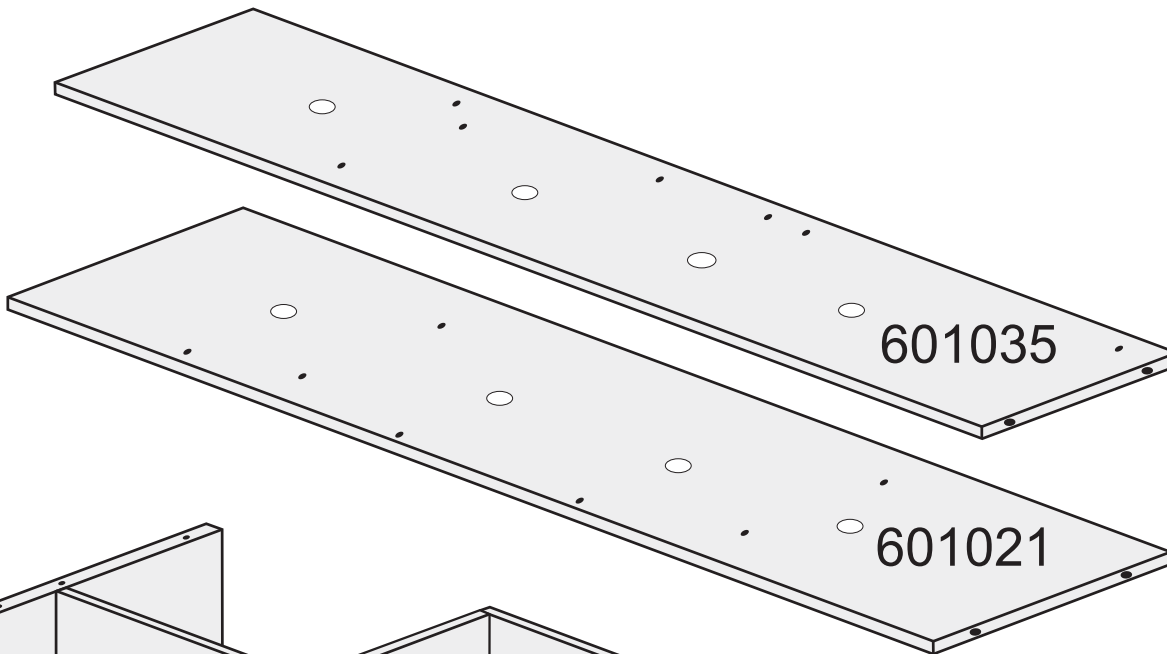

601035

601021

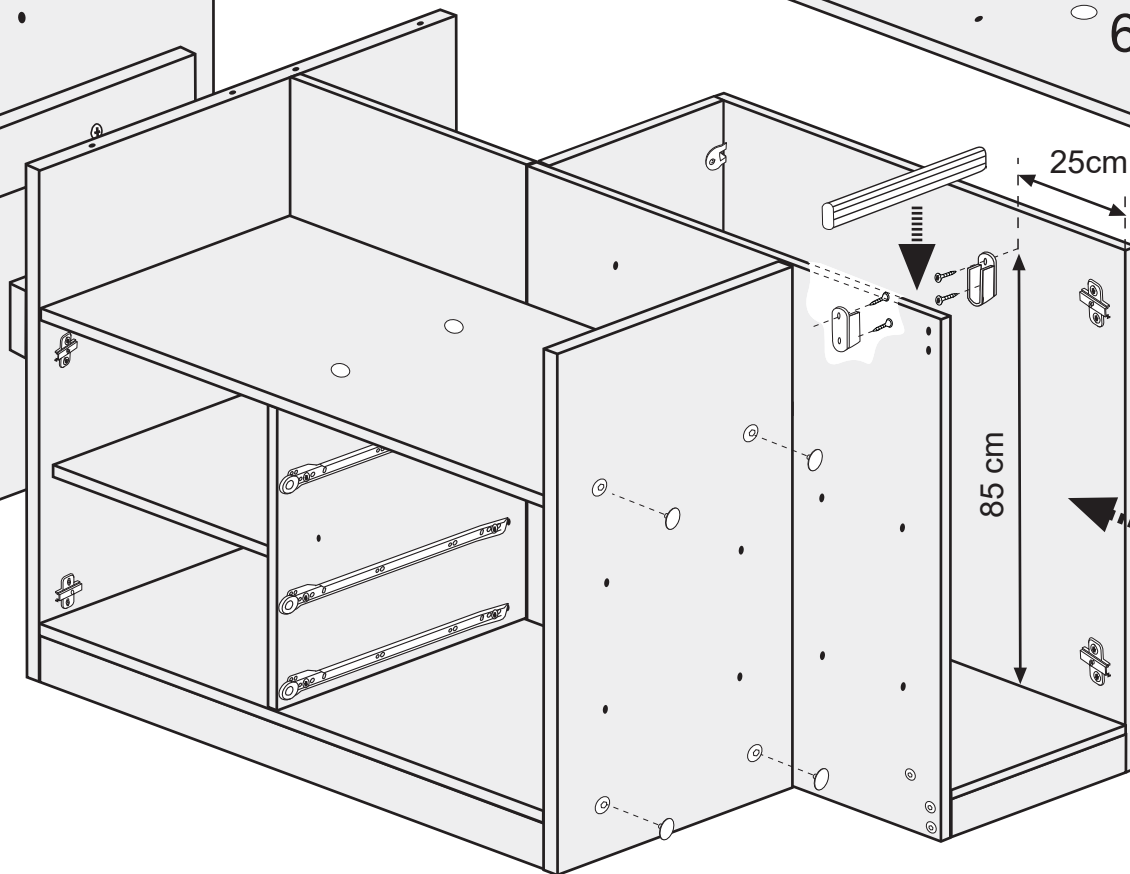

25cm

85 cm

601036

cm 0 1 2

TP3515  x4

13a

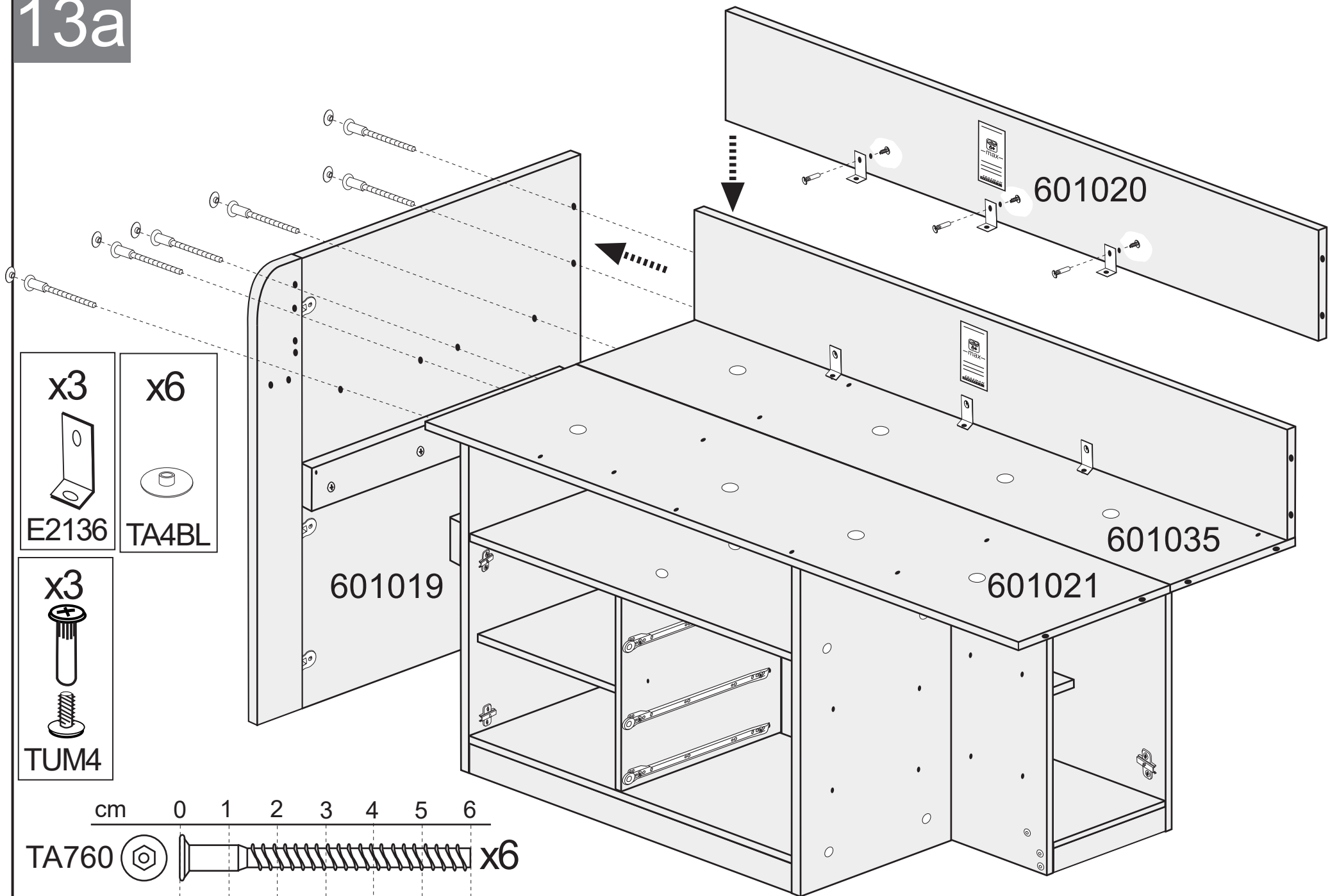

x3



E2136

x6



TA4BL

x3



TUM4

cm 0 1 2 3 4 5 6

TA760  x6

14a

- 601015 Azul/Bleu/Blue
- 601115 Verde/Vert/Green
- 601215 Fucsia/Fuchsia
- 601315 Grafito/Graphite
- 601415 Tornasol/Tournesol/Sunflower
- 601515 Rojo/Rouge/Red
- 601615 Molina
- 601715 Cascina
- 601815 Azul ahumado / Smokey Blue / Bleu fumé
- 601915 Rose Antique / Antique Pink

x3



TUM4

x4



TA3BL

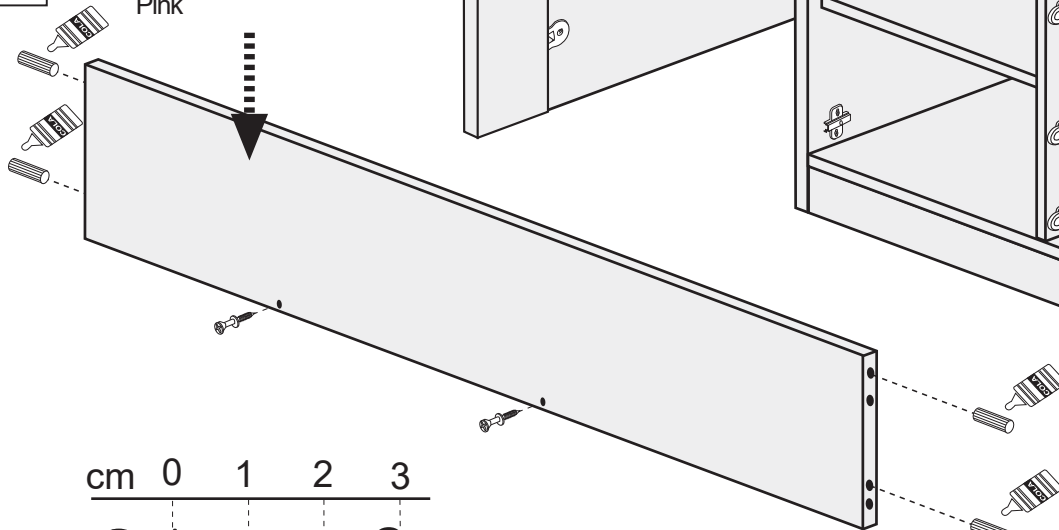
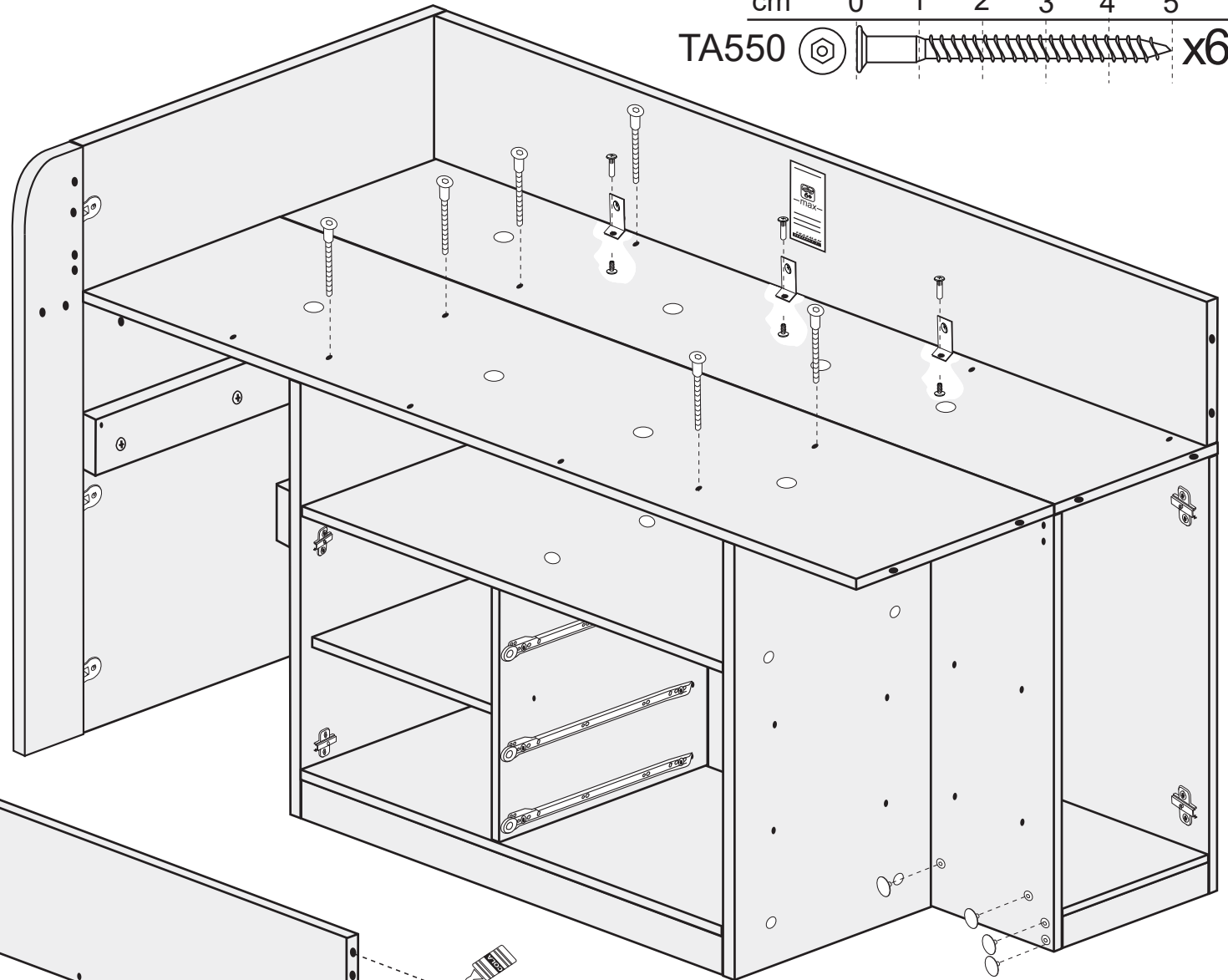
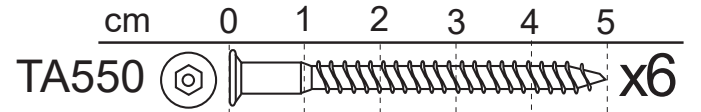

TCK0311  x2

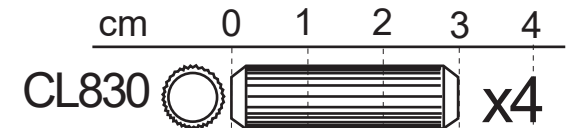

601015 / 601115 / 601215
601315 / 601415 / 601515
601615 / 601715 / 601815
601915

cm 0 1 2 3

TV5135   x3

x2



SKM16

x3



E2136

x3



TUM4

x2



T8AL
T8PC

x2



TA4AL
TA4PC

15a

601006
601706

cm 0 1 2 3 4 5 6

TA760   x2

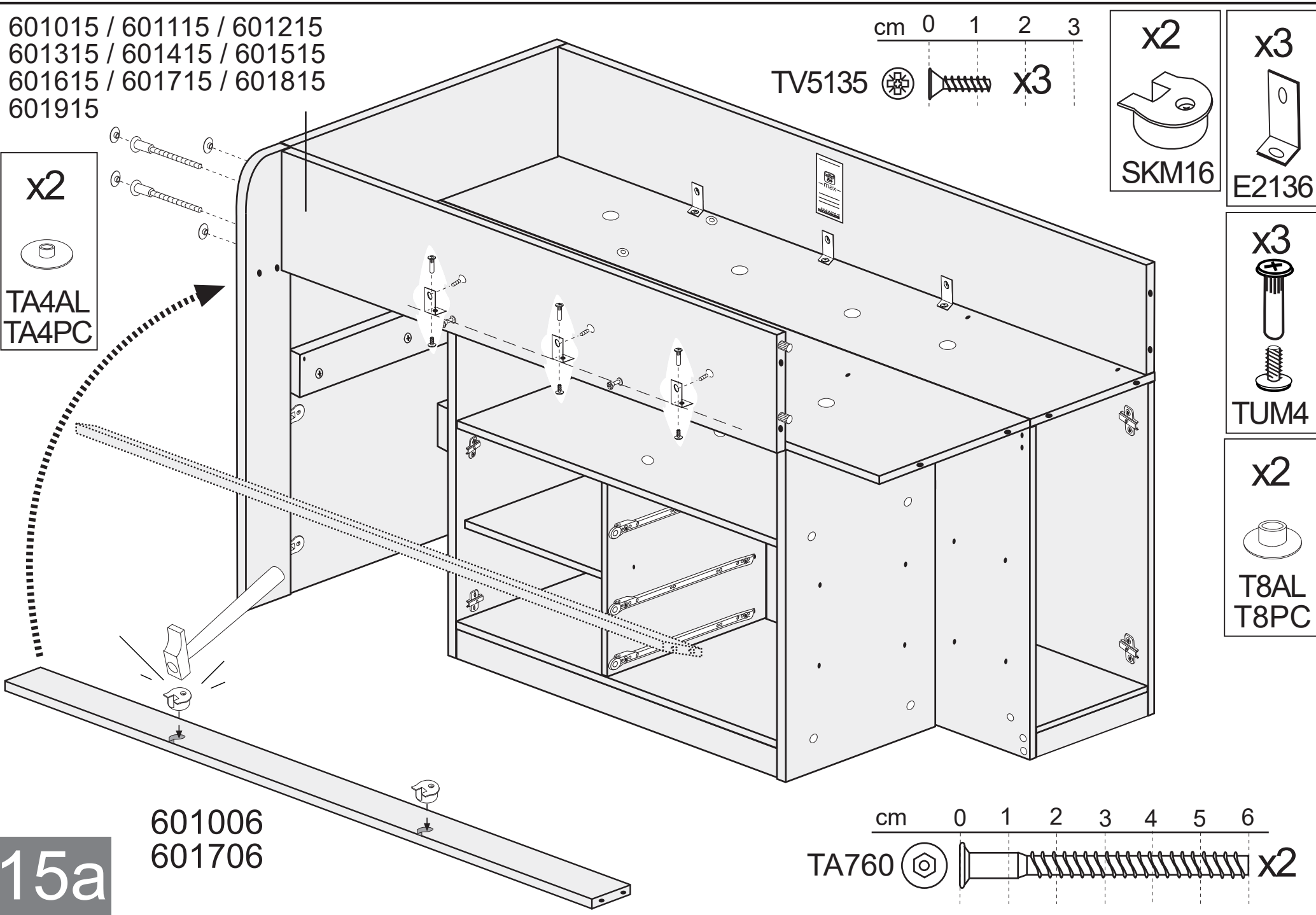

16a

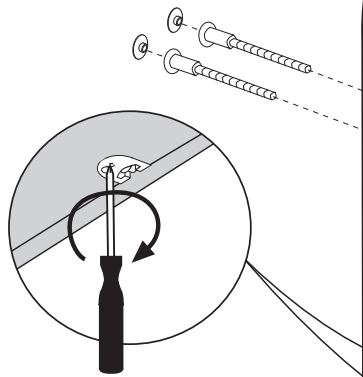

x2



TA4AL
TA4PC

x2



CT8B

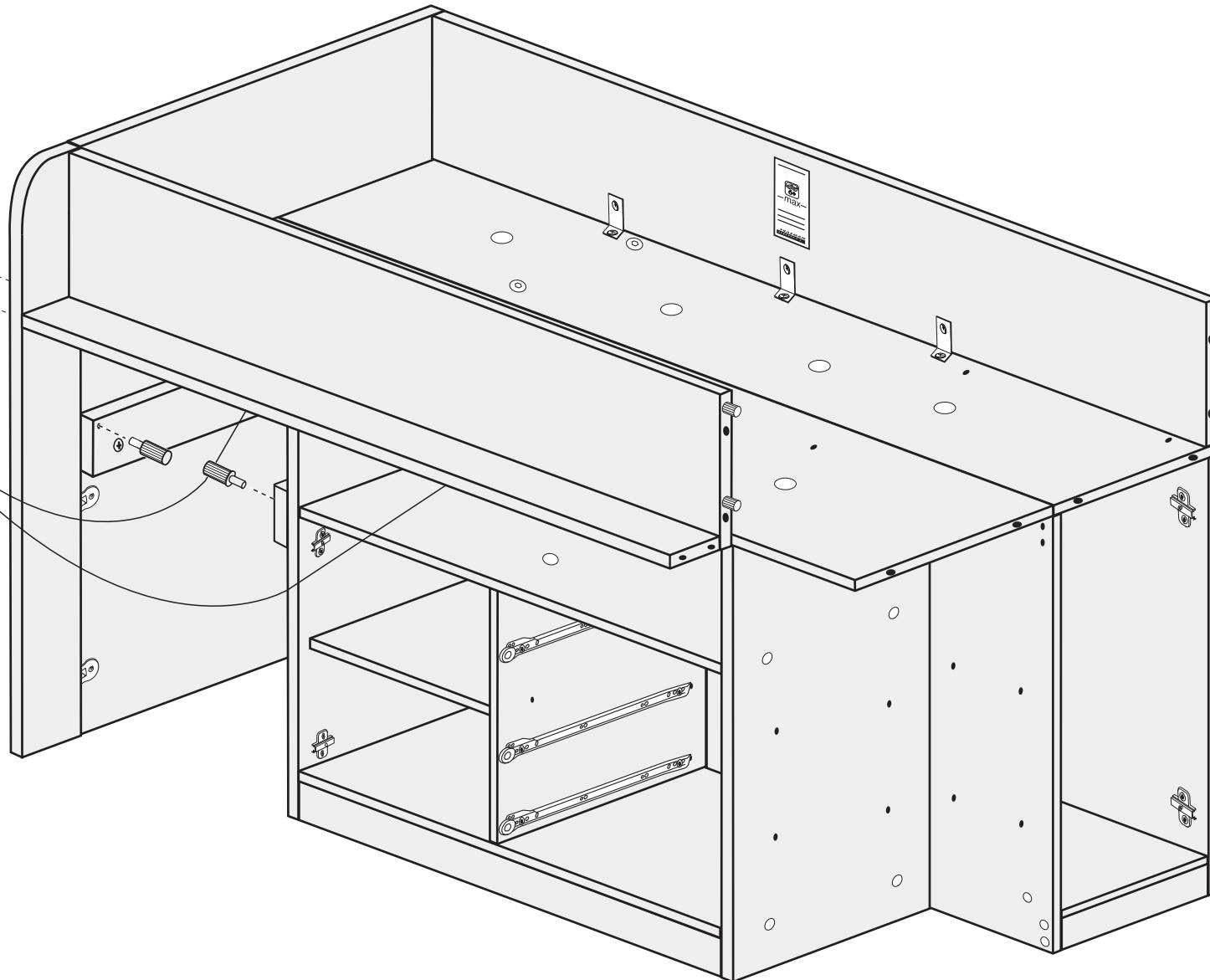

cm 0 1 2 3 4 5 6

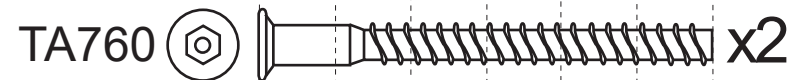



TA760 x2

17a

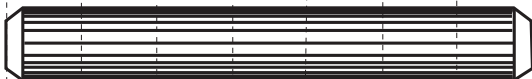
cm 0 1 2 3 4 5 6 7

CL1070   x12

CL830   x4

x2

T5AL
T5PC

x4

TSM

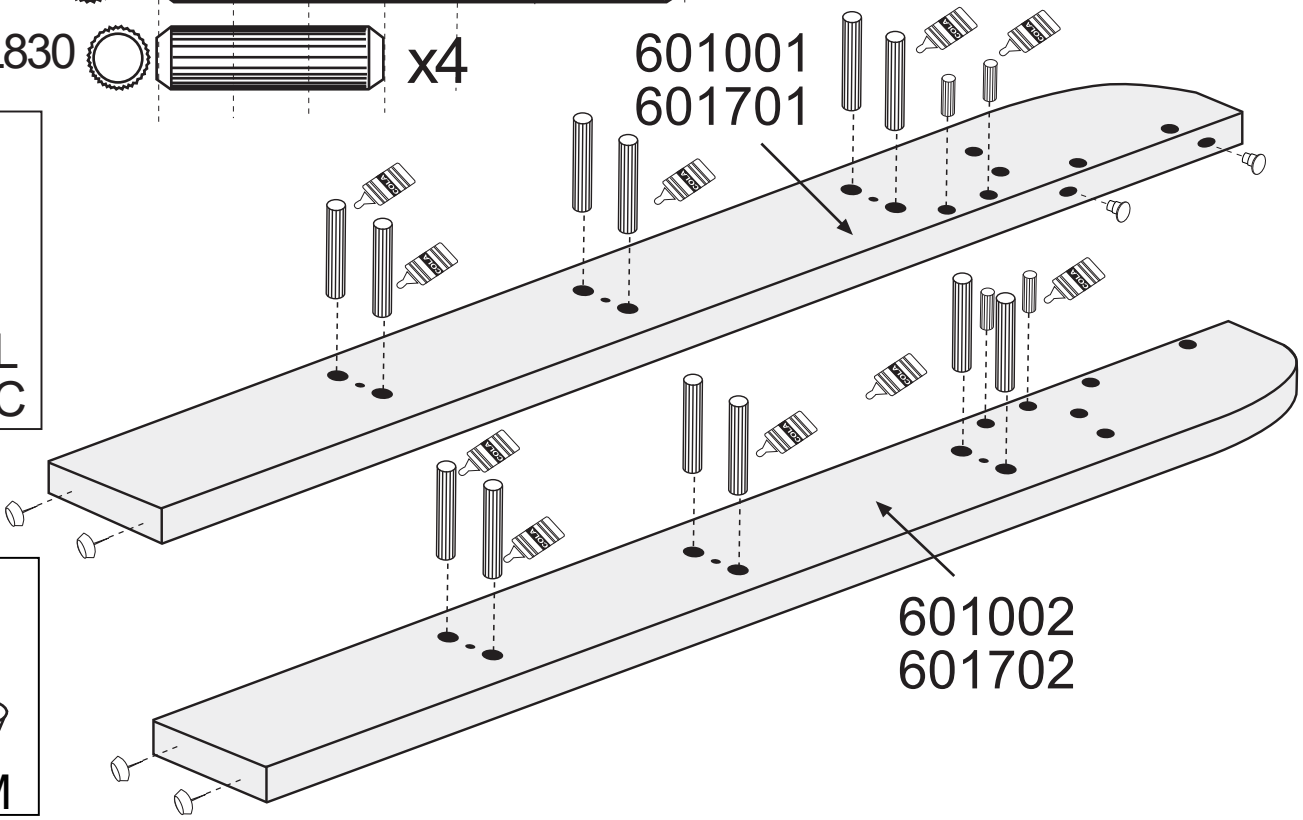
601001
601701

601002
601702

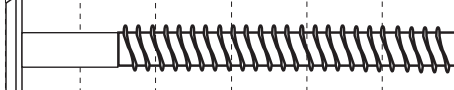

cm 0 1 2 3 4 5 6

TM660A   x3

TUEM61013   x3

x4

SKM16

601001
601701

601011
601711

601004
601704

601005
601705

601005
601705

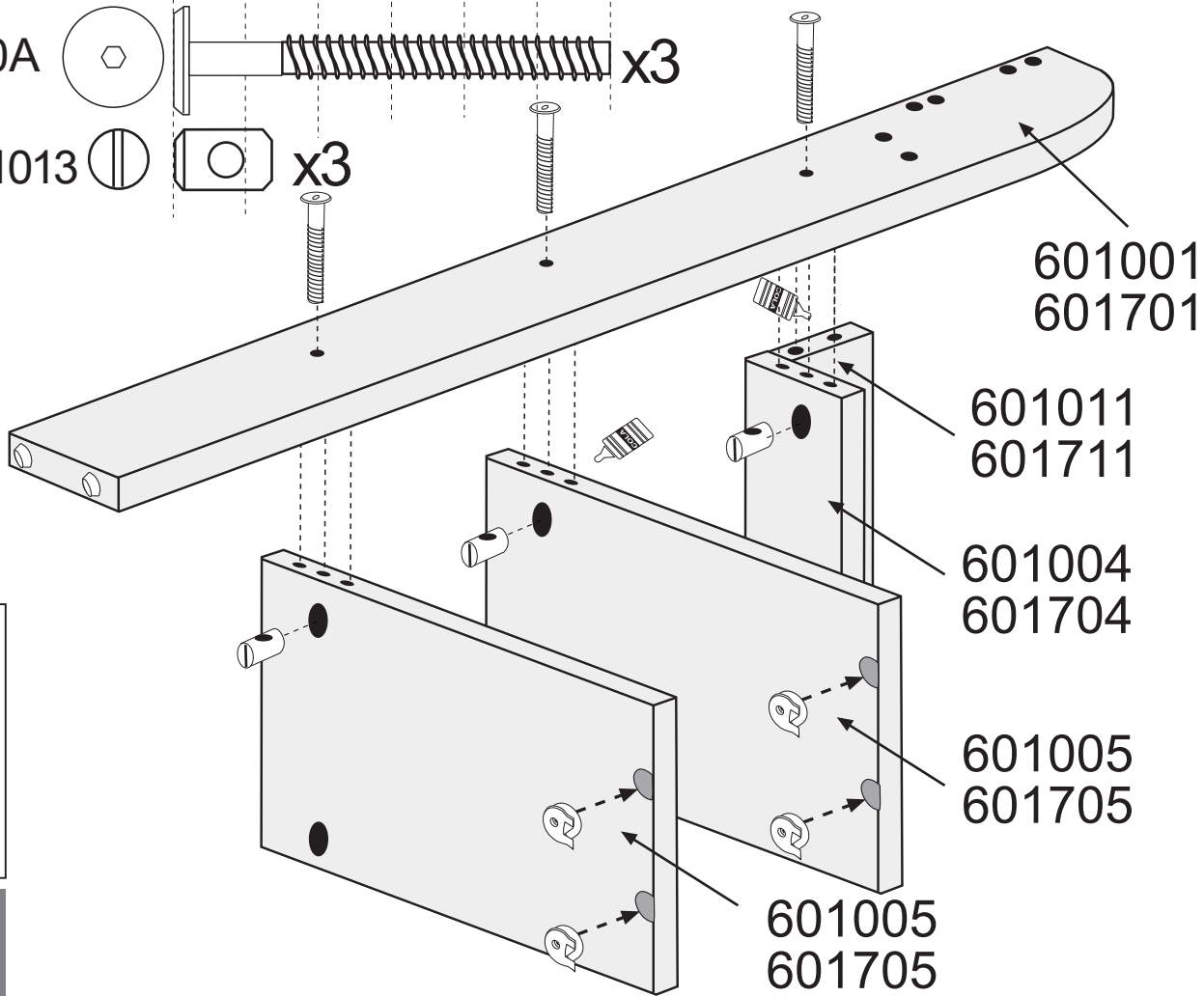

18a

19a

x2

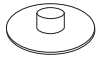

TA3BL

x1



TE17AL
TE17PC

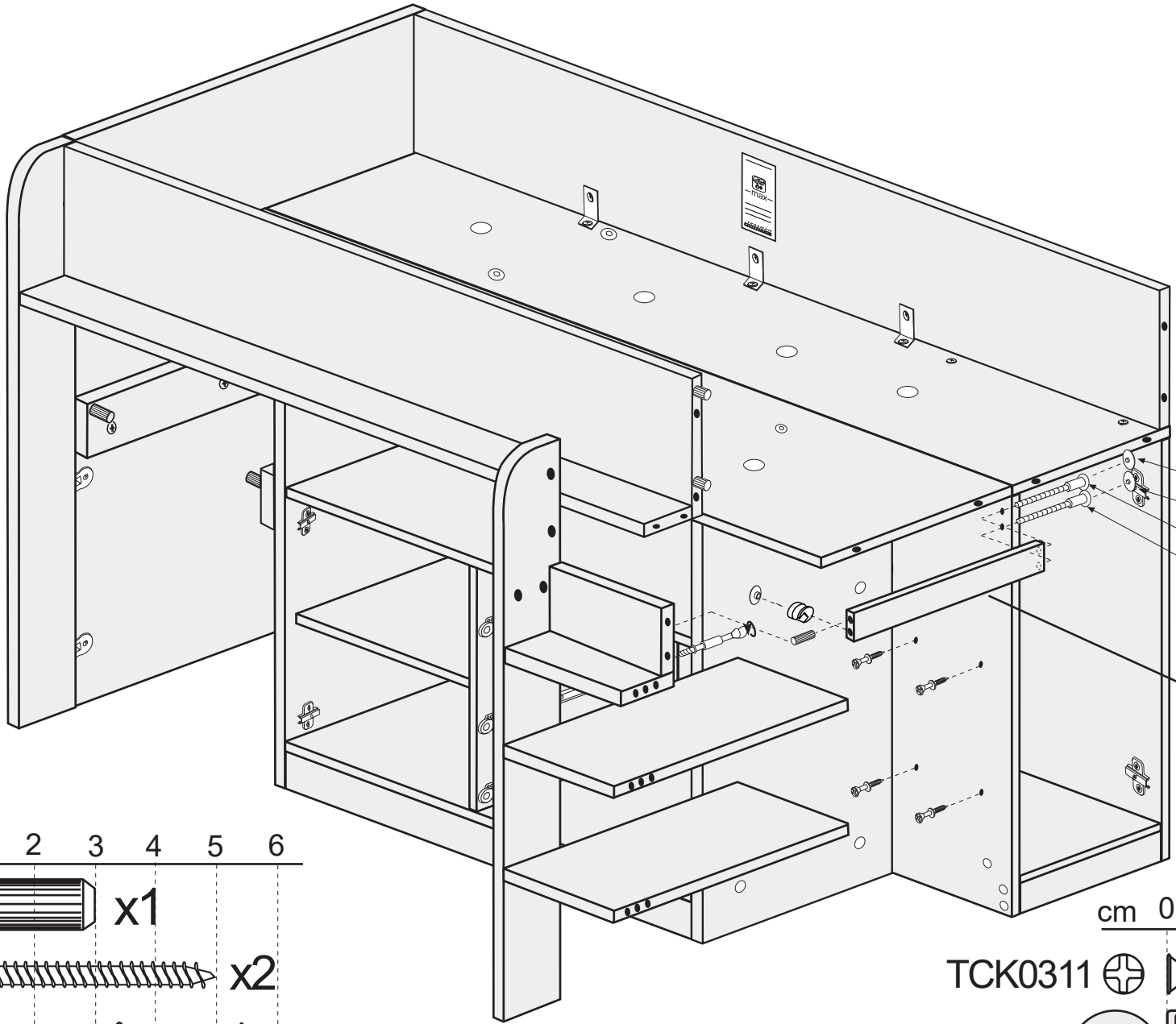
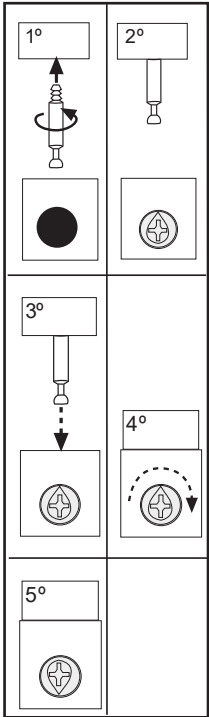

TA3BL
TA3BL
TA550
TA550

601012
601712

cm 0 1 2 3 4 5 6

CL830 x1

TA550 x2

PE845 x1

cm 0 1 2 3

TCK0311 x4

EX25 x1

20a

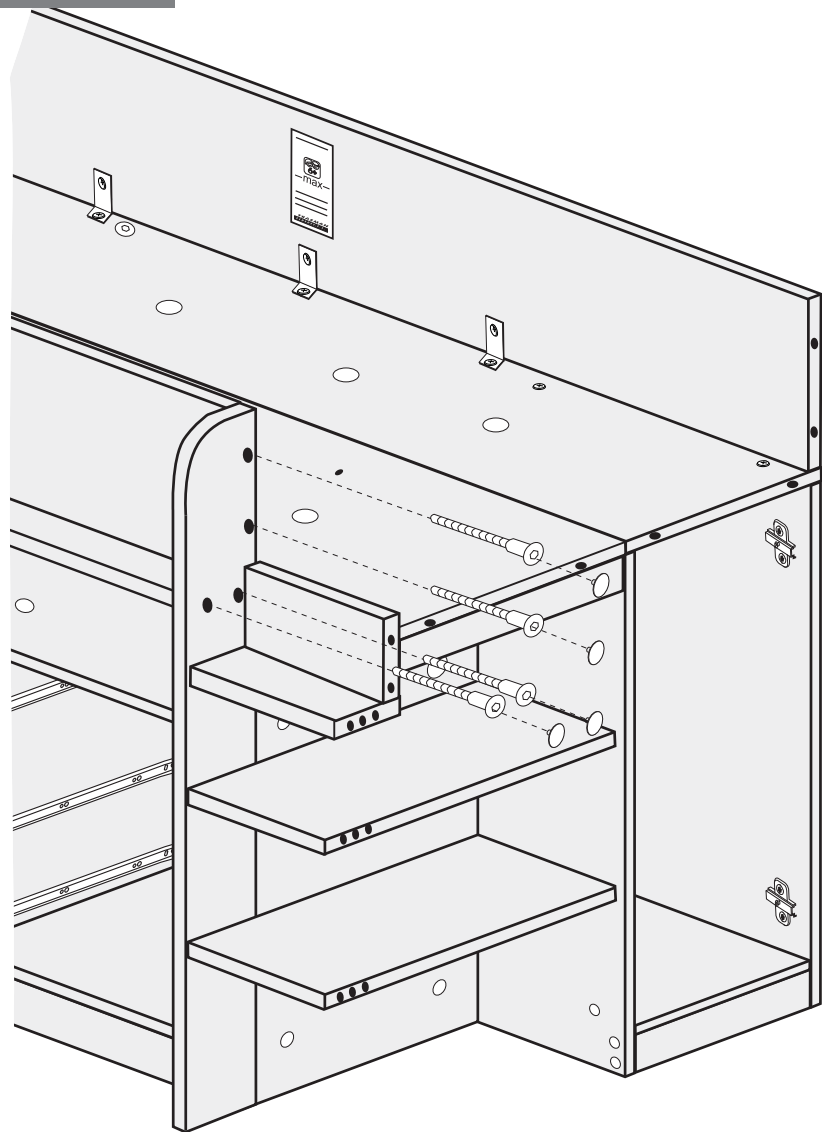

x4



TA4AL
TA4PC

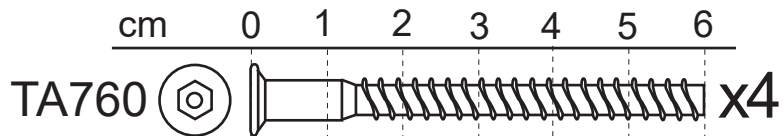

21a

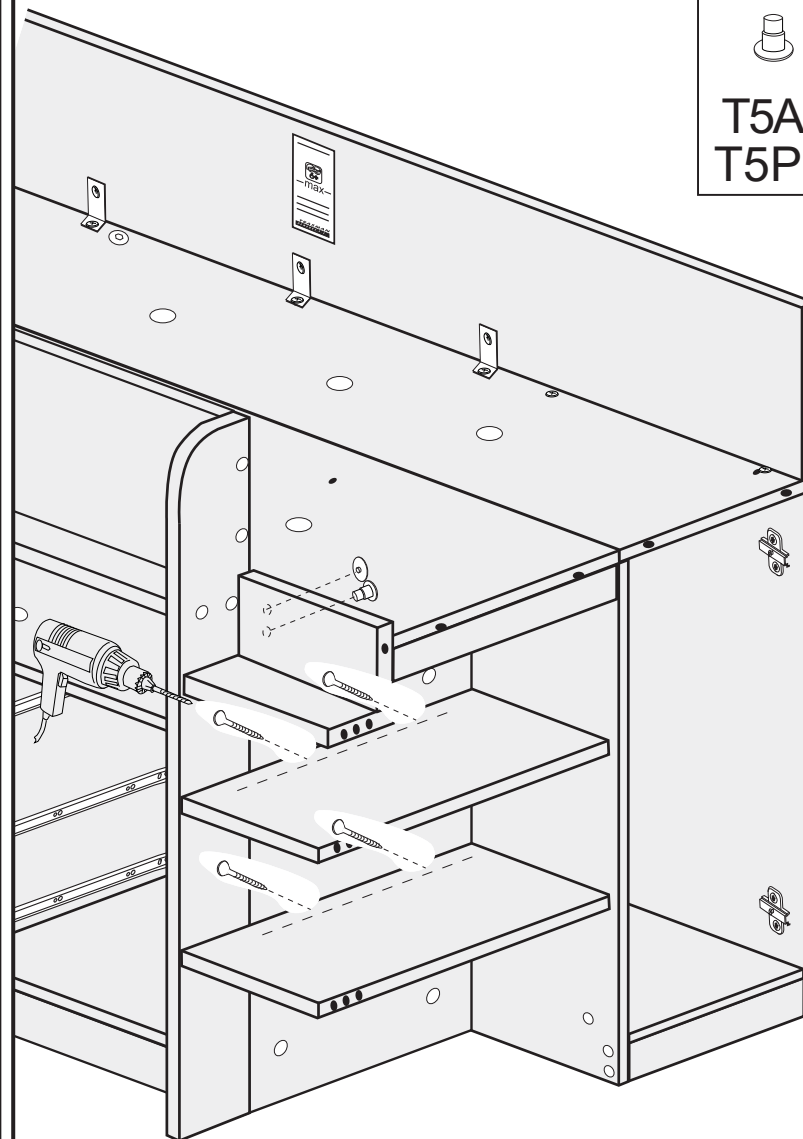

x1



T5AL
T5PC

x1



T8AL
T8PC

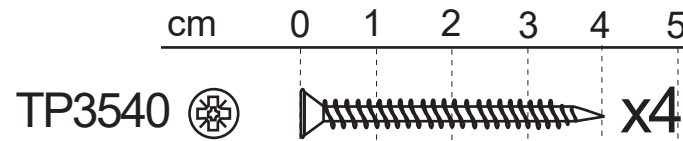

22a

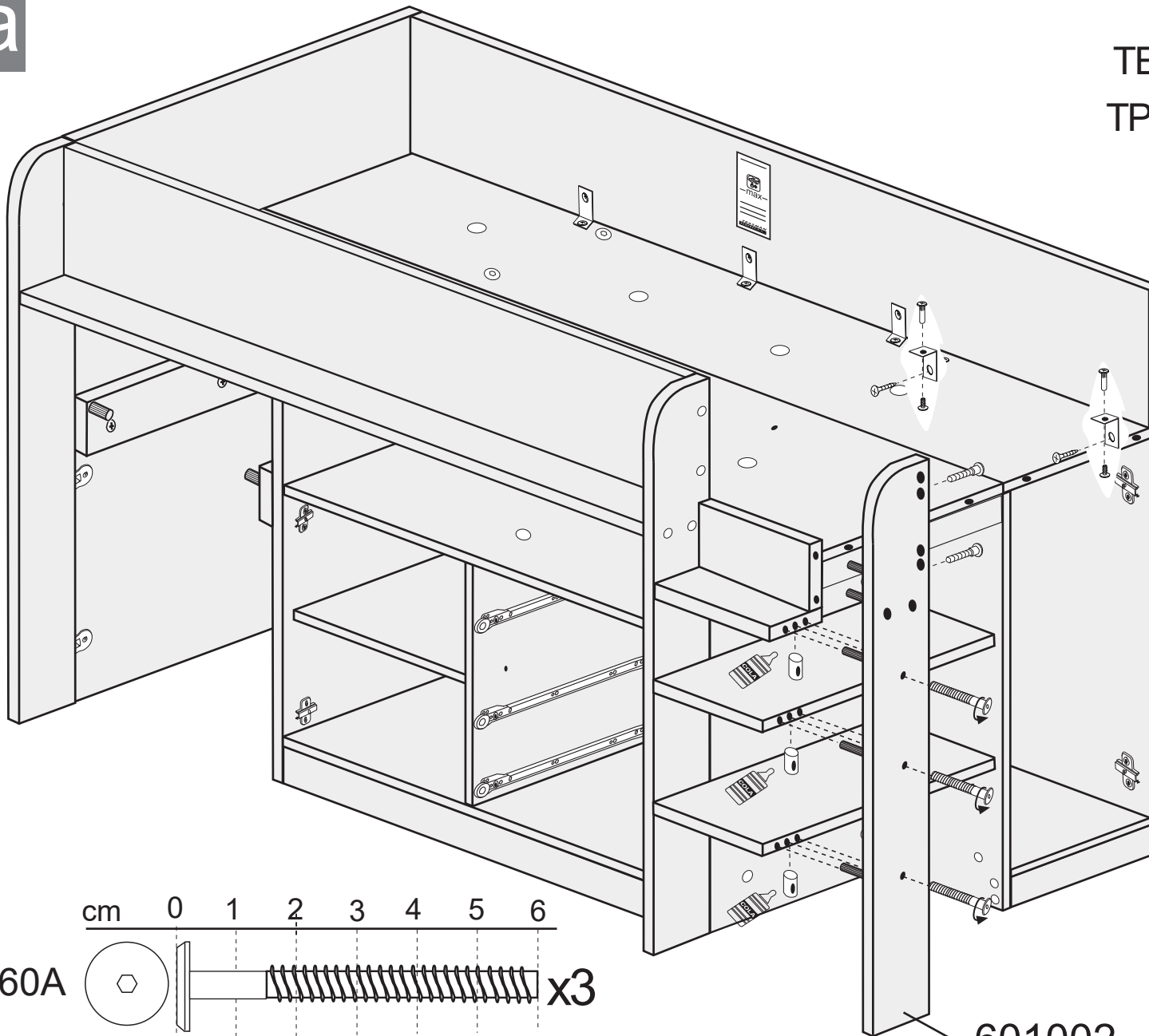

cm 0 1 2 3

TEN513   x2

TP4016   x2

cm 0 1 2 3 4 5 6

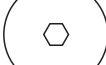
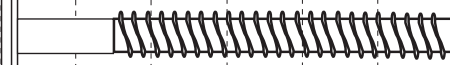
TM660A   x3

TUEM61013   x3

601002
601702

x2

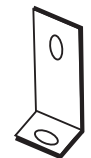

E2136

x2



TUM4

23a

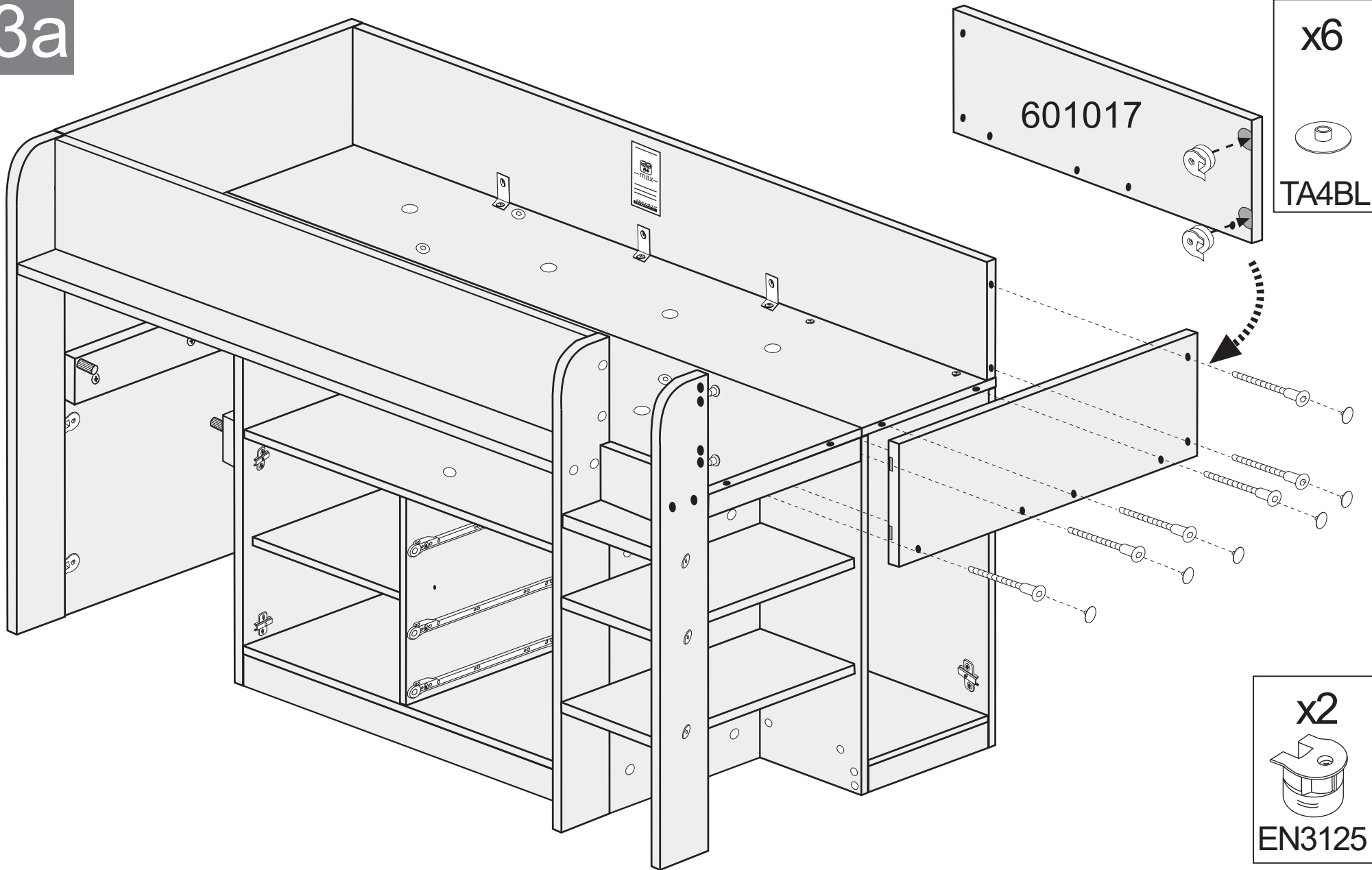

601017

x6

TA4BL

cm 0 1 2 3 4 5 6

TA760

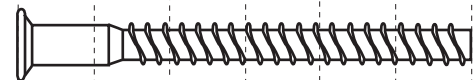

x6

x2

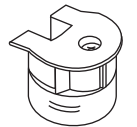

EN3125

24a

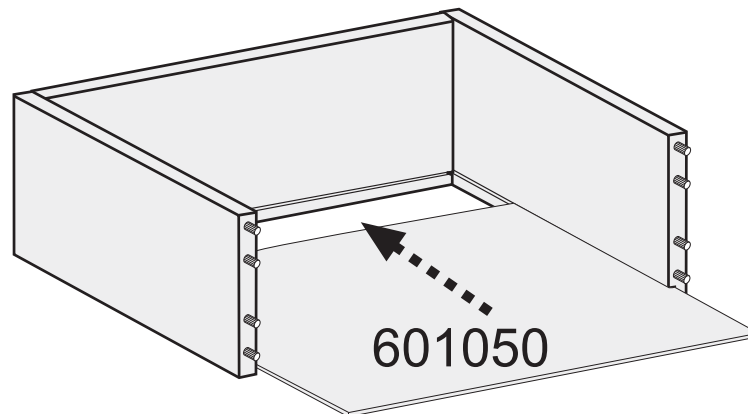
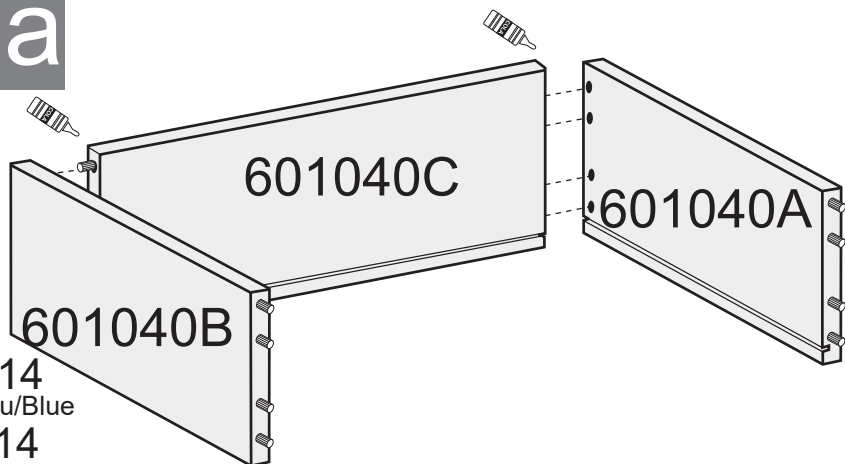

- 601014
Azul/Bleu/Blue
- 601114
Verde/Vert/Green
- 601214
Fucsia/Fuchsia
- 601314
Grafito/Graphite
- 601414
Tornasol/Tournesol/
Sunflower
- 601514
Rojo/Rouge/Red
- 601614
Molina
- 601714
Cascina
- 601814
Azul ahumado /
Smokey Blue /
Bleu fumé
- 601914
Rose Antique / Antique
Pink

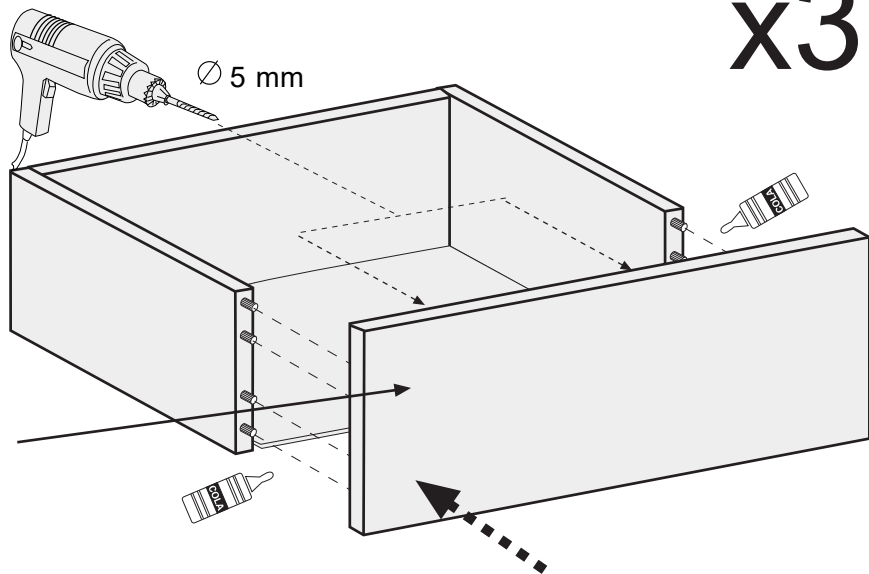

x3

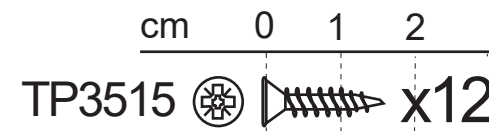
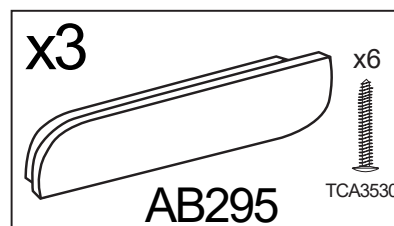
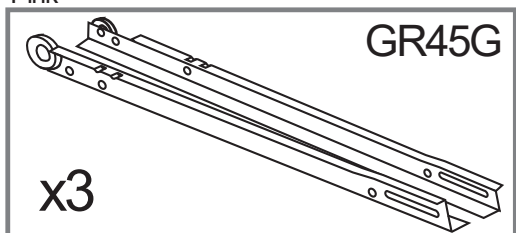
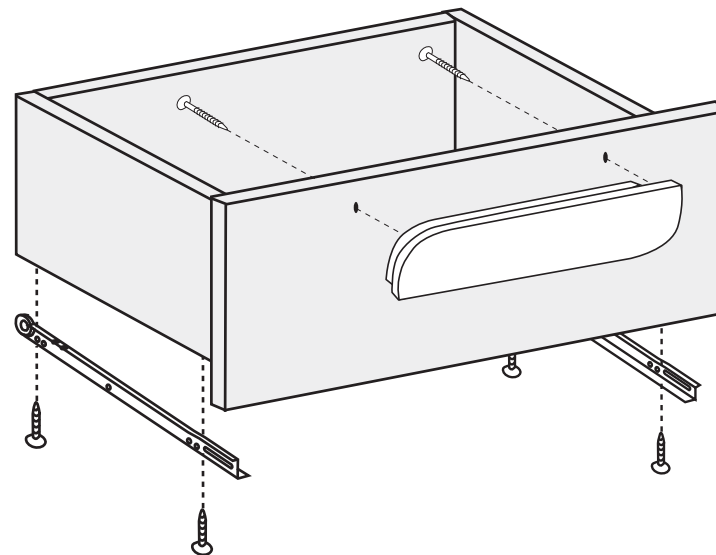

25a

x4

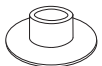

T8AL
T8PC

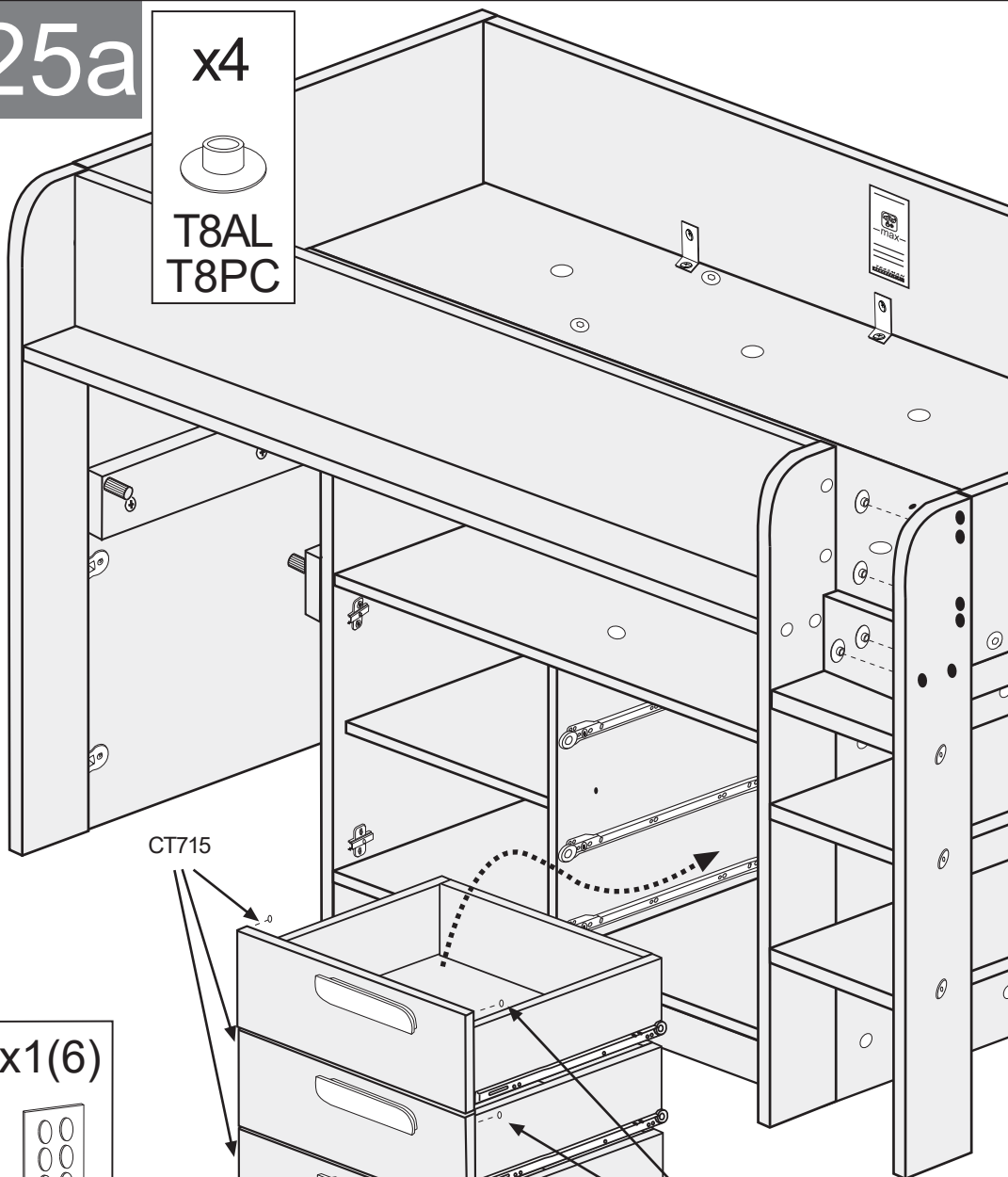

CT715

x1(6)

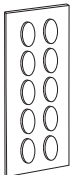

CT715

CT715

26a

x2



T5BL

x4

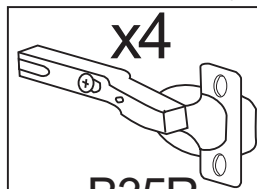

B35R

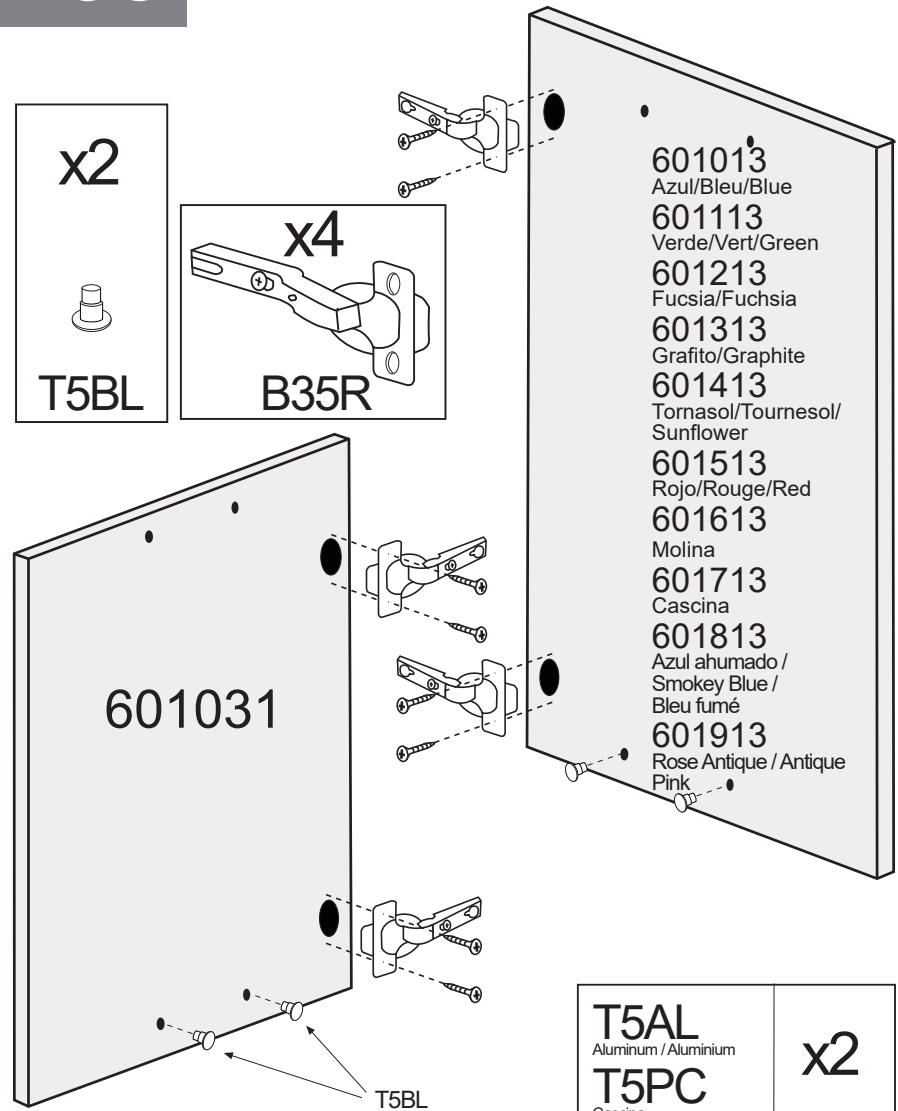

601031

T5BL

cm 0 1 2

TP3515



x8

601013

Azul/Bleu/Blue

601113

Verde/Vert/Green

601213

Fucsia/Fuchsia

601313

Grafito/Graphite

601413

Tomasol/Tournesol/
Sunflower

601513

Rojo/Rouge/Red

601613

Molina

601713

Cascina

601813

Azul ahumado /
Smokey Blue /
Bleu fumé

601913

Rose Antique / Antique
Pink

T5AL

Aluminum / Aluminium

T5PC

Cascina

T5AH

Azul ahumado / Smokey
Blue / Bleu fumé

T5RA

Rose Antique / Antique
Pink

x2



T5*

27a

- 601016 Azul/Bleu/Blue
- 601116 Verde/Vert/Green
- 601216 Fucsia/Fuchsia
- 601316 Grafito/Graphite
- 601416 Tornasol/Tournesol/Sunflower
- 601516 Rojo/Rouge/Red
- 601616 Molina
- 601716 Cascina
- 601816 Azul ahumado / Smokey Blue / Bleu fumé
- 601916 Rose Antique / Antique Pink

cm 0 1 2 3 4 5

CL830   x14

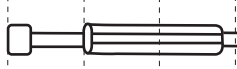
PE845   x12

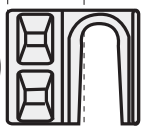
EX25   x12

TP2516   x4

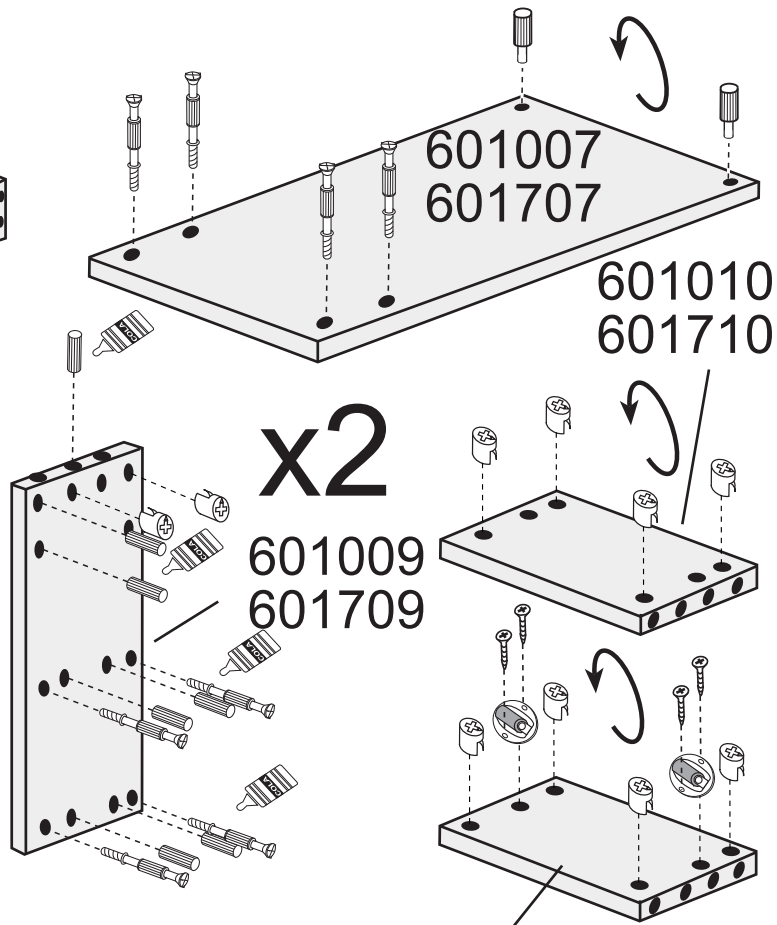

x2

601010
601710

x2

CT8B

x2

RTD20

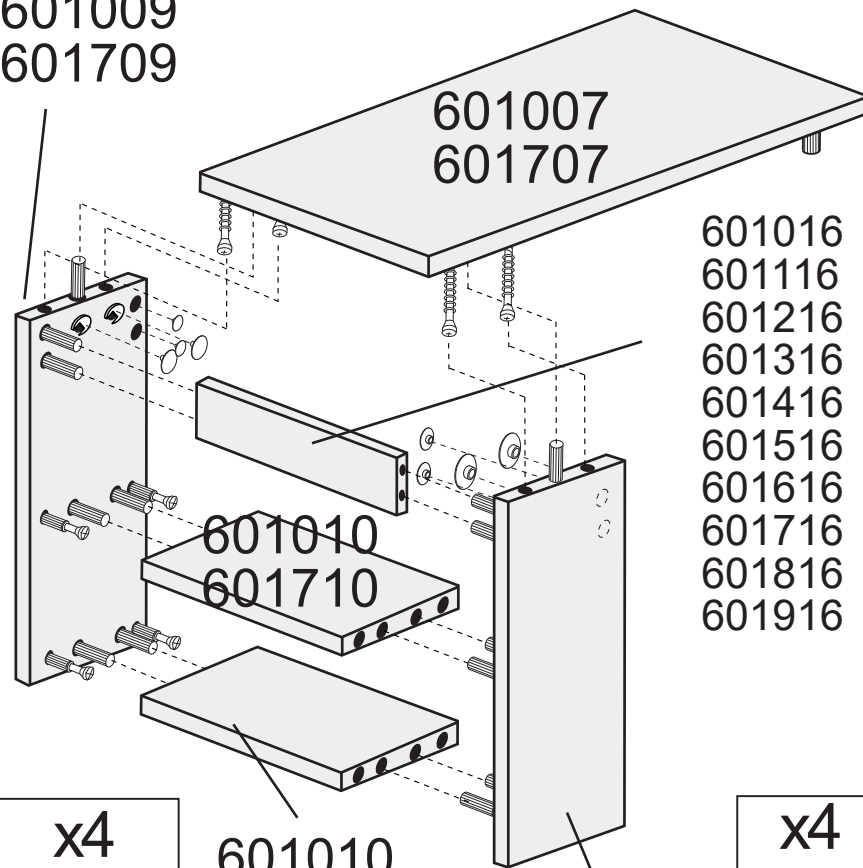
28a

601009
601709



601007
601707

- 601016
- 601116
- 601216
- 601316
- 601416
- 601516
- 601616
- 601716
- 601816
- 601916

x4

TE17AL
TE17PC

601010
601710

601009
601709

x4

T8AL
T8PC

29a

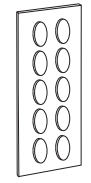
x1(4)



CT715

x6

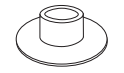

T8AL
T8PC

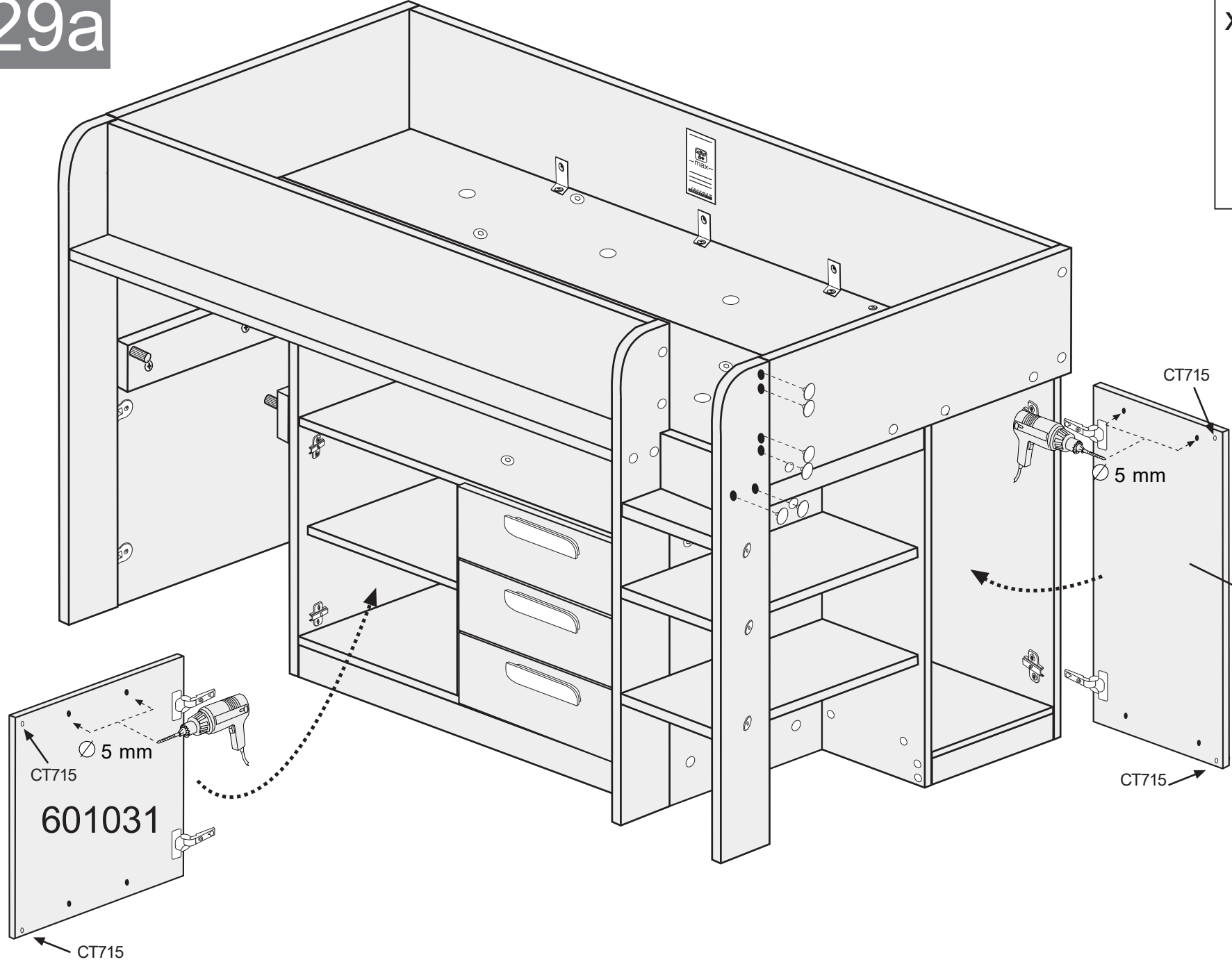

CT715

5 mm

CT715

CT715

601031

CT715

- 601013
- 601113
- 601213
- 601313
- 601413
- 601513
- 601613
- 601713
- 601813
- 601913

30a

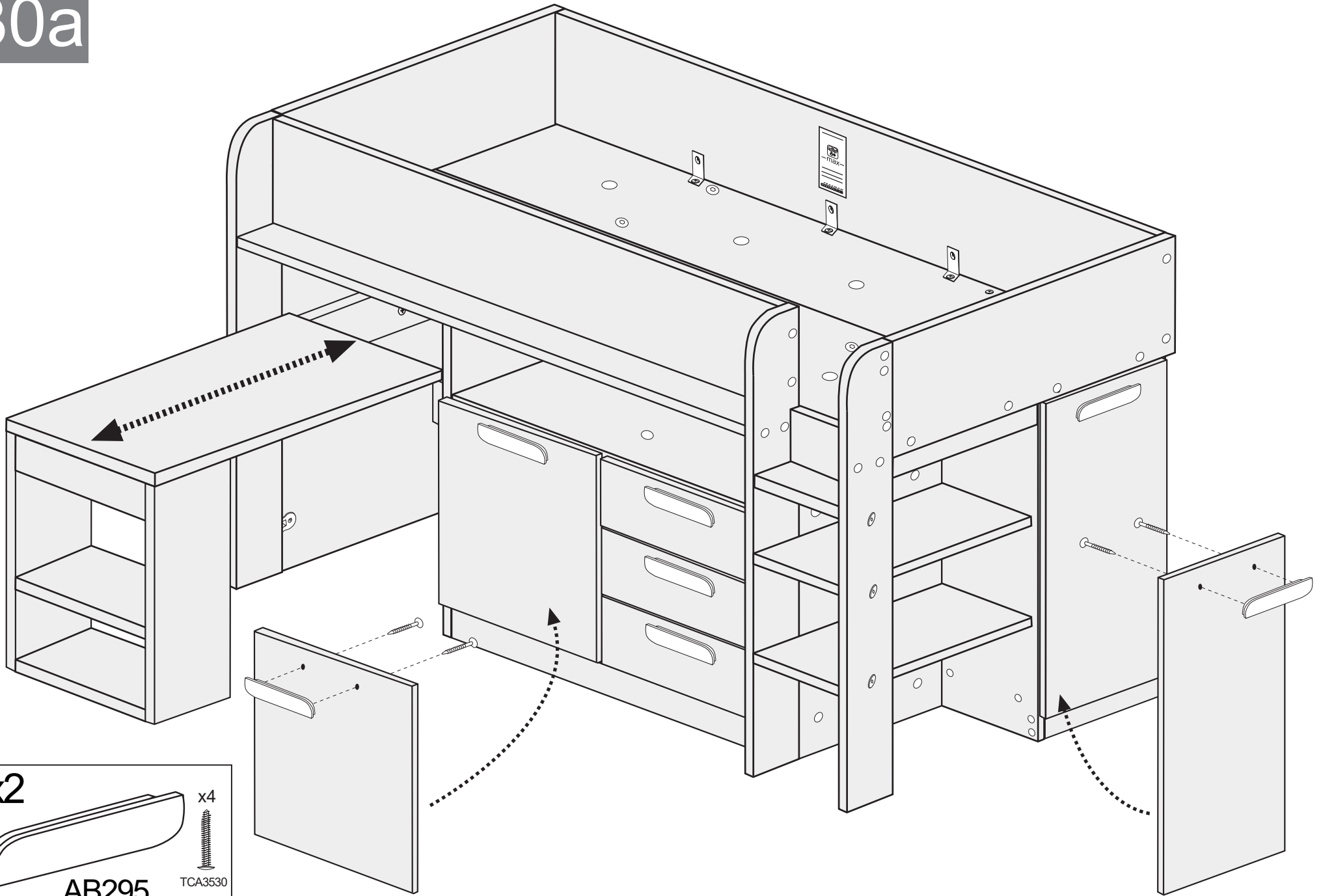

x2



AB295

x4



TCA3530

cm 0 1 2 3 4

TP3515  x4

TP3535  x4

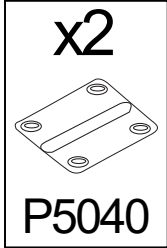

TP3535

TP3515

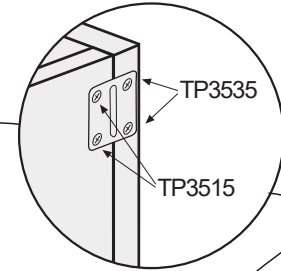

TP3515

TP3535

TP3515

no incluido
not included
pas inclus
não incluído

2000x900 mm

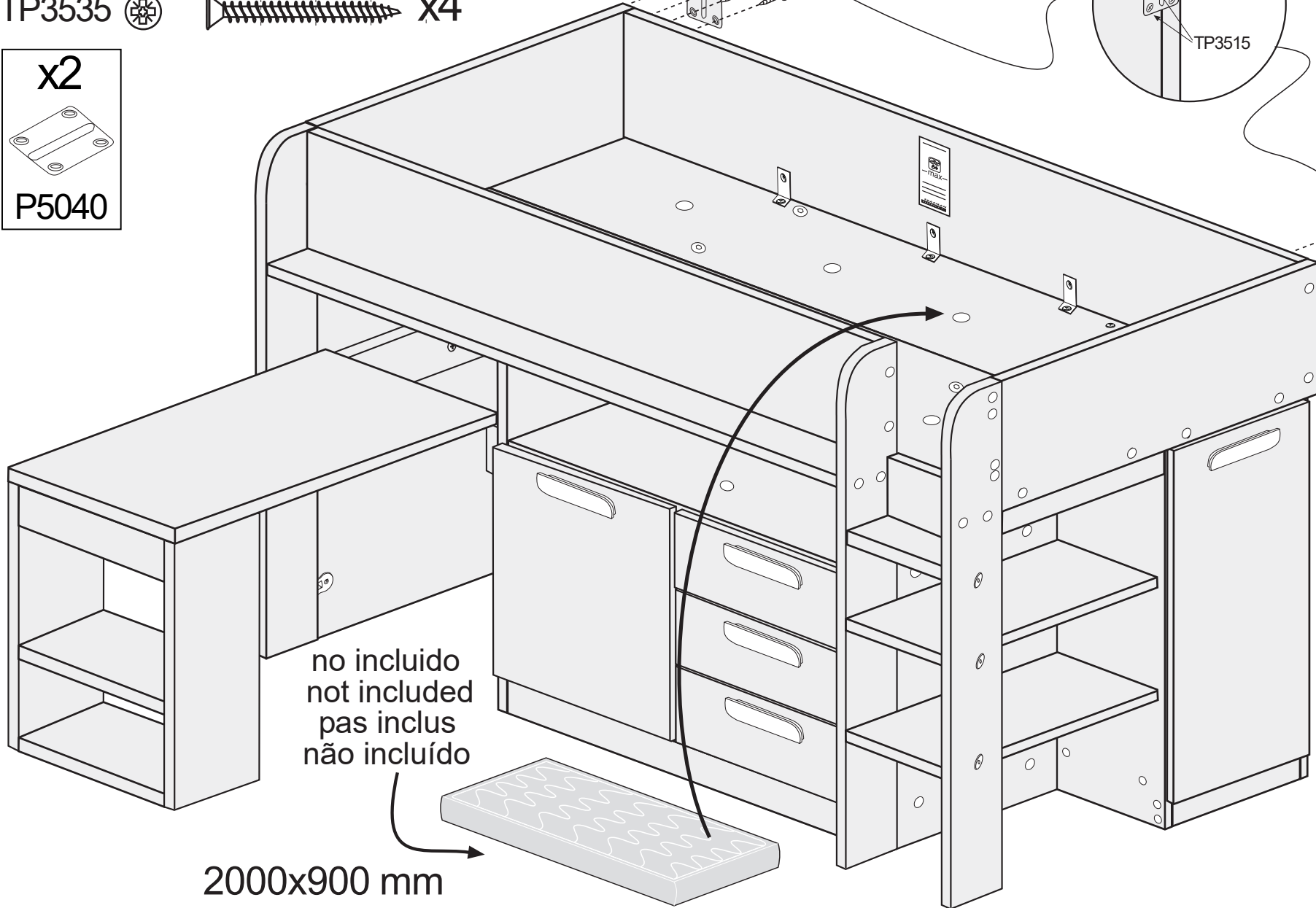
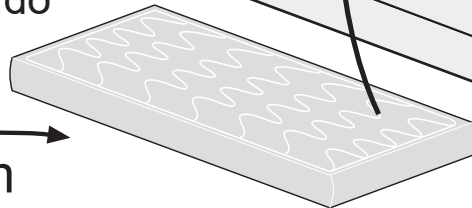

1b

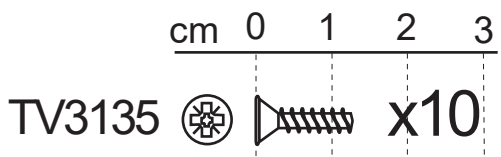
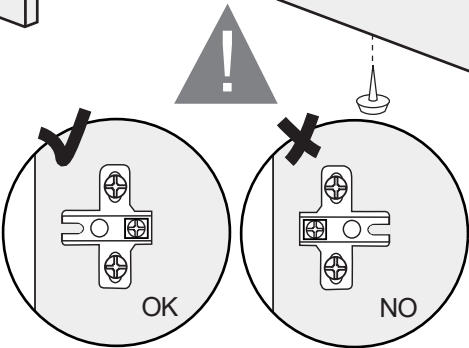
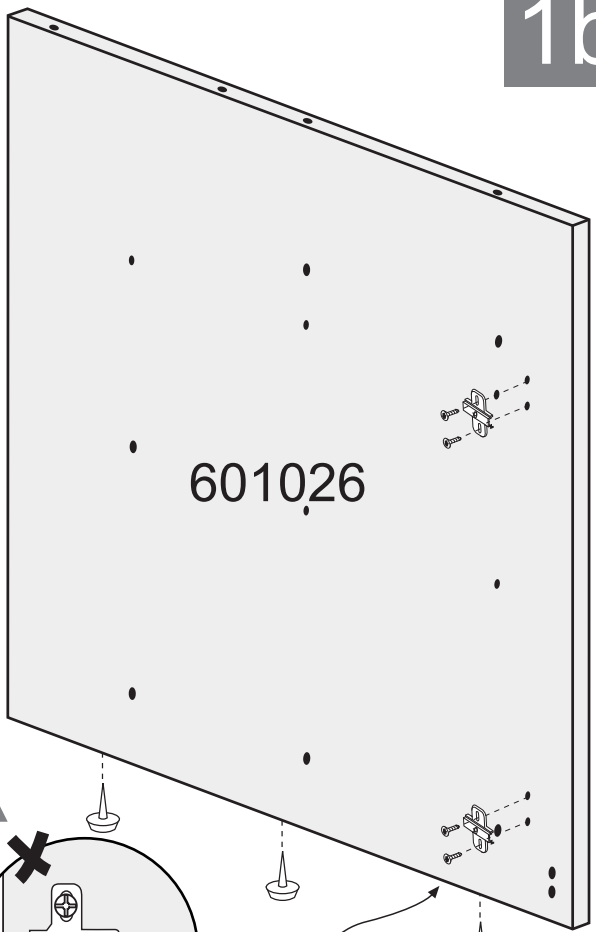
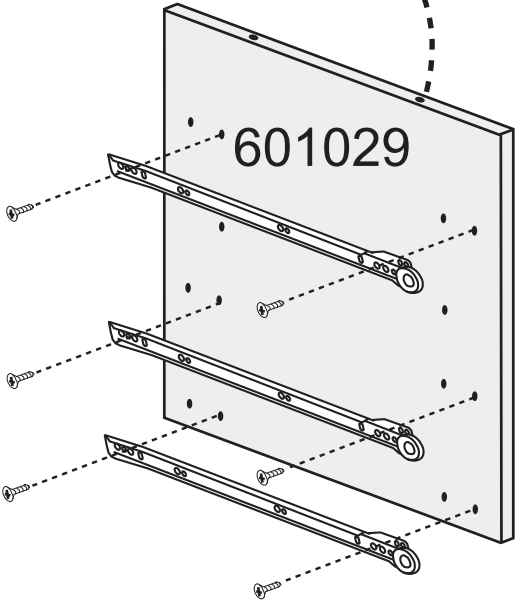
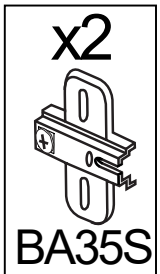
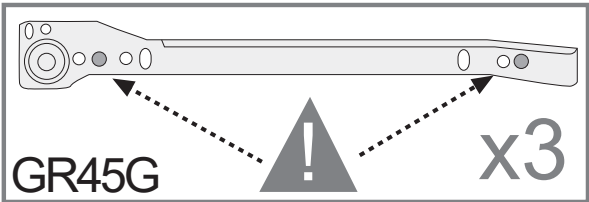

2b

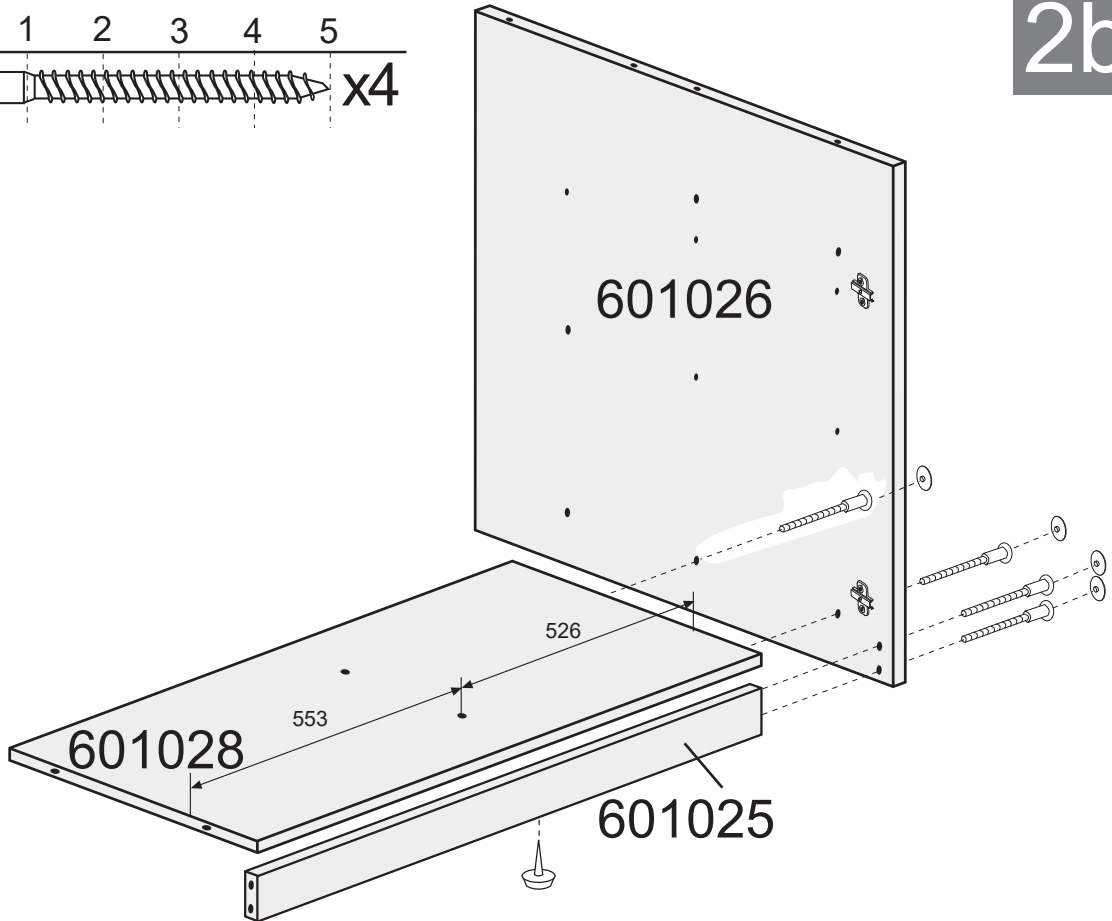
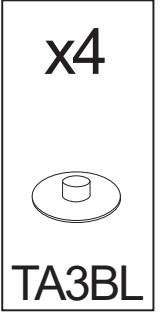
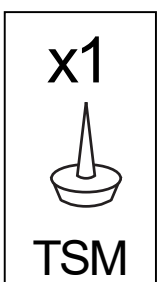
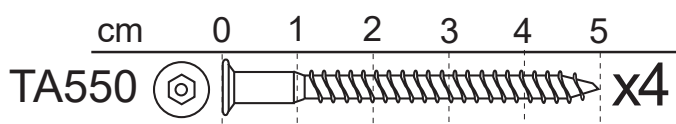

3b

cm 0 1 2 3 4 5

TA550  x4

CL830  x2

x2



TSM

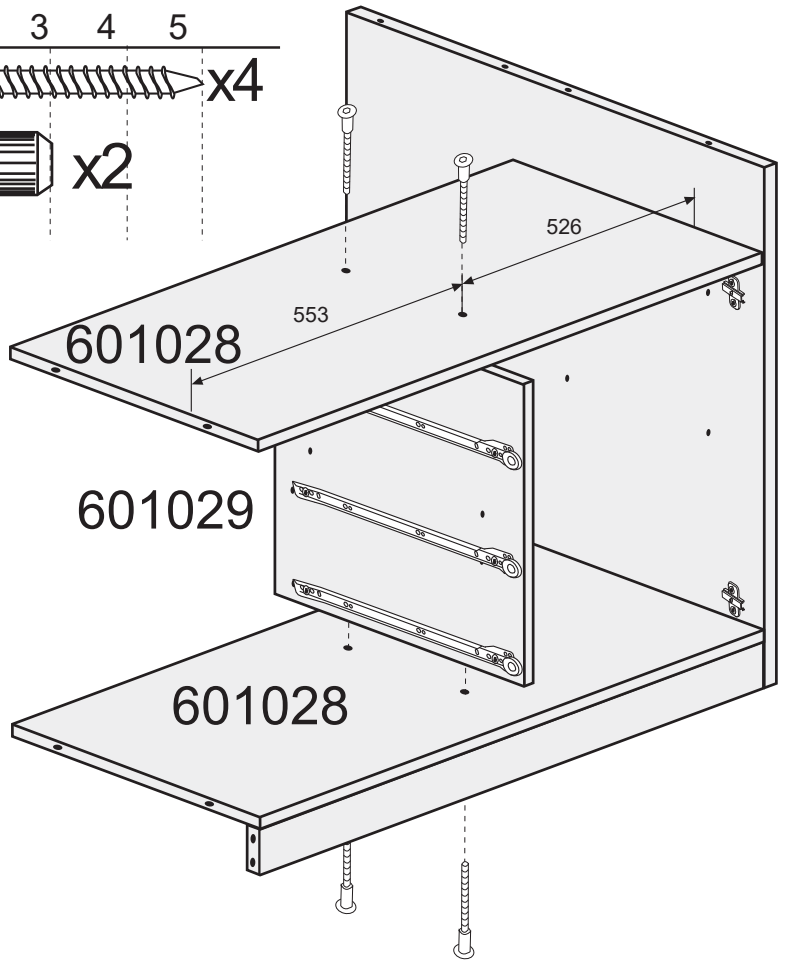
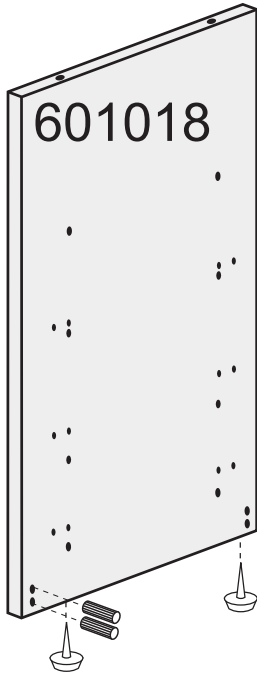

cm 0 1 2 3 4 5 6

TA760  x4

TA550  x2

4b

TA550

TA550

x4



TA3BL

x1

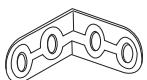

EA3030

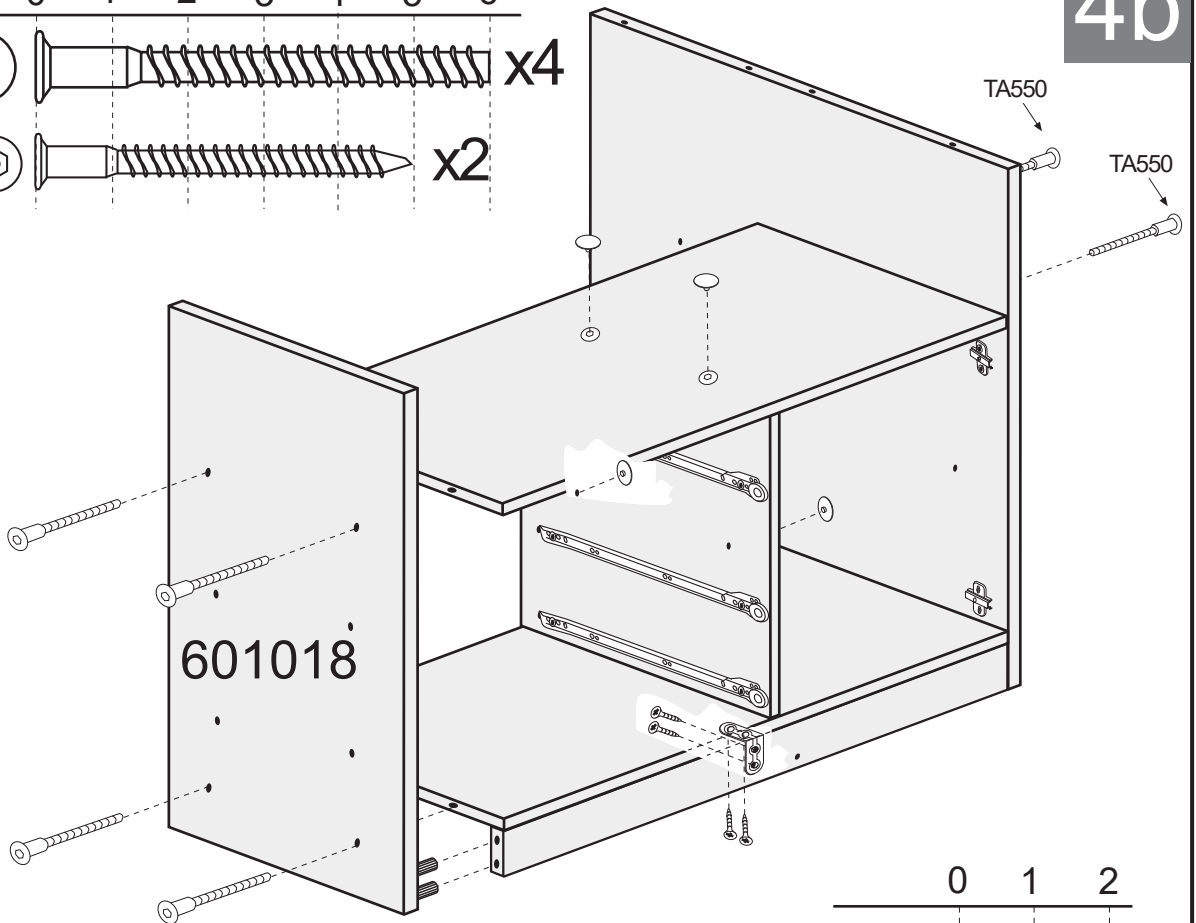

0 1 2

TP3515  x4

5b

x4



PE3

601008
601708

601026

TC2027 x3

TC2027

TC2027

TC2027

cm 0 1 2 3

TV3135 x6

601030

x3

GR45G



cm 0 1 2 3 4 5 6

TA760 x2

TC2027 x3

601008
601708

601019

TA4BL

TA4BL

x3

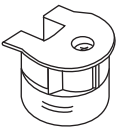

EN3125

x2



TSM

x3



TA3BL

x2



TA4BL

601034

6b

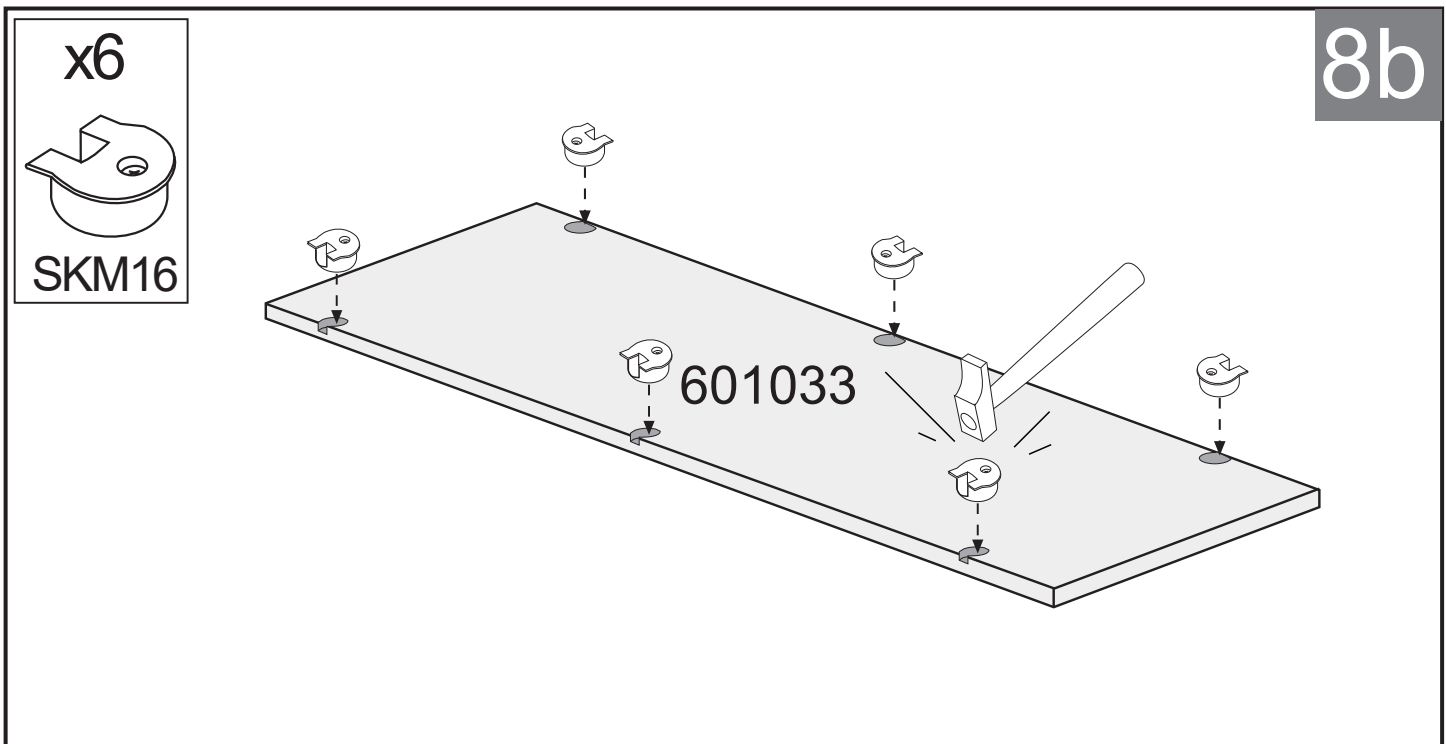
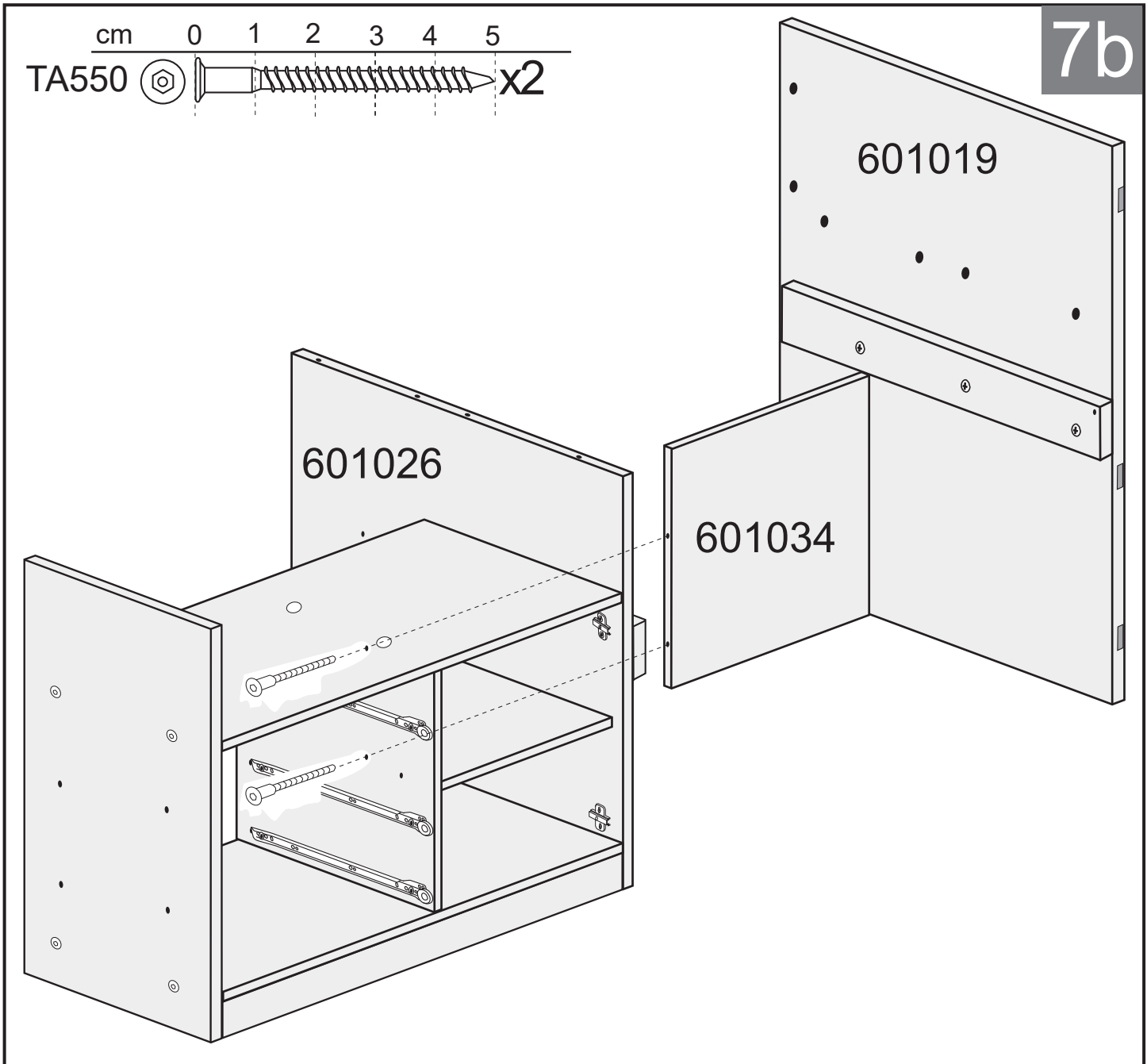

9b

x4



TSM

x4



PE3

cm 0 1 2 3

TCK0311  x6

TV3135  x4

x2

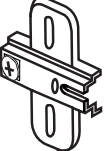

BA35S

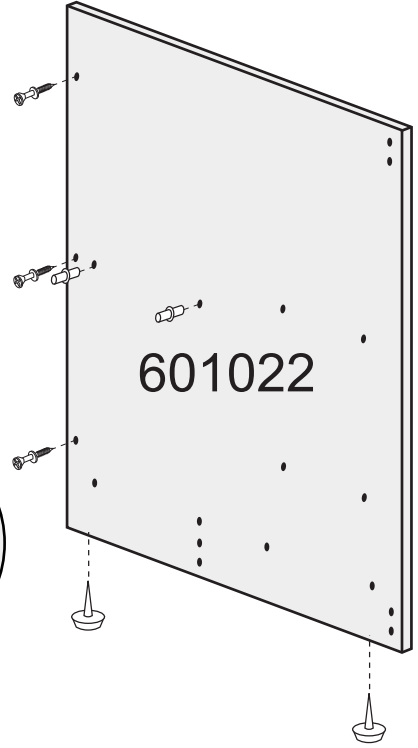
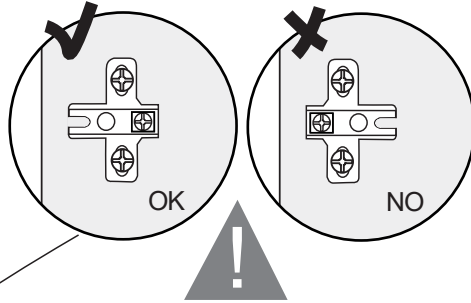
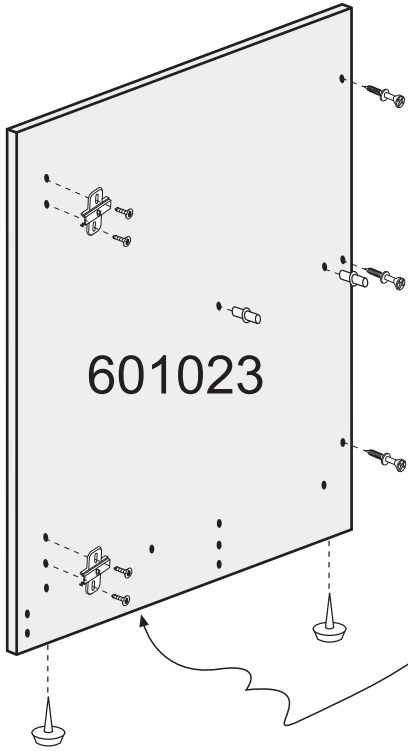

10b

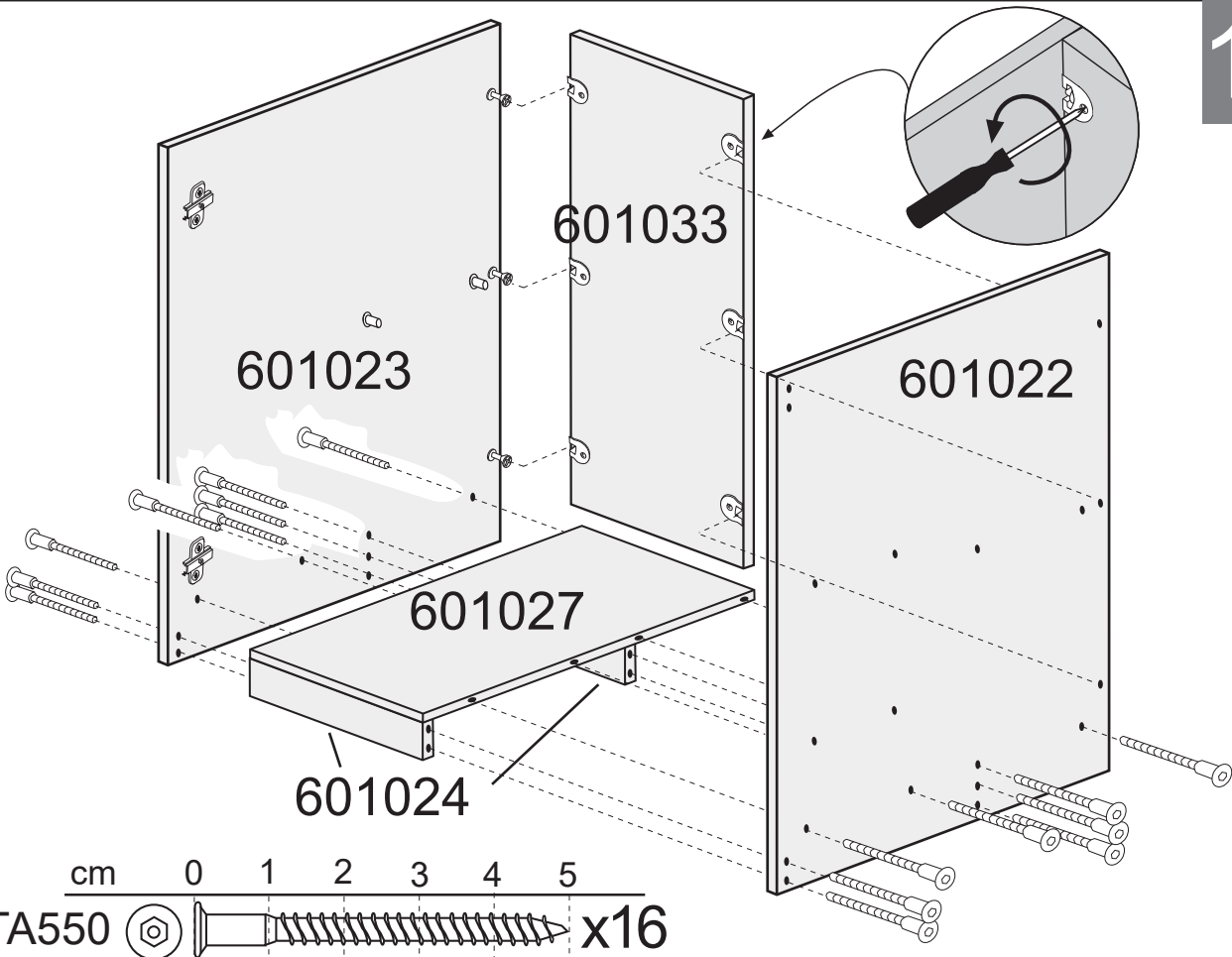

x4
TSM

cm 0 1 2 3 4

TP3540 x4

TEN513 x3

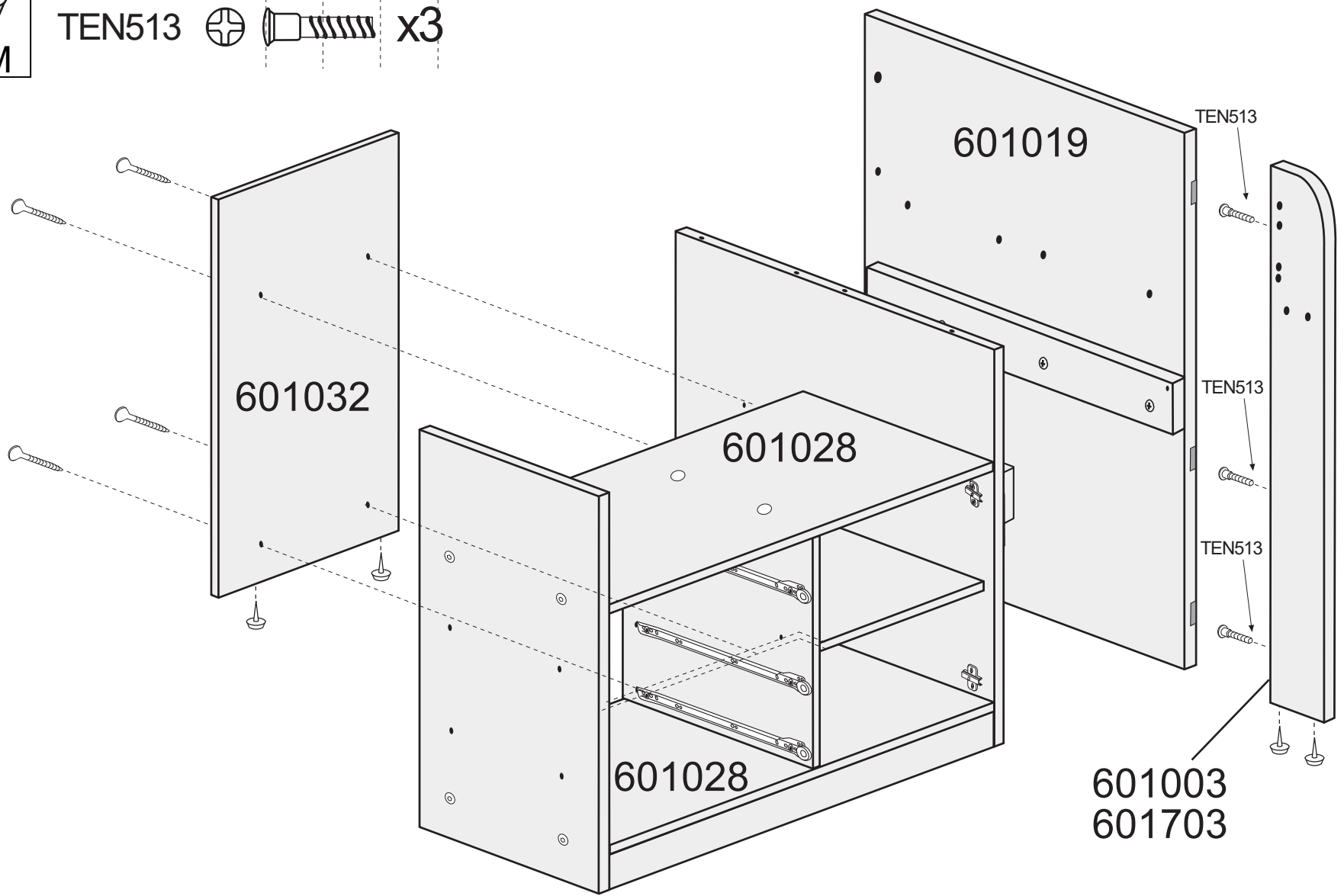

x2
SBO22P

cm 0 1 2
TP3515 x4

BA433
x1

12b

x4
TA4BL

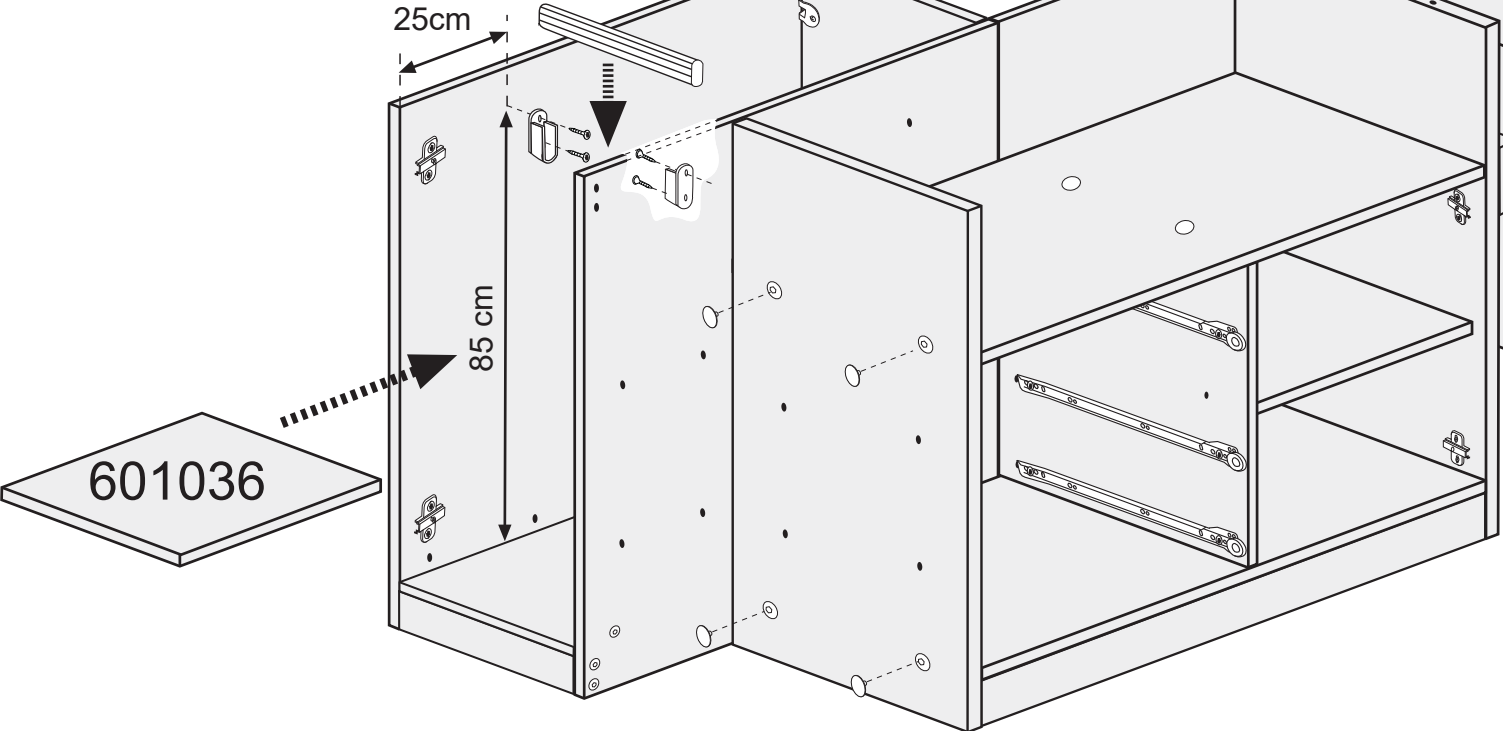
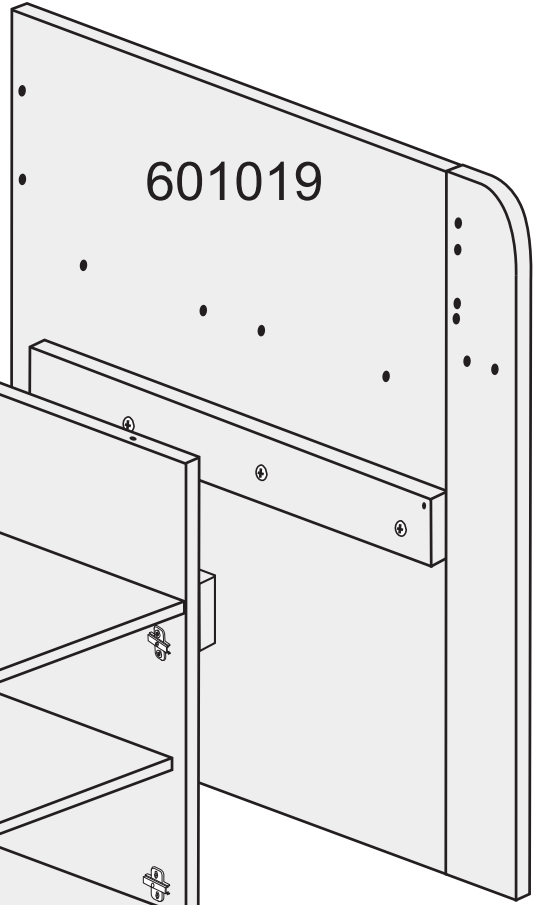
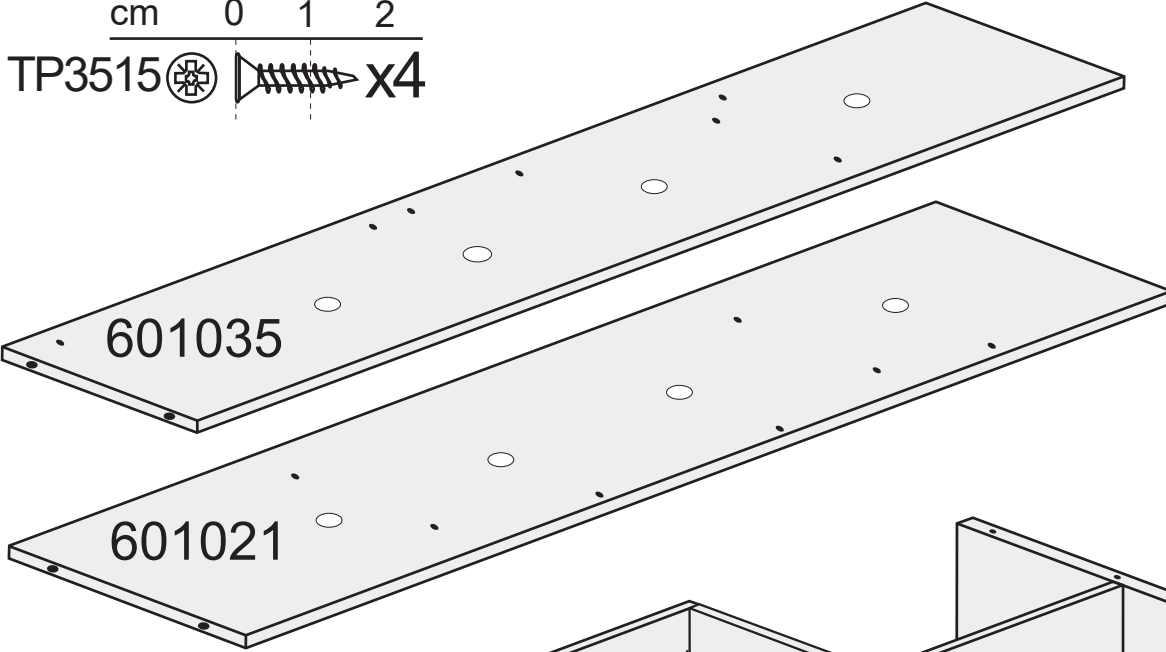

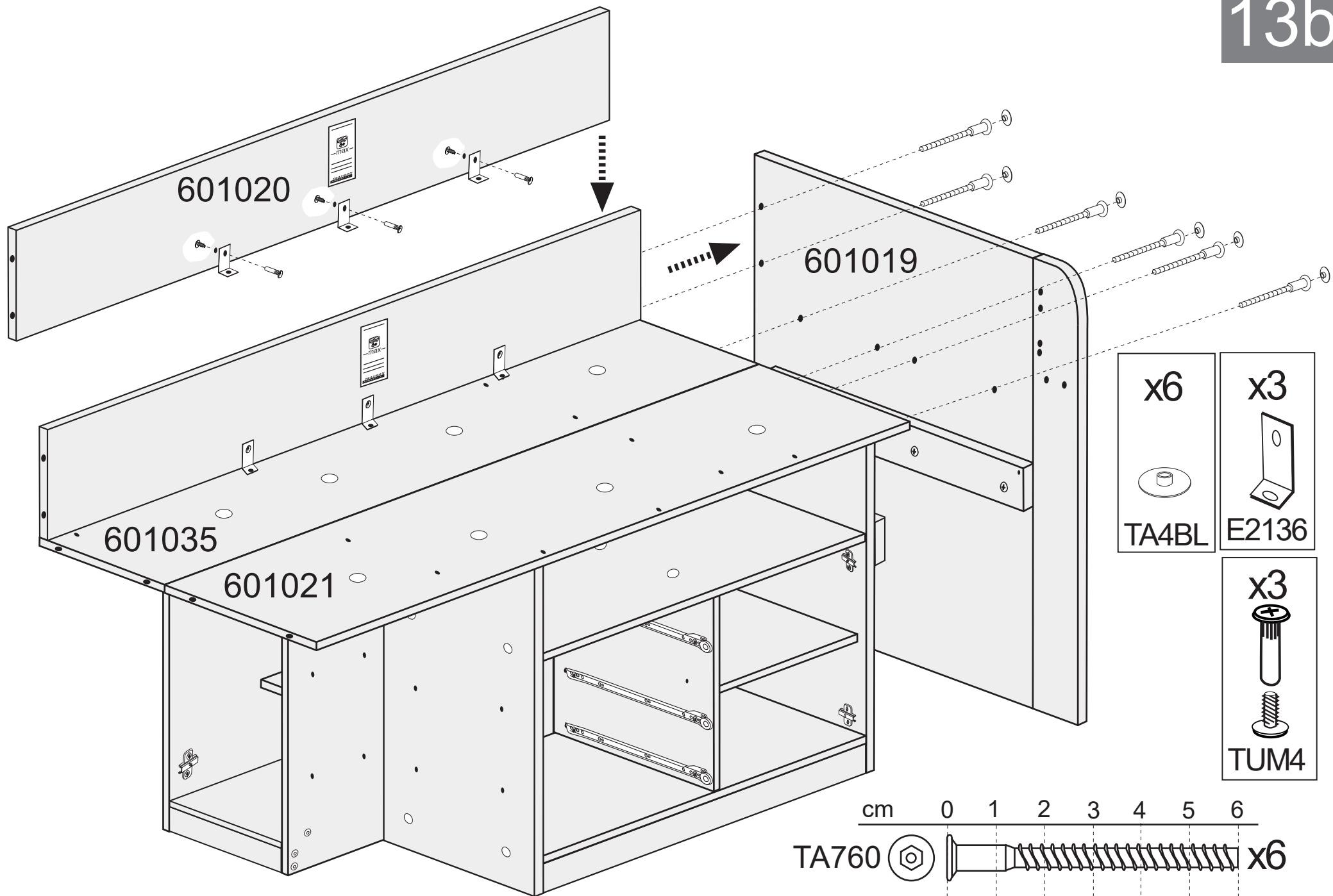

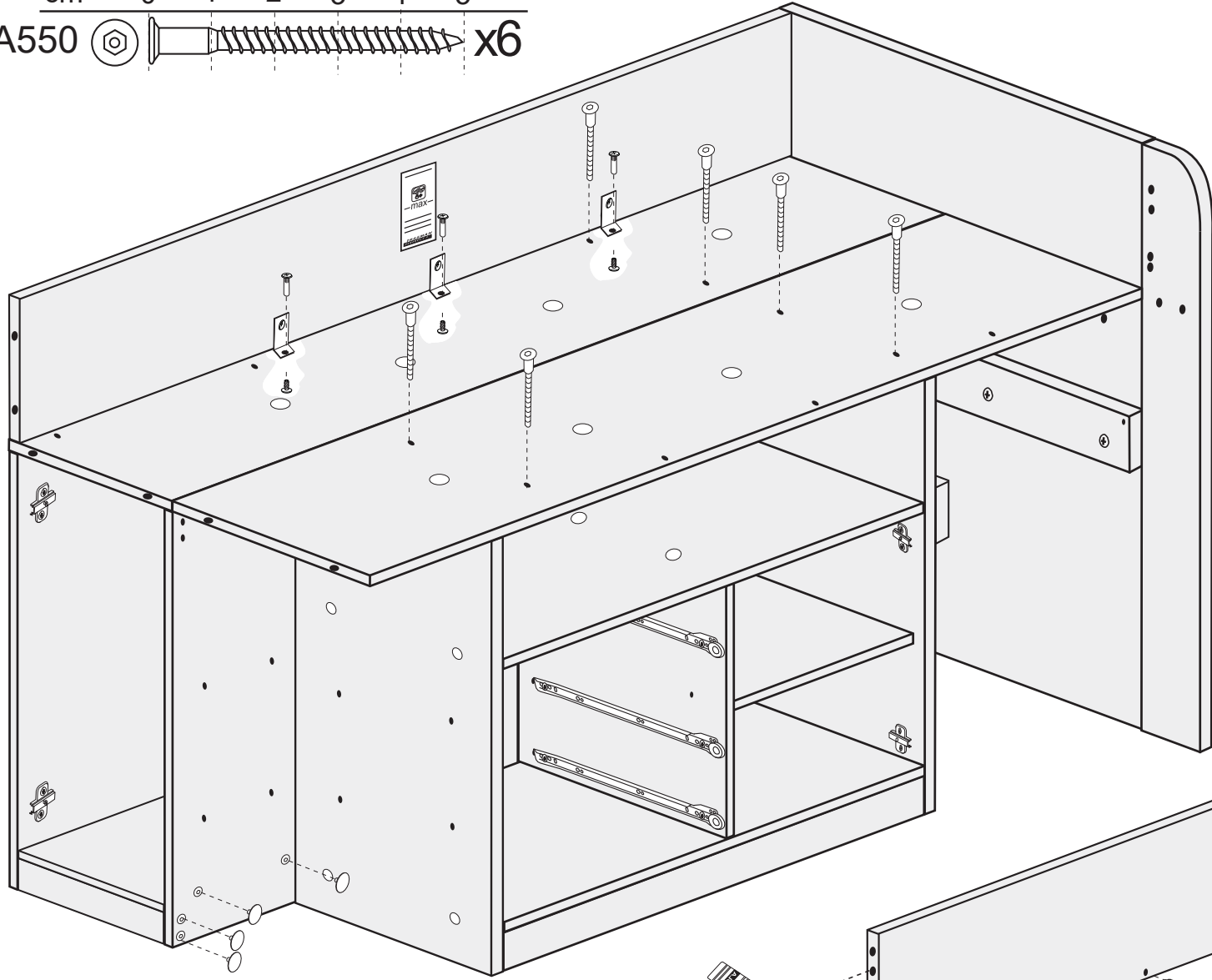

cm 0 1 2 3 4 5
TA550  x6



- 601015 Azul/Bleu/Blue
- 601115 Verde/Vert/Green
- 601215 Fucsia/Fuchsia
- 601315 Grafito/Graphite
- 601415 Tornasol/Tourne sol/Sunflower
- 601515 Rojo/Rouge/Red
- 601615 Molina
- 601715 Cascina

x3





TUM4

x4

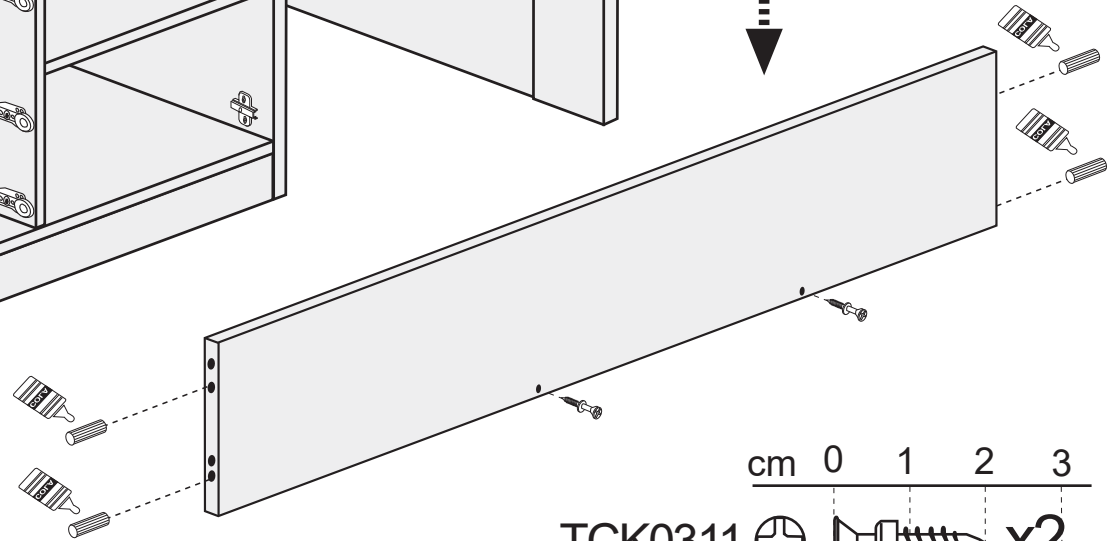

TA3BL



cm 0 1 2 3 4
CL830  x4

cm 0 1 2 3
TCK0311  x2

x3



E2136

x2



SKM16

cm 0 1 2 3

TV5135



x3

601015 / 601115 / 601215
601315 / 601415 / 601515
601615 / 601715

x3



TUM4

x2

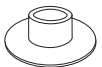

T8AL
T8PC

x2



TA4AL
TA4PC

cm 0 1 2 3 4 5 6

TA760

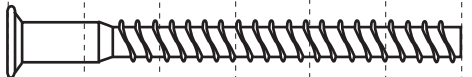

x2

601006
601706

15b

16b

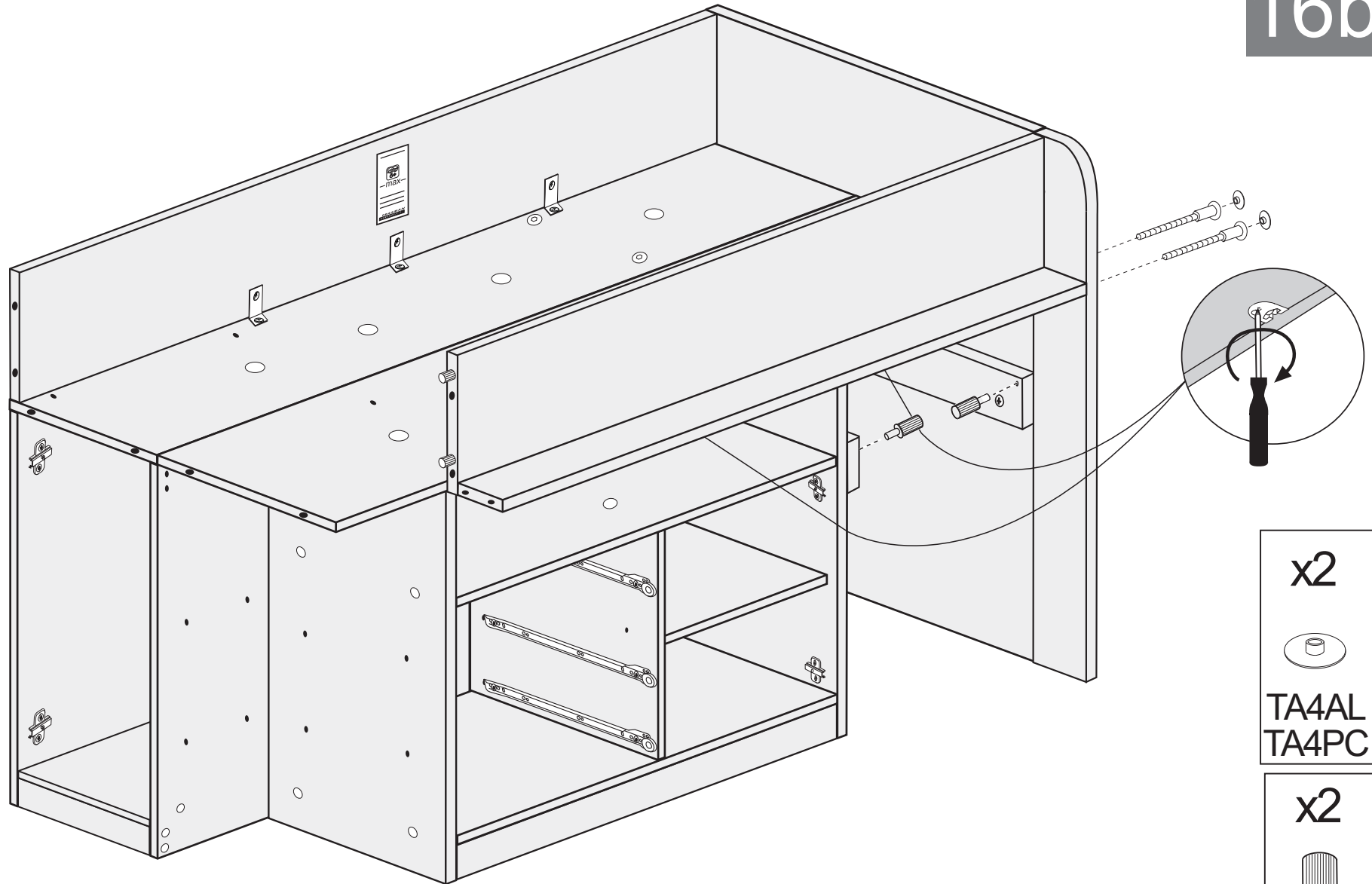

x2



TA4AL
TA4PC

x2



CT8B

cm 0 1 2 3 4 5 6

TA760  x2

17b

cm 0 1 2 3 4 5 6 7

CL1070



x12

CL830



x4

x2



T5AL
T5PC

601002
601702

601001
601701

x4



TSM

cm 0 1 2 3 4 5 6

TM660A

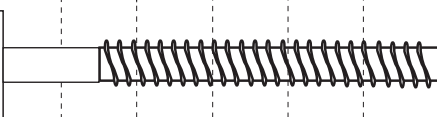
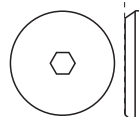

x3

601002
601702

601011
601711

601004
601704

601005
601705

601005
601705

x4



SKM16

cm 0 1 2

TUEM61013

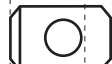

x3

18b

- x1**
TE17AL
TE17PC
- x2**
TA3BL

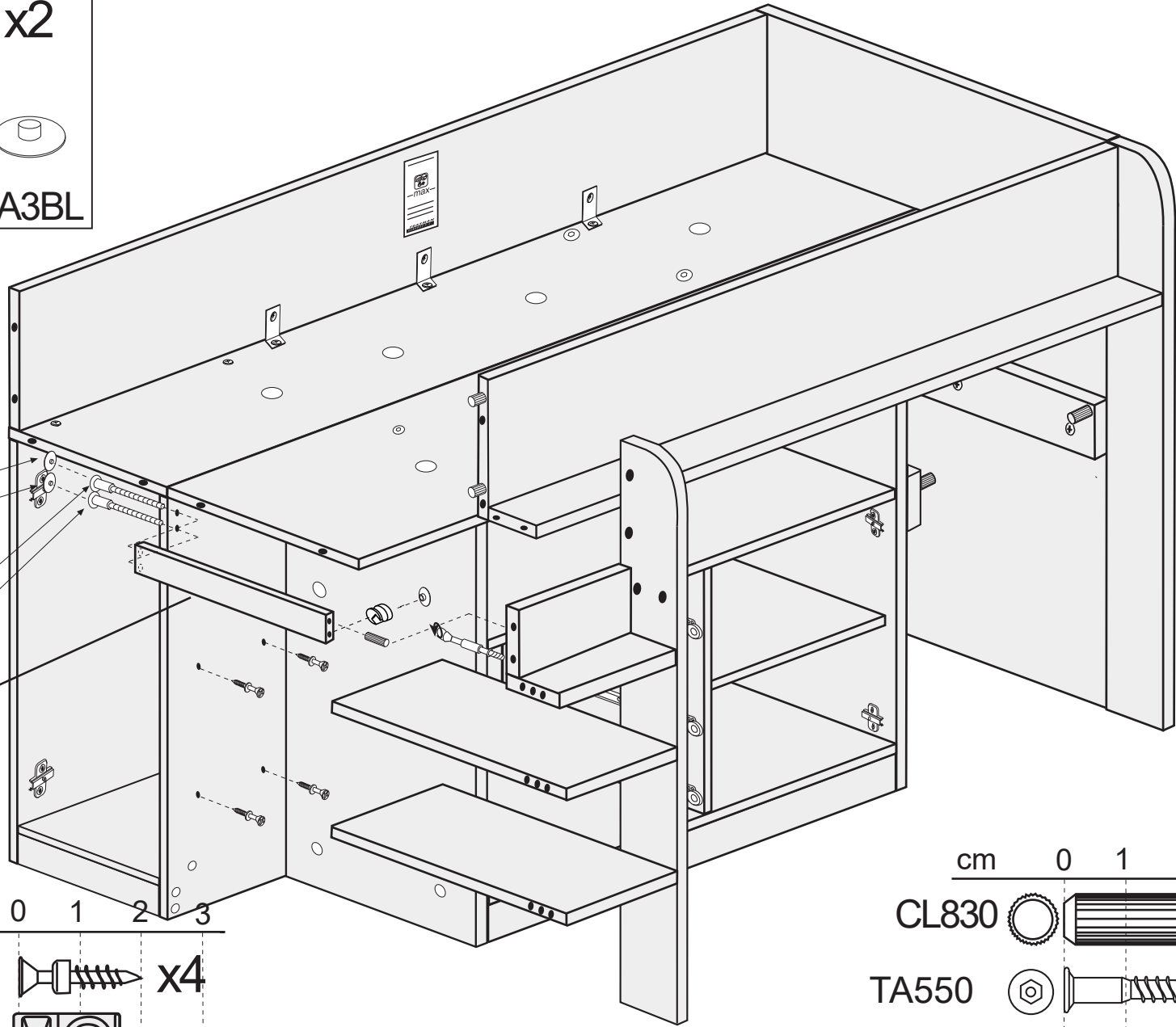

TA3BL
TA3BL
TA550
TA550

601012
601712

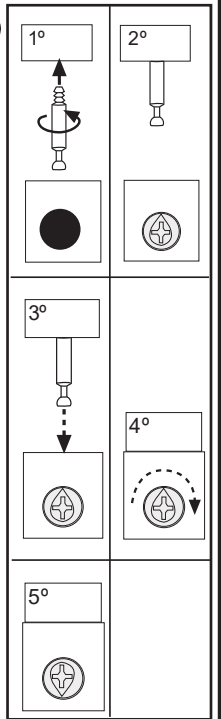

cm 0 1 2 3

- TCK0311 x4
- EX25 x1

cm 0 1 2 3 4 5 6

- CL830 x1
- TA550 x2
- PE845 x1

20b

cm 0 1 2
TP4016  x2

x4



TA4AL
TA4PC

x2





E2136

x2

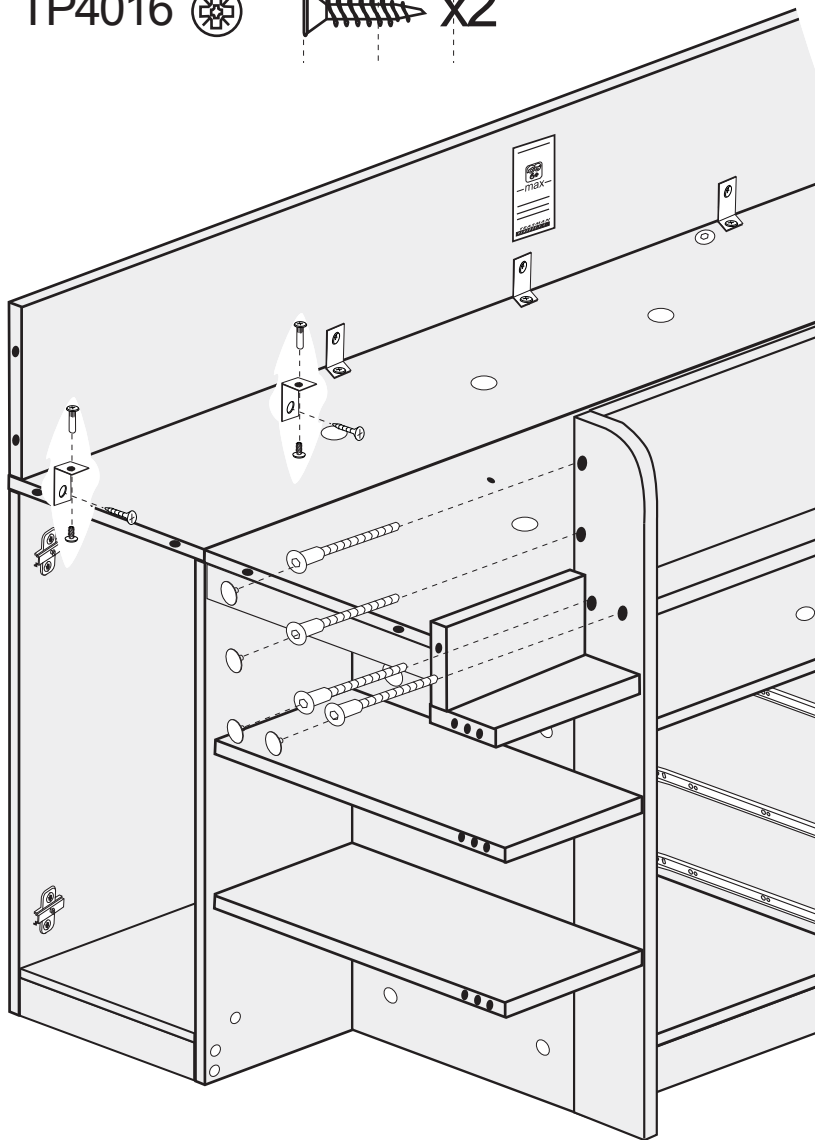

TUM4



cm 0 1 2 3 4 5 6
TA760  x4

21b

x1

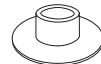



T8AL
T8PC

x1

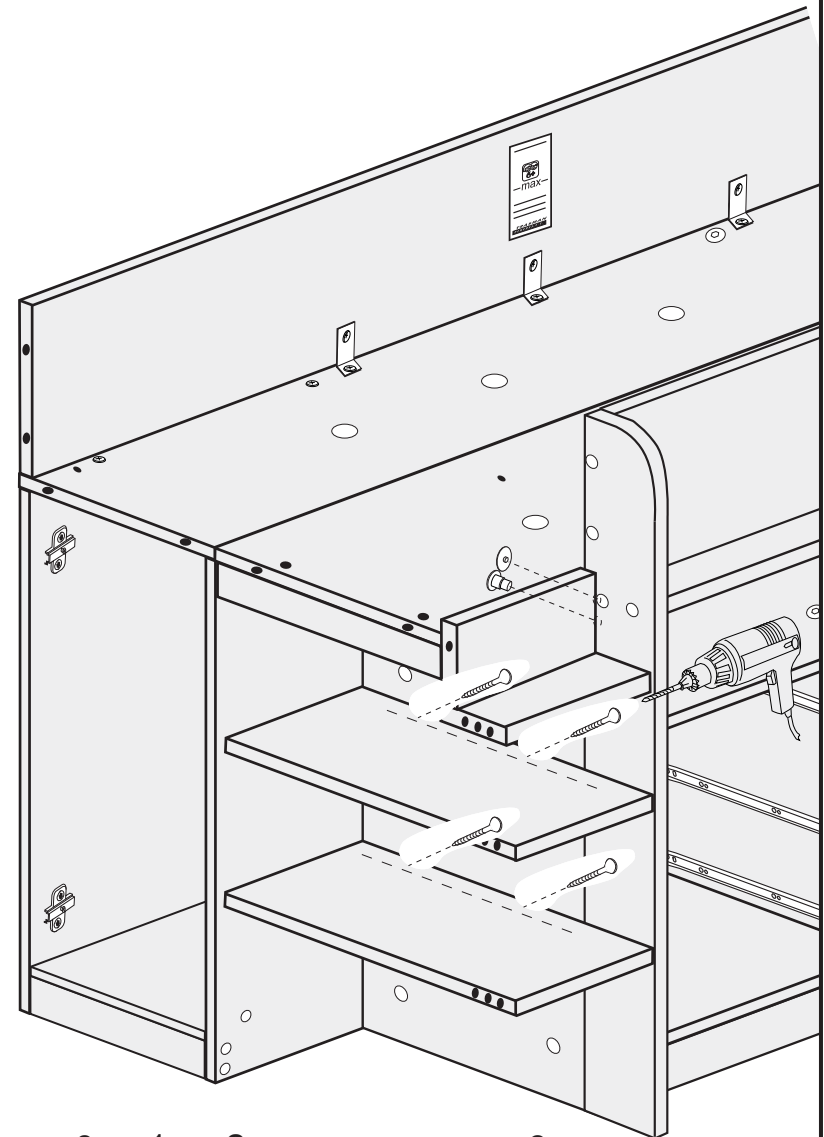

T5AL
T5PC



cm 0 1 2 3 4 5 6
TP3540  x4

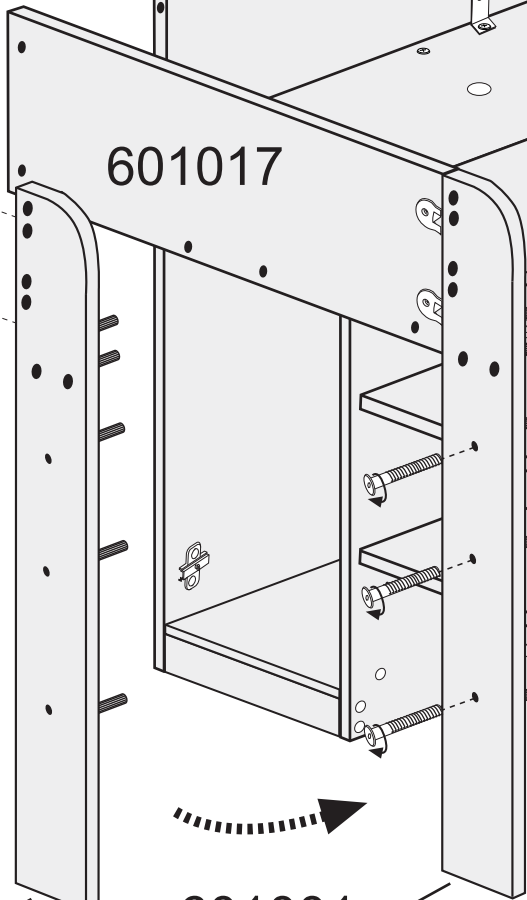
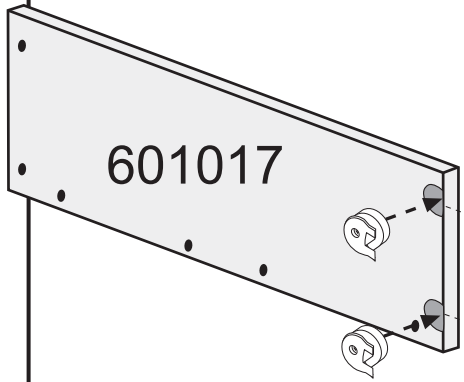
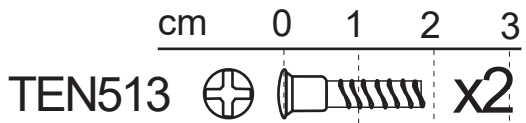

601001
601701



601001
601701

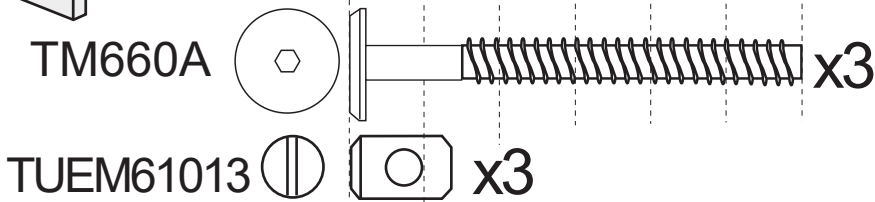
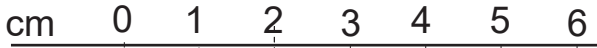

x6



TA4BL

23b

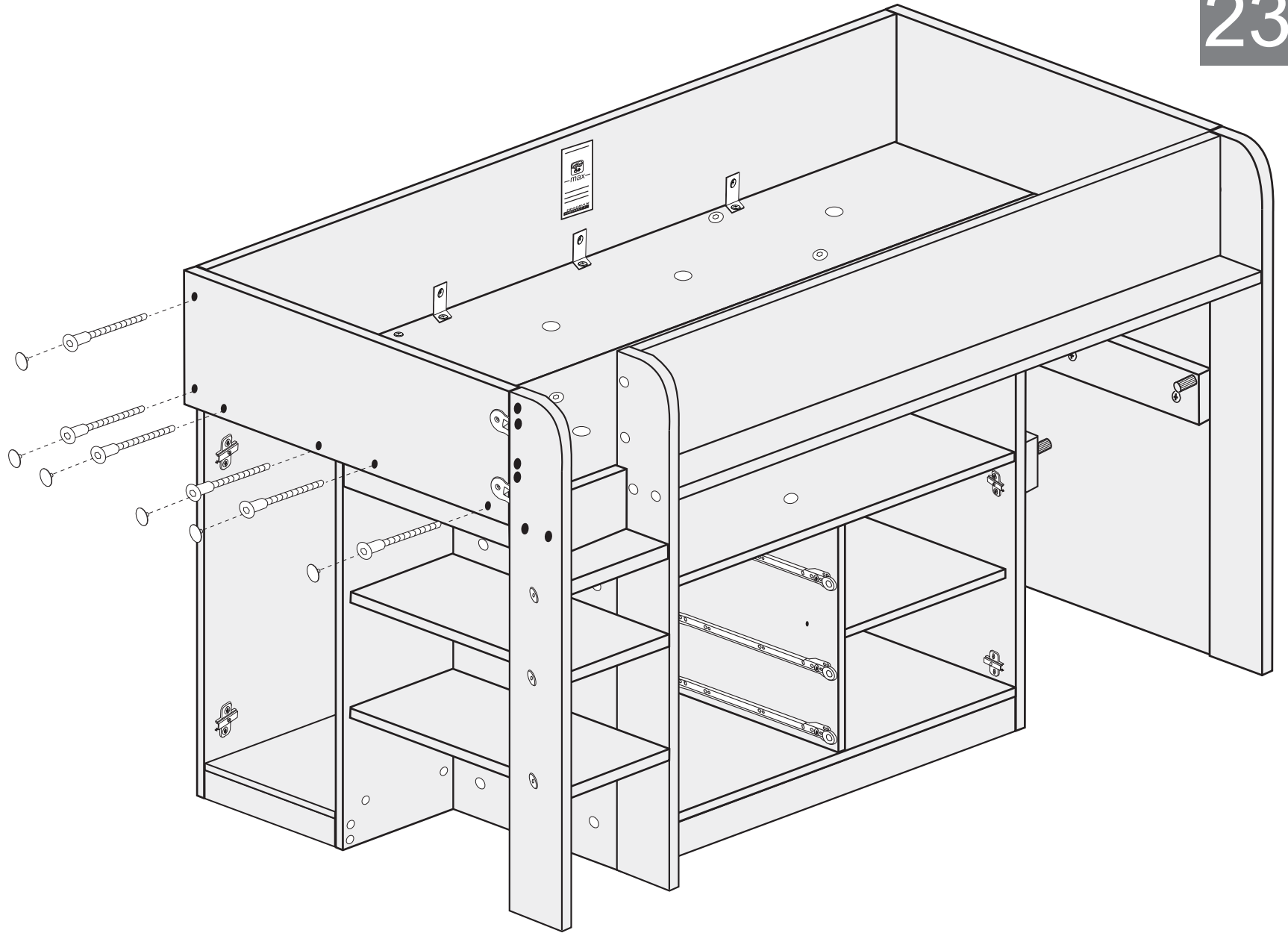

cm 0 1 2 3 4 5 6

TA760   x6

24b

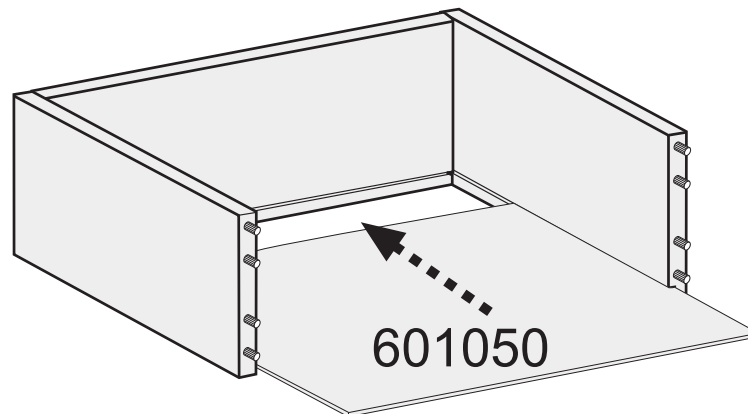
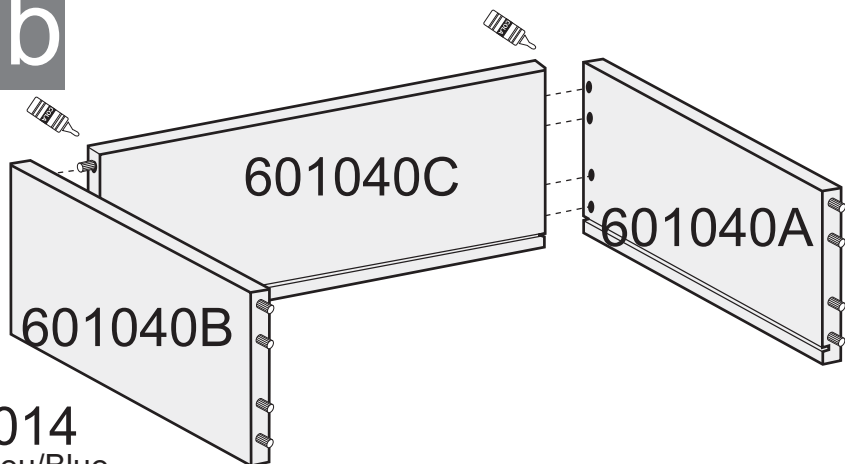

- 601014**
Azul/Bleu/Blue
- 601114**
Verde/Vert/Green
- 601214**
Fucsia/Fuchsia
- 601314**
Grafito/Graphite
- 601414**
Tornasol/Tourne
sol/Sunflower
- 601514**
Rojo/Rouge/Red
- 601614**
Molina
- 601714**
Cascina

x3

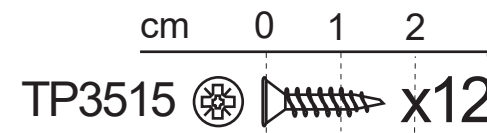
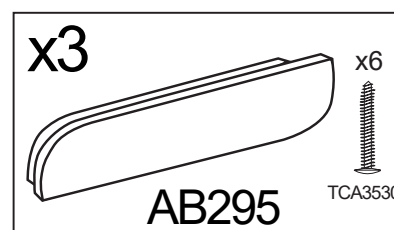
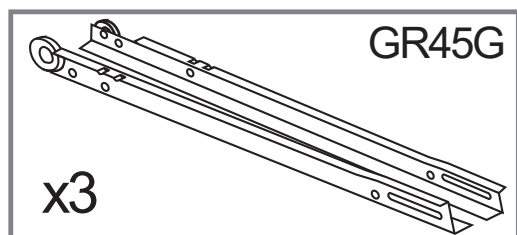
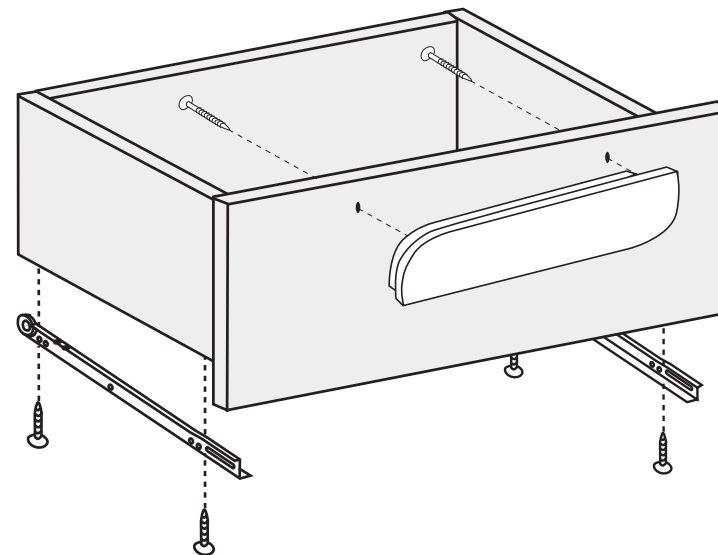
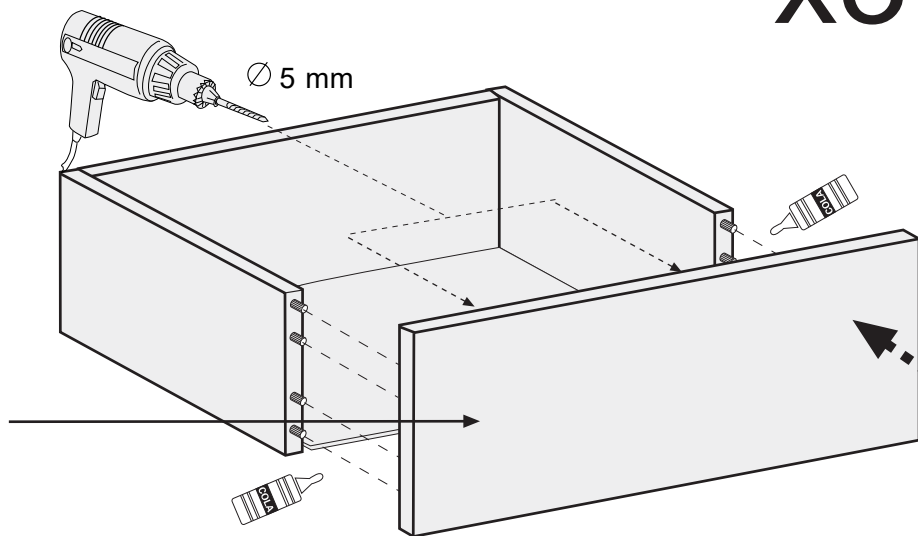

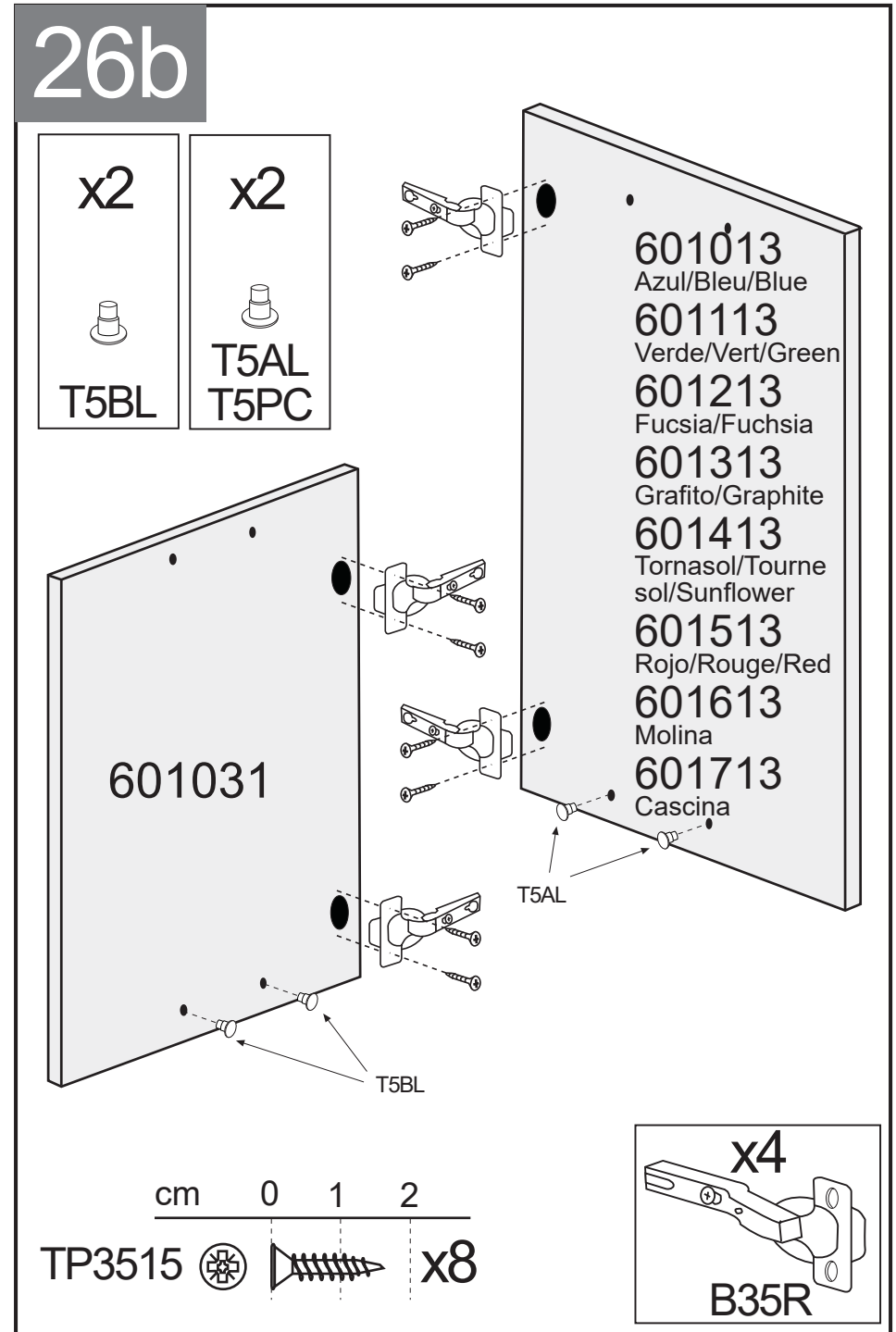
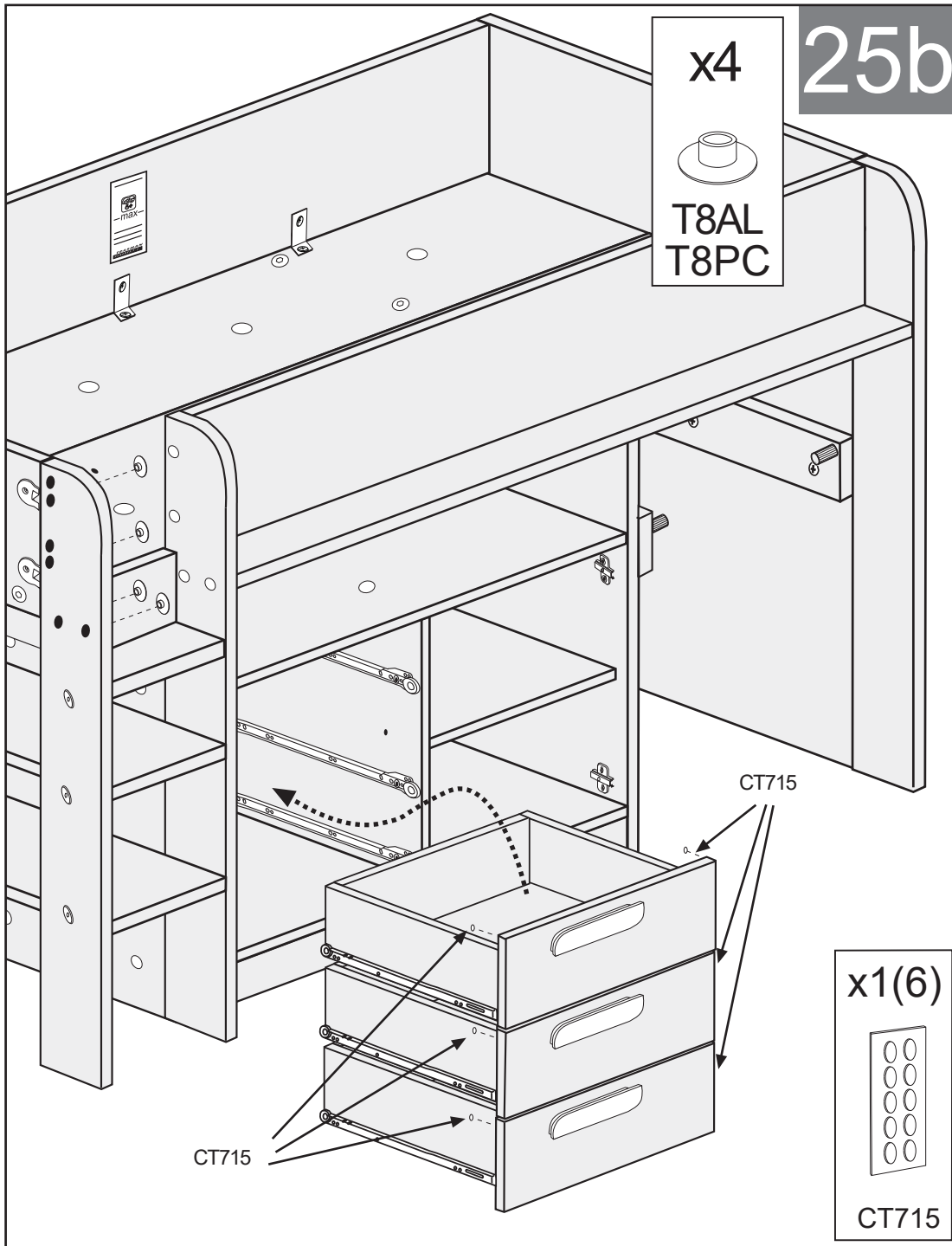

27b 28b

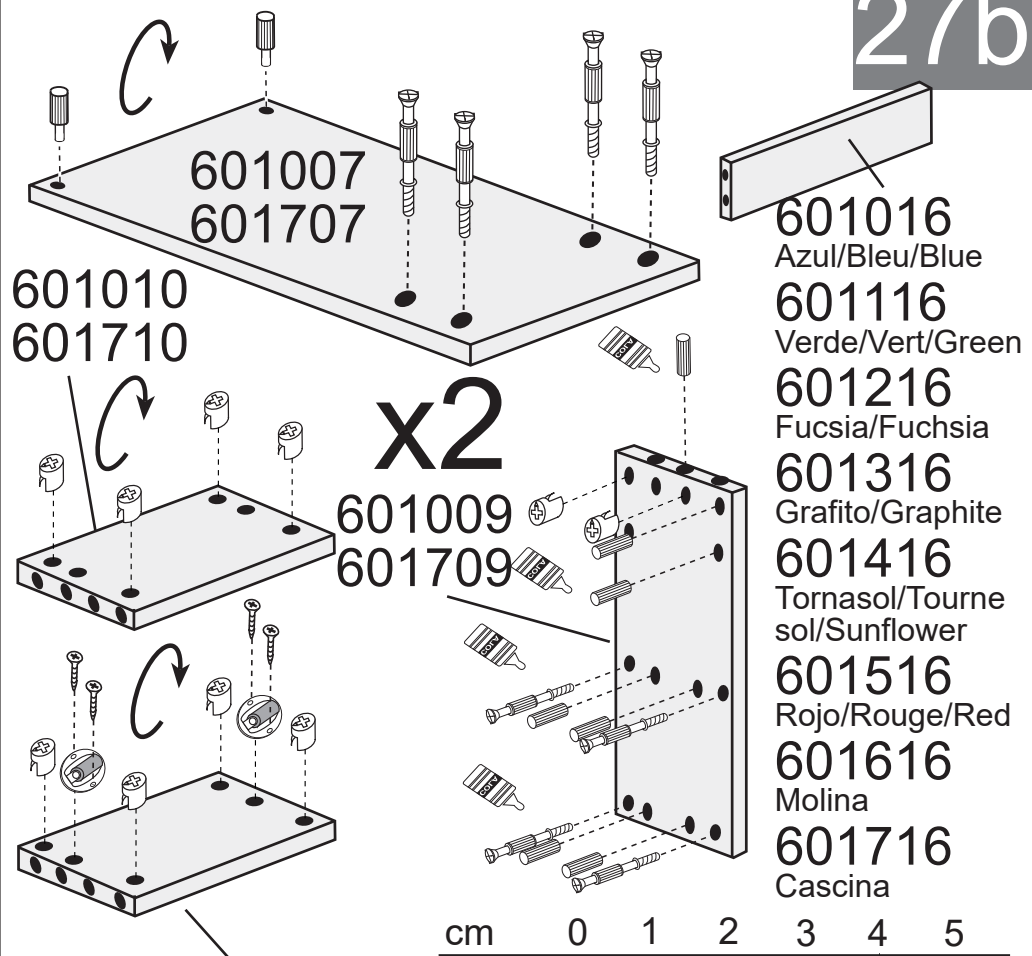

- 601010
601710
- 601009
601709
- 601016
Azul/Bleu/Blue
- 601116
Verde/Vert/Green
- 601216
Fucsia/Fuchsia
- 601316
Grafito/Graphite
- 601416
Tornasol/Tourne
sol/Sunflower
- 601516
Rojo/Rouge/Red
- 601616
Molina
- 601716
Cascina
- cm 0 1 2 3 4 5
- CL830 x14
- PE845 x12
- EX25 x12
- TP2516 x4
- x2** **RTD20**
- x2** **CT8B**

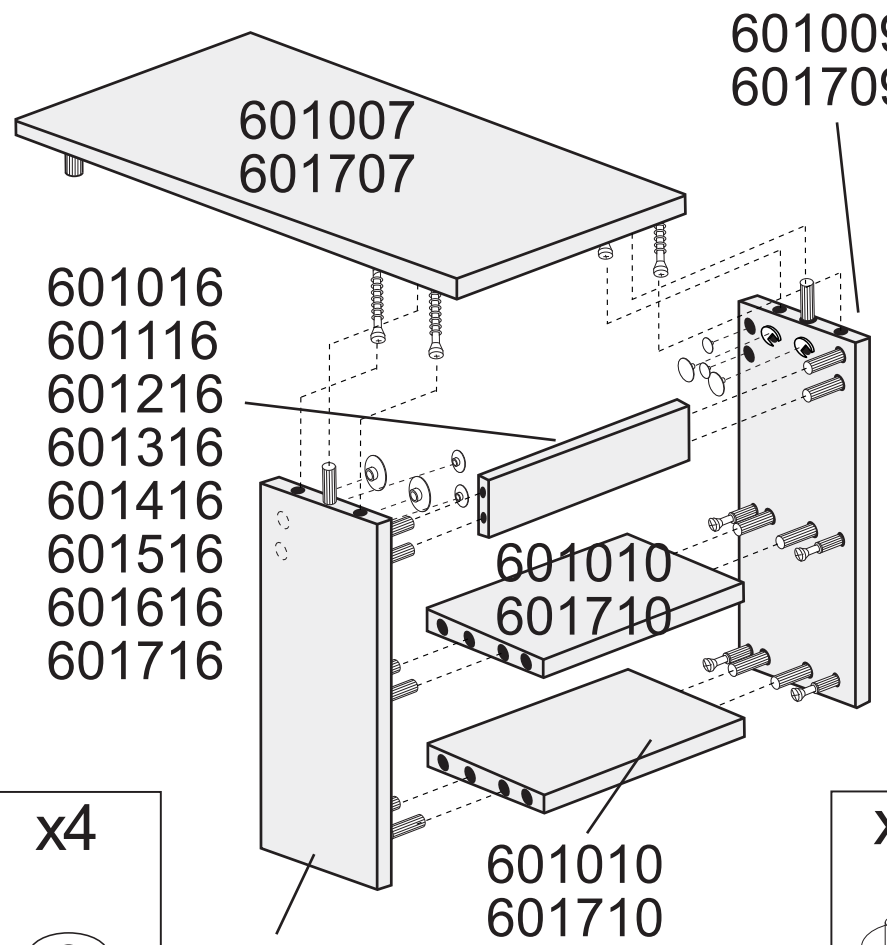

- 601016
- 601116
- 601216
- 601316
- 601416
- 601516
- 601616
- 601716
- x4** **TE17AL**
TE17PC
- 601009
601709
- 601010
601710
- x4** **T8AL**
T8PC

x6

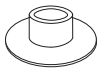

T8AL
T8PC

x1(4)

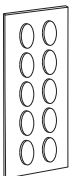

CT715

- 601013
- 601113
- 601213
- 601313
- 601413
- 601513
- 601613
- 601713

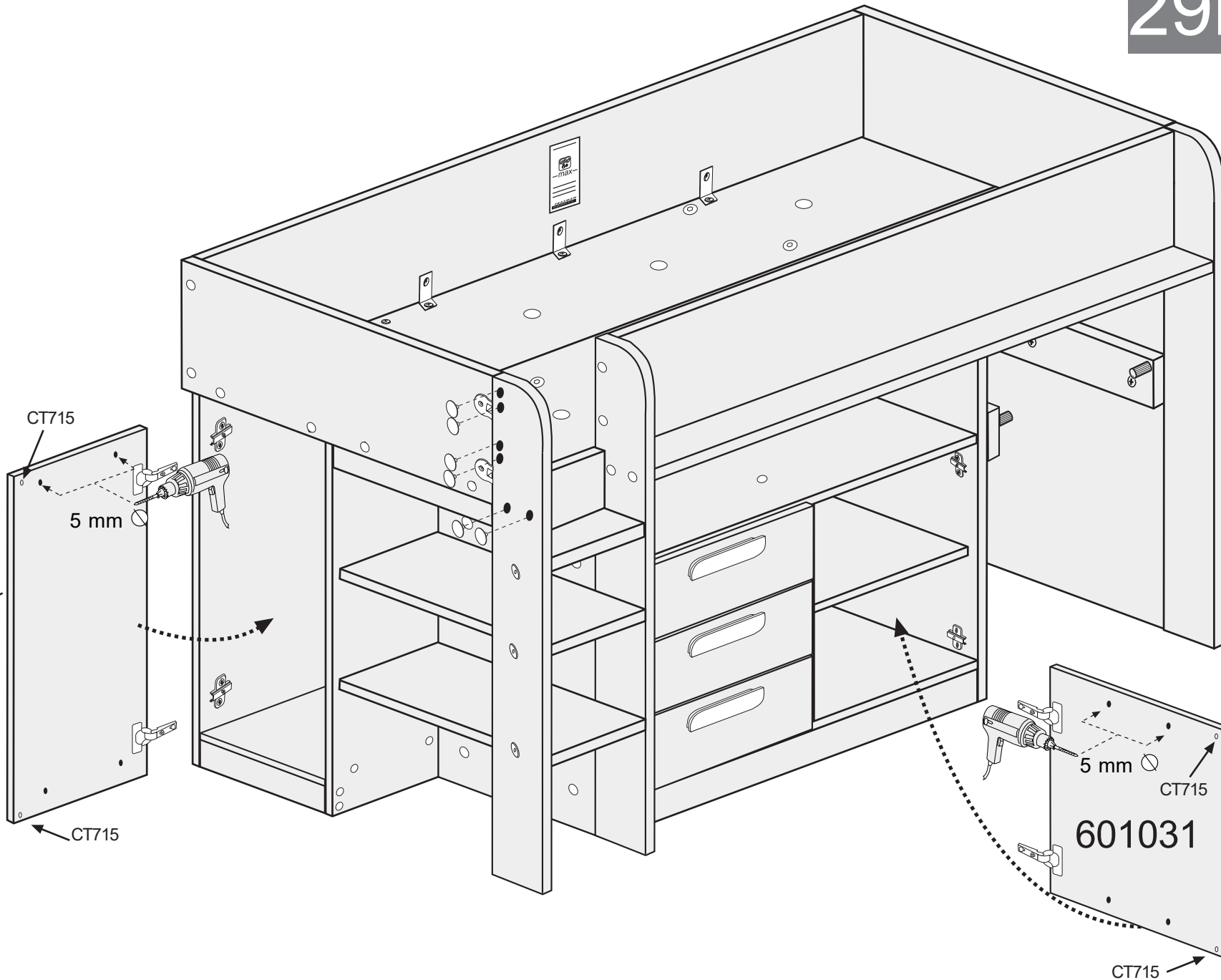

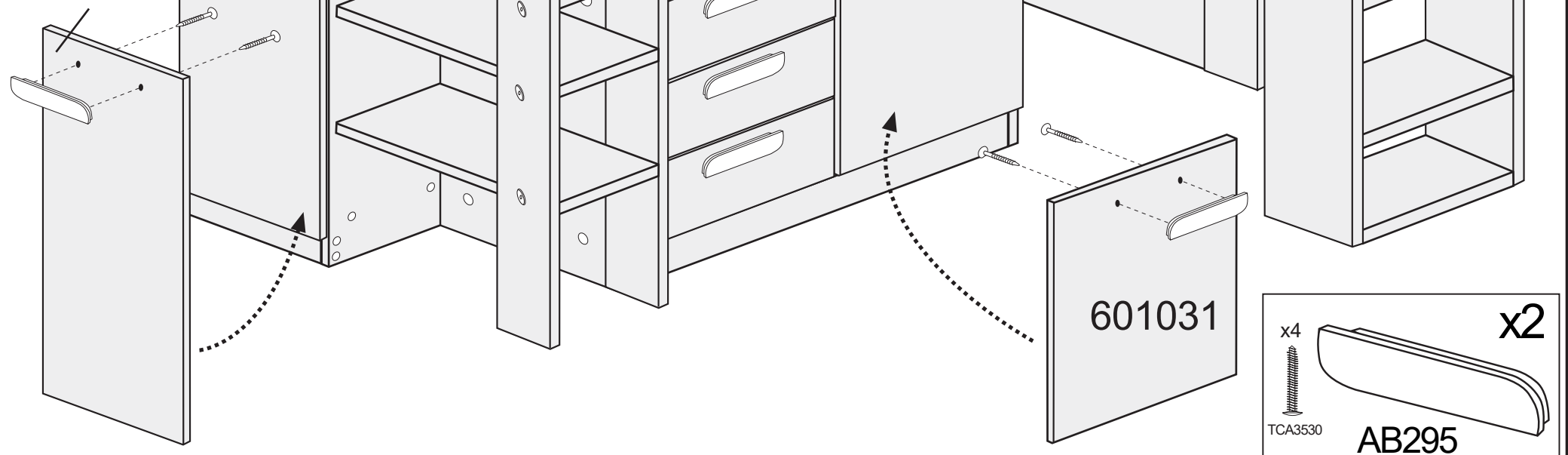

30b

- 601013
- 601113
- 601213
- 601313
- 601413
- 601513
- 601613
- 601713



31b

cm 0 1 2 3 4

TP3515  x4
TP3535  x4

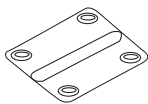
x2

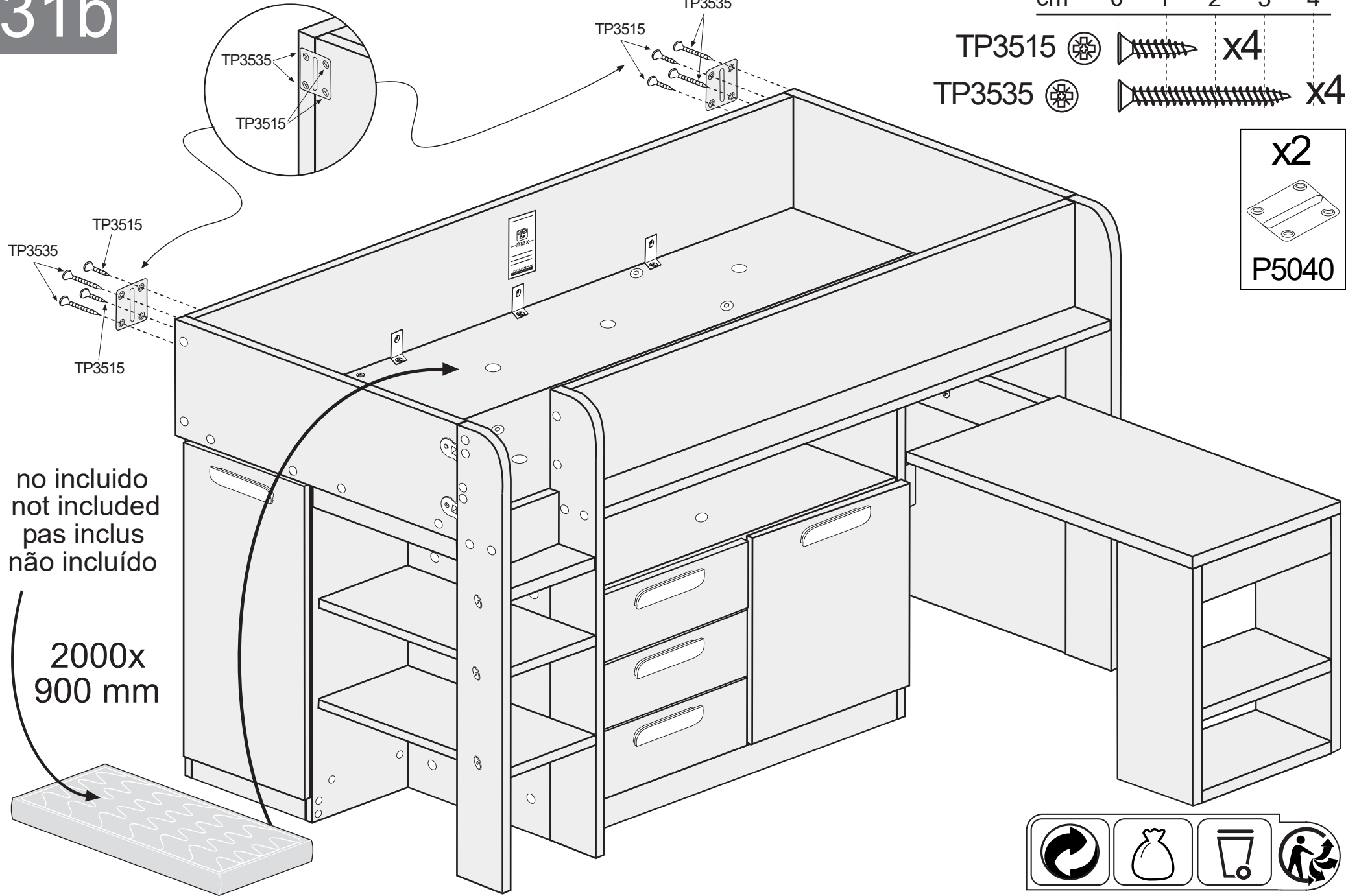
P5040

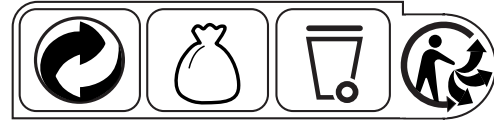

no incluido
not included
pas inclus
não incluído

2000x
900 mm



MANUAL DE MONTAJE
 NOTICE DE MONTAGE
 ASSEMBLY MANUAL
 MANUALE PER IL MONTAGGIO
 MONTAGEANLEITUNG
 MANUAL DE MONTAGEM
 INSTRUKCJE MONTAŻOWE

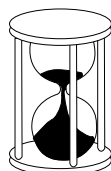
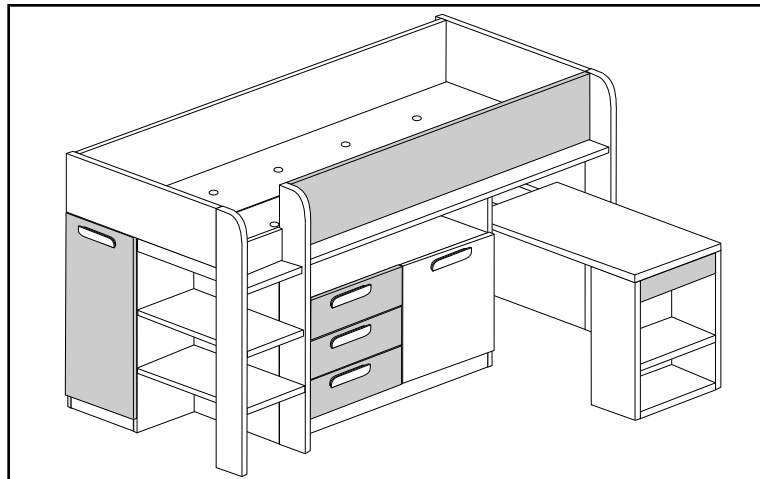

≈ 3h



x2

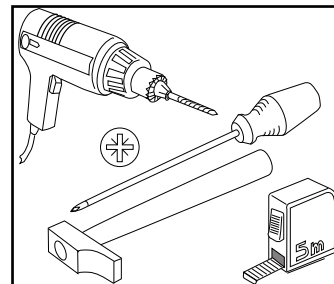

ANTES DE EMPEZAR
 CONSULTE LOS CONSEJOS
 PARA EL MONTAJE.

AVANT DE COMMENCER
 CONSULTEZ LES
 INSTRUCTIONS DE MONTAGE.

BEFORE STARTING REFER TO
 THE ASSEMBLY ADVICE.

PRIMA DI INIZIARE LEGGERE
 I CONIGLI PER IL MONTAGGIO.

VOR DEM BEGINN EMPFIEHLT
 ES SICH AUFMERKSAM DIE
 HINWEISE ZUR MONTAGE ZU
 LESEN.

ANTES DE COMEÇAR
 CONSULTE OS CONSELHOS
 PARA A MONTAGEM .

ZANIM PRZYSTAPIMY DO
 MONTAŻU , PROSIMY
 ZAPOZNAĆ SIĘ Z
 NASTĘPUJACYMI
 WSKAZÓWKAMI.

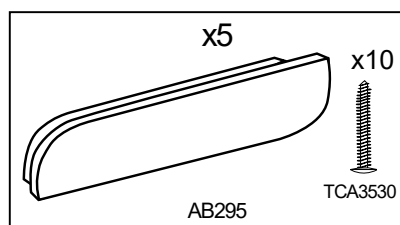
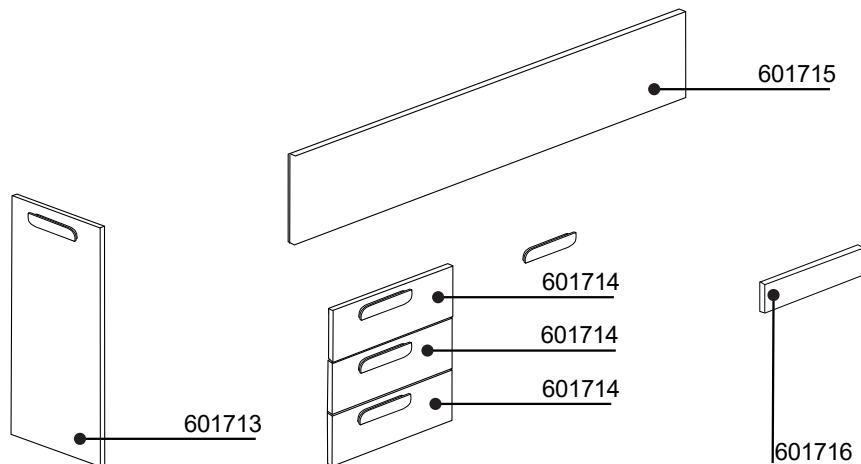

ESPAÑOL

CONSEJOS PARA EL MONTAJE:

- 1-ESTUDIE ATENTAMENTE EL MANUAL DE MONTAJE.
- 2-LOCALICE LAS PIEZAS QUE CONSTITUYEN SU MUEBLE.
- 3-REUNA Y CONTROLE LOS HERRAJES SUMINISTRADOS.
- 4-EQUIPESE CON LAS HERRAMIENTAS NECESARIAS.
- 5-PREPARE UNA ZONA DE MONTAJE.

CONSEJOS PARA EL MANTENIMIENTO:

- 1-QUITAR EL POLVO CUIDADOSAMENTE.
- 2-HUMEDECER UN PAÑO SUAVE Y LIMPIO CON AGUA LIGERAMENTE ENJABONADA.

NO FUERCE NUNCA EN LAS UNIONES APRIETE LOS TORNILLOS DESPUES DE CIERTO TIEMPO DE UTILIZACION.
CONSERVE SU MANUAL DE MONTAJE.SI FALTARA UNA PIEZA SERIA LA MANERA MAS FACIL DE COMUNICARLO A LA TIENDA.

NO USE NUNCA PRODUCTOS ABRASIVOS TALES COMO:
LANA DE ACERO , LIJAS,DISOLVENTES,ETC.
NO MOJAR NI SOMETER A GRANDES HUMEDADES AL MUEBLE.

FRANCAIS

INSTRUCTIONS DE MONTAGE:

- 1-LISEZ ATTENTIVEMENT LA NOTICE DE MONTAGE.
- 2-REPEREZ LES PIECES QUI COMPOSENT VOTRE MEUBLE.
- 3-REGROUPEZ ET VERIFIEZ LES FERRURES FOURNIES.
- 4-DOTEZ-VOUS DES OUTILS NECESSAIRES.
- 5-PREPAREZ UN ESPACE DE MONTAGE.

CONSEILS D'ENTRETIEN:

- 1-ENLEVEZ SOIGNEUSEMENT LA POUSSIERE.
- 2-HUMIDIFIEZ UN CHIFFON DOUX ET PROPRE AVEC DE L'EAU LEGEREMENT SAVONNEUSE.

NE FORCEZ JAMAIS LES RACCORDS. RESSERREZ LES VIS APRES UN CERTAIN TEMPS D'UTILISATION.
CONSERVEZ LA NOTICE DE MONTAGE.EN CAS DE PIECE MANQUANTE , CE SERA LE MEILLEUR MOYEN D'EN INFORMER LE MAGASIN.

N'UTILISEZ JAMAIS DES PRODUITS ABRASIFS COMME DE LA LAINE D'ACIER, DU PAPIER DE VERRE, DES SOLVANTS, ETC.
NE MOUILLEZ PAS LE MEUBLE ET EVITEZ TOUTE EXPOSITION A UNE HUMIDITE IMPORTANTE.

DEUTSCH

HINWEISE ZUR MONTAGE:

- 1- LESEN SIE AUFMERKSAM DIE MONTAGEANLEITUNG DURCH.
- 2- LOKALISIEREN SIE DIE ZUM MÖBEL GEHÖRENDE TEILE.
- 3- KONTROLLIEREN SIE DIE MITGELIEFERTEN WERKZEUGE.
- 4- RÜSTEN SIE SICH MIT DEN ZUSÄTZLICH BENÖTIGTEN WERKZEUGEN AUS.
- 5- BEREITEN SIE EINEN PLATZ FÜR DIE MONTAGE VOR.

HINWEISE ZUR PFLEGE:

- 1- ENTFERNEN SIE UMSICHTIG DEN ANGESAMMELTEN STAUB.
- 2- VERWENDEN SIE EIN WEICHES UND SAUBERES TUCH UND SCHWACHE SEIFENLAUGE.

FORCIEREN SIE NIEMALS DIE VERBINDUNGEN. ZIEHEN SIE DIE SCHRAUBEN NACH EINER BESTIMMTEN NUTZUNGSZEIT NACH.
BEWAHREN SIE DIE MONTAGEANLEITUNG AUF. SOLLTE EIN TEIL FEHLEN IST SIE VON GROSSER WICHTIGKEIT BEI DER NACHBESTELLUNG IM LADEN.

VERWENDEN SIE NIEMALS SCHEUERENDE PRODUKTE WIE STAHLWOLLE, SCHMIRGELPAPIER, LÖSUNGSMITTEL UND DERGL.
WASSER UND HOHE FEUCHTIGKEIT SIND SCHÄDLICH FÜR DAS MÖBEL

ITALIANO

CONSIGLI PER IL MONTAGGIO:

- 1- STUDIARE ATTENTAMENTE IL MANUALE DI MONTAGGIO.
- 2- INDIVIDUARE LE PARTI CHE COSTITUISCONO IL MOBILE.
- 3- RACCOGLIERE E CONTROLLARE GLI ATTREZZI IN DOTAZIONE.
- 4- PROCURARSI GLI ATTREZZI NECESSARI.
- 5- PREPARARE UNA ZONA PER IL MONTAGGIO.

CONSIGLI PER LA MANUTENZIONE:

- 1- SPOLVERARE ACCURATAMENTE.
- 2- INUMIDIRE UN PANNINO MORBIDO E PULITO CON ACQUA E POCO DETERGENTE.

NON FORZARE MAI LE GIUNTURE. STRINGERE NUOVAMENTE LE VITI DOPO UN CERTO PERIODO D'USO.
CONSERVARE IL MANUALE DI MONTAGGIO: SE MANCASSE UN PEZZO SAREBBE COSÌ PIÙ FACILE COMUNICARLO AL RIVENDITORE.

NON USARE MAI PRODOTTI ABRASIVI COME: SPUGNE ABRASIVE, CARTA VETRATA, SOLVENTI, ECC.
NON BAGNARE NE' SOTTOPORRE IL MOBILE A FORTE UMIDITÀ.

POTUGUES

CONSELHO PARA A MONTAGEM :

- 1 - ESTUDE ATENTAMENTE O MANUAL DE MONTAGEM.
- 2 - LOCALIZE AS PEÇAS QUE CONSTITUEM O SEU MÓVEL.
- 3 - REUNA E CONTROLE AS FERRAGENS FORNECIDAS.
- 4 - EQUIPE-SE COM AS FERRAMENTAS NECESSÁRIAS.
- 5 - PREPARE UMA ZONA DE MONTAGEM.

CONSELHOS PARA A MANUTENÇÃO :

- 1- RETIRAR A POEIRA COM CUIDADO.
- 2- HUMEDECER UM PANO SUAVE E LIMPO COM ÁGUA LIGEIRAMENTE ENSABOADA.

NUNCA FORCE AS UNIÕES. APORTE OS PARAFUSOS DEPOIS DE DETERMINADO TEMPO DE UTILIZAÇÃO..
CONSERVE O SEU MANUAL DE MONTAGEM, SE FALTAR UMA PEÇA SERIA A MANEIRA MAIS FÁCIL DE A COMUNICAR À LOJA.

NUNCA USE PRODUTOS ABRASIVOS TAIS COMO : LÃ DE AÇO, LIXAS, DISSOLVENTES, ETC..
NÃO MOLAR NEM SUBMETTER A GRANDES HUMIDADES, O MÓVEL.

POLSKU

WSKAZÓWKI ODNOŚNIE MONTAŻU:

1. PRZECZYTAĆ UWAGNIE NINIEJSZE ZALECENIA.
2. ZLOKALIZOWAĆ CZĘŚCI SKŁADOWE MEBLA.
3. ZEBRAC WSZYSTKIE ELEMENTY ŁĄCZĄCE.
4. ZAOPATRZYĆ SIĘ W NIEZBEDNE NARZĘDZIA.
5. PRZYGOTOWAĆ ODPOWIEDNIE MIEJSCA NA MONTAŻ.

WSKAZÓWKI ODNOŚNIE KONSERWACJI:

1. ODKURZAC OSTROŻNIE.
2. W TYM CELU ZWILŻYC CZYSTĄ MIEKKĄ SZMATKĘ W SŁABYM ROZTWORZE WODY Z MYDŁEM.

NIE DOCISKAC NA SIŁE ELEMENTÓW ŁĄCZĄCYCH. DOKRECIĆ ŚRUBY PO UPŁYWIE PEWNEGO CZASU.
ZACHOWAĆ INSTRUKCJE MONTAŻOWE; W RAZIE BRAKU JAKIEJS CZĘŚCI, UŁATWIA ONE KONTAKT ZE SPRZEDAWCĄ.

NIE NALEŻY NIGDY UŻYWAĆ ŚRODKÓW SZORUJĄCYCH, TAKICH JAK WELNA STAŁOWA, PAPIER SCIERNY, ROZPUSZCZALNIKI ITP.
NIE MOCZYĆ ANI NIE PODDAWAĆ MEBLA DZIAŁANIU DUŻEJ WILGOTNOŚCI.

ENGLISH

ASSEMBLY ADVICE:

- 1- STUDY THE ASSEMBLY MANUAL CAREFULLY.
- 2- LOCATE THE PARTS THAT COMPRISE YOUR FURNITURE ITEM.
- 3- ORGANISE AND CHECK THE FITTINGS SUPPLIED.
- 4- HAVE THE NECESSARY TOOLS TO HAND.
- 5- PREPARE AN ASSEMBLY AREA.

MAINTENANCE ADVICE:

- 1- REMOVE DUST CAREFULLY.
- 2- MOISTEN A SOFT, CLEAN CLOTH WITH SLIGHTLY SOAPY WATER.

DO NOT FORCE ANY OF THE JOINTS. TIGHTEN THE SCREWS AFTER HAVING USED THE FURNITURE FOR SOME TIME.
KEEP YOUR ASSEMBLY MANUAL. IF ANY PART IS MISSING, IT WILL HELP YOU TO LET THE SHOP KNOW.

NEVER USE ABRASIVE PRODUCTS SUCH AS STEEL WOOL, SANDPAPER, ETC.
DO NOT WET THE FURNITURE OR KEEP IT IN A VERY DAMP PLACE.