

16134



Call Us First!
DO NOT RETURN TO STORE.

For questions on assembly or for general inquiries, you may contact us in the following ways:
Call customer service: **1-877-743-3400**

AVOID THE WAIT!

visit us online at
help.backyardproducts.com

- Submit a help request
- Answers to frequently asked questions
- Live chat with an agent



Did you enjoy building your shed?

JOIN OUR TEAM
AND MAKE UP TO \$1,500/WEEK*

Call a Recruiter Today! 734-365-7000



Flexible schedule



No selling,
just building



Bonus incentives
available

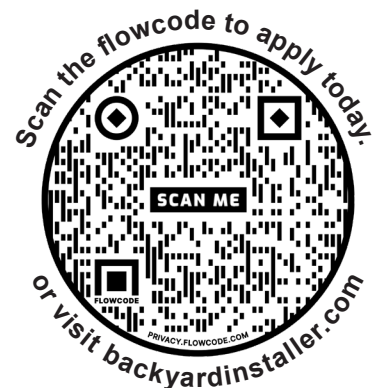

*based on number of completed installations

GABLE 8' x 12' (244 x 366 cm)

ACTUAL FLOOR SIZE IS 96 x 144" (243,8 x 365,8 cm)

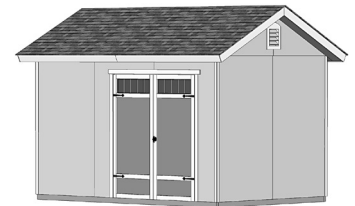
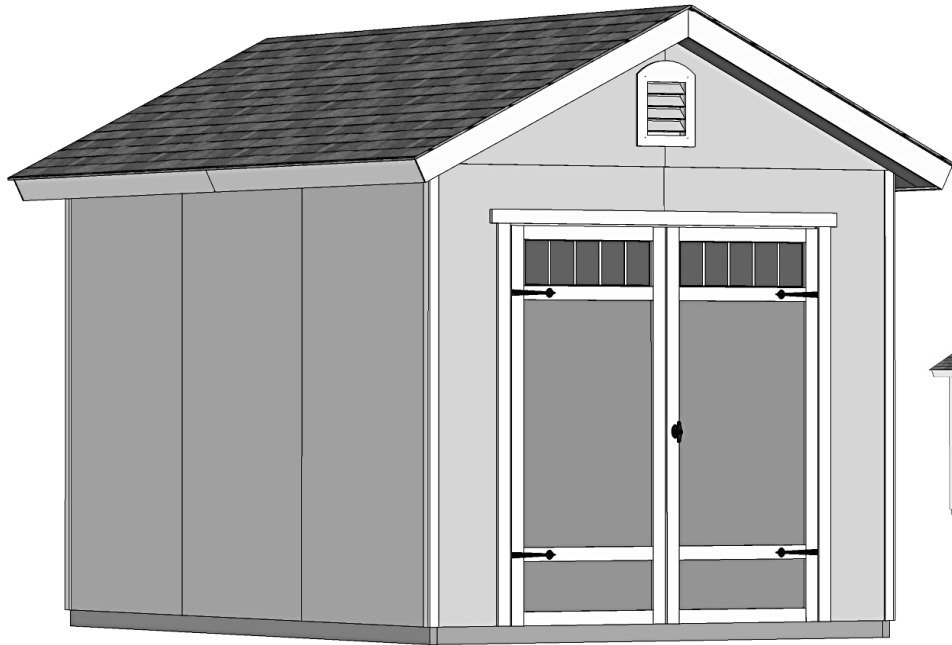
KEEP THIS MANUAL FOR FUTURE REFERENCEOPTIONAL DOOR
LOCATION**IMPORTANT!****READ INSTRUCTIONS THOROUGHLY PRIOR TO BEGINNING ASSEMBLY.****BEFORE YOU BEGIN****• BUILDING RESTRICTIONS AND APPROVALS**

Be sure to check local building department and homeowners association for specific restrictions and/ or requirements before building.

• ENGINEERED DRAWINGS

Contact our Customer Service Team if engineered drawings are needed to pull local permits.

• SURFACE PREPARATION

To ensure proper assembly you must build your shed on a level surface.

Recommended methods and materials to level your shed are listed on page 9.

• CHECK ALL PARTS

Inventory all parts listed on pages 3-5.









• ADDITIONAL MATERIALS





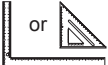

You will need additional materials to complete your shed. See pages 6 for required and optional materials and quantities.

*****CONTACT OUR CUSTOMER SERVICE TEAM
IF ANY PARTS ARE MISSING OR DAMAGED*******- Order form and warranty at back of manual -****Call: 1-877-743-3400 email: customerservice@backyardproductsllc.com**





TOOLS

Required

- Phillips Screwdriver 
- Drill / Driver 
 - 1/8" Drill Bit
 - 1/4" Drill Bit
 - 5/16" Drill Bit
 - 1/2" Drill Bit
 - #2 Phillips Drive Bit
- Hammer 
- Level 
- Pencil 
- Tape Measure 
- Square  or 

- Utility Knife 
 - Shingle Blades 
- Caulk Gun 
- Paint Tools 
- Safety Glasses 
- Hand Saw 
- Ladder 

Optional

- Tool Belt/ Nail Pouch 
- Tin Snips (for drip edge) 
- Chalk Line 
- Nail Gun 
 - gun nails
- Gloves 

Safety! Always use approved safety glasses during assembly.

HELPFUL REMINDER SYMBOLS

Look for these symbols for helpful reminders throughout this manual.



= Assistance Required; two or more people.



= Ensure squareness.



= Important required step or operation.



= Helpful assembly hint.



= Mark part with pencil.



BEGIN = Beginning of steps for assembly or installation.



FINISH = You have finished the assembly or installation.



= Level

ORIENT LUMBER AND TRIM FOR BEST APPEARANCE

Framing lumber is graded for structural strength and not appearance. Exterior trim is graded for one good side.

Always install the material leaving the best edge and best surface visible. Please remember that these blemishes in no way negatively affect the strength or integrity of our product. (See Fig. A, B, C.)

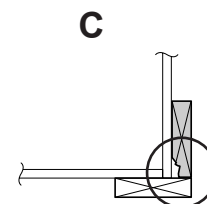
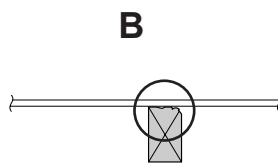
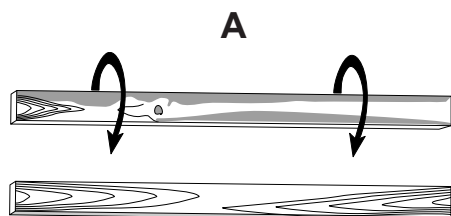

PARTS IDENTIFICATION AND SIZES

Part identification letters are stamped on some parts.



Check these locations for part stamp.

WOOD SIZE CONVERSION CHART

Nominal Board Size	Actual Size
2" x 4".....	1-1/2" x 3-1/2" (3,8 x 8,9 cm)
1" x 4".....	3/4" x 3-1/2" (1,9 x 8,9 cm)
2" x 3".....	1-1/2" x 2-1/2" (3,8 x 6,3 cm)
1" x 3".....	3/4" x 2-1/2" (3,8 x 6,3 cm)

PARTS LIST



INVENTORY YOUR PARTS before you begin.

We suggest sorting parts by the category they are listed in.

WALLS

- x1 **GAA** 1 x 3 x 5" (2,5 x 7,6 x 12,7 cm) Gauge Block for 3/4" (1,9 cm) measurement
- x2 **CQA** 2 x 4 x 4" (5,1 x 10,2 x 10,2 cm)
- x5 **UY** 2 x 4 x 6-1/2" (5,1 x 10,2 x 16,5 cm)
- x1 **RGF** 2 x 3 x 8" (5,1 x 7,6 x 20,3 cm) (Used when window installed.)
- x2 **SP** 2 x 4 x 48" (5,1 x 10,2 x 121,9 cm)
- x4 **HVC** 2 x 4 x 44-3/8" (5,1 x 10,2 x 112,7 cm)
- x1 7/16 x 3-1/4 x 66-3/4" (1,1 x 8,3 x 169,5 cm) OSB
- x2 **AM** 2 x 4 x 67" (5,1 x 10,3 x 170,2 cm)
- x2 **YFA** 2 x 4 x 68-1/2" (5,1 x 10,2 x 174 cm)
- x20 **AI** 2 x 4 x 78-1/2" (5,1 x 10,2 x 199,4 cm)
- x2 **SZ** 2 x 4 x 89" (5,1 x 10,2 x 226,1 cm)
- x4 **TJ** 2 x 4 x 92-5/8" (5,1 x 10,2 x 235,3 cm)
- x6 **TP** 2 x 4 x 96" (5,1 x 10,2 x 243,8 cm)

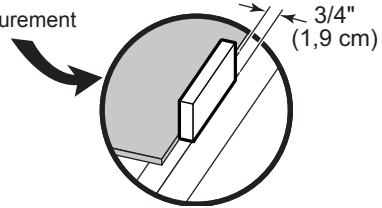

RAFTERS

- x12 6 x 24" (15,2 x 61 cm) OSB OR WOOD GRAIN ⚠
- x12 **CLA** 2 x 4 x 4-7/8" (5,1 x 10,2 x 12,4 cm)
- x2 **GUA** 1 x 3 x 60" (1,6 x 7,6 x 152,4 cm)
- x8 **CMA** 2 x 4 x 61-7/8" (5,1 x 10,2 x 157,2 cm)
- x14 **CNA** 2 x 4 x 61-7/8" (5,1 x 10,2 x 157,2 cm)

TRIM

- x4 3/8 x 1-3/4 x 81-7/8" (1 x 4,4 x 208 cm)
- x4 3/8 x 1-3/4 x 82-1/2" (1 x 4,4 x 209,6 cm)
- x4 3/8 x 7-7/8 x 59-15/16" (1 x 20 x 152,2 cm)
- x2 3/8 x 4-3/4 x 62-7/16" (1 x 12,1 x 158,6 cm)
- x2 3/8 x 4-3/4 x 62-7/16" (1 x 12,1 x 158,6 cm)
- x4 3/8 x 5-7/8 x 73" (1 x 14,9 x 185,3 cm)
- x4 3/8 x 4-3/4 x 80-7/8" (1 x 12,1 x 205,3 cm)

DOOR

- x4 **AH** 19/32 x 2-1/2 x 26-5/8" (1,5 x 6,3 x 67,6 cm)
- x2 **OO** 69" (175,3 cm) Door Stiffener
- x1 **ZJ** 19/32 x 3 x 72" (3,2 x 7,6 x 182,9 cm)

WALL PANELS & DOORS

NOTE: Panel parts are not stamped.

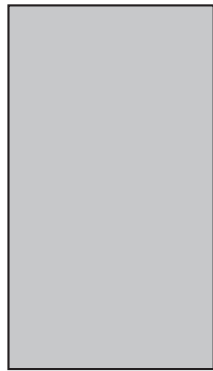

x8
3/8 x 48 x 84"
(1 x 121,9 x 213,4 cm)

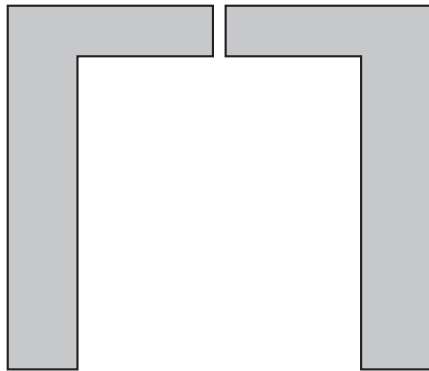

x1

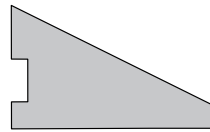

x2

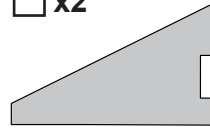

x2

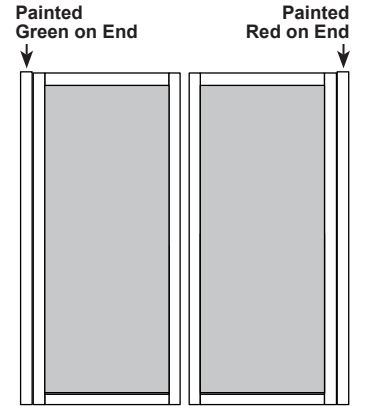

x1
LEFT DOOR

x1
RIGHT DOOR



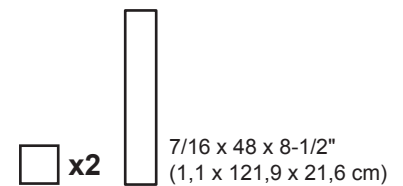
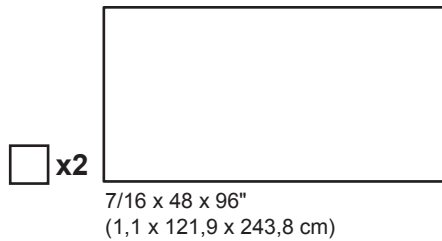
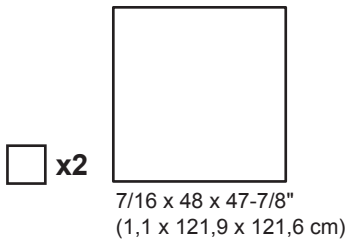
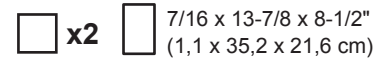
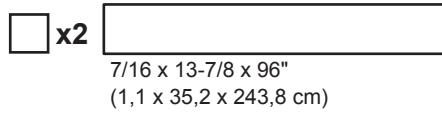
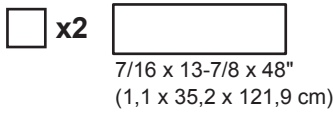

ROOF PANELS

Roof panels are 7/16" (1,1 cm) thick.

NOTE: Panel parts are not stamped.

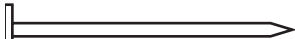
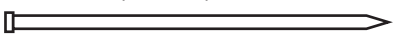





FASTENERS & HARDWARE

- x75  1-1/2" (3,8 cm)
- x225  2" (5,1 cm)
- x170  3" (7,6 cm)
- x24  2" (5,0 cm)
- x52  1-5/8" (4,1 cm)
- x75  3/4" (1,9 cm)

NOTE:

If you are using a nail gun, nails may be used where screws are shown for quicker assembly. Length of nail must match screw length.

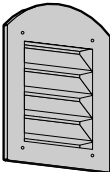
VENT, WINDOW and DOOR HARDWARE



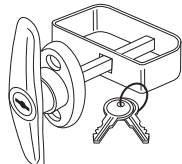

- x4 
- x12  1" (2,5 cm)
- x2 
- x8  #8 x 1" (2,5 cm)
Pan Head Screws

Handle (locking) with Screws



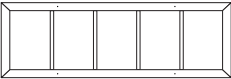

x2  1-1/4" (3,2 cm)

x1

- x2 
Transom Window
- x8  3/4" (1,9 cm)
- x1 
64" Metal Threshold
 3/4" (1,9 cm) x11
Bagged separately / special coating

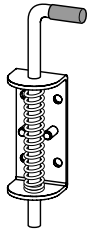
Spring Bolt

x2 

x8  1-1/4 (3,2 cm)
(4 screws in each package)

ADDITIONAL MATERIALS

FOUNDATION OR FLOOR MATERIALS

- This shed does not include any floor or leveling materials. Use our optional floor kit with building instructions and nails included.
- See the FLOOR LEVELING section on page 9 for recommended methods and suggested materials to properly level your floor, as this will vary depending on your specific site.
- If you choose to install your kit on a concrete slab refer to page 7.
- If you choose to build your own wood floor foundation refer to page 8.

REINFORCED WOOD FLOOR FRAME (OPTIONAL)

IMPORTANT! Depending on your specific use you may want to construct a heavy duty floor frame by adding additional floor joists (shown below as shaded). Below is a list of additional materials (not included):

- x3** 2 x 4 x 10' (5 x 10 x 304,8 cm) Treated Lumber
Cut to (3) 2 x 4 x 117" (5 x 10 x 297,2 cm)
- x12** ea. 3" (7,6 cm) Hot Dipped Galvanized Nails

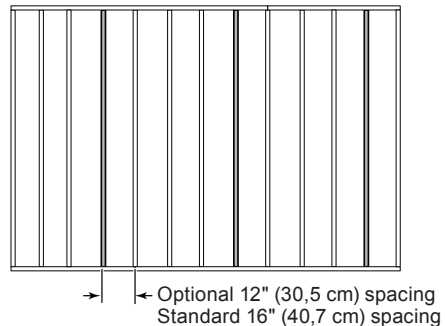

COMPLETING YOUR SHED

You will need these additional materials:

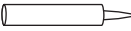
- | | |
|--|---|
| <input type="checkbox"/> 3-TAB SHINGLES 6 Bundles | <input type="checkbox"/> 1" GALVANIZED ROOFING NAILS 3 Lbs
For shingles. |
| <input type="checkbox"/> PAINT FOR SIDING 2 Gallons
Use 100% acrylic latex exterior paint. (2) coats recommended. | <input type="checkbox"/> PAINT FOR TRIM 2 Quarts
Use 100% acrylic latex exterior paint. |
| <input type="checkbox"/> CAULK 3 Tubes
Use acrylic latex exterior caulk that is paintable.  | |

OPTIONAL MATERIALS

- | | |
|---|--|
| <input type="checkbox"/> DRIP EDGE 60 Feet | <input type="checkbox"/> #15 ROOFING FELT
To cover 162 sq. ft. of roof area. |
| | <input type="checkbox"/> 1" GALVANIZED ROOFING NAILS1/4 Lb
For roofing felt. |

REFER TO THE BACK OF THIS MANUAL AND THE MANUFACTURER'S INSTRUCTIONS FOR INSTALLATION OF SHINGLES, DRIP EDGE AND FELT.

CONCRETE FOUNDATION

Your kit contains all materials to construct a wooden floor. If you choose to install your kit on a concrete slab refer to the diagram below.

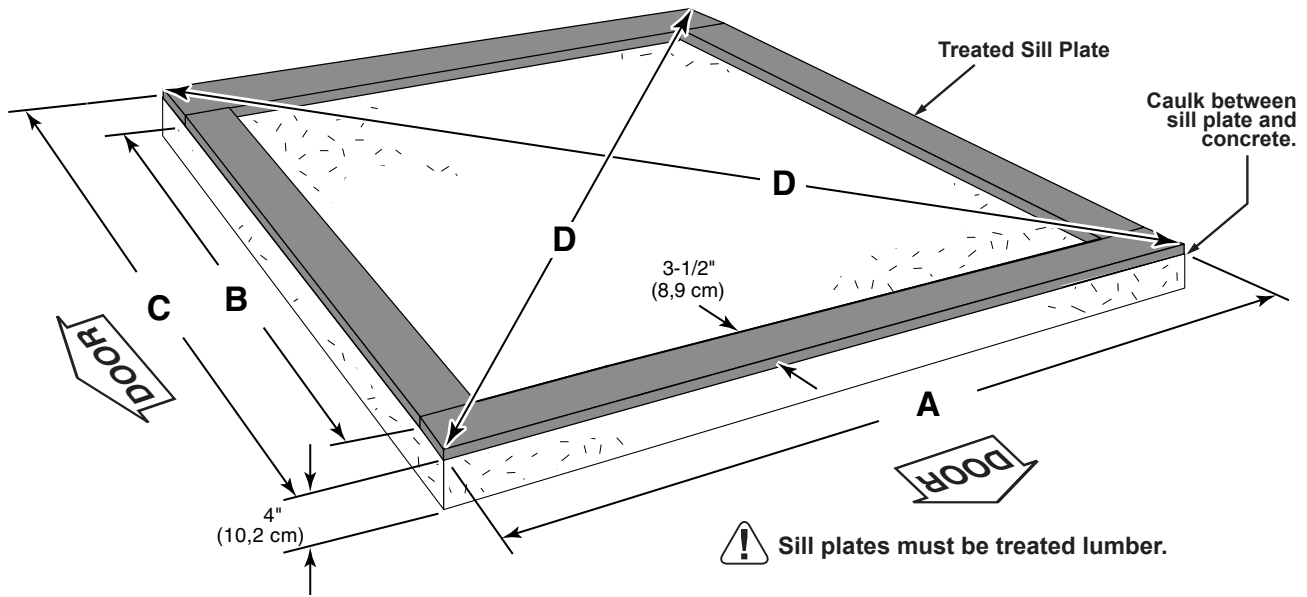

Building Size	Actual Size	A	B	C
8'x 12' (243,8 x 365,8 cm)	96" x 144" (243,8 x 365,8 cm)	96" (243,8 cm)	137" (348 cm)	144" (365,8 cm)

Requires:

- x2** 2 x 4 x 12' (5,1 x 10,2 x 365,8 cm) ⚠ **MUST be treated lumber.**
- x2** 2 x 4 x 8' (5,1 x 10,2 x 244 cm) ⚠ **MUST be treated lumber.**
- x1** Caulk

⚠ Allow new concrete slabs to cure for at least seven (7) days.

- A treated 2 x 4 (5,1 x 10,2 cm) sill plate is required when installing your shed on concrete.
Hint: Purchase full length treated lumber.
- Use a high quality exterior grade caulk beneath all sill plates.
- Fasten 2 x 4 (5,1 x 10,2 cm) sill plates to slab using approved concrete anchors (**fasteners not included**).
- Check local code for concrete foundation requirements.

NOTES

BUILD YOUR OWN WOOD FLOOR OPTION

(Materials not included.)

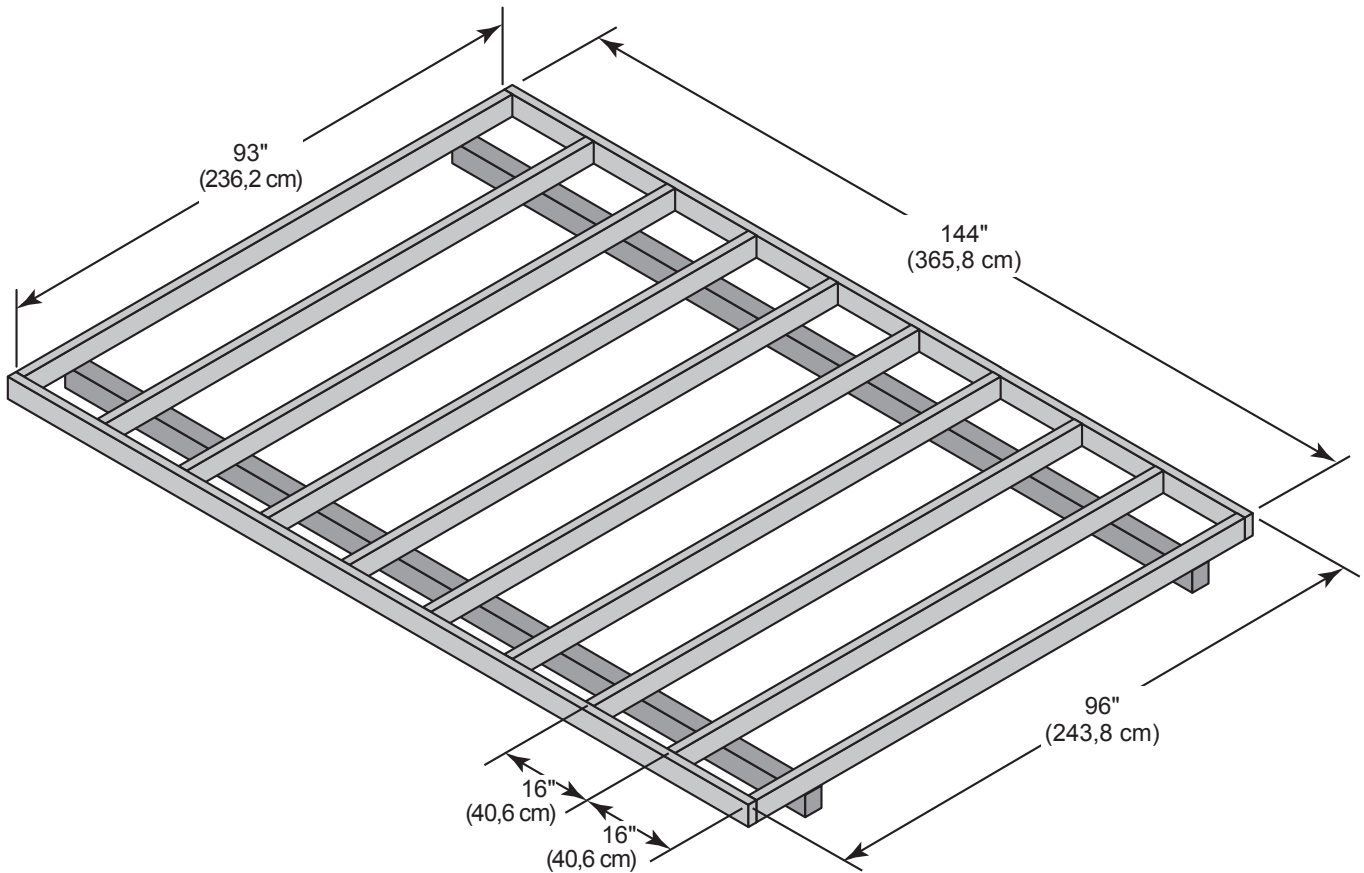

MATERIAL REQUIRED

- x2** 2 x 4 x 12' (5,1 x 10,2 x 365,8 cm) **MUST be treated lumber**
- x10** 2 x 4 x 8' (5,1 x 10,2 x 243,8 cm) **MUST be treated lumber**
- x2** 4 x 4 x 12' (10,2 x 10,2 x 365,8 cm) **MUST be treated lumber**

- x3** 5/8" x 48" x 96" (1,6 x 121,9 x 243,8 cm)

- x1** 2" (5,1 cm) **1 lb. of 2" (5,1 cm) Hot Dipped Galvanized Box-Type Nails**

- x40** 3" (7,6 cm) **40 Nails - 3" (7,6 cm) Hot Dipped Galvanized Box-Type Nails**

- x40** 3" (7,6 cm) **Screws for Frame to 4"x 4"**
Minimum 3" screws / exterior grade.

OPTIONAL WOOD FRAME FLOOR LEVELING OPTIONS

There are multiple ways to level your floor frame. Our recommended leveling method is shown below.
Leveling materials are not included in this kit.

PREFERRED METHOD - 4 x 4 TREATED RUNNERS (Typical for 8' x 12' Kit)

Runners are generally 12" (30,5 cm) from ends of floor frame and under seams.

Measurements to centers of 4 x 4's.

- 3" Screws angled into 4 x t4.
- (2) at each point frame and 4x4 touch.

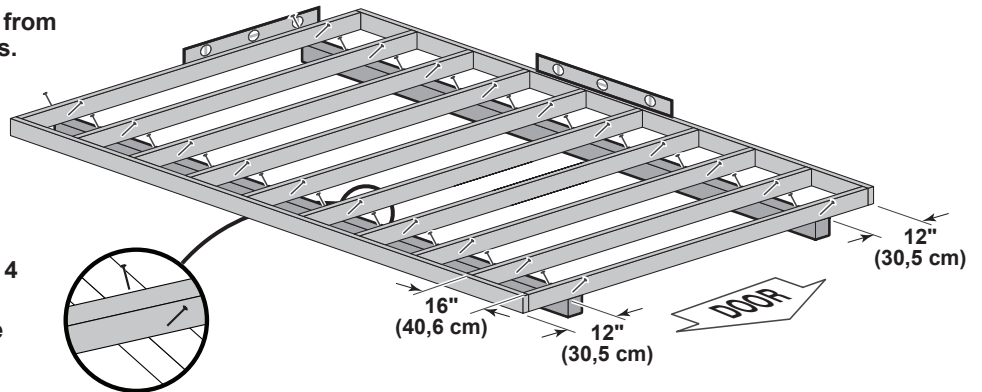

! FLOOR FRAME NOT INCLUDED

MATERIAL REQUIRED

8' x 12' x2 4 x 4 x 12' (10,2 x 10,2 x 365,8 cm) Treated Lumber

Fasteners for Frame to 4 x 4.
(3" Screws shown as one option.)
Minimum 3" screws / exterior grade.

x40  3" (7,6 cm)

! Use only wood treated for ground contact and fasteners approved for use with treated wood.

! Always support frame seams.

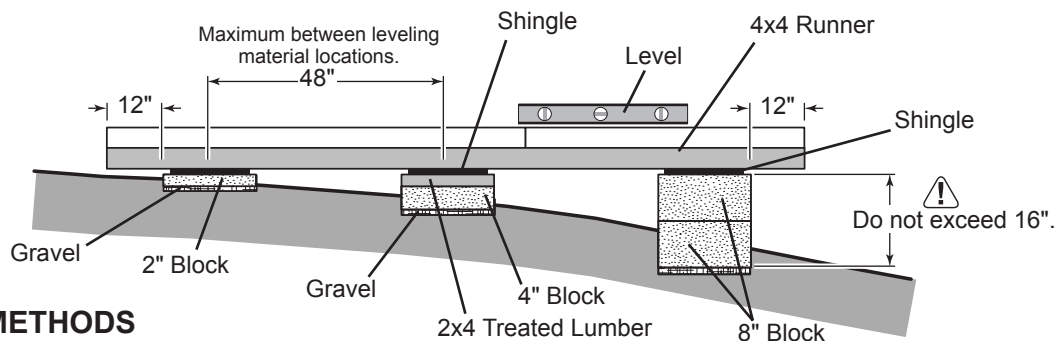

LEVELING METHODS

- Level under 4x4 runners only.
- Locate leveling material 12" from ends of runners and no more than 48" apart.
- Asphalt shingles should be used between 4x4 runners and blocks or treated lumber. Never use shingles in direct contact with ground.
- For best results and aiding in water drainage use gravel under each concrete block.

LEVELING MATERIALS

- Gravel
- Solid Masonry Blocks in 1", 2", 4" or 8" thickness
- 2x4 Treated Lumber
- Asphalt Shingles

! Leveling higher than 16" not recommended.

CONCRETE

- If you are building your shed on a concrete foundation see the following page.

STOP!



LEVEL AND SQUARE FLOOR FRAME



STOP!

Before attaching floor decking, it is important to level and square the floor frame.
A level and square floor frame is required to correctly construct your shed.

✓ **BEGIN**

- 1 See page 9 for the preferred floor leveling method.
- 2 Use a level to ensure the frame is level before installing floor panels.
- 3 Check for frame squareness by measuring diagonally across corners. If the measurements are the same, the frame is square. The diagonal measurement will be approximately 173-1/16" (439,6 cm).
- 4 When the frame is level and square, secure one side of frame to the 4x4 runners using one fastener at ends of each runner. Move to the opposite end of the frame. Secure the frame to 4x4 runners with one fastener at ends of each runner, making sure the frame remains square (**Fig. A**).



FINISH

After the floor frame is level and square, fasten the frame to the 4x4 runners at each point where the frame contacts the 4x4 runners.

First, secure at ends with one fastener.

Fig. A

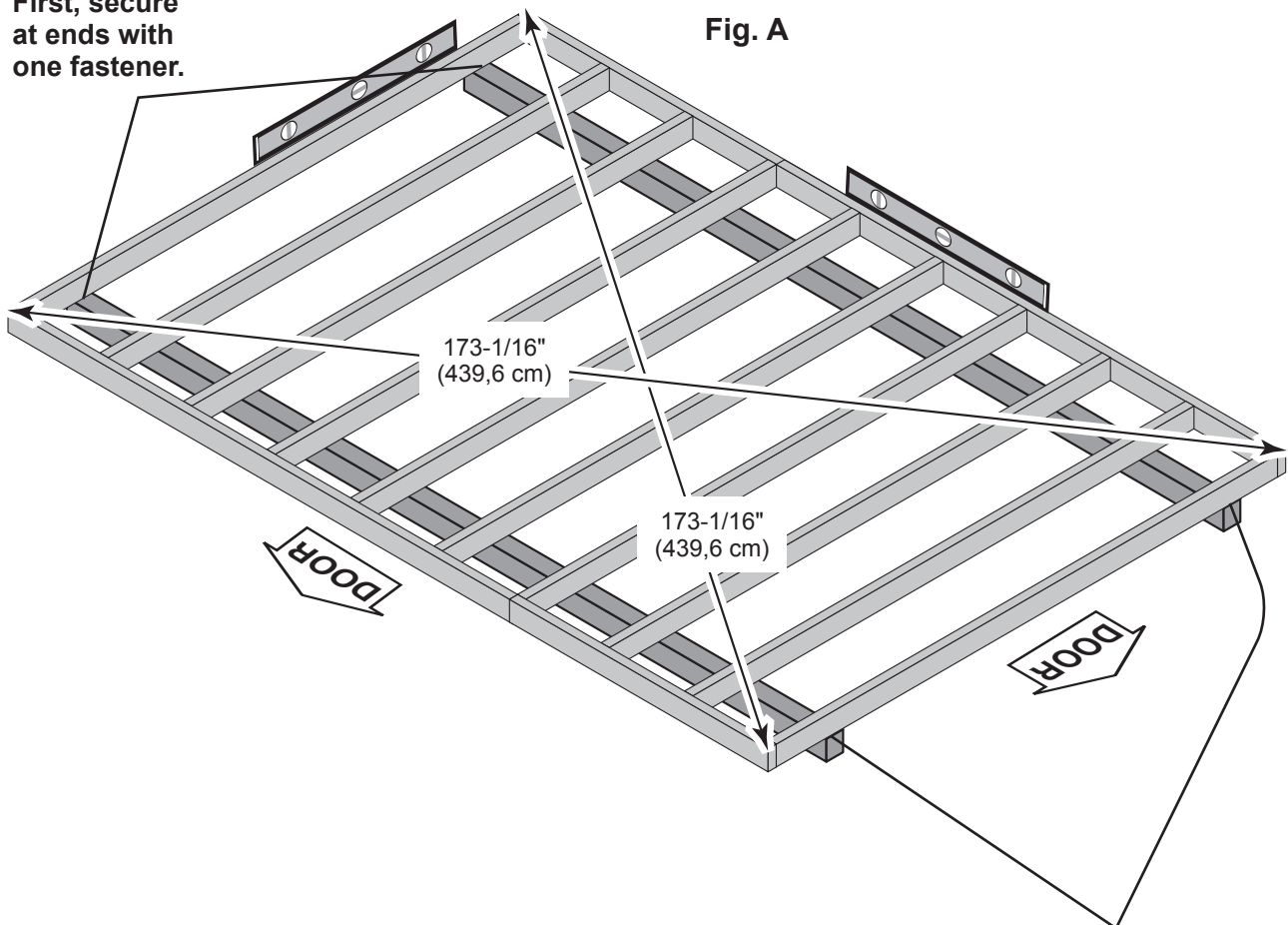

Second, secure at ends with one fastener.

IMPORTANT!

STOP!

Ensure the floor frame is level after installing floor panels.
Re-level if needed.

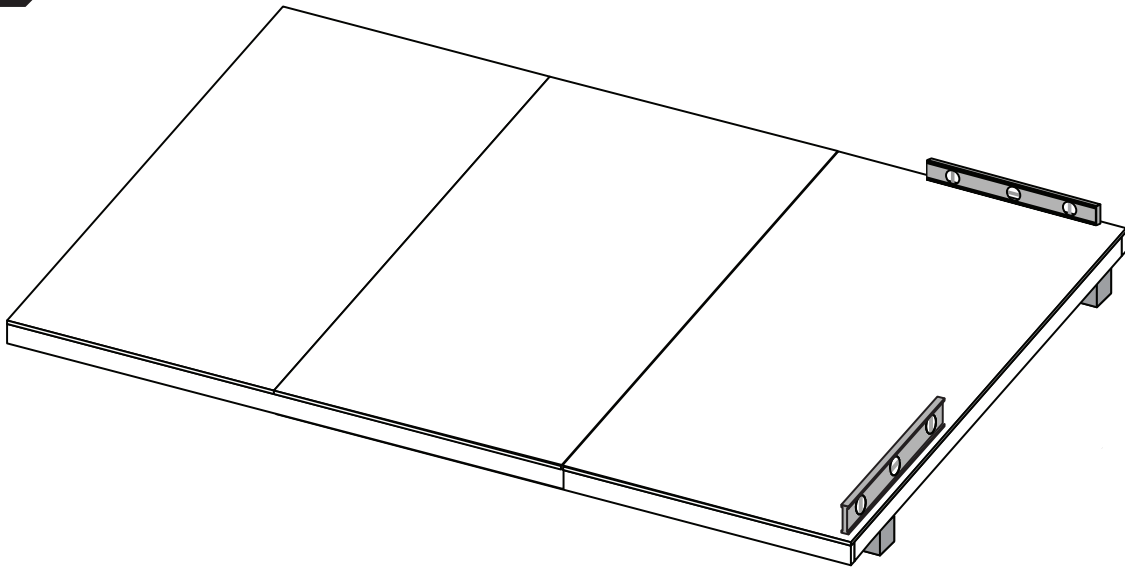

HINT:

- The floor should be used as a stable work surface for wall construction.
- Organize your assembly procedure during the build process to avoid over-handling of the walls.

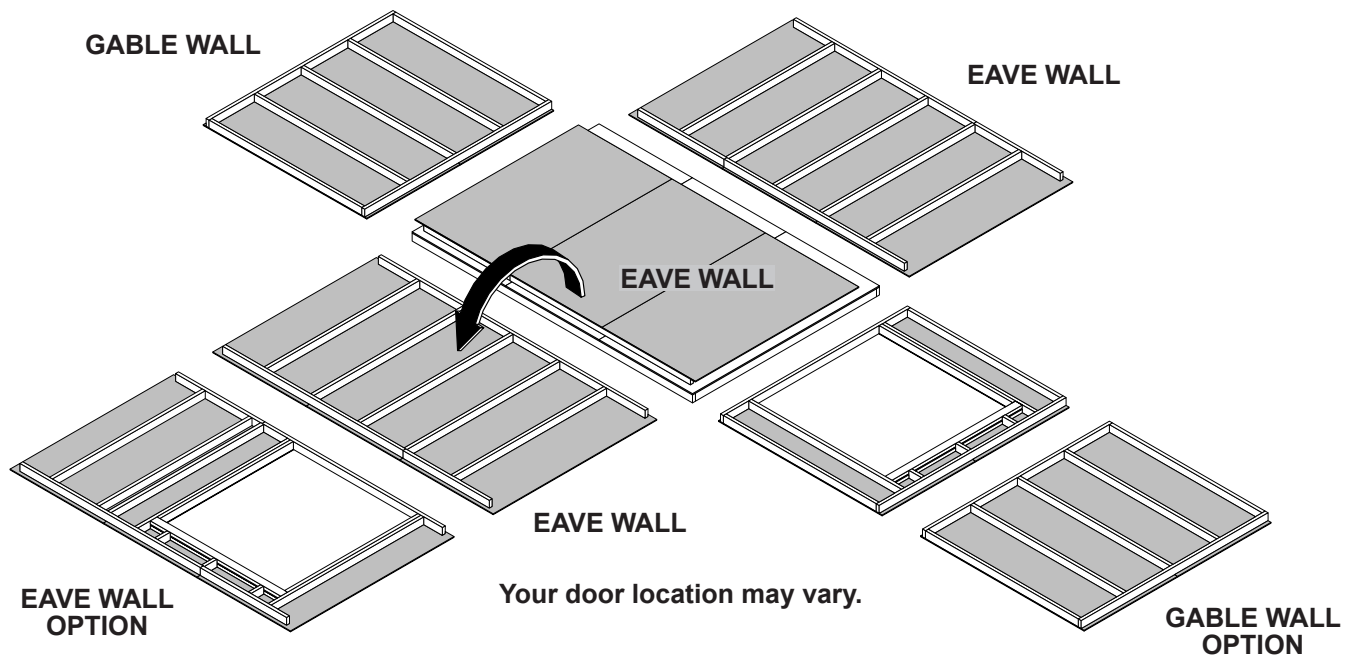

RAFTER ASSEMBLY

PARTS REQUIRED:

x2 **UY** 2 x 4 x 6-1/2" (5,1 x 10,2 x 16,5 cm)

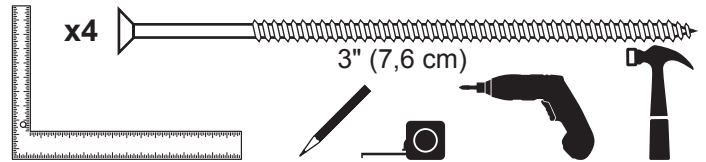

Build a rafter jig using the floor and (2) UY parts.

✓ **BEGIN**

- 1 Secure (1) **UY** flush to the floor deck with (2) 3" screws (**Fig. A**).
Measure over 96-3/4" (243,8 cm) and install a second **UY** flush to the floor deck.
Secure with (2) 3" screws.

Fig. A

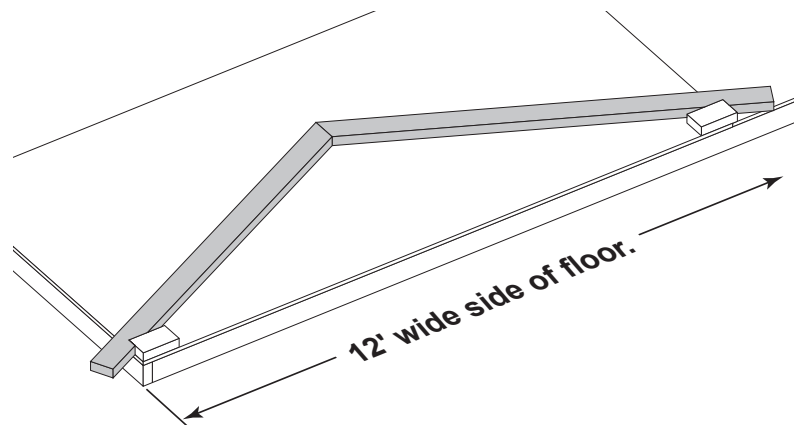
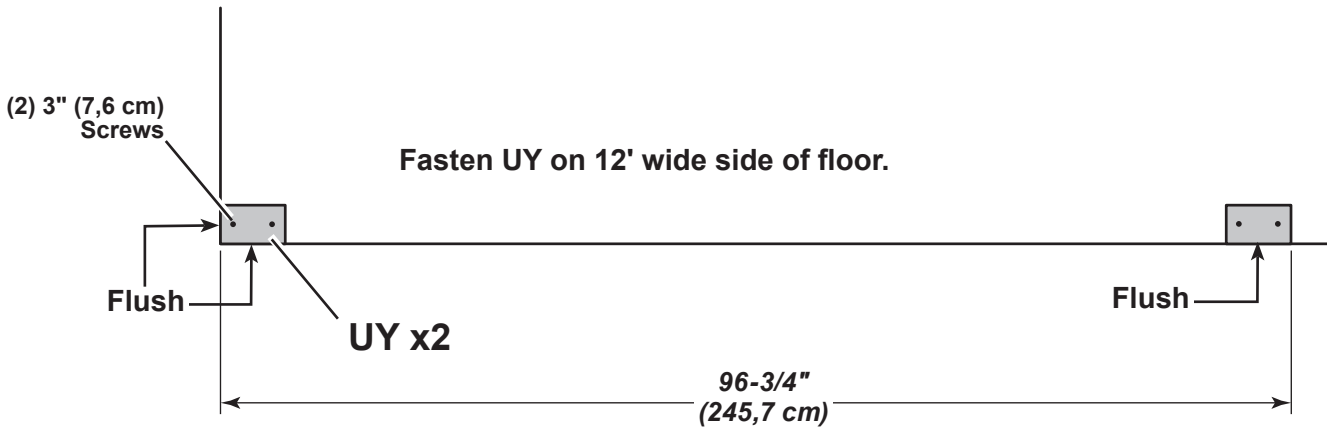

FINISH

You have finished rafter jig. Proceed to assemble your rafters.

RAFTER ASSEMBLY

PARTS REQUIRED:

x12  OSB OR WOOD GRAIN
6 x 24" (15,2 x 61 cm)

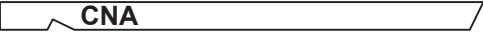
x14  CNA
2 x 4 x 61-7/8" (5,1 x 10,2 x 157,2 cm)

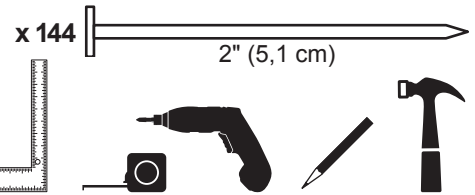

Build (2) rafter assemblies with (1) gusset (Fig. C).

✓ BEGIN

- Place (2) rafters **CNA** in the jig, as shown. Hold **CNA** firm against **UY**'s as shown (**Fig. A**). Rafters should touch at tips (**Fig. B**).
- Place gusset on **CNA**, holding a 1/4" gap from edge (**Fig. B**) and keeping rafters firm, as instructed. Secure the gusset to the rafters with (12) 2" nails in the pattern shown (**Fig. B**).

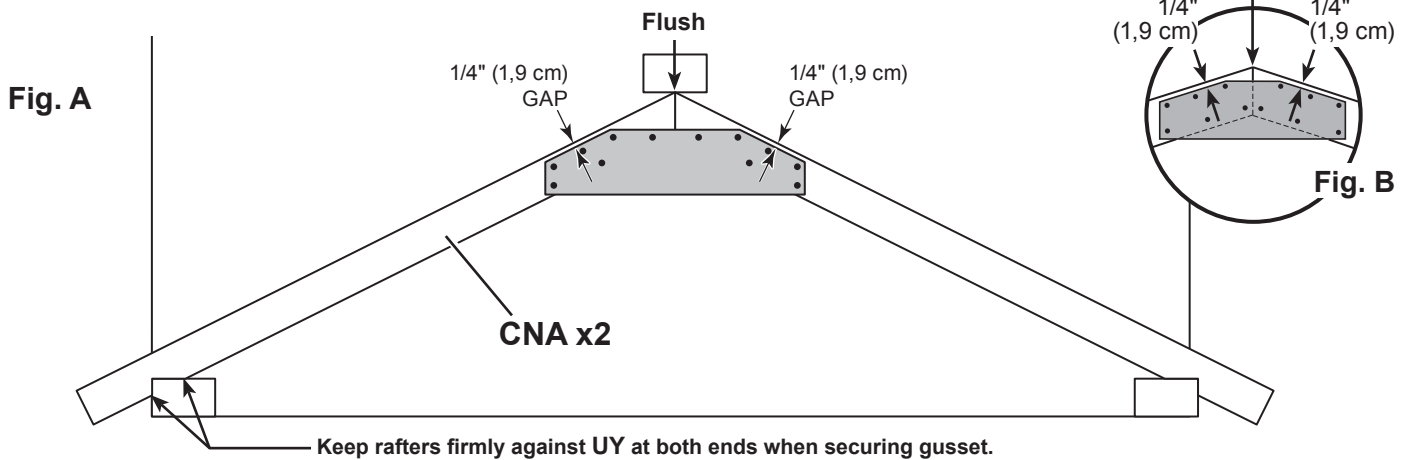

⚠ SET ASIDE THESE TWO RAFTER ASSEMBLIES.

Build (5) rafter assemblies with (2) gussets (Fig. D).

- Place two rafter-halves **CNA** in the jig, as shown (STEP - 1). Flush rafters at peak. Secure gusset to rafters with 2" nails following the pattern shown (**Fig. B**).
- Flip rafters over and fasten a second gusset with (12) 2" nails. No need to use jig for the 2nd gusset.

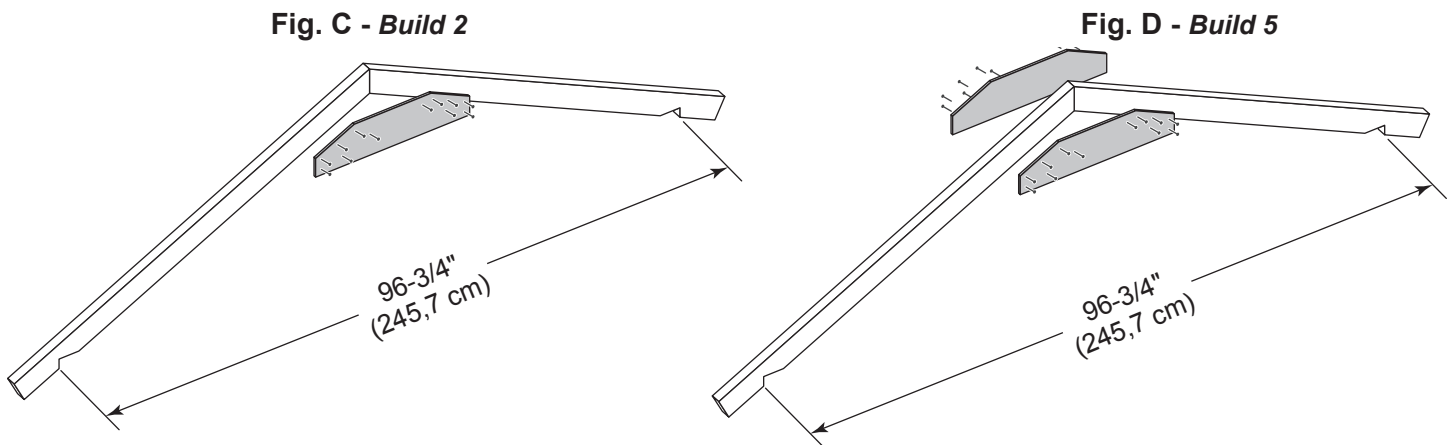

You have finished assembling your rafters.

Remove jig parts **UY** from floor.

WALL INDEX

Create your own style of shed. Choose your door location.
Use this guide to find the corresponding wall construction and installation pages.

As another option, eave walls with doors can be reversed during assembly.



IMPORTANT! Build your door header before building any walls (see page 15).

8' x 12' Door on gable wall

After assembling the walls for your 8' x 12' shed,
go to page 25 for wall installation.

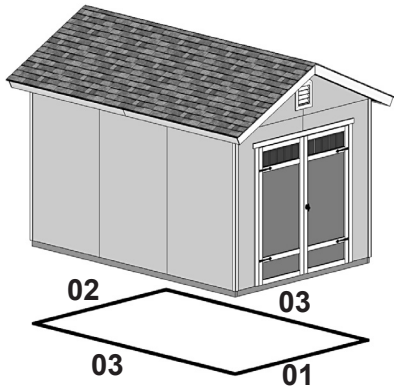

8' x 12'

Wall 01: Page 17

Wall 02: Page 19

Wall 03: Page 21 (Build 2 eave walls)

8' x 12' Door on eave wall

After assembling the walls for your 8' x 12' shed,
go to page 25 for wall installation.

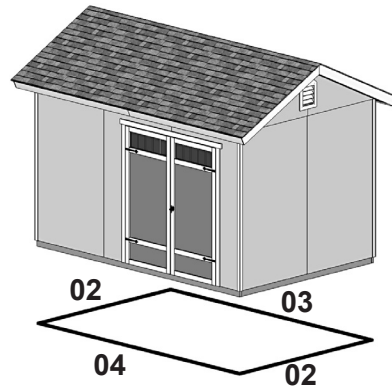

8' x 12'

Wall 02: Page 19 (Build 2 gable walls)

Wall 03: Page 21

Wall 04: Page 23

DOOR HEADER

STOP!

Assemble this door header before building any walls!

STOP!

PARTS REQUIRED:

x2 **AM**
2 x 4 x 67" (5,1 x 10,2 x 170,2 cm)

x1
7/16 x 3-1/4 x 66-3/4" (1,1 x 8,3 x 170,2 cm) **OSB**

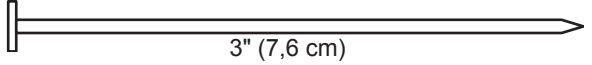
x18  3" (7,6 cm)

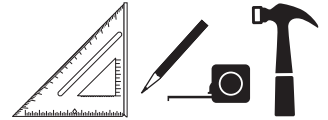

✓ BEGIN

- 1 Place (1) **AM** and **OSB** end-to-end on flat surface, flush in middle.
Center **OSB** on top of **AM**.

Fasten together with 3" nails in the pattern shown.

- 2 Flip header assembly over and nail as shown on the other side.

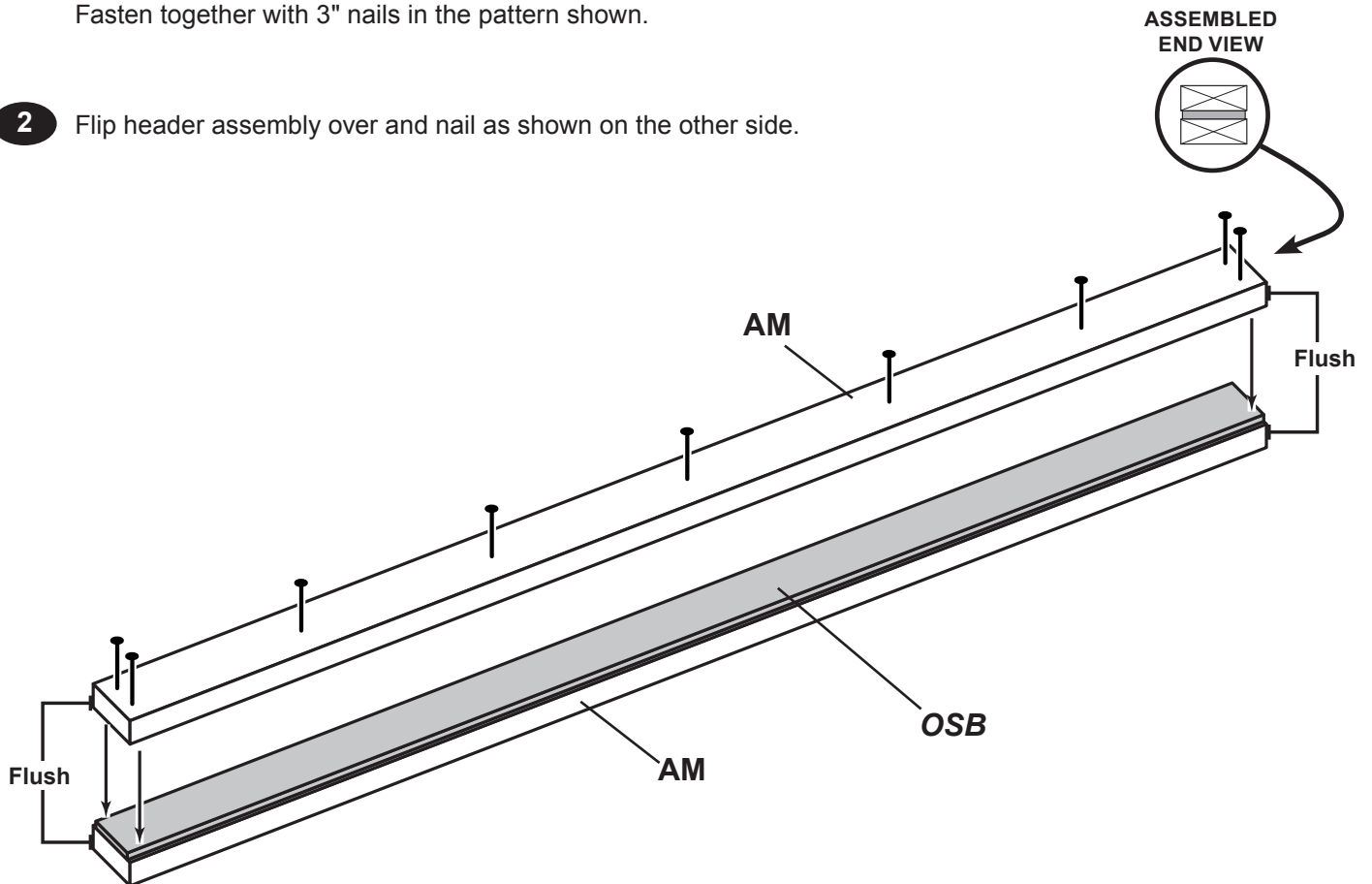

Your door header is now assembled.

WALL PANEL INSTALLATION HINTS & EXAMPLES

PARTS REQUIRED:

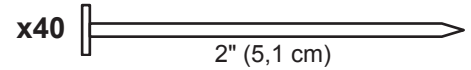
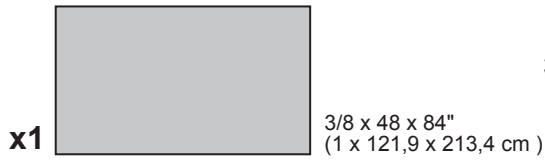

Ensure your wall is square by installing one panel and squaring frame.

Install all wall panels with the primed side facing up.

✓ **BEGIN**

- Place (1) 48" x 84" panel on the wall frame, as shown.
Locate the panel 1-1/2" above the top plate.
Use a 2x4 as a gauge block for the 1-1/2" top overhang measurement.
Use the **GAA** gauge block to mark the 3/4" side measurement on the wall stud.
Secure panel with (2) 2" nails in the corners (**Fig. A**).

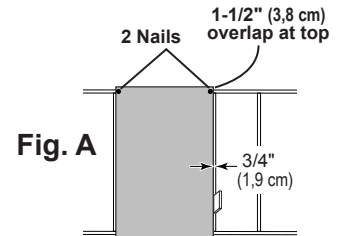

- Move to the opposite end. Using the long edge of the panel as a lever, move the panel side-to-side until you have a 3/4" measurement on the wall stud.
Secure corner with (2) 2" nails (**Fig. B**).
Secure panel with 2" nails spaced 6" apart on edges and 12" apart inside panel.

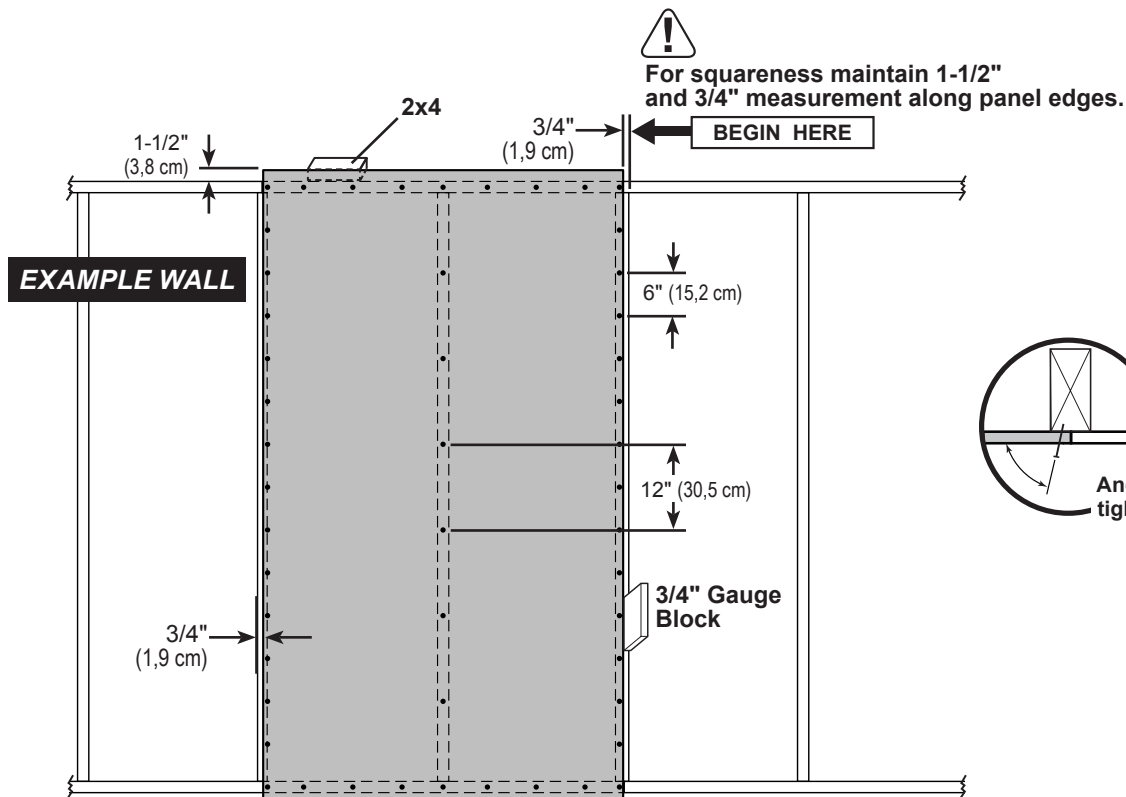
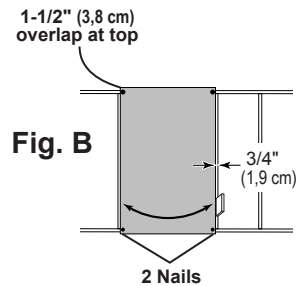

8' WALL 01

PARTS REQUIRED:

x2 **YFA**
2 x 4 x 68-1/2" (5,1 x 10,2 x 174 cm)

x4 **AI**
2 x 4 x 78-1/2" (5,1 x 10,2 x 199,4 cm)

x2 **TP**
2 x 4 x 96" (5,1 x 10,2 x 243,8 cm)

x1 **Pre Assembled Header**

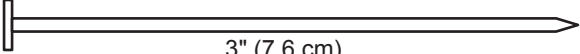
x50  3" (7,6 cm)

x6  3" (7,6 cm)

x3 **UY**
2 x 4 x 6-1/2" (5,1 x 10,2 x 16,51 cm)

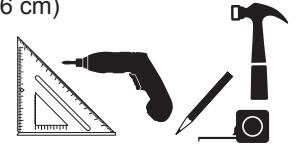

✓ BEGIN

- 1 Arrange parts on edge on floor, as shown. Measure and mark from end of boards.
Orient **Pre Assembled Header** as shown (**Fig. A**).
Secure with (2) 3" nails at each connection.



HINT:
For easier nailing
stand on frame.

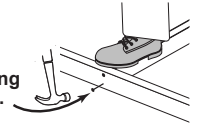

- 2 Fasten (3) middle parts **UY** to **Pre Assembled Header** with (2) 3" screws (**Fig. B**).
Secure parts **UY** to top plates with (2) 3" nails at each connection.

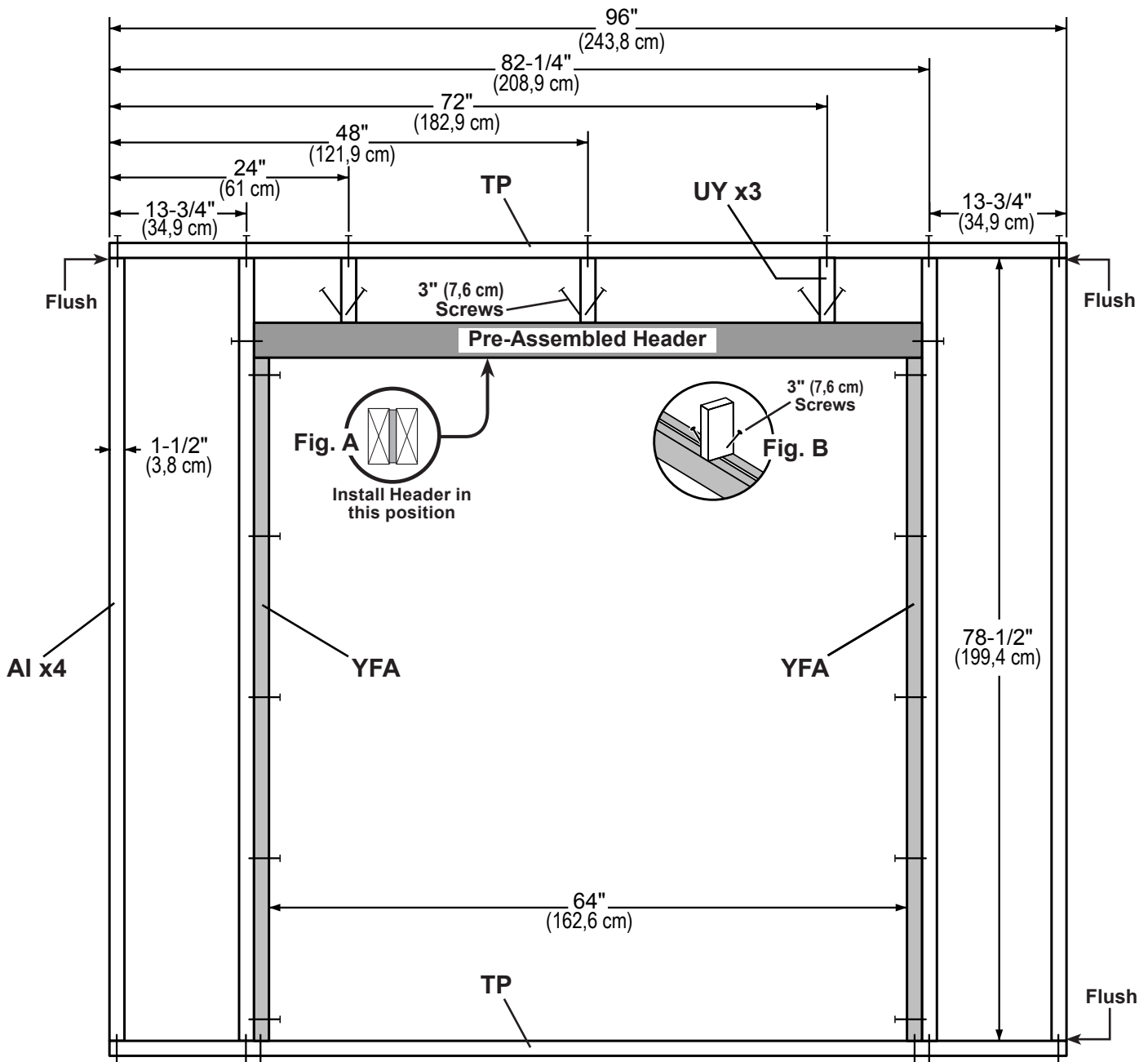

8' WALL 01

PARTS REQUIRED:



3/4" GAUGE
BLOCK



2x4
TEMP. SPACER

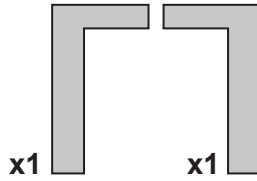

x1

x1

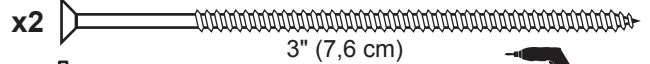

3" (7,6 cm)

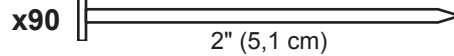

2" (5,1 cm)



Install panels with the primed side facing up.

- 3 Install the left panel 1-1/2" from the top plate. Use a 2x4 spacer for consistent measurement. Secure panel with 2" nails spaced 6" apart on edges.
- 4 Install the right panel flush to installed panel, as shown. Ensure 64" (162,8 cm) door measurement. Secure panels with 2" nails spaced 6" apart on edges.

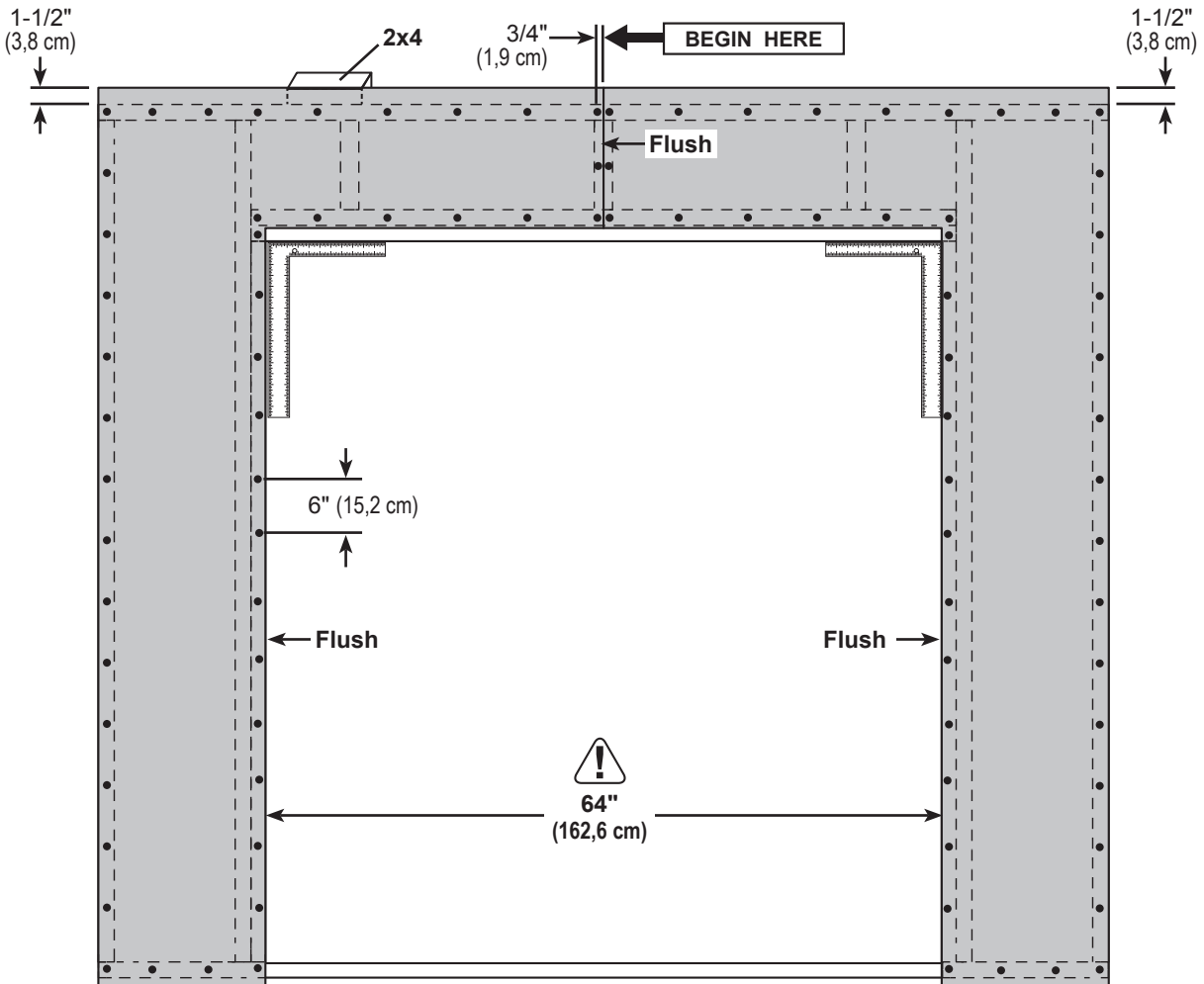

Your 8' WALL 01 is now assembled.
Carefully flip the wall over.

GABLE WALL 02

PARTS REQUIRED:

x5 **AI**
 2 x 4 x 78-1/2" (5,1 x 10,2 x 199,4 cm)

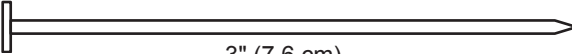
x20  3" (7,6 cm)

x2 **TP**
 2 x 4 x 96" (5,1 x 10,2 x 243,8 cm)



✓ BEGIN

- 1 Arrange parts on edge on floor. Measure and mark.
 Secure with (2) 3" nails at each mark.

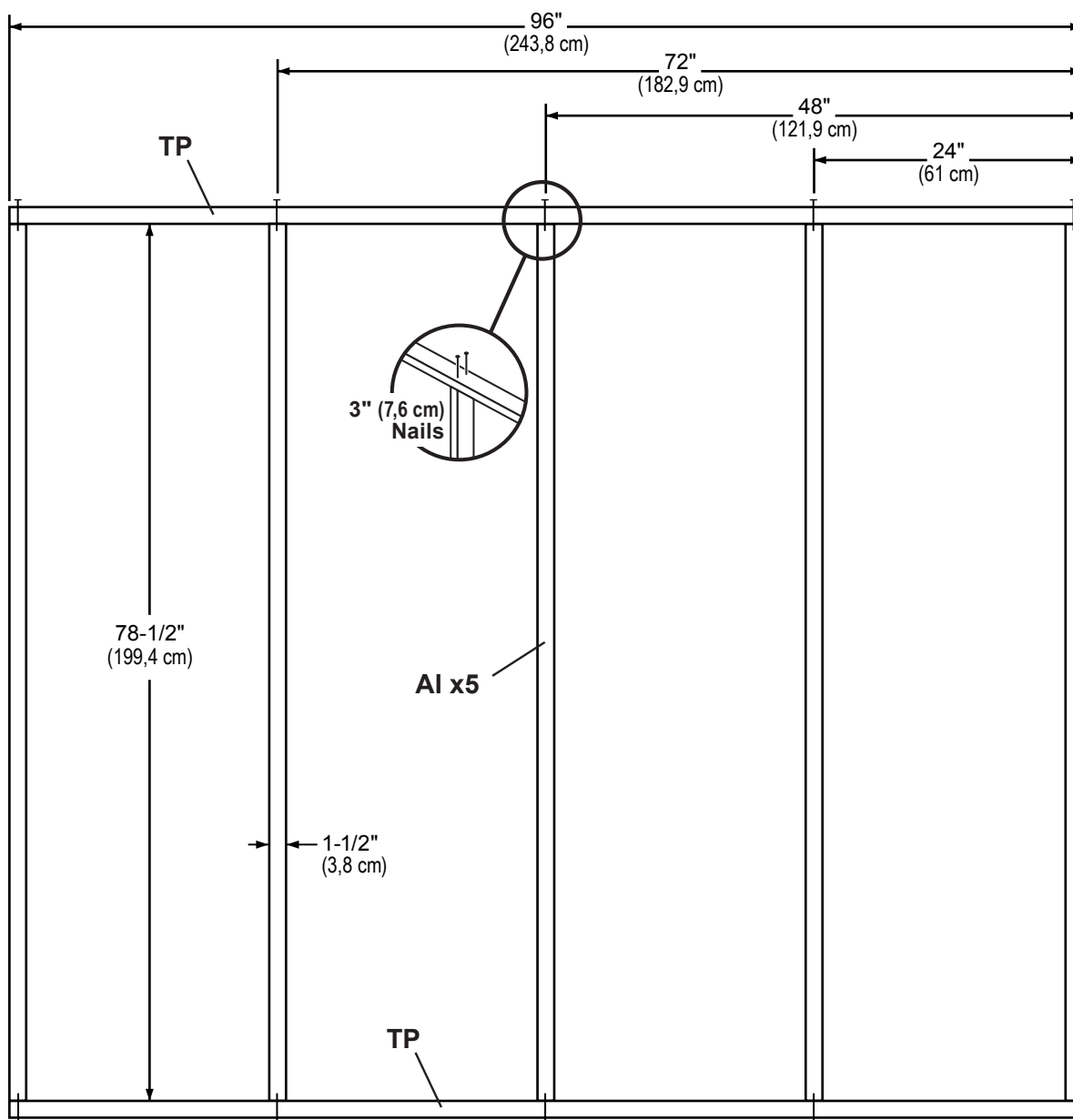

8' WALL 02

PARTS REQUIRED:

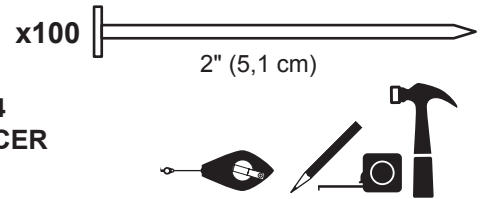

Install all panels with the primed side facing up.

2

Install (1) **48 x 84"** panel on wall frame 1-1/2" from the top plate. Use a 2x4 spacer for consistent measurement. Use the gauge block to mark the 3/4" measurement on the wall stud.

Secure the panel with 2" nails spaced 6" apart on edges and 12" apart inside panel.

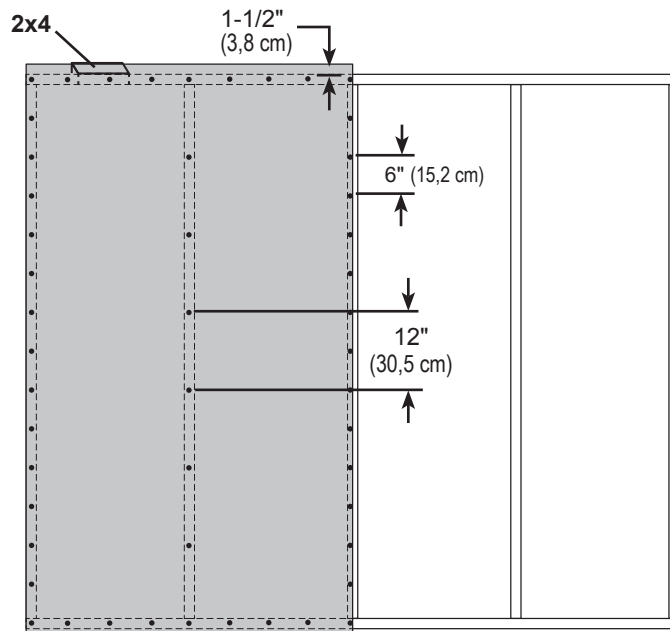

3

Install next **48" x 84"** panel flush to installed panel. Locate panel 1-1/2" from the top plate. Use a 2x4 spacer for consistent measurement.

Secure with 2" nails spaced 6" apart on edges and 12" apart inside panel.

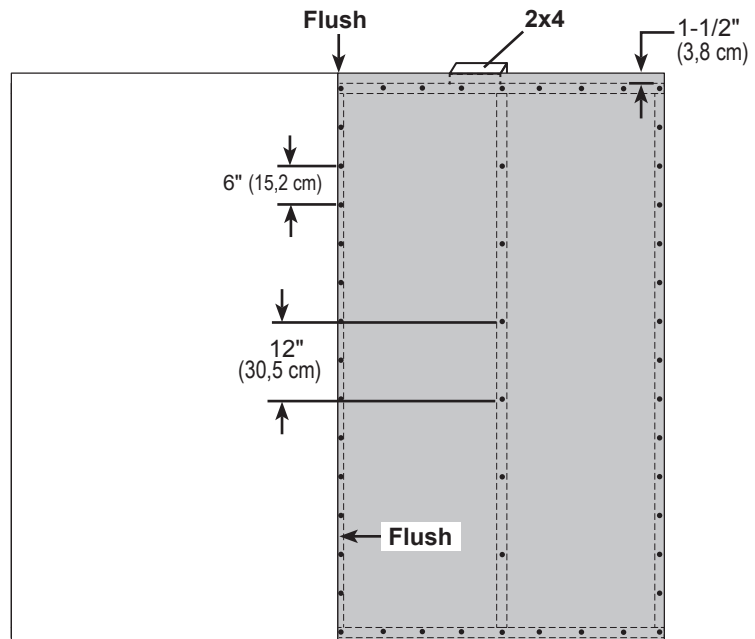

Your 8' WALL 02 is now assembled.

Carefully flip the gable wall over.

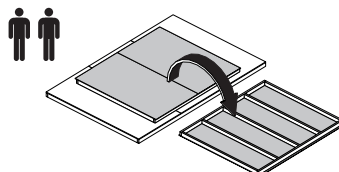

12' WALL 03

PARTS REQUIRED:

x2 **HVC** 2 x 4 x 44-3/8" (5,1 x 10,2 x 112,7 cm)

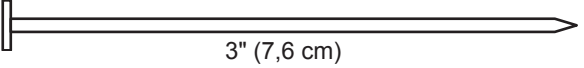
x24  3" (7,6 cm)

x5 **AI** 2 x 4 x 78-1/2" (5,1 x 10,2 x 199,4 cm)

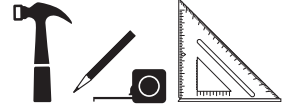

x2 **TJ** 2 x 4 x 92-5/8" (5,1 x 10,2 x 235,3 cm)

✓ BEGIN

1 Arrange parts on edge on floor. Measure and mark.

Secure with (2) 3" nails at each mark and (4) 3" nails at seams.



HINT:
For easier nailing
stand on frame.

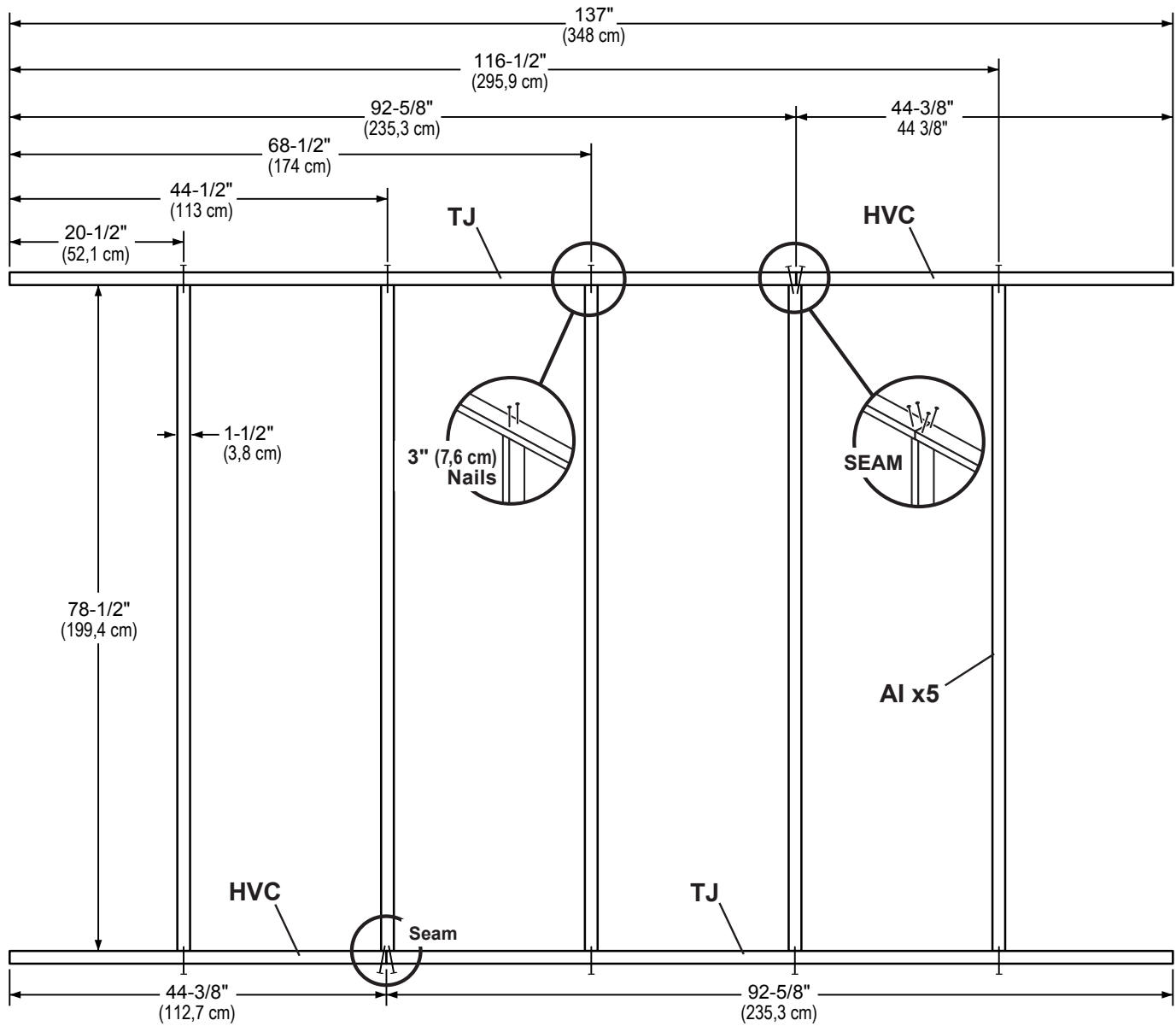
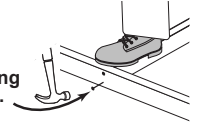

12' WALL 03

PARTS REQUIRED:

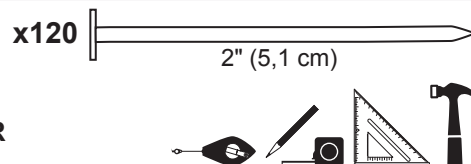
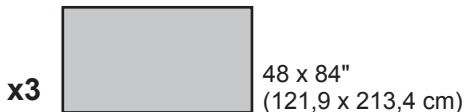

Install all panels with the primed side facing up.

2

Install (1) **48 x 84"** panel on wall frame 1-1/2" from the top plate. Use a 2x4 spacer for consistent measurement. Use the gauge block to mark the 3/4" measurement on the wall stud.

Secure the panel with 2" nails spaced 6" apart on edges and 12" apart inside panel.

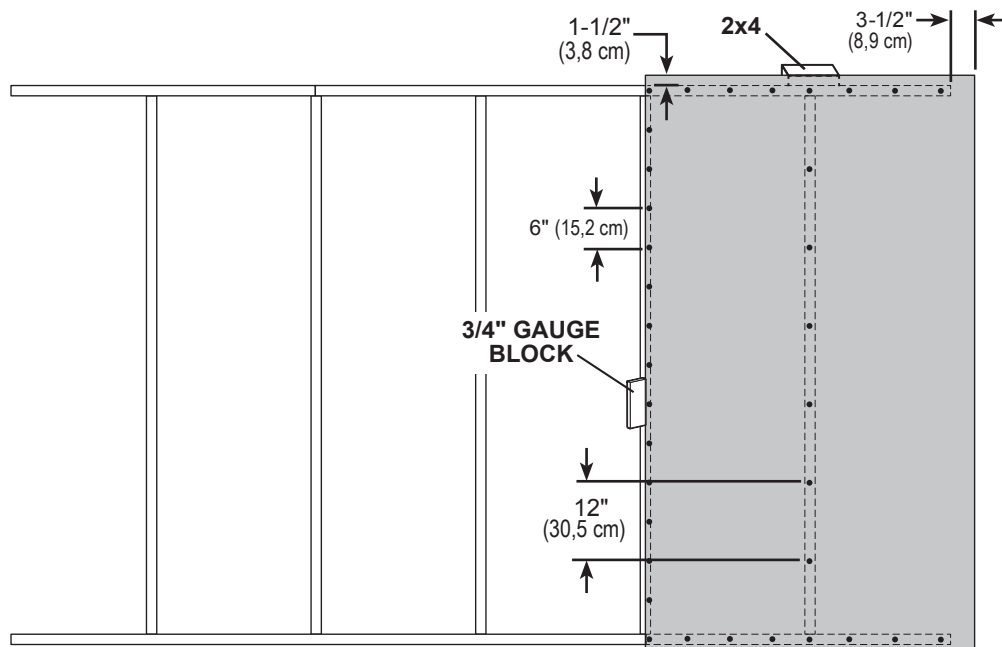

3

Install (2) **48" x 84"** panels flush to installed panels. Locate panels 1-1/2" from the top plate. Use a 2x4 spacer for consistent measurement.

Secure with 2" nails spaced 6" apart on edges and 12" apart inside panel.

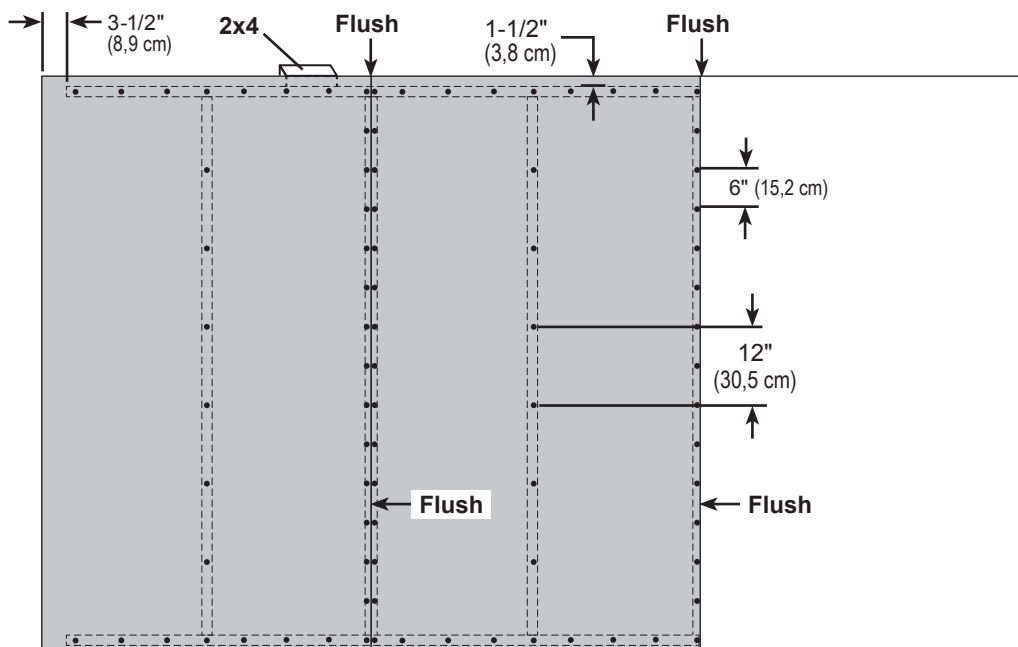

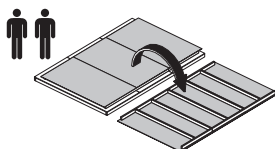

Your 12' WALL 03 is now assembled.

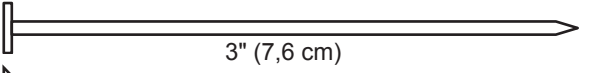
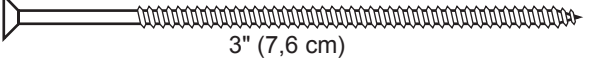

Carefully flip the eave wall over.

12' WALL 04

PARTS REQUIRED:	x3	UY	x58	
		2 x 4 x 6-1/2" (5,1 x 10,2 x 16,5 cm)		3" (7,6 cm)
x2	HVC	2 x 4 x 44-3/8" (5,1 x 10,2 x 112,7 cm)	x6	
				3" (7,6 cm)
x5	AI	2 x 4 x 78-1/2" (5,1 x 10,2 x 199,4 cm)		
x2	TJ	2 x 4 x 92-5/8" (5,1 x 10,2 x 235,3 cm)		
x1	Pre Assembled Header		x2	YFA
				2 x 4 x 68-1/2" (5,1 x 10,2 x 174 cm)

BEGIN

- 1 Arrange parts on edge on floor as shown. Measure and mark from end of boards. Orient **Pre Assembled Header** on flat side (**Fig. A**). Secure with (2) 3" nails at each connection and (4) 3" nails at seams.
- 2 Fasten (3) middle parts **UY** to **Pre Assembled Header** with (2) 3" screws (**Fig. B**). Secure parts **UY** to top plates with (2) 3" nails at each connection and (4) 3" nails at seam.

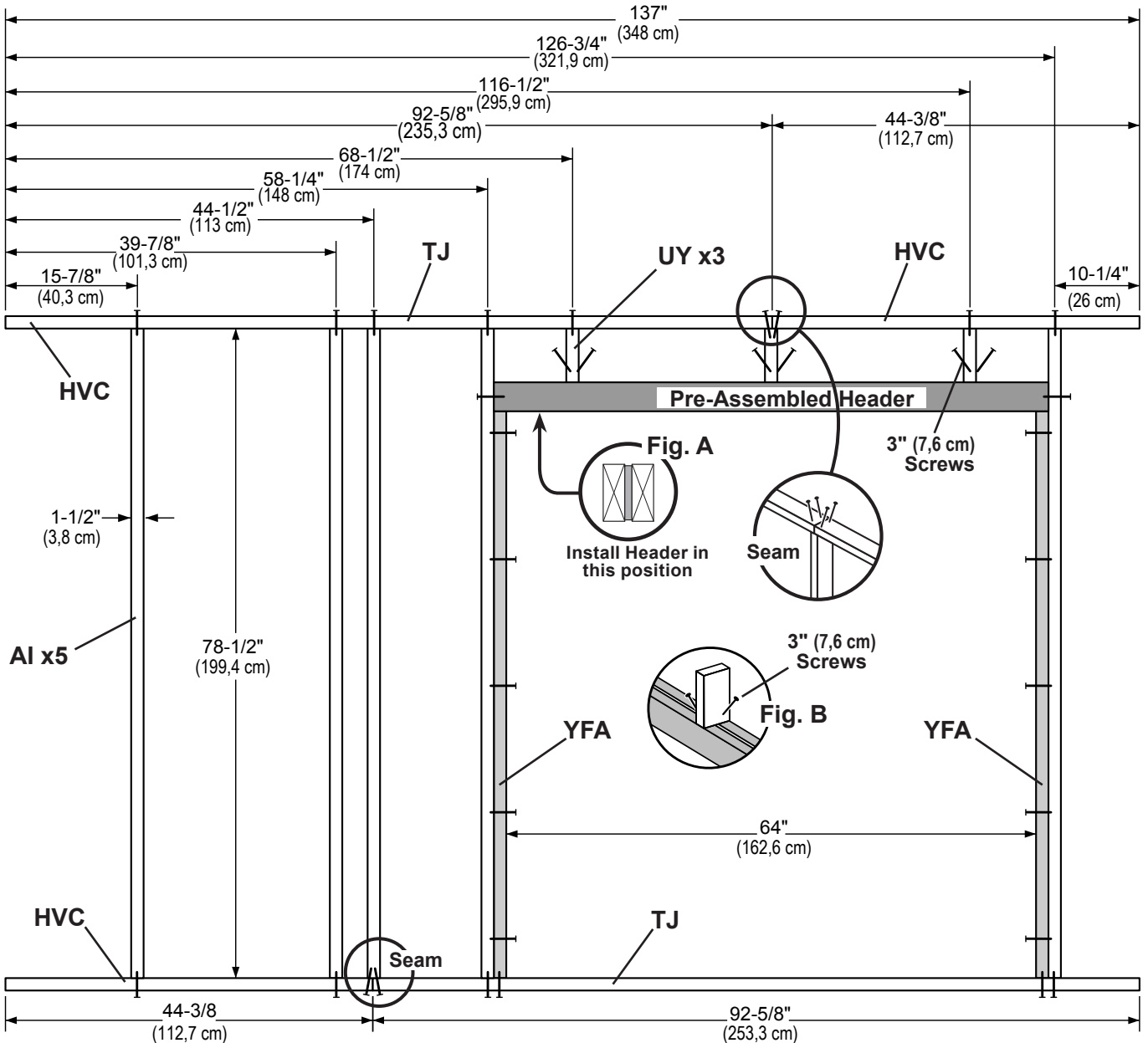

12' WALL 04

PARTS REQUIRED:

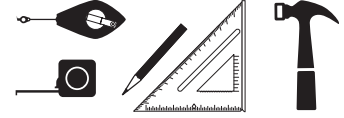
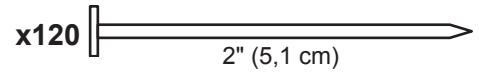
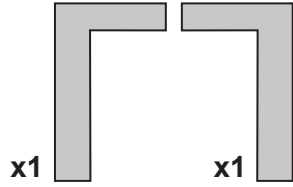
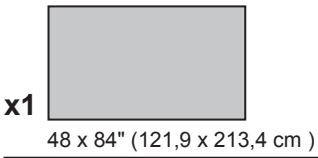

3

Install the left panel 1-1/2" from the top plate. Use a 2x4 spacer for consistent measurement.

Secure panel with 2" nails spaced 6" apart on edges.

4

Install the right panel flush to installed panel, as shown. Ensure 64" (162,8 cm) door measurement.

Secure panel with 2" nails spaced 6" apart on edges.

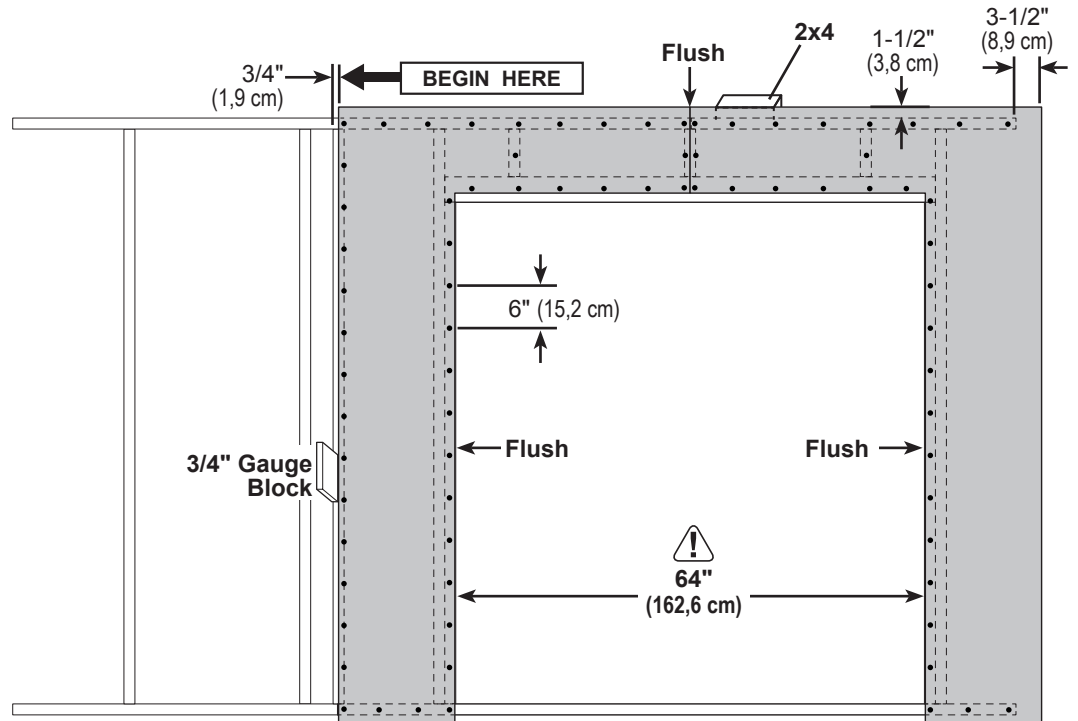

5

Install 48" x 84" panel flush to installed panel and 1-1/2" from the top plate.

Secure panels with 2" nails spaced 6" apart on edges.

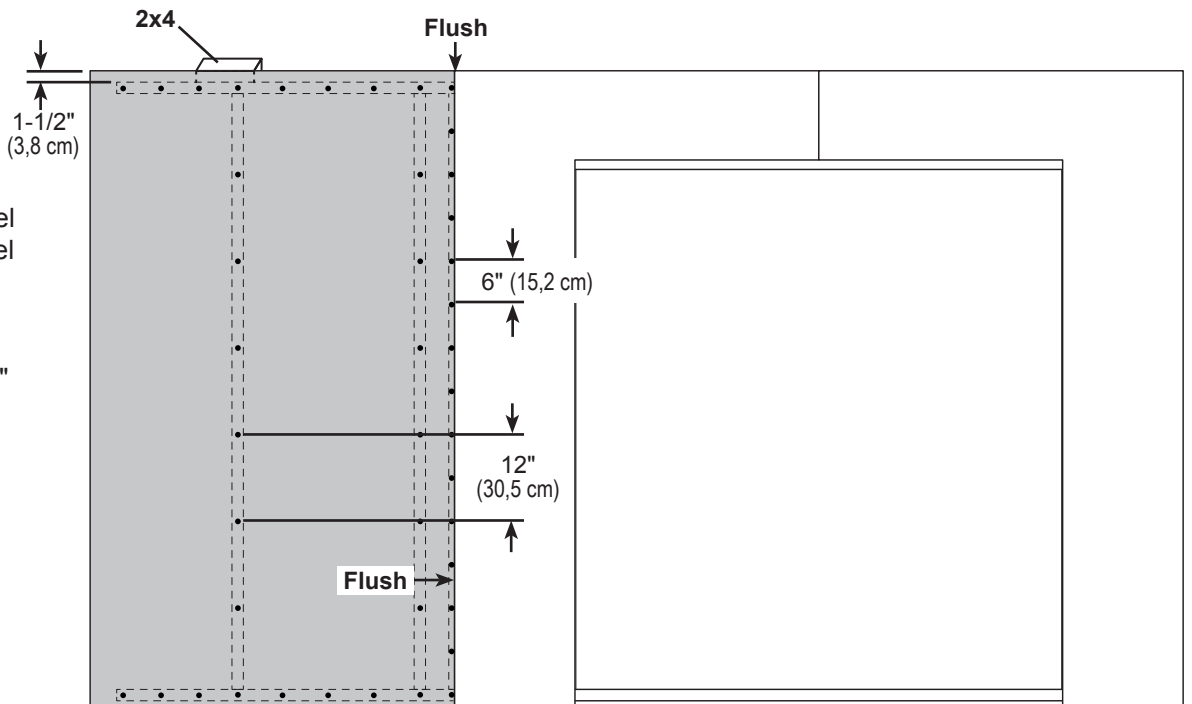

Your 12' WALL 04 is now assembled. Carefully flip the wall over.

STANDING YOUR WALLS

The following steps show how to stand and secure your walls.
These instructions are by default with the door on the 8' gable wall.

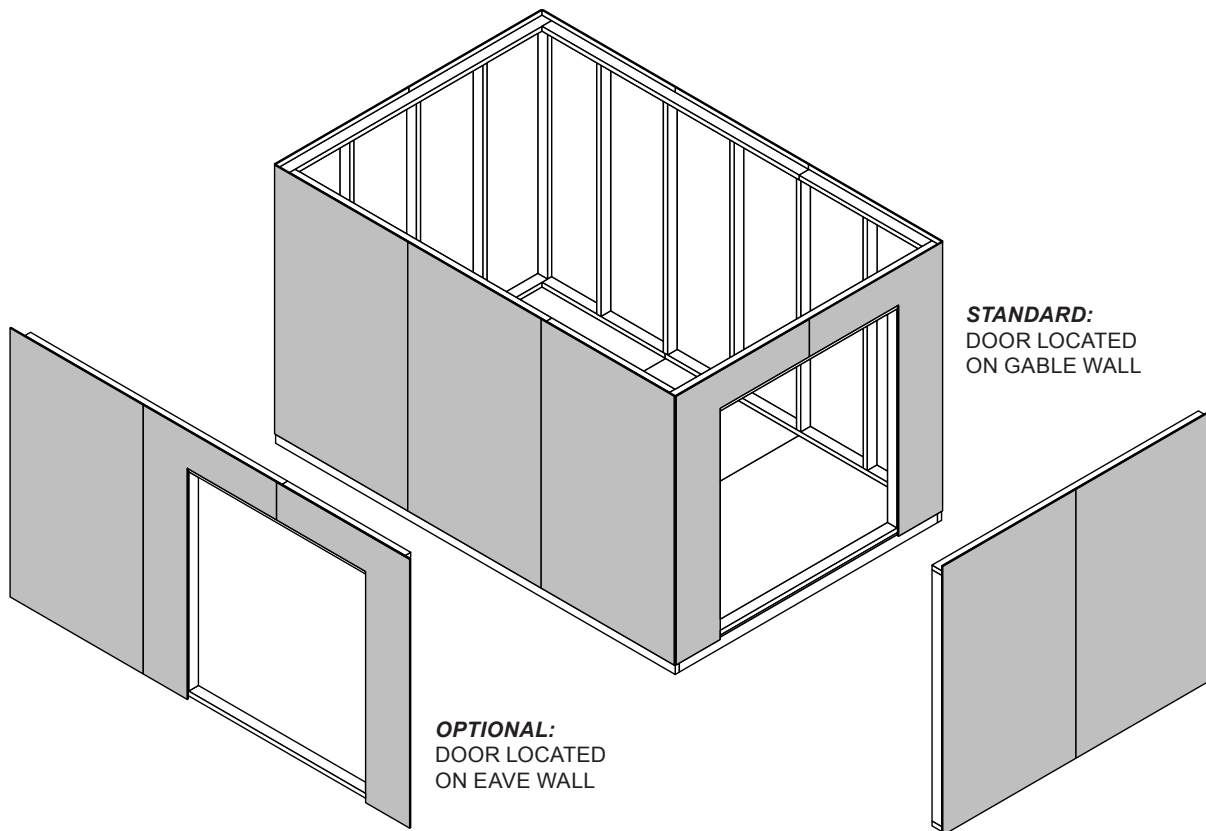

8' WALL 01 INSTALLATION

PARTS REQUIRED:

x1 **OO**
69" (175,3 cm) Door Stiffener



x8 3" (7,6 cm)
 x2 3" (7,6 cm)
 x18 2" (5,1 cm)

✓ BEGIN

- Center 8' wall on the 96" (243,8 cm) floor dimension.
1-1/2" (3,8 cm) overlap is to the top.

Use **OO** as a temporary brace.
Secure with (2) 3" screws.

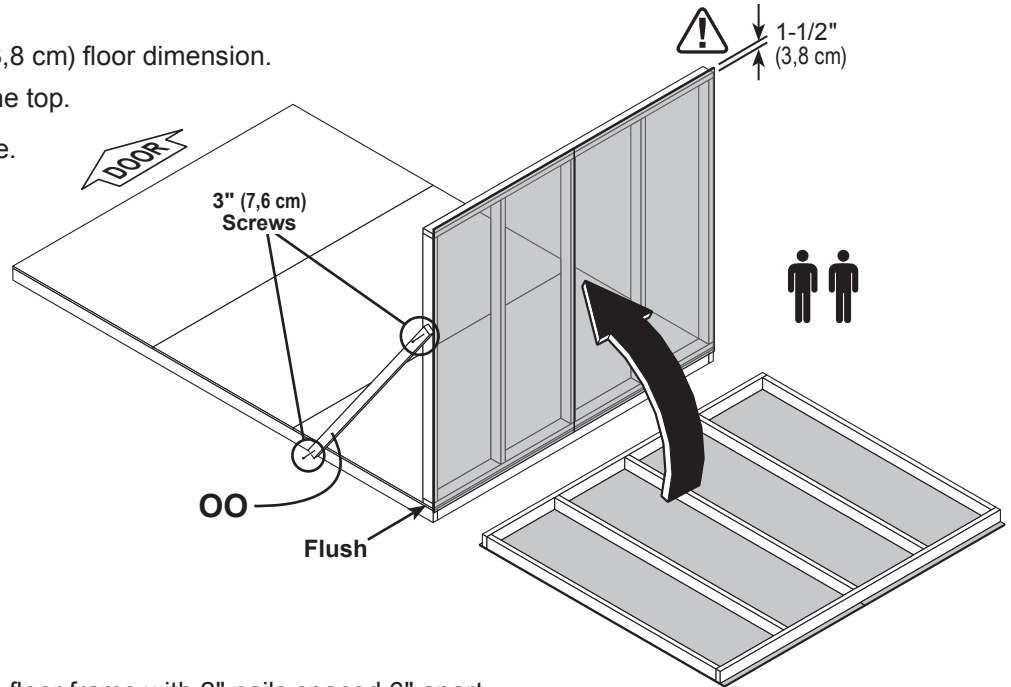

- Secure lower edge of panel to floor frame with 2" nails spaced 6" apart.
Angle nails into floor frame (**Fig. A**).

Secure wall bottom plates to floor with 3" nails (**Fig. A**).

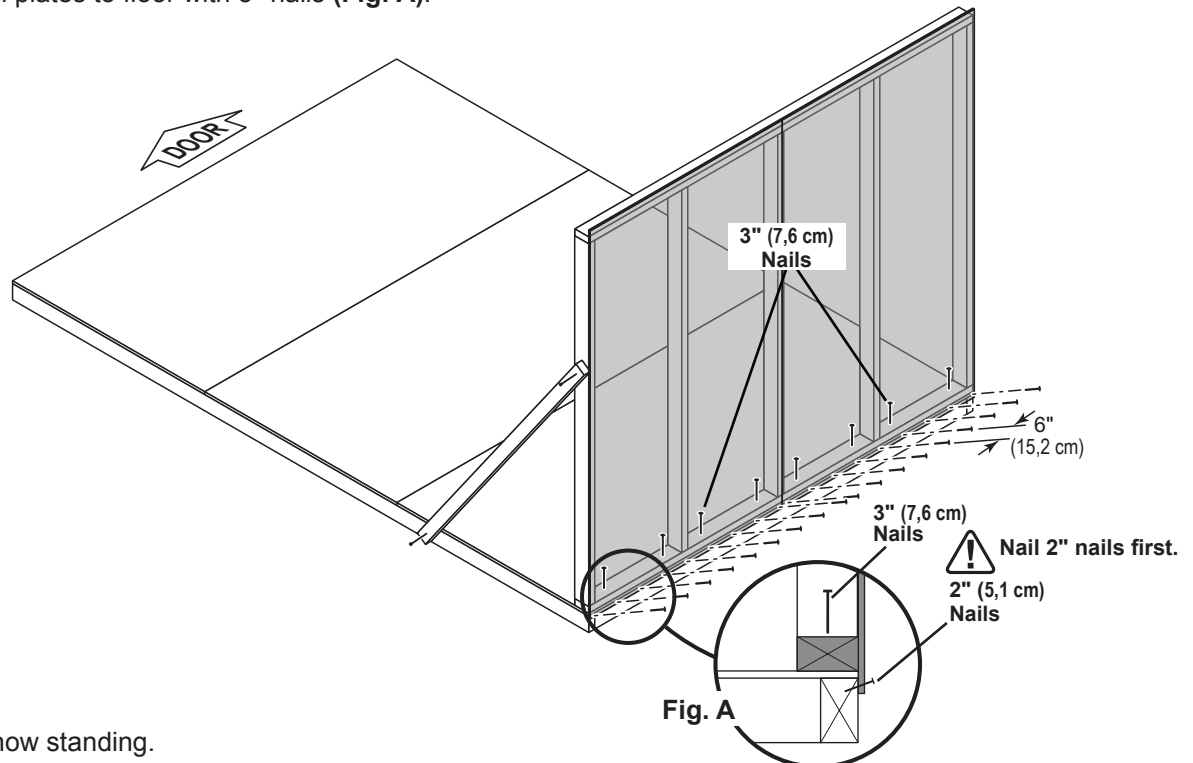

Your 8' wall 01 is now standing.

12' WALL 03 or 04 INSTALLATION

PARTS REQUIRED

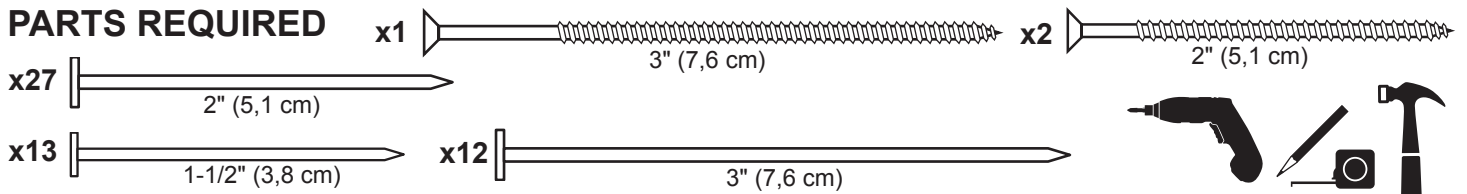

✓ BEGIN

- Place 12' wall centered on floor.
1-1/2" (3,8 cm) overlap is to the top.

Secure wall with (1) 2" screw into 10' wall bottom plate (**Fig. A**) and top plate (**Fig. B**).

Secure wall to bottom plate first.
ENSURE PANEL CORNERS ARE FLUSH.

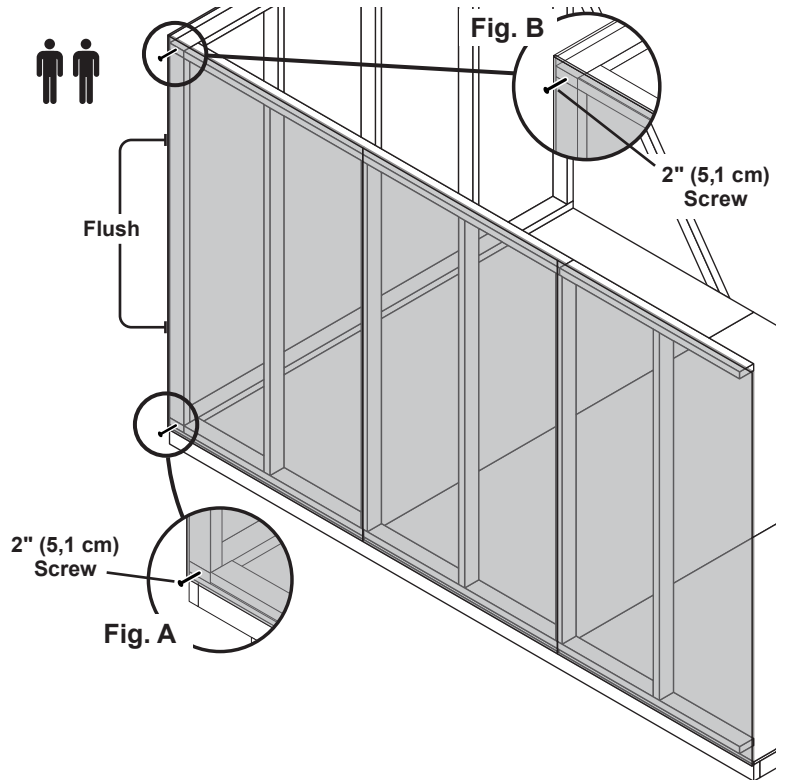
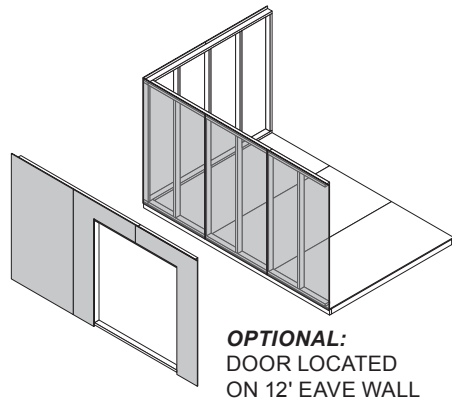

- Nail lower edge of panels to floor with 2" nails spaced 6" apart.
Angle nails into floor frame (**Fig. C**).

Nail panel to 8' wall stud with 1-1/2" nails spaced 6" apart.

- Secure wall top plate with (1) 3" screw angled at the corner at an angle as shown (**Fig. D**).

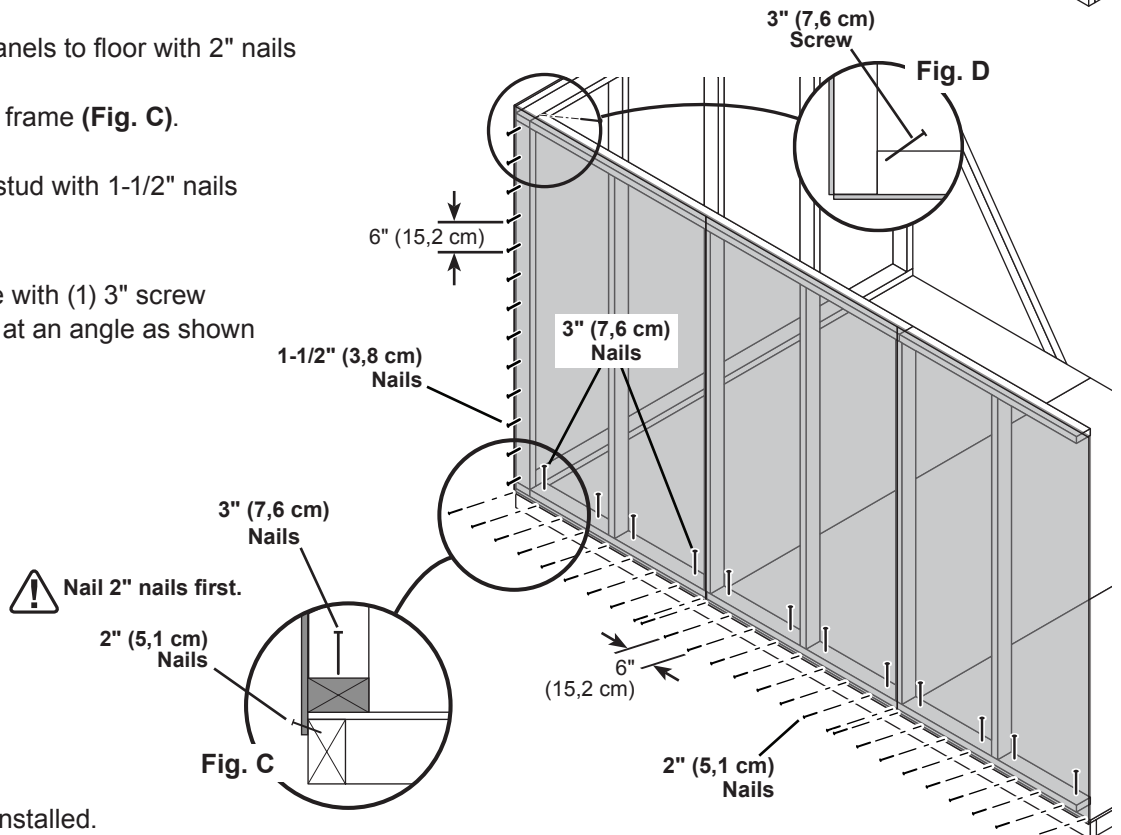

Your 12' wall is now installed.

12' WALL 03 INSTALLATION (2nd 12' wall)

PARTS REQUIRED:

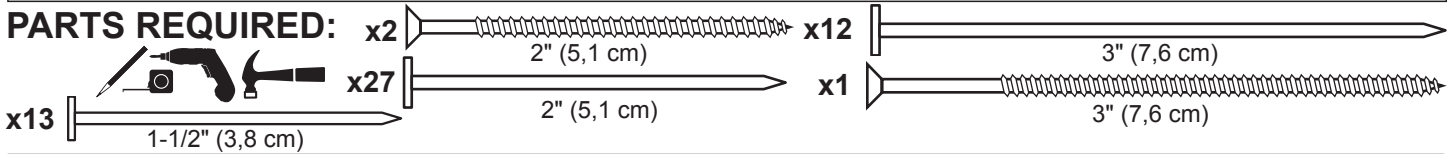

✓ BEGIN

- 1** Remove temporary brace **OO** from installed 8' wall.
 Place 12' wall centered on floor.
 1-1/2" (3,8 cm) overlap is to the top.

- 2** Secure wall with (1) 2" screw through gable wall panel into 8' wall bottom and top plates (**Fig. B, Fig. A**).
Secure wall to bottom plate first.

⚠ ENSURE PANEL CORNERS ARE FLUSH.

- 3** Nail lower edge of wall panels to floor frame with 2" nails spaced 6" apart.
 Angle nails into floor frame (**Fig. C**).

Secure wall bottom plates to floor with 3" nails (**Fig. C**).

- 4** Nail 12' wall panel to 8' wall stud with 1-1/2" nails spaced 6" apart.

- 5** Secure gable wall top plate with (1) 3" screw at the corner at an angle as shown (**Fig. D**).

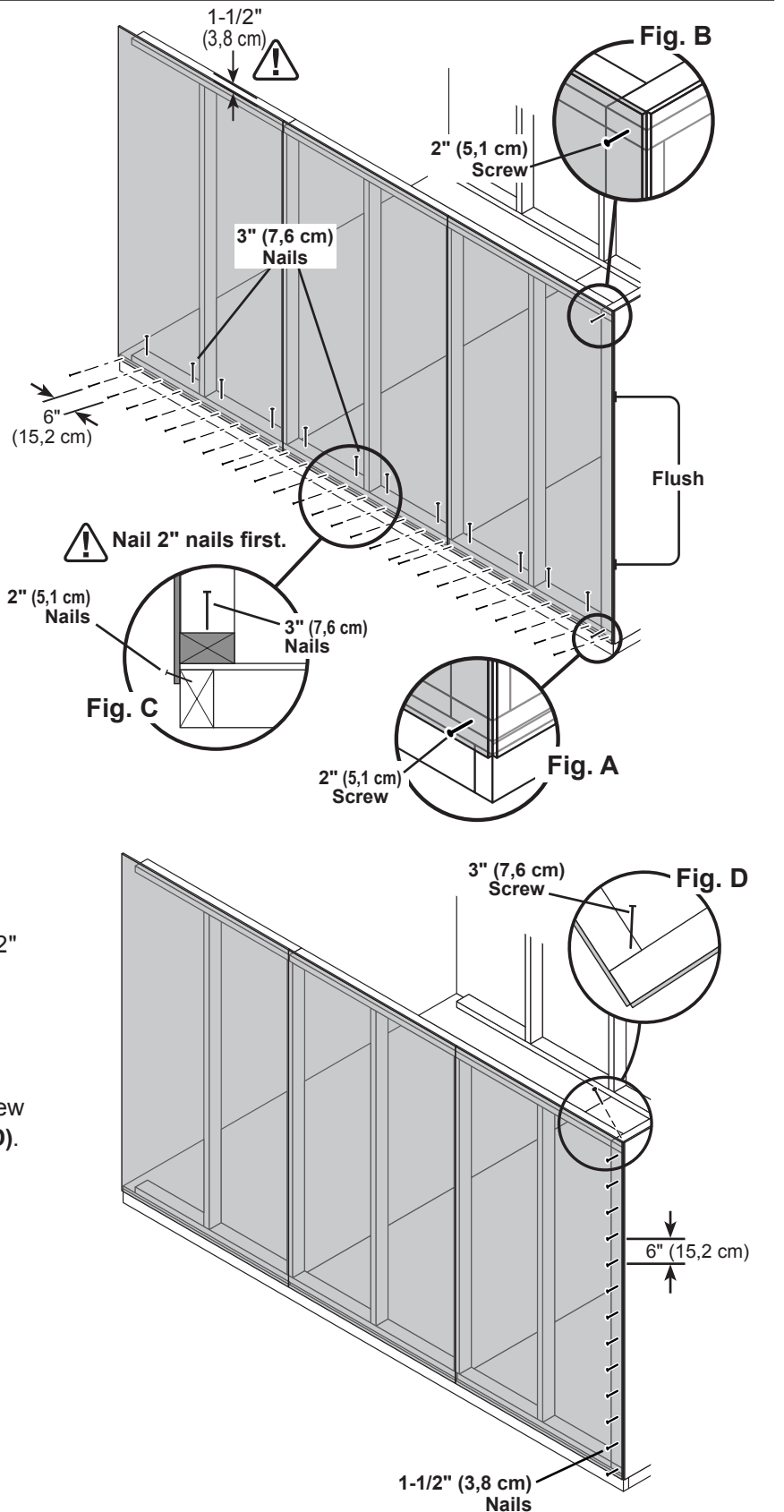

Your 2nd 12' wall is now installed.

8' GABLE WALL 01 INSTALLATION

PARTS REQUIRED:

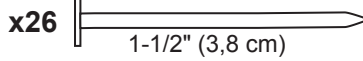
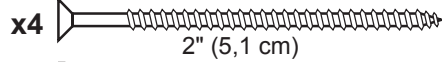
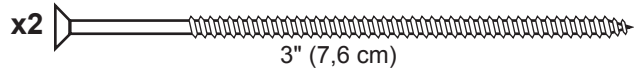
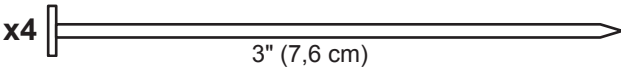
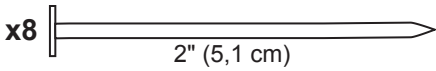

✓ BEGIN

1 Place 8' gable wall on floor, centered between installed walls. 

Secure wall with (1) 2" screw through the eave wall panel into 8' wall bottom plate (**Fig. A**) and top plate (**Fig. B**).

Secure wall to bottom plate first.

⚠ ENSURE PANEL CORNERS ARE FLUSH.

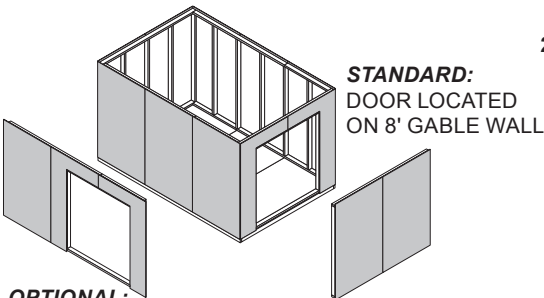

OPTIONAL:
DOOR LOCATED
ON 12' EAVE WALL

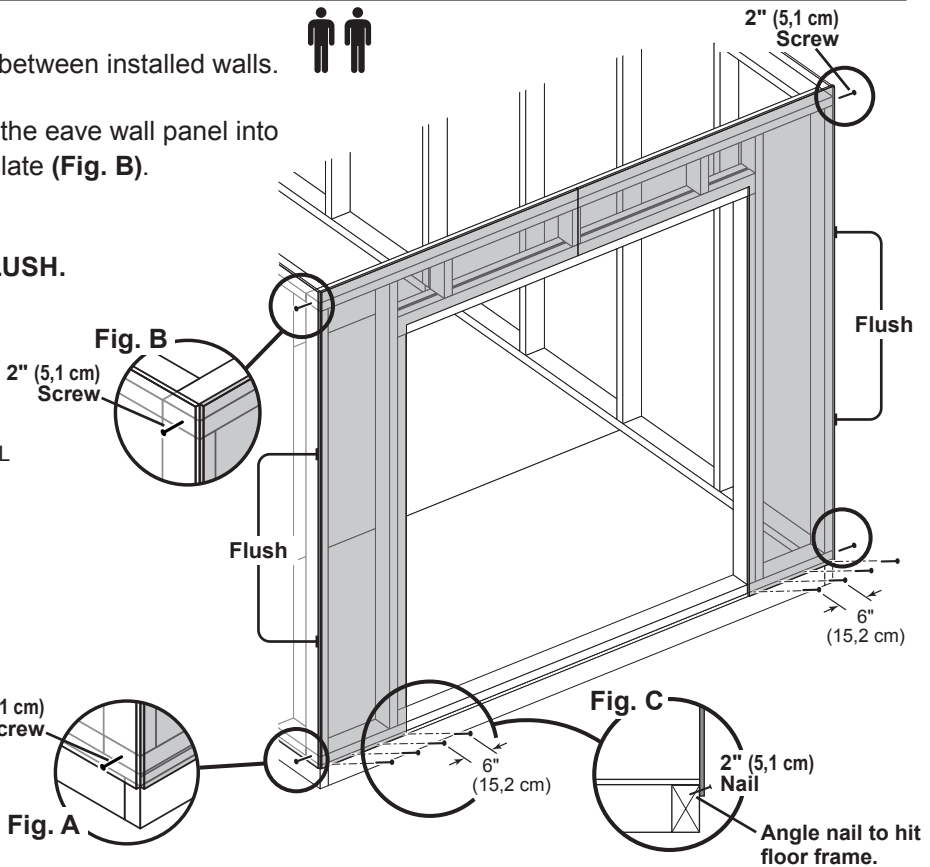

2 Nail lower edge of panels to floor with 2" nails spaced 6" apart. Angle nails into floor frame (**Fig. C**).

3 Secure 12' wall panel to 8' wall stud with 1-1/2" nails spaced 6" apart.

Secure wall bottom plates to floor with 3" nails.

4 Secure wall top plates with (1) 3" screw at both corners, angled as shown (**Fig. D**).

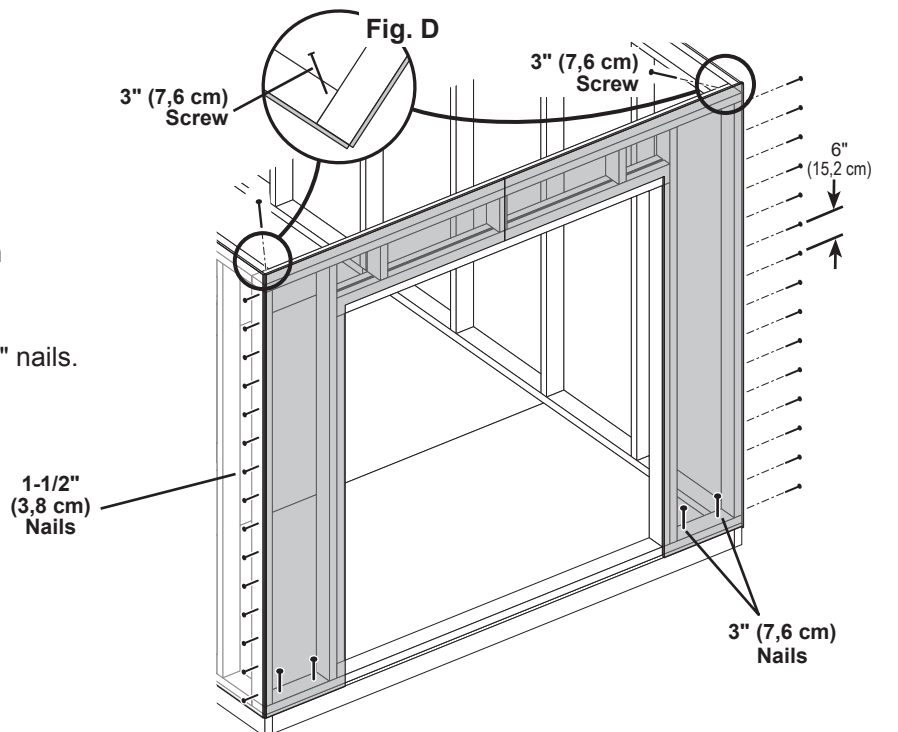

FINISH

Your walls are now installed.

WALL DOUBLERS

PARTS REQUIRED:

x2 **SP**
2 x 4 x 48" (5,1 x 10,2 x 121,9 cm)

x2 **SZ**
2 x 4 x 89" (5,1 x 10,2 x 226,1 cm)

x2 **TP**
2 x 4 x 96" (5,1 x 10,2 x 243,8 cm)

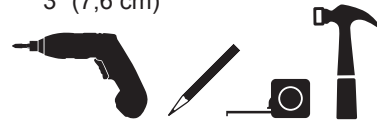
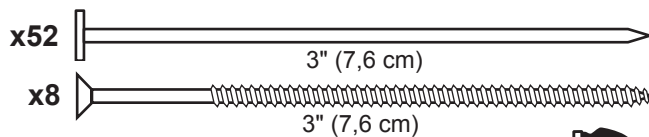

✓ BEGIN

- 1 Orient parts on top of wall frames. Measure and mark from end of boards. Secure from top with (2) 3" nails spaced every 24" (Fig. A).
- 2 Secure from bottom with (2) 3" screws at each corner (Fig. B).

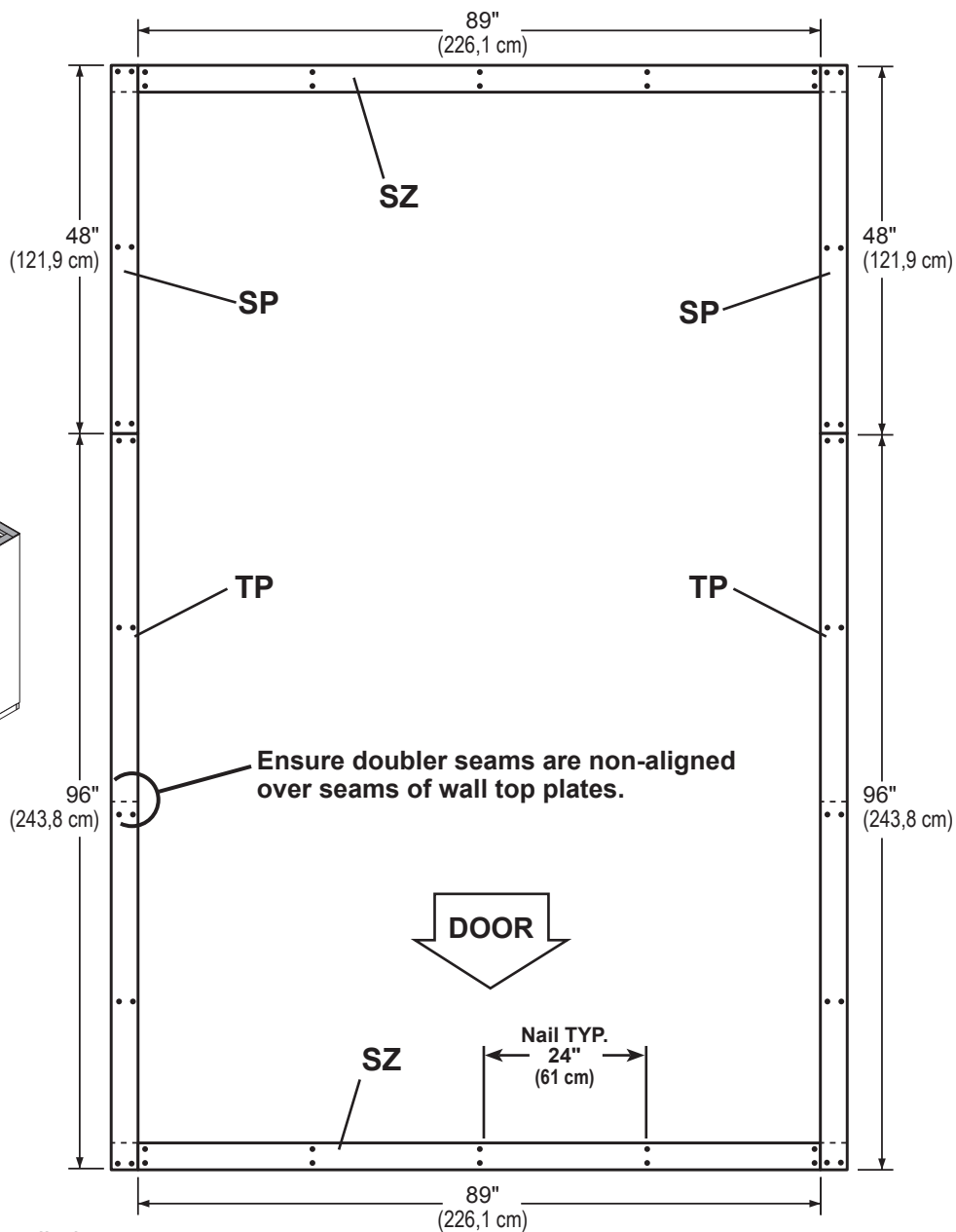
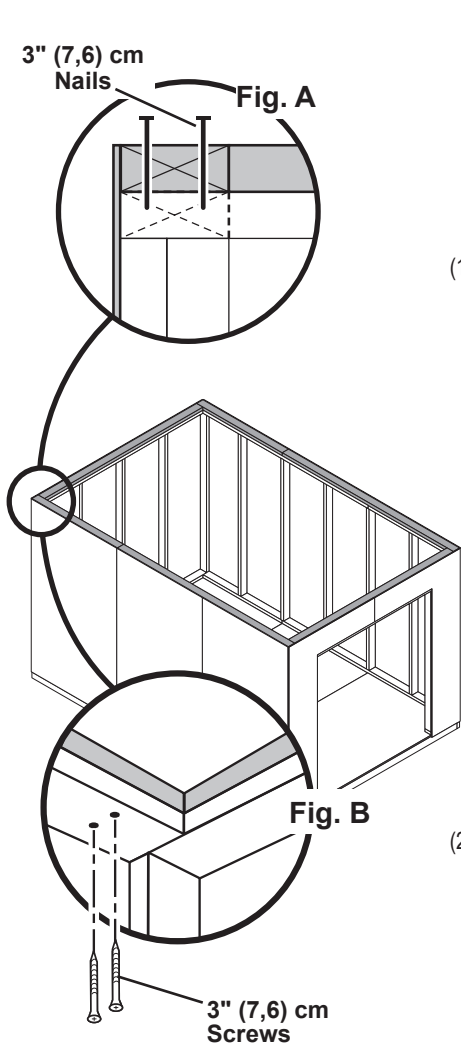

Your wall doublers are now installed.

GABLE PANELS

PARTS REQUIRED:

- x2 **UY**
2 x 4 x 6-1/2" (5,1 x 10,2 x 18,4 cm)
- x2 **CQA**
2 x 4 x 4" (5,1 x 10,2 x 10,2 cm)

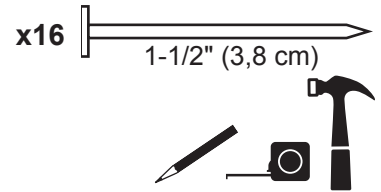
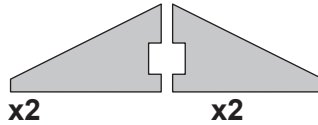

Install all panels with the primed side facing up.

Build 2 gable panel assemblies.

✓ BEGIN

- 1 Place left gable panel on **UY** and **CQA**.
Secure with 1-1/2" nails, as shown.

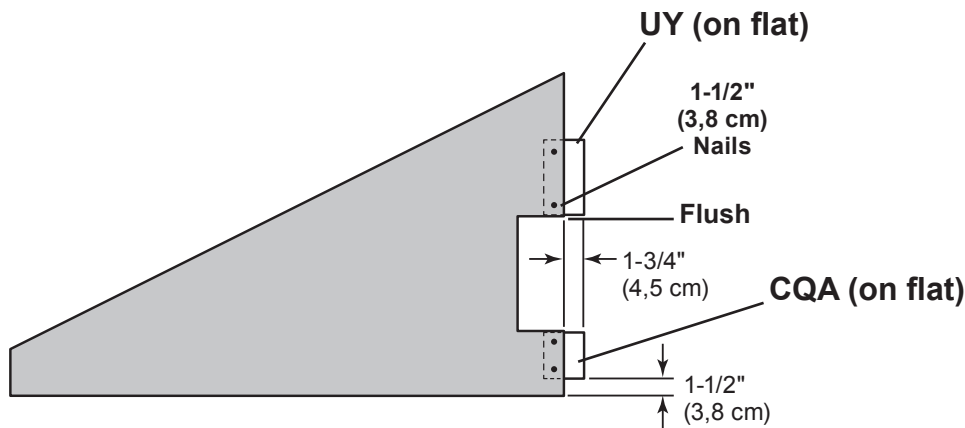

- 3 Place right gable panel on **UY** and **CQA**.
Secure with 1-1/2" nails, as shown.

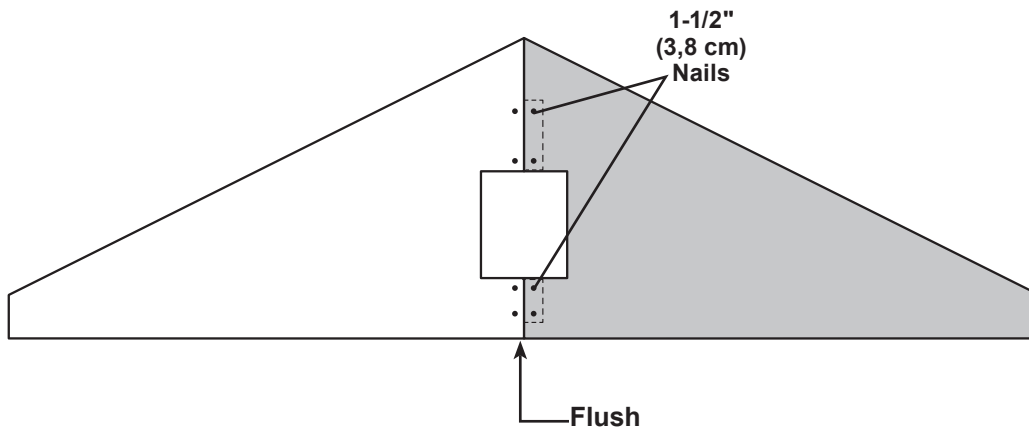

Repeat steps to build the 2nd gable assembly.



Your (2) gable assemblies are completed.

GABLE OVERHANG FRAMES

PARTS REQUIRED:

x12 **CLA**

2 x 4 x 4-7/8" (5,1 x 10,2 x 12,4 cm)

x8 **CMA**

2 x 4 x 61-7/8" (5,1 x 10,2 x 157,2 cm)

x56  3" (7,6 cm)

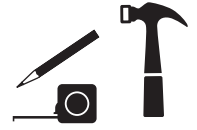

Build 4 gable overhang frames.

✓ **BEGIN**

- 1 Arrange, measure and mark locations of (2) **CLA**, (**Fig. A**).
Place **CMA** on top. Secure with 3" screws, as shown.
Ensure parts are flush along edges.

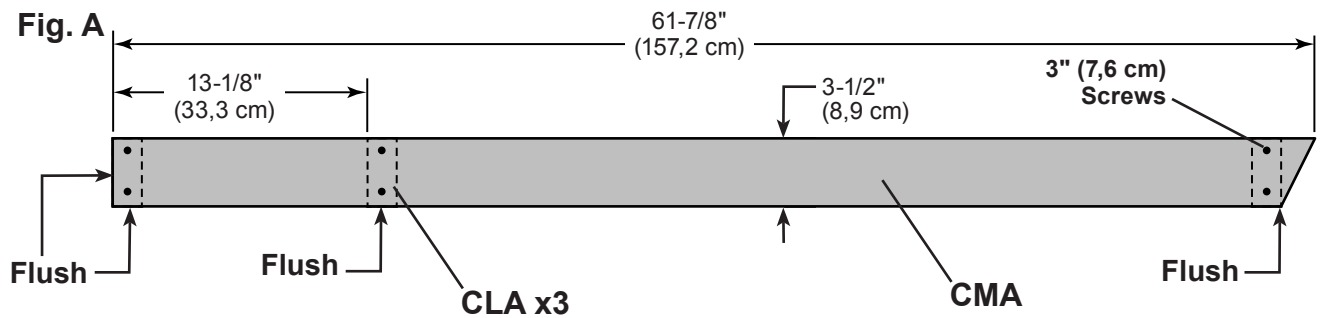
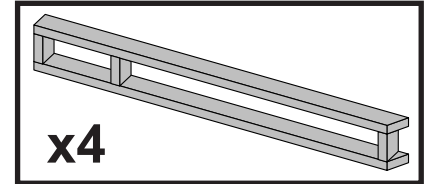

- 2 Flip over gable frame sub-assembly and attach **CMA** to (3) **CLA** with 3" screws (**Fig. C**).

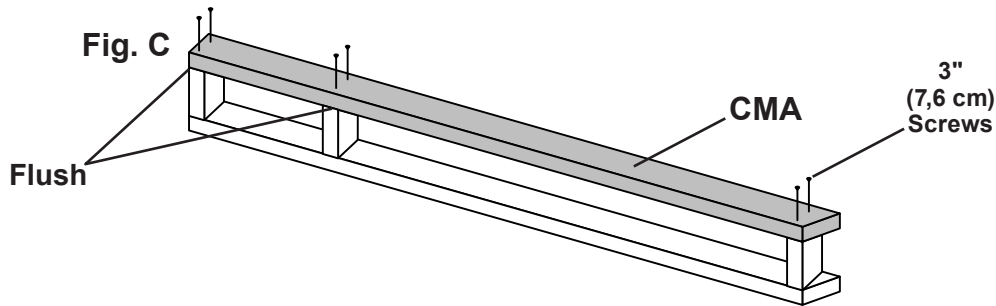

Repeat steps to build (3) additional gable frame sub-assemblies.

- 3 To complete gable overhang frame, join (2) sub-assemblies together with 3" screws angled, as shown (**Fig. D**).

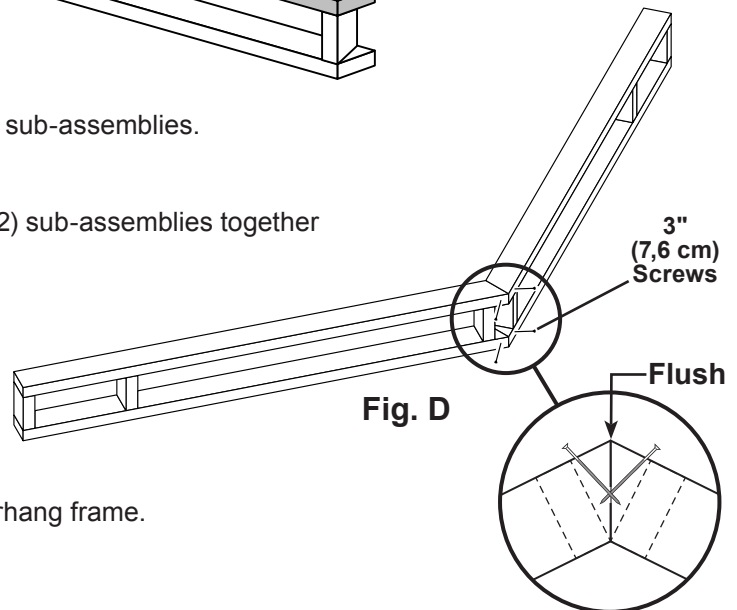

Repeat STEP 3 to assemble the 2nd gable overhang frame.

GABLE UNITS

PARTS REQUIRED:

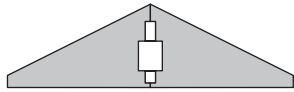

x2 Gable Assemblies

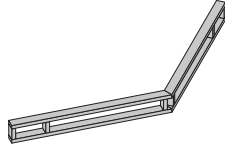

x2 Overhang Frames

x32 1-5/8" (4,1 cm)

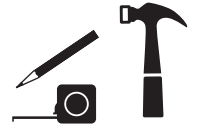

Arrange gable and ladder assemblies as shown (Fig. E). You will build 2 gable units.

- 4 Ensure gable panels are flush at peak of ladder and flush along top edge of ladder assembly. Secure with 1-5/8" screws as shown (Fig. E).

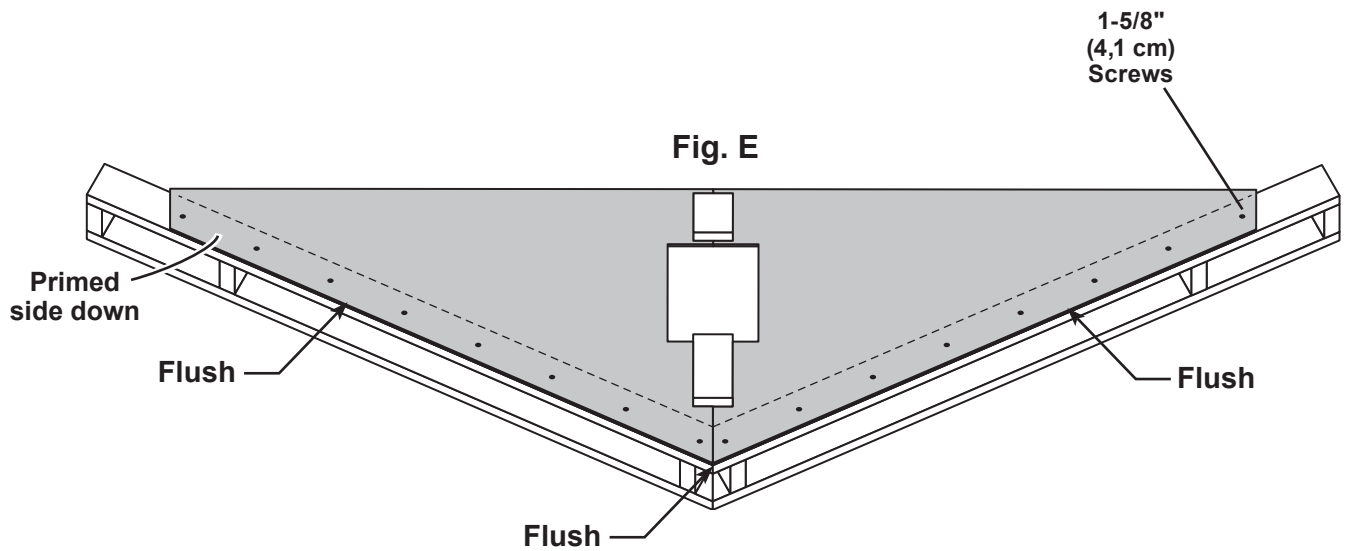

Repeat STEP 4 to build the 2nd gable unit.



You have finished building (2) gable units.

RAFTERS

PARTS REQUIRED:

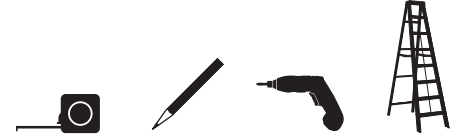
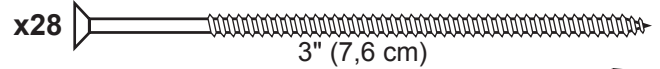
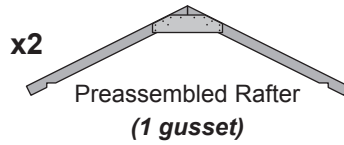
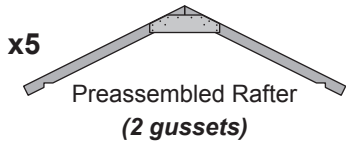

✓ BEGIN

- 1 Locate first rafter on top plate (Fig. A) aligned over studs at each side and tight to side wall (Fig. B, Fig C).
Rest notch on top plate.
- 2 Secure rafter to top plate with (2) 3" screws above notch (Fig. B, C).
- 3 Install remaining rafters on top plate, aligned over studs, as shown. Secure with 3" screws.

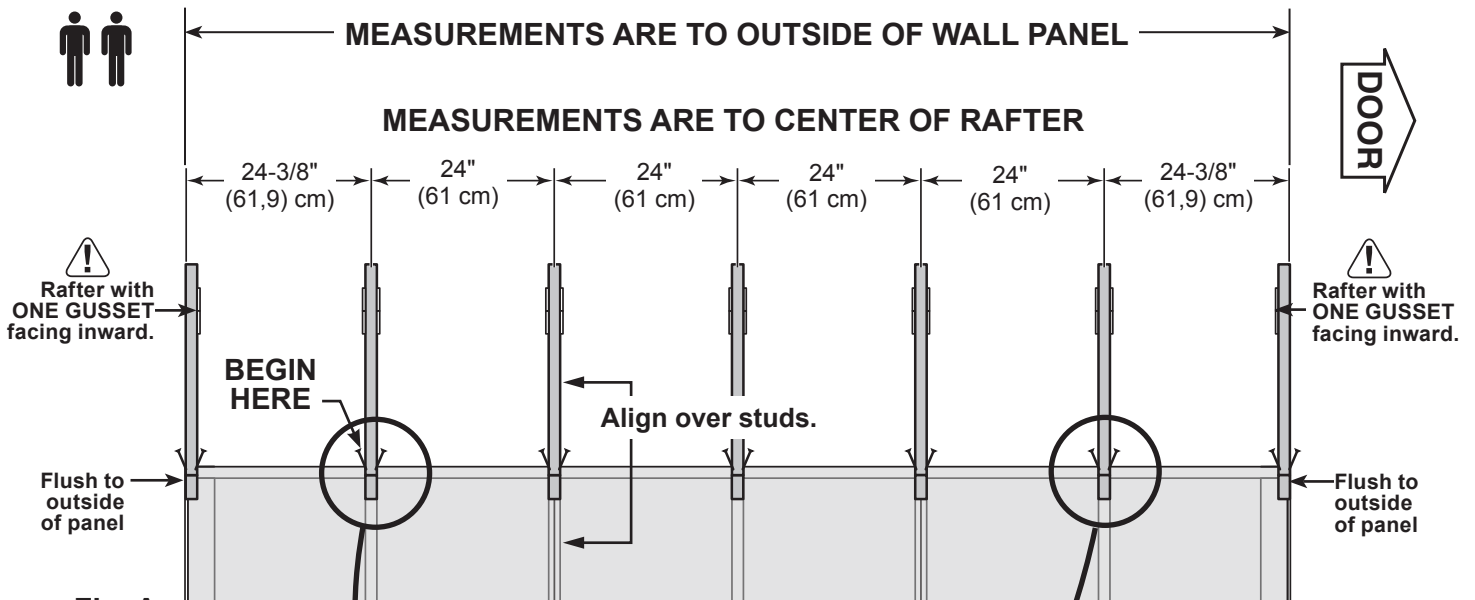

Fig. A

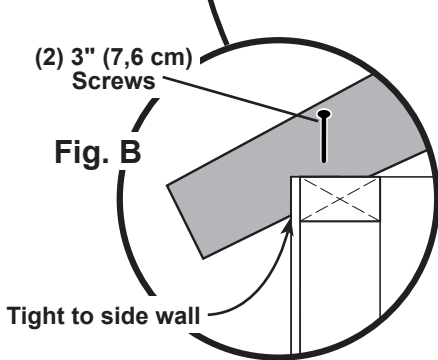

Fig. B

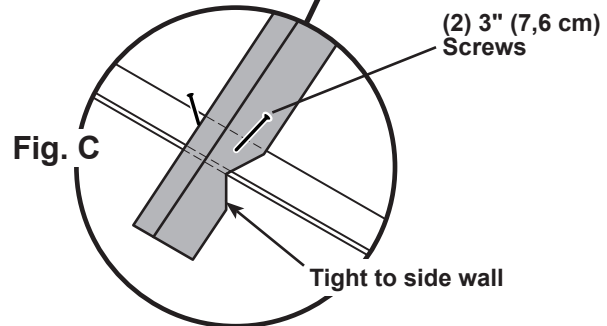

Fig. C



Your rafters are now installed.

GABLE UNITS

PARTS REQUIRED:

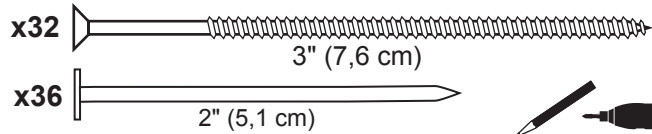
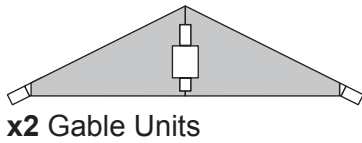

BEGIN



- 1 Measure 1-1/2" down from top plate and mark at each side as shown.
Set gable unit on wall doubler.
Hold gable unit secure with (1) 2" nail at each side as shown.

! BE SURE GABLE IS CENTERED ON WALL BEFORE NAILING. !

- 2 Continue nailing lower edge of panels into wall doubler. Secure with 2" nails spaced 6" apart, as shown
- 3 Working inside, secure gable unit with 3" screws into **CQA** and doubler at an angle, as shown (**Fig. B**).

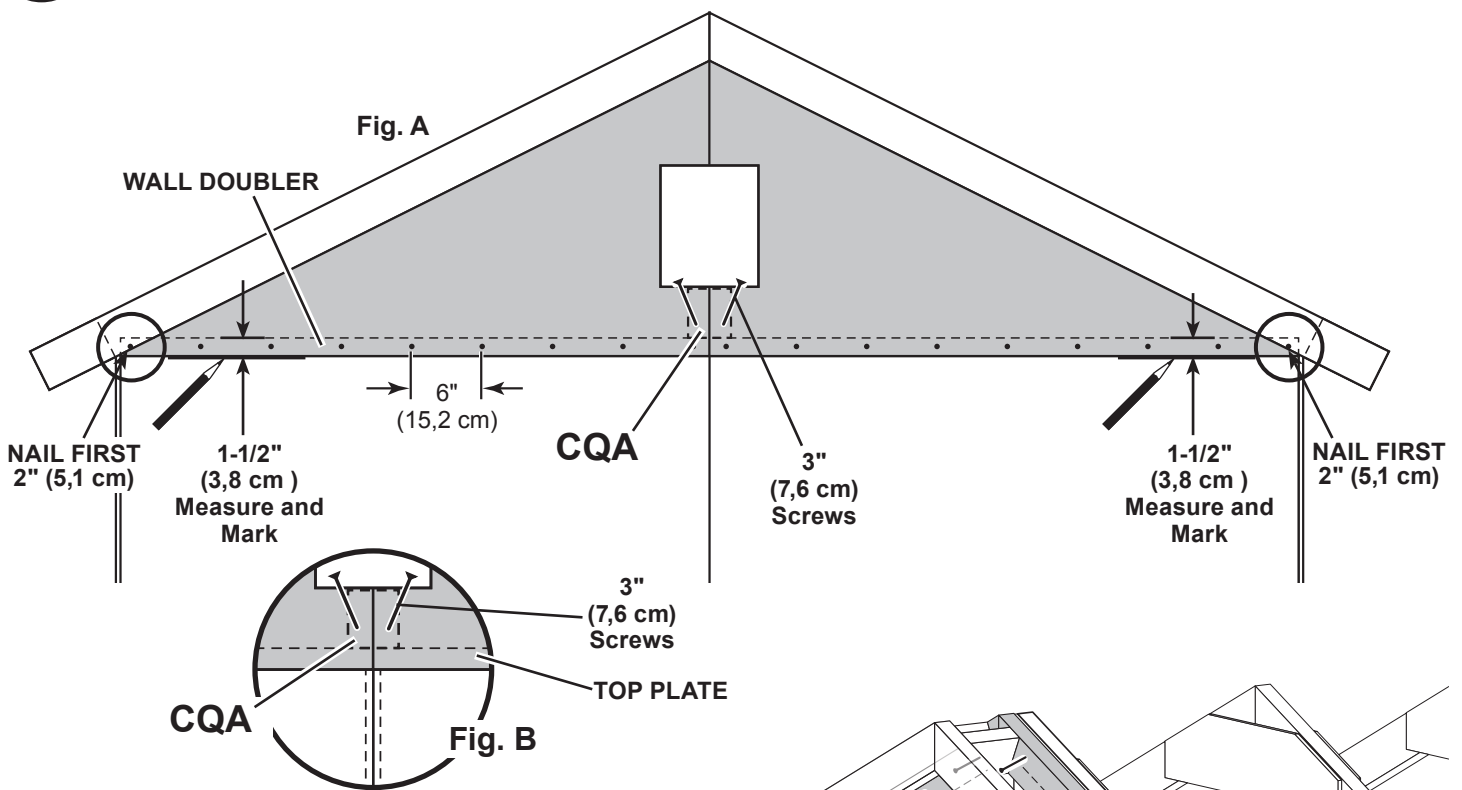

- 4 Secure gable unit framing to end rafter with 3" screws, as shown (**Fig. C**)

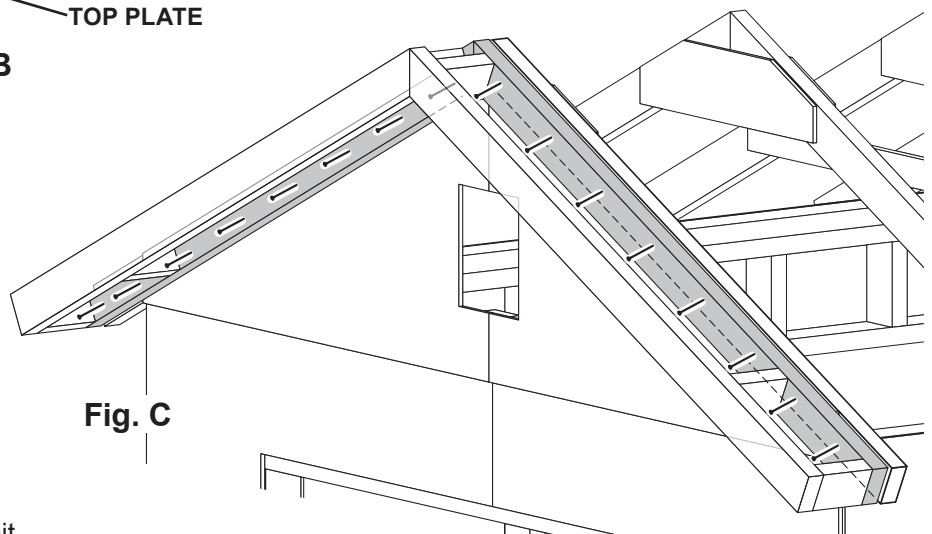

Repeat steps to install back gable unit.



Your gable units are now installed.

ROOF PANELS

PARTS REQUIRED:

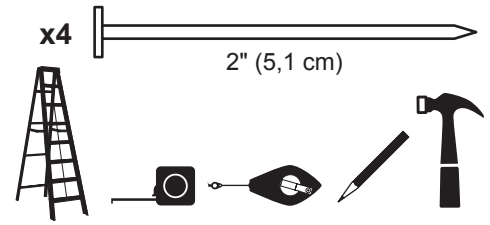
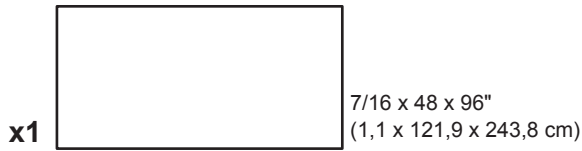

 Roof panels may cause serious injury until securely fastened.
Note: Install all roof panels with the rough side up (painted grid lines).



✓ **BEGIN**
1

Install a 48"x 96" roof panel with a 3/4" measurement on the 5th rafter (**Fig A**), and flush to the rafter end (**Fig. B**).

Secure panel with 2" nails in the corners.

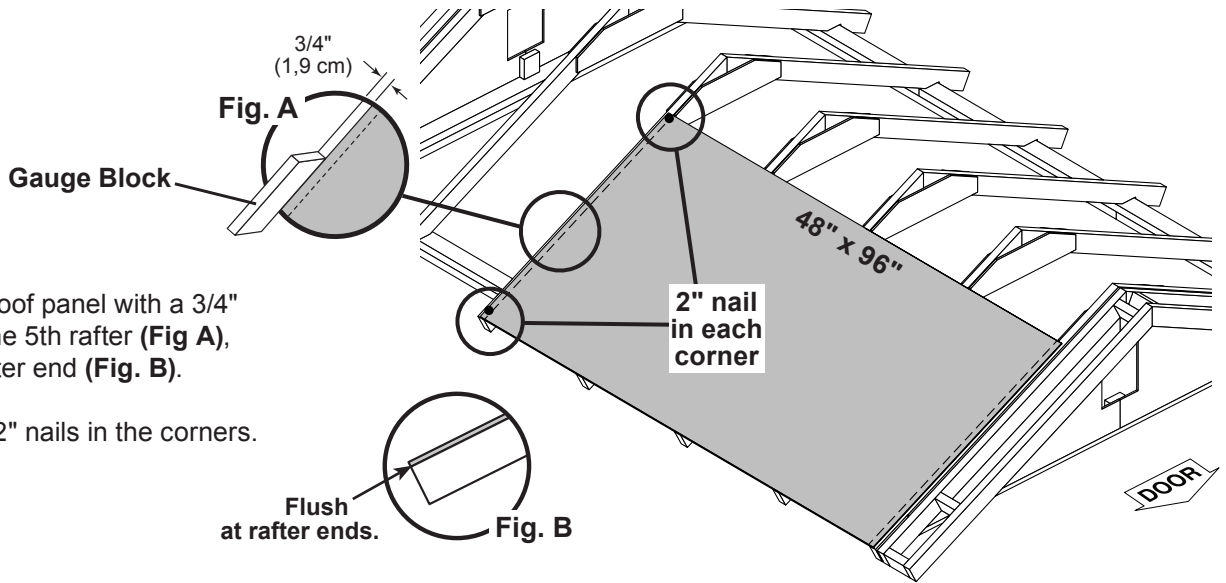

2

Move to the opposite end. Using the long edge of the panel as a lever, move the panel side-to-side until the corner is flush to the rafter end (**Fig. B**).

Move gable end rafter edge until it is 3/8" from the panel (**Fig. C**).

Secure panel with 2" nails in the corners.

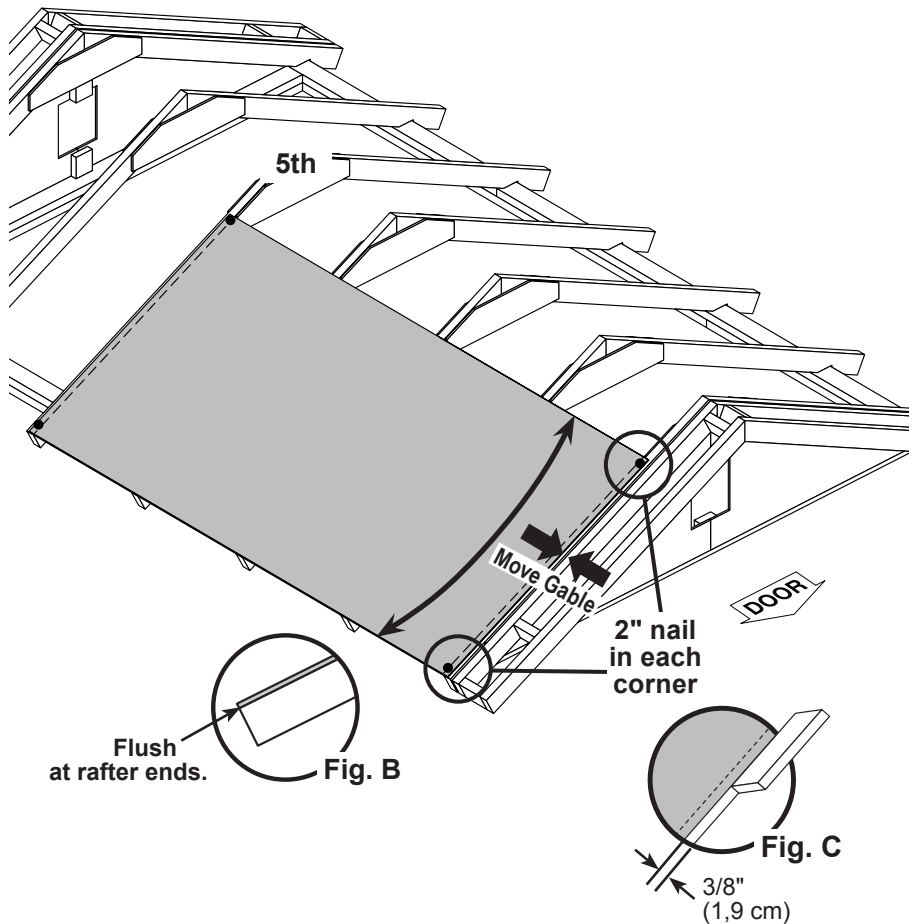

ROOF PANELS

PARTS REQUIRED:

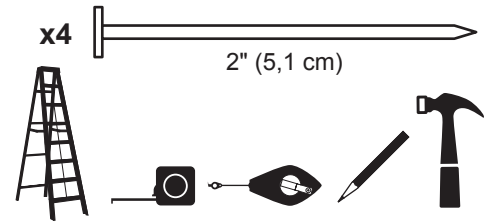
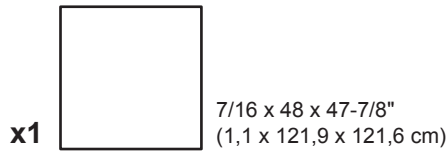

3

Install next 48" x 47-7/8" roof panel flush to the installed panel and flush to the rafter end (**Fig. B**).

Secure panel with (1) 2" nail in each corner.

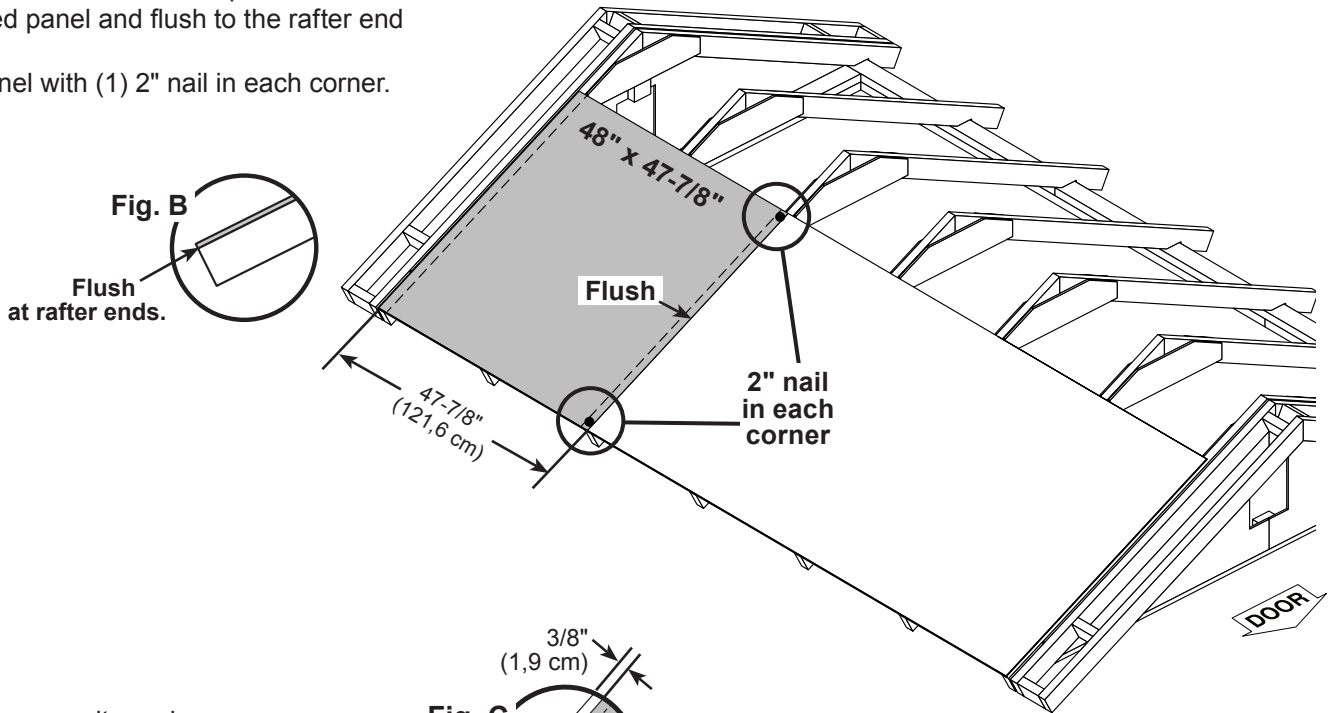

4

Move to the opposite end.

Using the unsecured end of the panel as a lever, move the panel side-to-side until the corner is flush to the rafter end (**Fig. B**).

Move gable end rafter edge until it is 3/8" from the panel (**Fig. C**).

Secure panel with 2" nails in the corners.

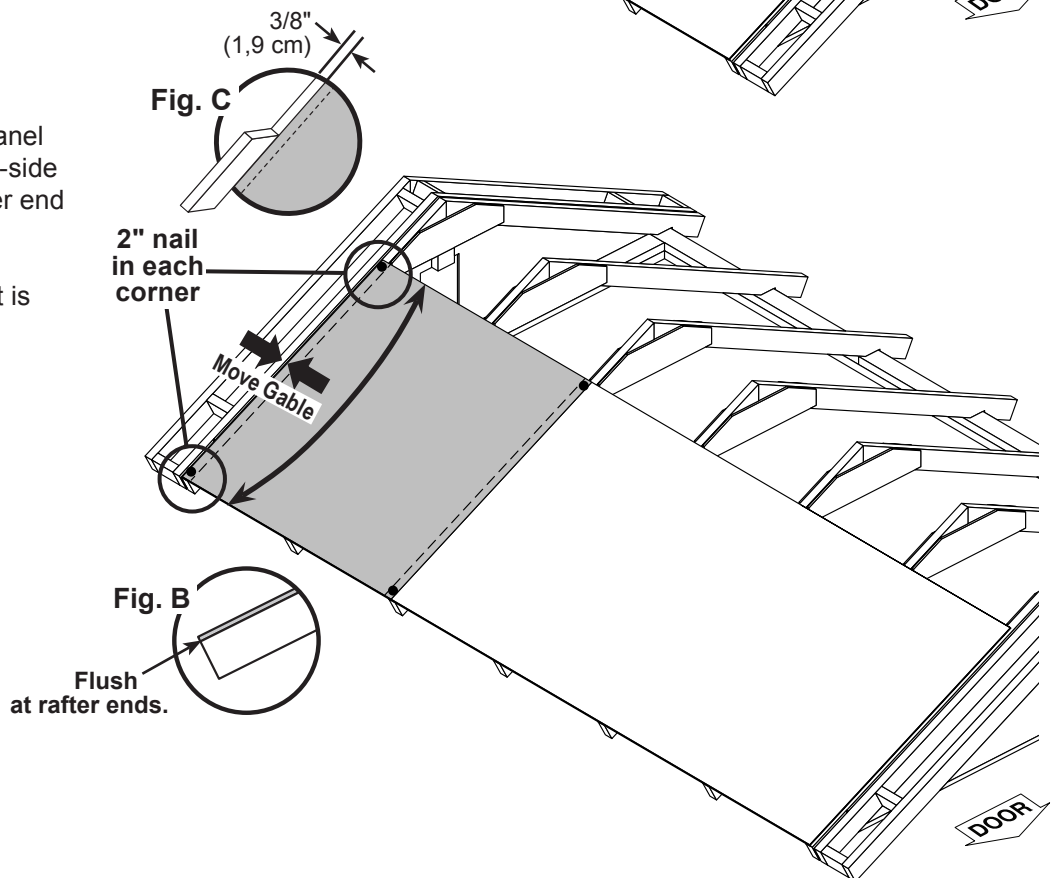

ROOF PANELS

PARTS REQUIRED:



5

Place a **13-7/8" x 96"** upper roof panel flush to lower panel.

Ensure 3/4" measurement on the rafter (**Fig. A**).

Secure the panel with 2" nails in each corner.

6

Place a **13-7/8" x 48"** upper roof panel flush to installed panels.

Secure the panel with 2" nails in each corner.

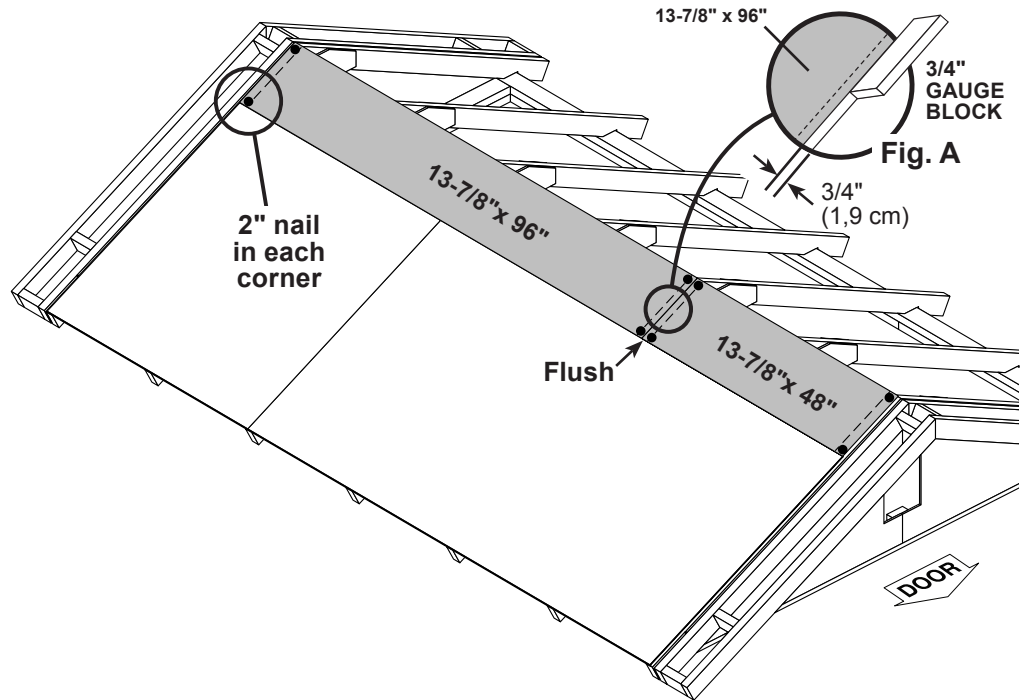

7

Maintain spacing between the center of the rafters for the lower panels (**Fig. D**).

Secure panels with (1) 2" nail into the rafters, as shown.

Move to the top panels and keep spacing between the center of the rafters.

Secure panels with (1) 2" nail into the rafters.

Fig. D

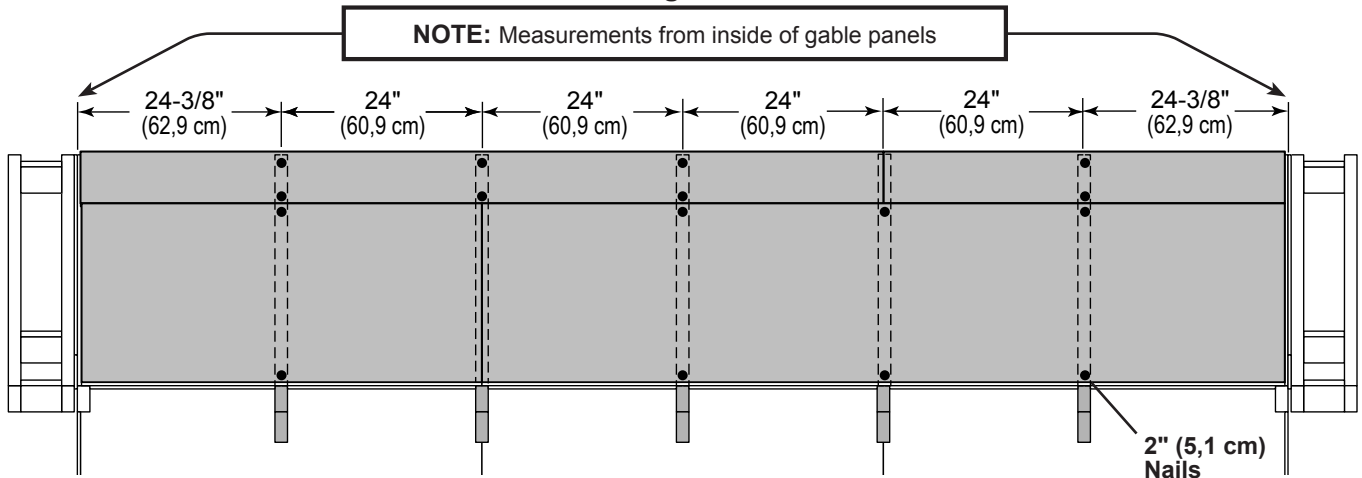

ROOF PANELS

PARTS REQUIRED:

x2  7/16 x 13-7/8 x 8-1/2"
(1,1 x 35,2 x 21,6 cm)

x2  7/16 x 48 x 8-1/2"
(1,1 x 121,9 x 21,6 cm)

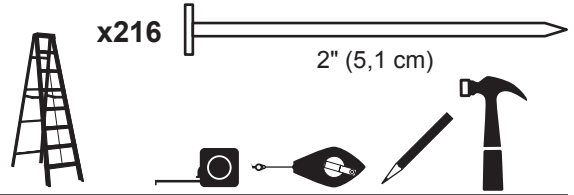

8

Place 8-1/2" x 13-7/8" roof panel flush to the outside of gable framing and flush to the lower edge of the gable frame (Fig. E).

Secure the panel with 2" nails in each corner.

Place 8-1/2" x 48" roof panels flush to the outside of gable framing and flush to the installed lower panel.

Secure the panel with 2" nails in each corner.

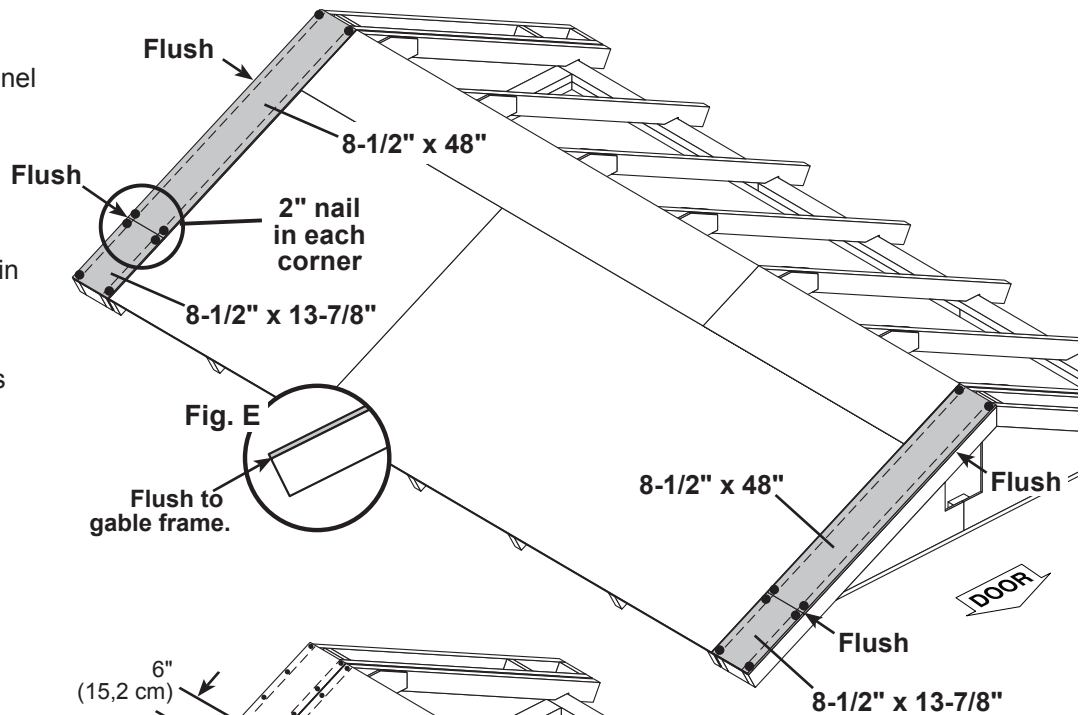

9

Secure roof panels with 2" nails spaced 6" apart on edges and 12" apart inside panel.

Repeat all steps to install roof panels on the opposite side.

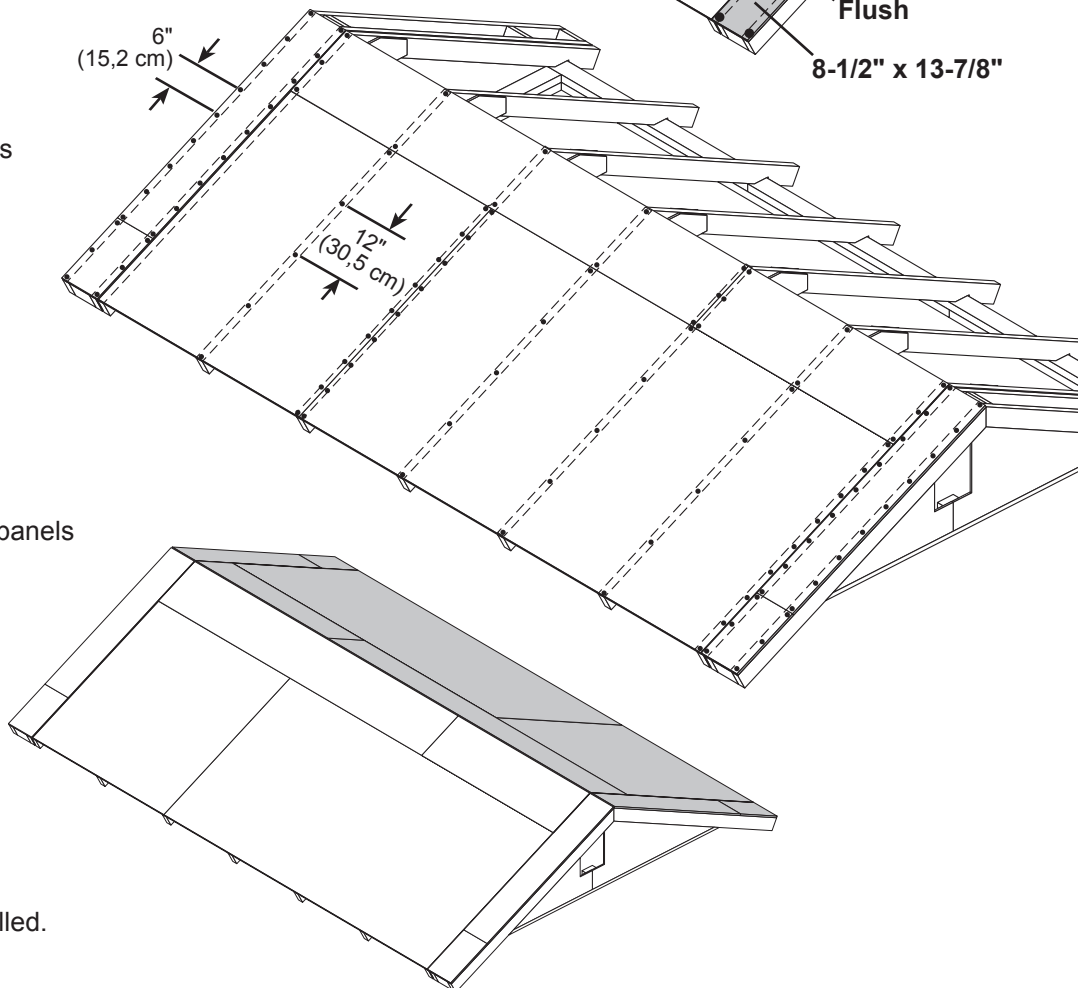

Your roof panels are now installed.

GABLE END SOFFITS

PARTS REQUIRED:

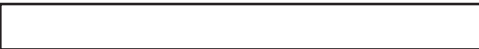
x4 
 3/8 x 7-7/8 x 59-15/16" (1 x 20 x 152,2 cm)

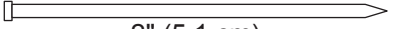
x48 
 2" (5,1 cm)

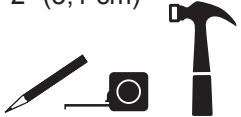

Install all panels with the primed side facing down.

✓ BEGIN

- 1 Position right **59-15/16"** overhang board flush to front wall (**Fig A**) and gable panel seam (**Fig B**). Secure with (12) 2" finish nails.

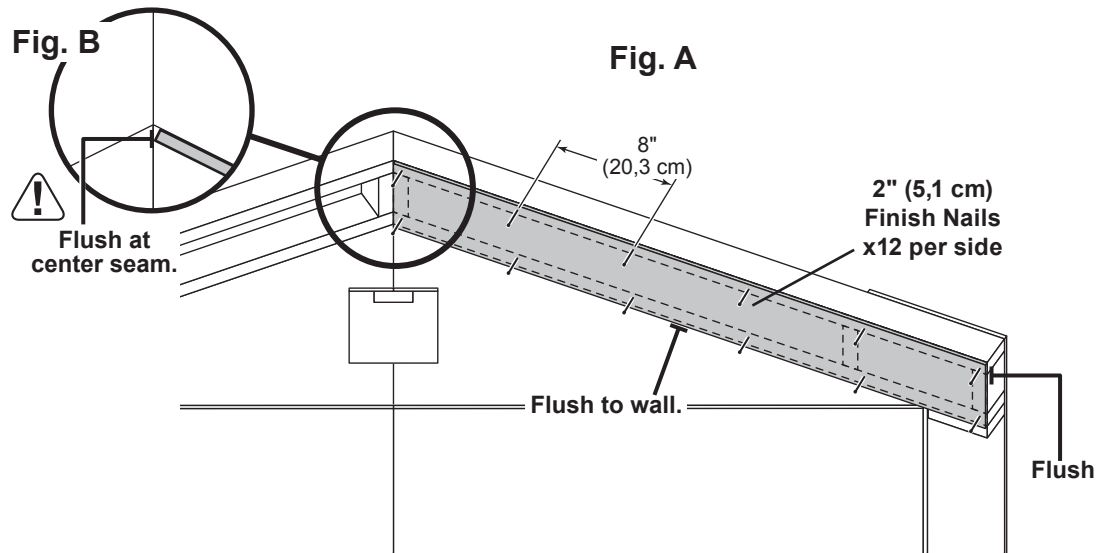

- 2 Position left **59-15/16"** overhang board flush to front wall gable end (**Fig C**), and right overhang board (**Fig. D**). Secure with (12) 2" finish nails.

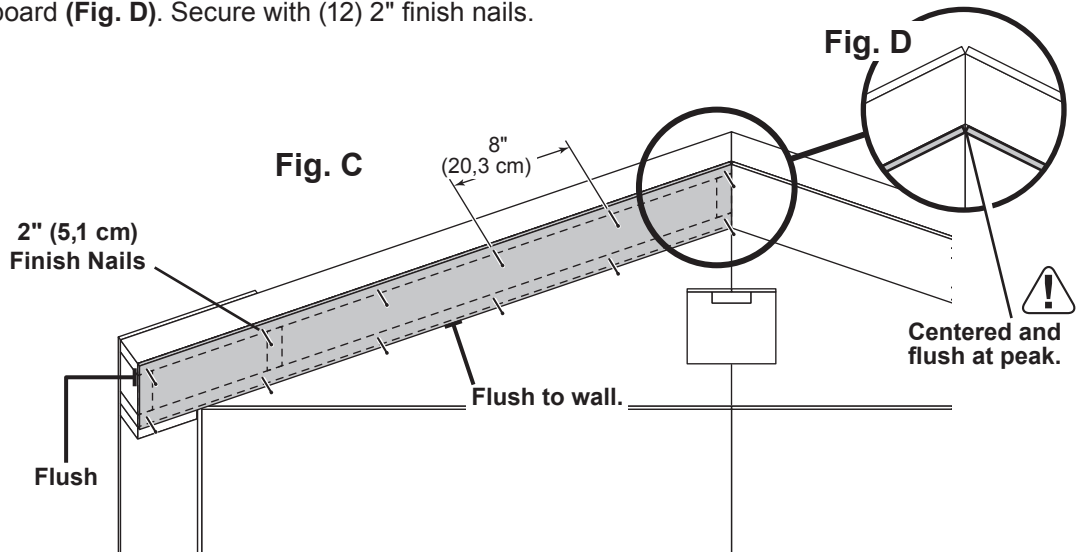

Repeat steps to attach soffit boards on the opposite side.



Your gable soffit panels are now installed.

EAVE SIDE SOFFITS

PARTS REQUIRED:

x4 
3/8 x 5-7/8 x 73" (1 x 14,9 x 185,3 cm)

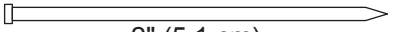
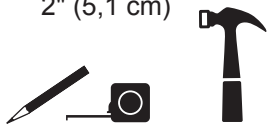
x32 
2" (5,1 cm) 

Install all panels with the primed side facing down.

✓ **BEGIN**

- 1 Position 73" soffit boards flush to rafter ends and seam (Fig A).
Secure with 2" finish nails, (2) nails in each rafter and (4) nails angled at the seam (Fig. C).
****Eave pieces may need to be trimmed to fit****

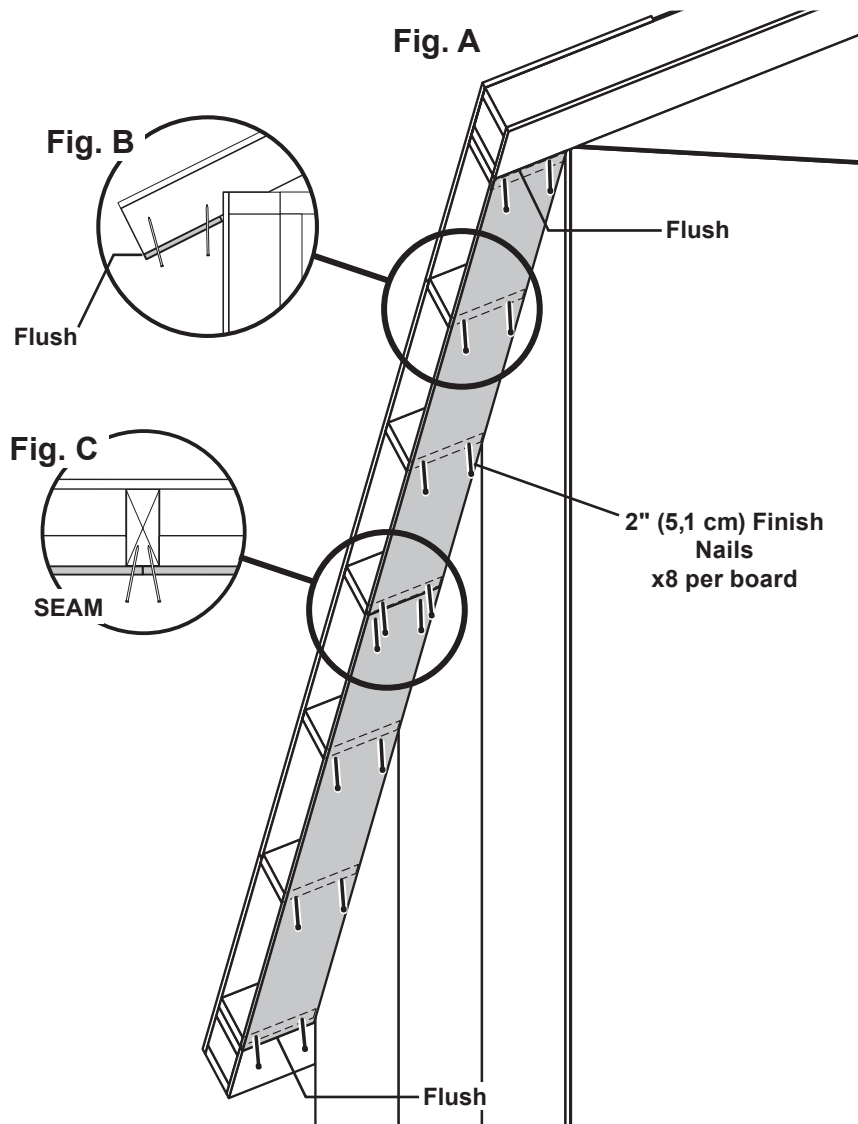

Repeat steps to install eave side soffit boards on the opposite side.



Your eave side soffit panels are now installed.

GABLE FASCIA

PARTS REQUIRED:

x2 
3/8 x 4-3/4 x 62-7/16" (1 x 12,1 x 158,6 cm)

x2 
3/8 x 4-3/4 x 62-7/16" (1 x 12,1 x 158,6 cm)

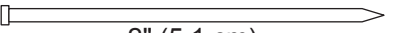
x32 
2" (5,1 cm)



Install all panels with the primed side facing out.

✓ **BEGIN**

- 1 Position fascia flush to peak and roof panels as shown (Fig. A, Fig B).
Secure with 2" finish nails spaced evenly, as shown.

Repeat steps to install gable fascia boards on the opposite side.

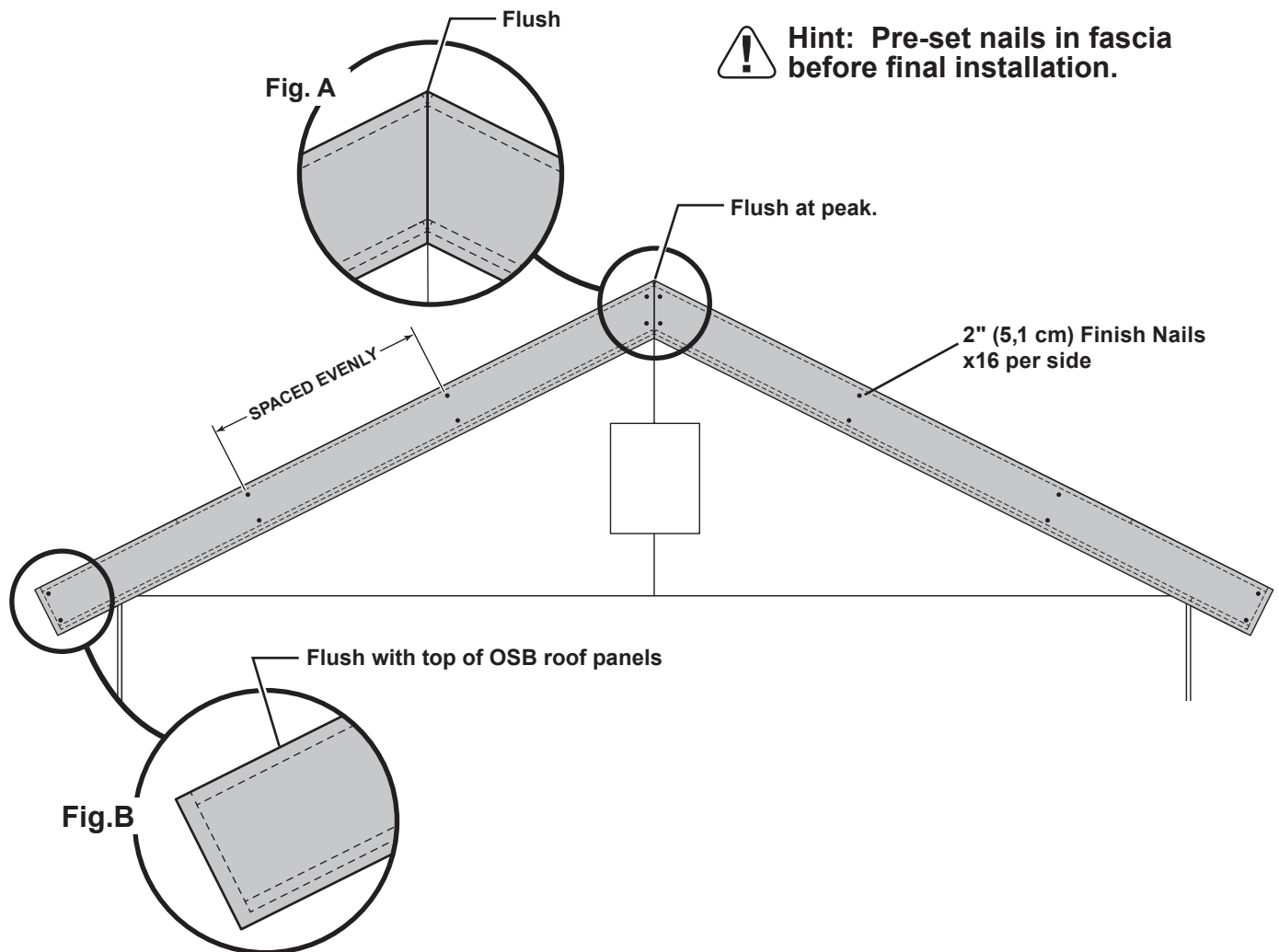

Repeat steps to install fascia boards on the other gable end.



Your gable fascia boards are now installed.

EAVE SIDE FASCIA

PARTS REQUIRED:

x4 
3/8 x 4-3/4 x 80-5/8" (1 x 12,1 x 204,8 cm)

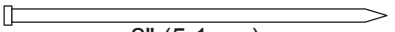
x32 
2" (5,1 cm)



Install all panels with the primed side facing out.

✓ **BEGIN**

- 1 Position (2) 4-3/4" x 80-5/8" fascia boards flush with roof panels and seam, as shown (Fig. A). Secure with 2" finish nails, (2) nails in each rafter end, and (4) nails angled at the seam.

****Fascia may need to be trimmed to fit****

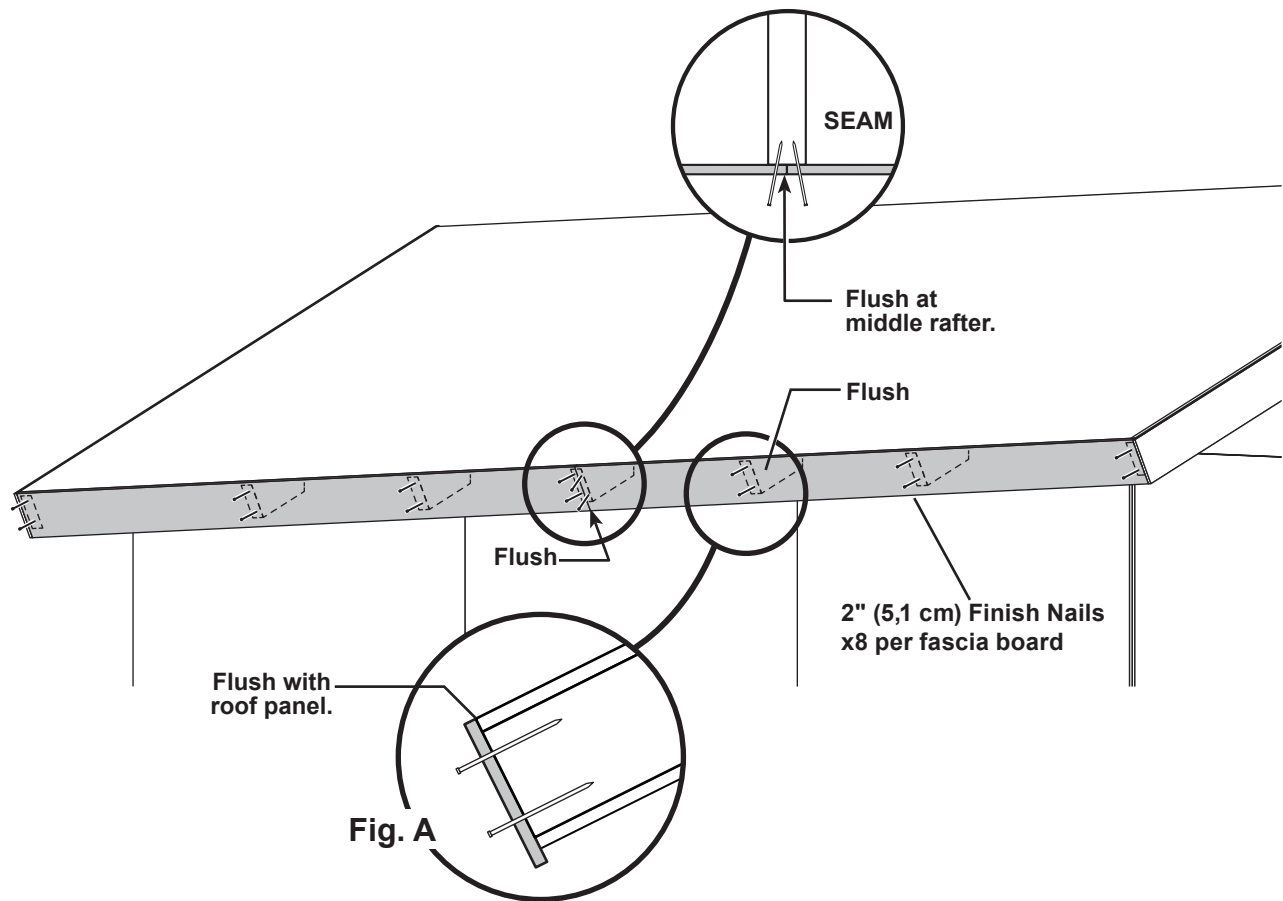

Repeat steps to install fascia on the opposite eave.



Your eave side fascia boards are now installed.

DOORS

PARTS REQUIRED:

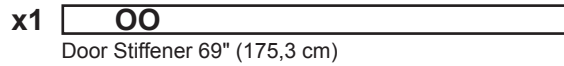
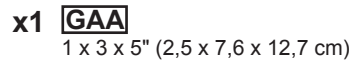
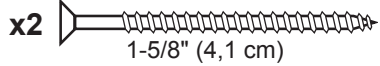
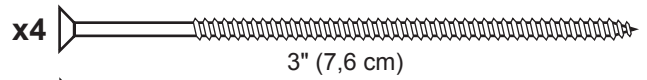
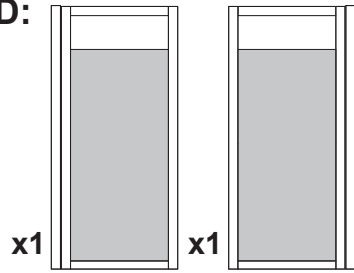

✓ BEGIN

- 1 Arrange parts as shown on flat surface. **⚠ 3/8" offset is to top.**
Look for red (right) and green (left) on hinge board.
- 2 Attach temporary support **OO** with 3" screws in middle and at ends, as shown.
- 3 Attach temporary support **GAA** with (2) 1-5/8" screws.

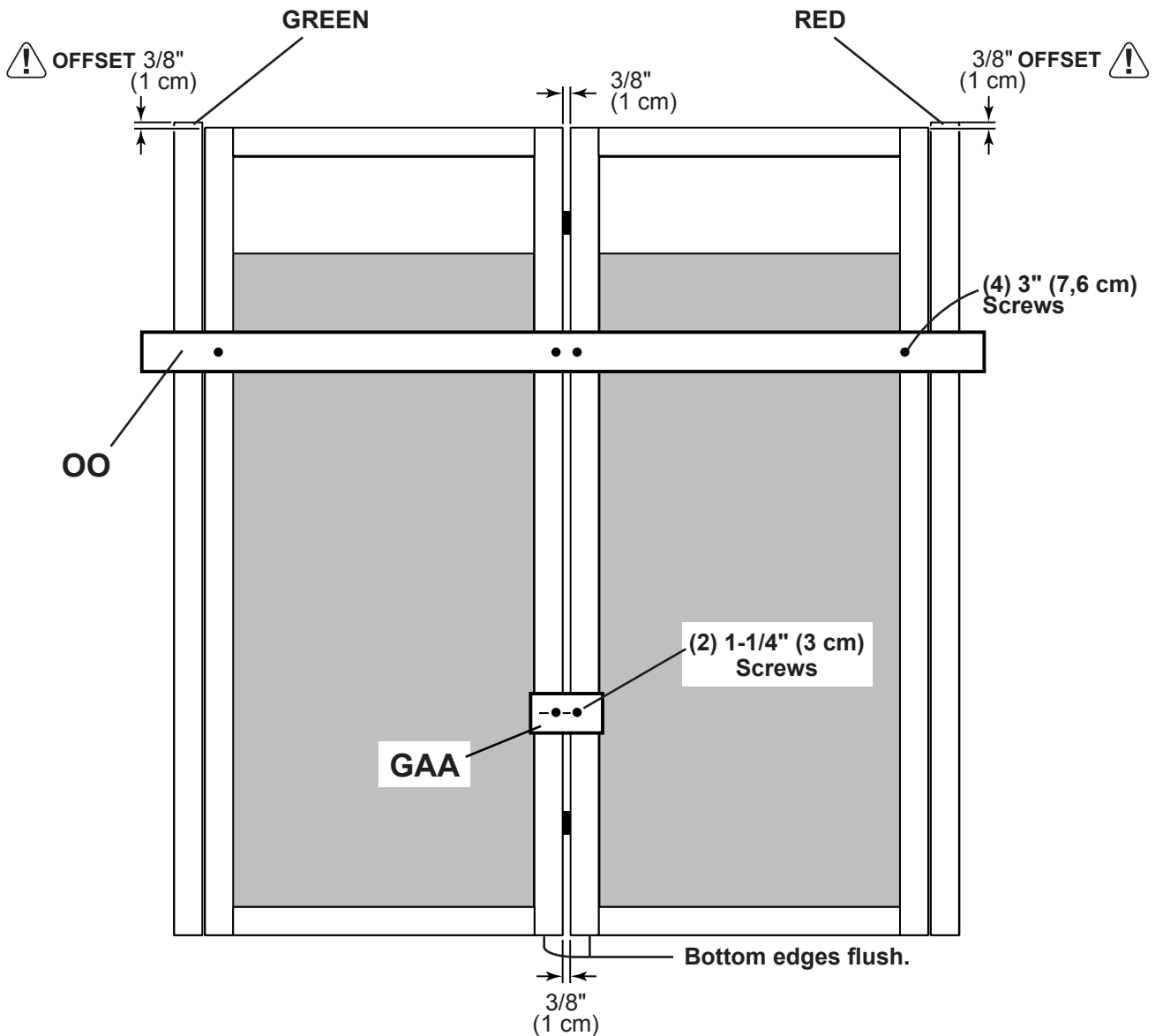

DOORS

PARTS REQUIRED:

x1 **OO**
69" Door Stiffener (175,3 cm)

x12 
3" (7,6 cm)



- 4 Install temporary support **OO** as a ledger board flush under wall panels for doors to rest on. Secure with (2) 3" screws (**Fig. A**).

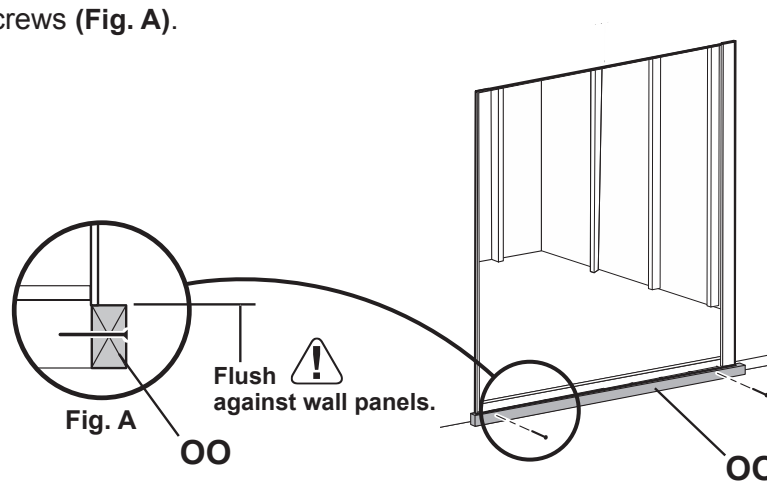

- 5 Center doors on panel seam, as shown (**Fig. B**). 

- 6 Screw hinge boards into wall supports and floor with (10) 3" screws, as shown.  Make sure screws go into framing and floor (**Fig. C, D**).

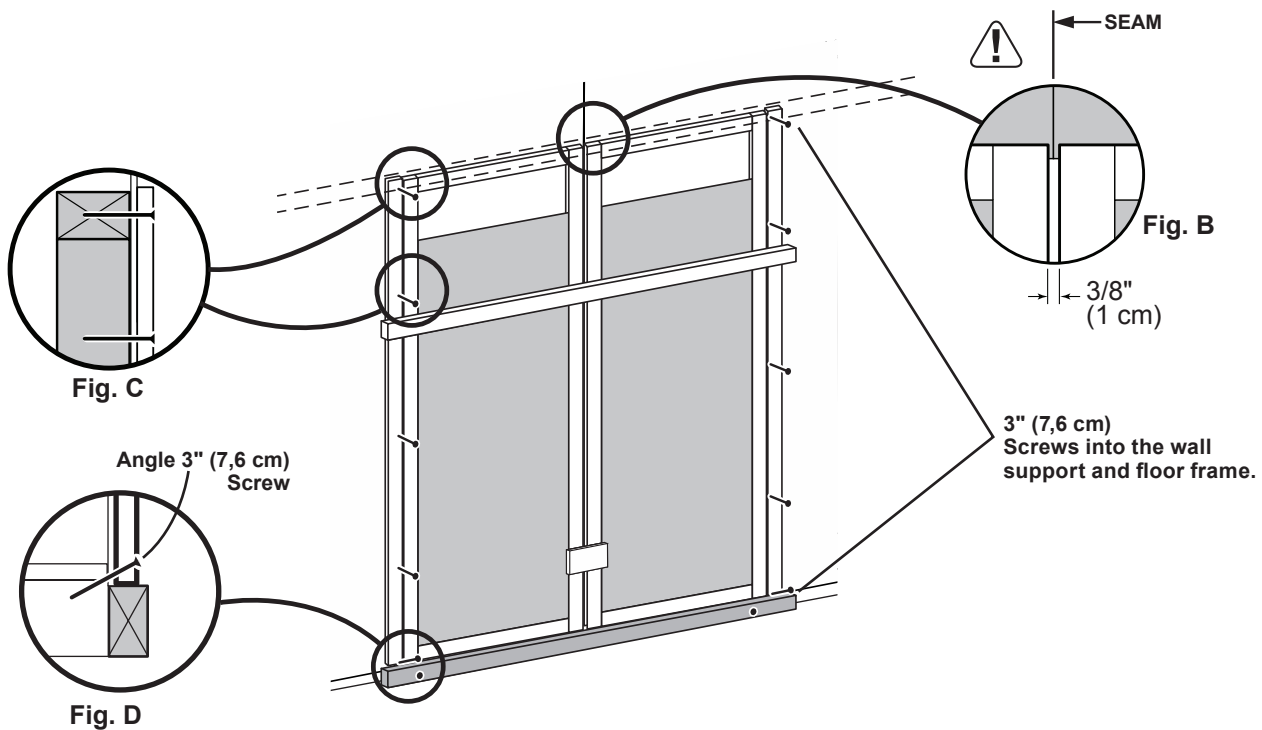

You have finished installing your doors.

Remove temporary support and ensure that the doors open properly.

DOOR TRIM and THRESHOLD

PARTS REQUIRED:

x4 **AH**
19/32 x 3 x 26-5/8" (1,5 x 7,6 x 67,6 cm)

x1 **ZJ**
19/32 x 3 x 72" (1,5 x 7,6 x 183 cm)

3/4" (1,9 cm) x11
Bagged seperately / special coating

x1 64" Metal Threshold

x5 2" (5,1 cm)

x56 3/4" (1,9 cm)

✓ BEGIN

- 1 Secure door trim from inside using 3/4" screws (Fig. A).
- 2 Secure two horizontal door rails **AH** with (4) 3/4" screws from behind to center of doors.
- 3 Reinforce the door trim with 3/4" screws through door panel into trim (Fig. A). Locate screws as shown (Fig. B).
- 4 Center trim **ZJ** over doors and secure using five 2" finish nails into wall framing.

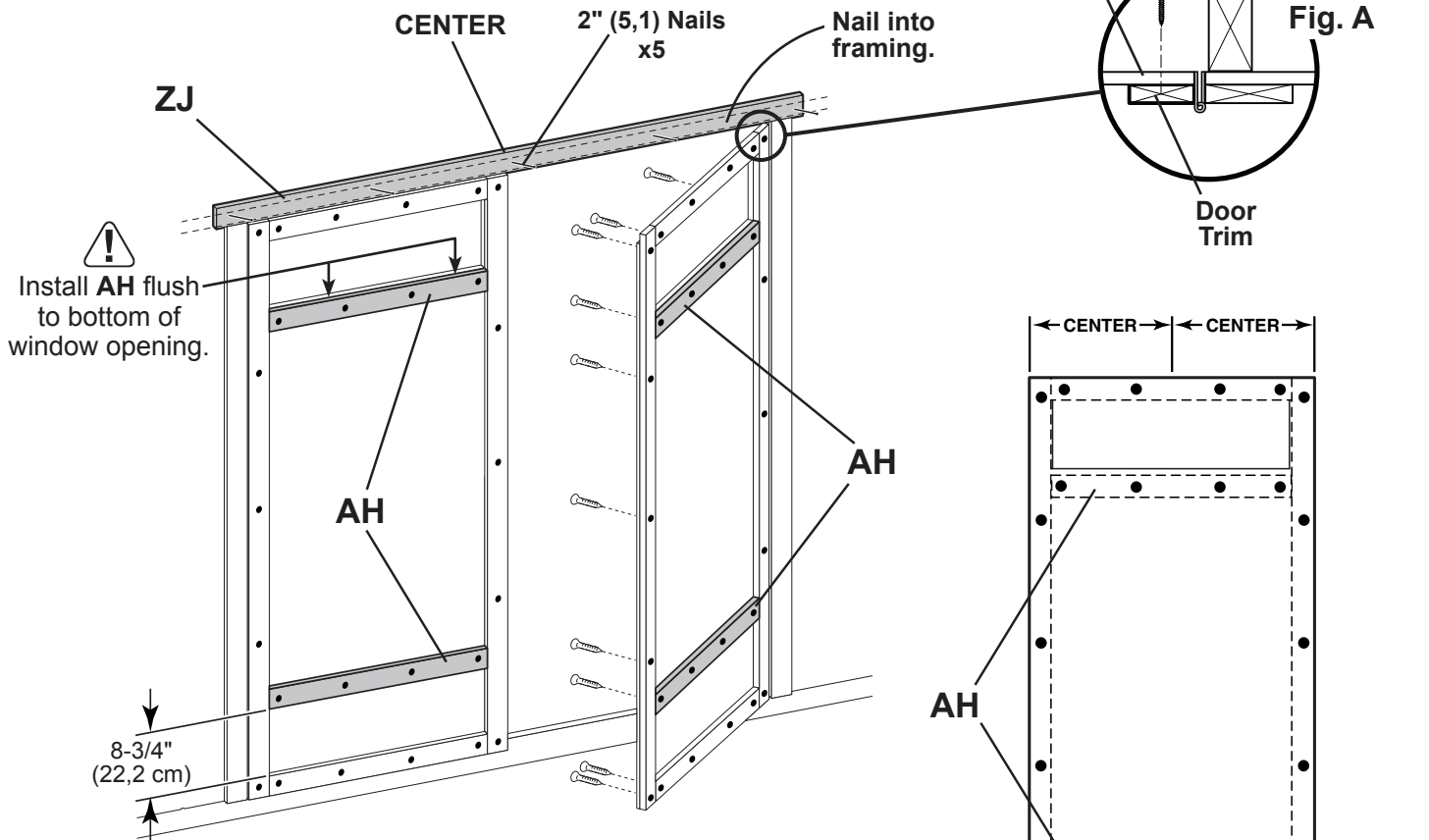

- 5 Center metal threshold between doors. secure using eleven 3/4" special coating screws (Fig. C).

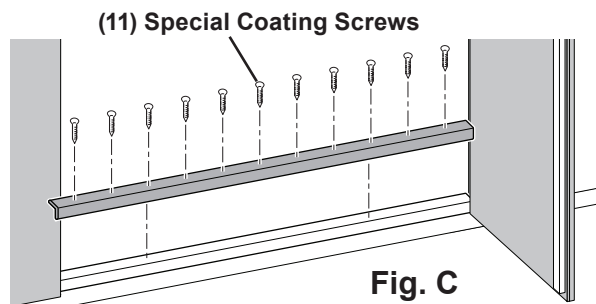

Your door and trim are now secured

DOOR TRANSOM WINDOWS

PARTS REQUIRED:

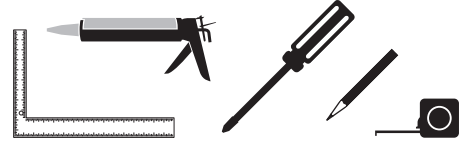
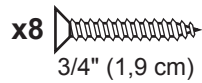
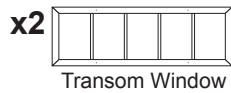

✓ BEGIN

- 1 Apply high quality exterior-grade caulk behind frame near edge before installing to seal window.

You must caulk completely around window frame and all exposed door panel edges and trim to validate your warranty. Use a paintable exterior rated caulk.

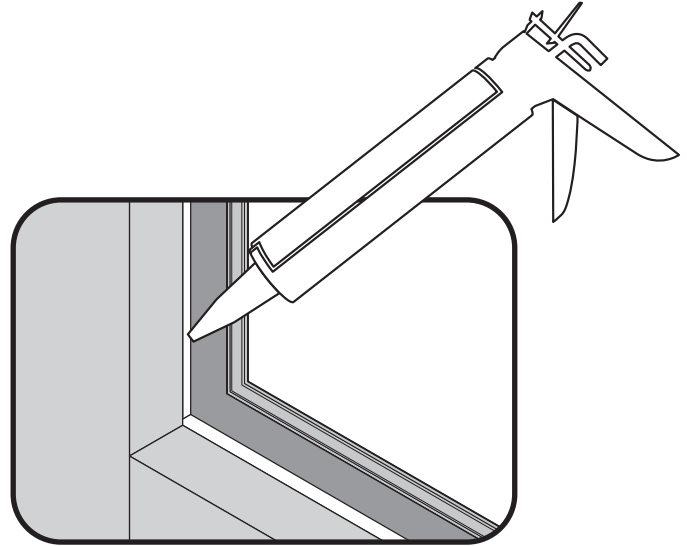

FRONT SIDE VIEW

- 2 From back side of door, measure 15-13/16" from inside edge of door. Mark center of window opening on door.

Position window in opening flush to bottom of window opening. Center window on mark.

Secure with (4) screws to secure each window.

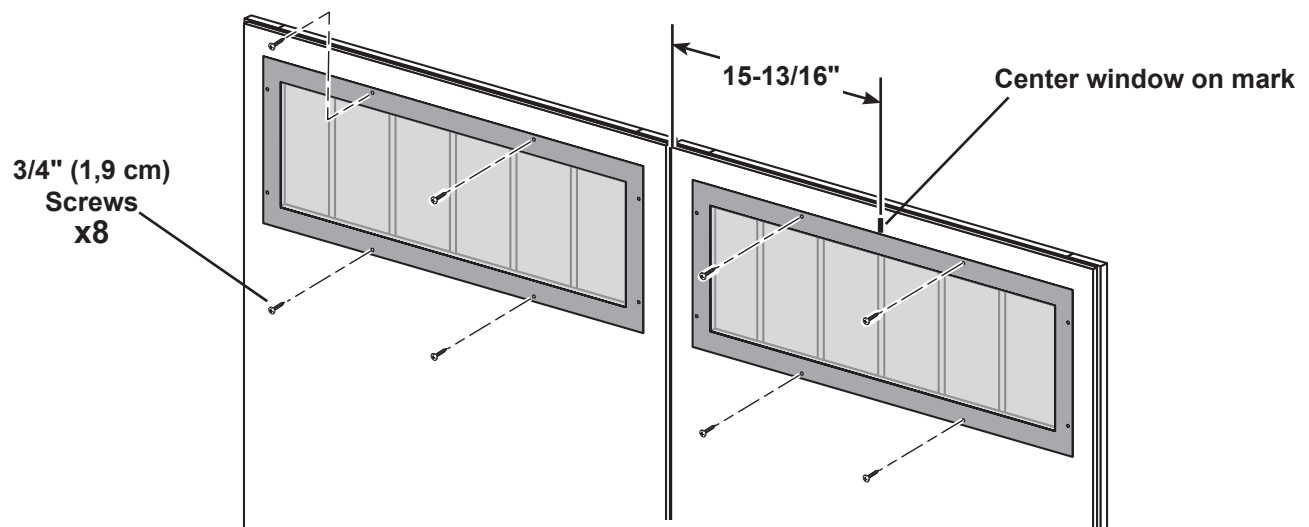

BACK SIDE OF DOORS



Your transom windows are installed.

DOOR STIFFENERS

PARTS REQUIRED:

x2  OO
69" Door Stiffener (175,3 cm)

x14 
2" (5,1 cm)





✓ BEGIN

- 1 Center OO vertically on the left door in the door opening flush with the edge of door (Fig. A).
- 2 Secure with (7) 2" screws through outside trim into OO (Fig. B)

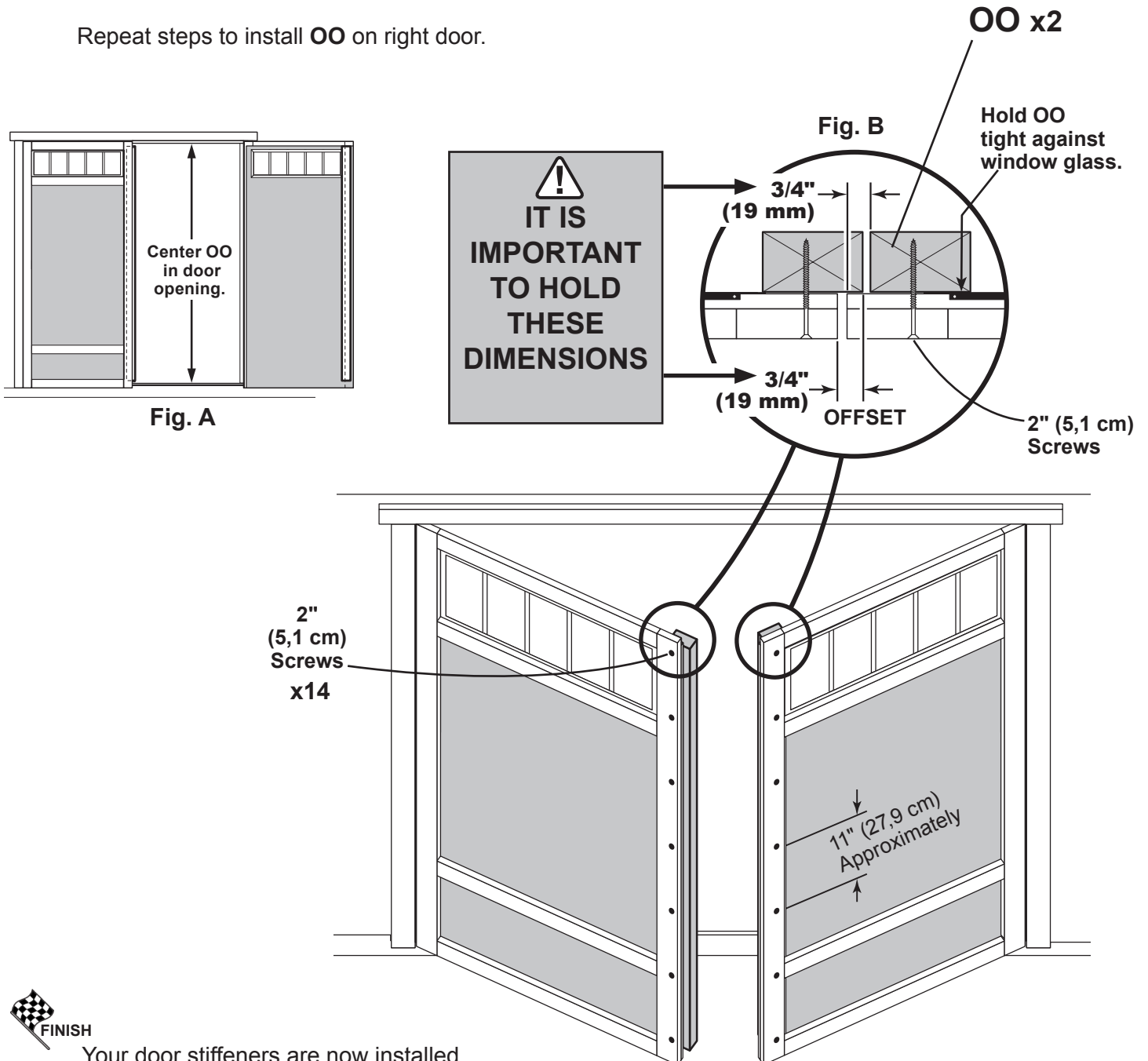
Repeat steps to install OO on right door.



DOOR HARDWARE

PARTS REQUIRED: x4 
 x12 
 1" (2,5 cm)



BEGIN

1 Measure and mark location of hole on outside of right door as shown (Fig. A).
 Pre-drill hole with 1/4" drill.

2 Re-drill hole with 1/2" drill (Fig. B).

 Keep drilled hole square to trim to avoid breaking edge of door stiffener **OO**.

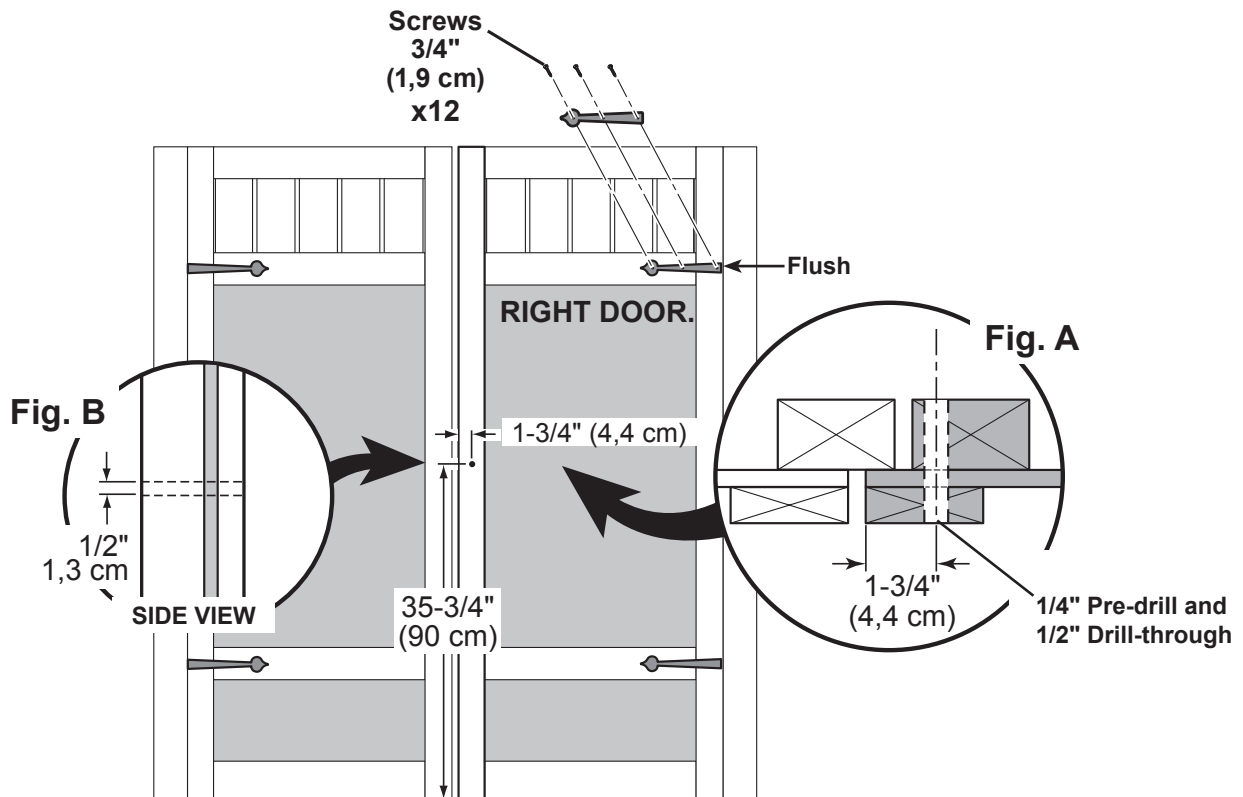

3 Install decorative hinges on horizontal trim and flush against hinge, as shown.



Your door is now prepared for handle installation.

DOOR HARDWARE

PARTS REQUIRED:

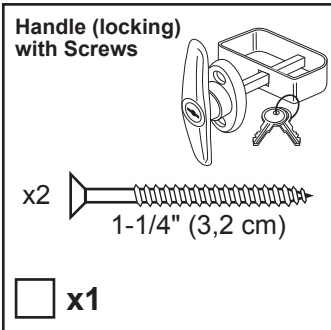

1/2" (13 mm) Drill Bit

1/4" (6 mm) Drill Bit

Secure handle with 1-1/4" screws, as shown.

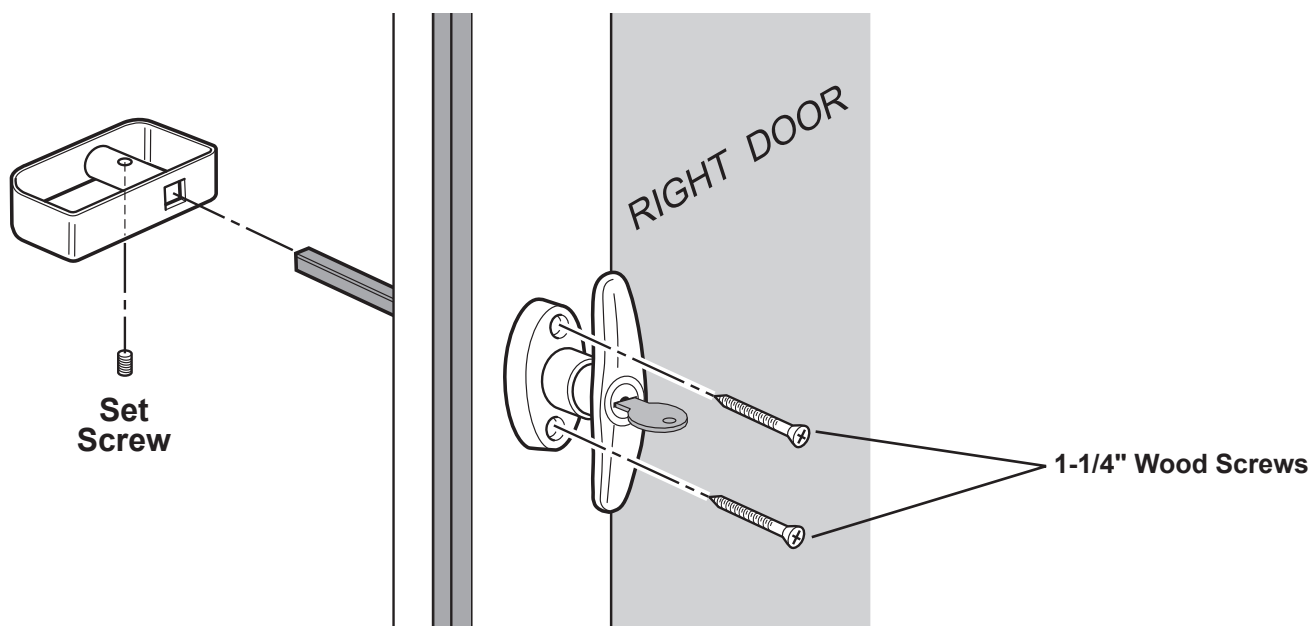

DOOR HARDWARE

PARTS REQUIRED:

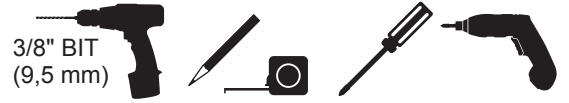
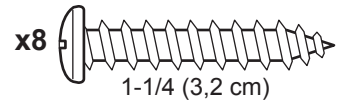
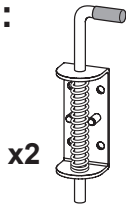

✓ BEGIN

- 1 Flush and center top spring bolt at the top of **OO** (Fig. A). Secure with (4) 1-1/4" screws.
Mark spring bolt pin location on over door frame. Drill a 1-1/2" deep hole using a 3/8" drill bit.

- 2 Flush and center bottom spring bolt to bottom of **OO** (Fig. B). Secure with (4) 1-1/4" screws.
Mark spring bolt pin location on floor.
Drill a 1-1/2" deep hole using a 3/8" drill bit.

Fig. A

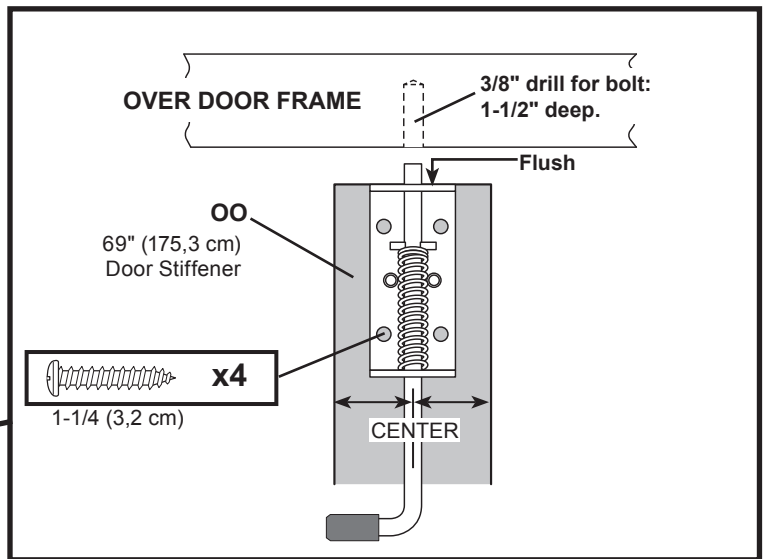
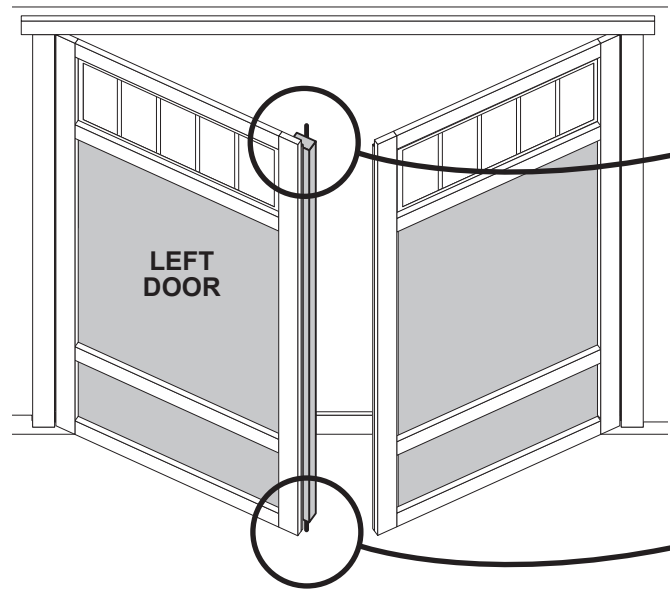
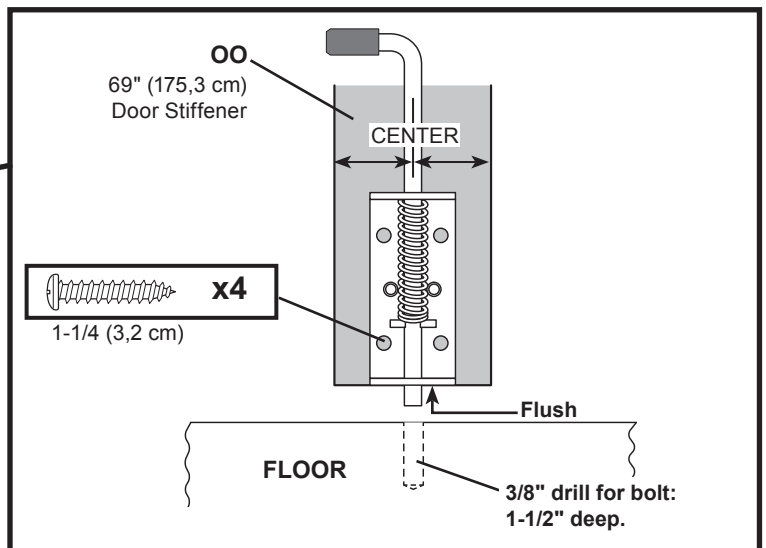



Fig. B



Your spring bolts are now installed.

CORNER TRIM

PARTS REQUIRED:

x4  3/8 x 1-3/4 x 82-1/2" (1 x 4,4 x 209,6 cm)

x4  3/8 x 1-3/4 x 81-7/8" (1 x 4,4 x 208 cm)



x64

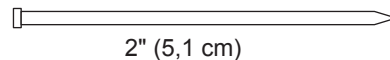

2" (5,1 cm)

✓ **BEGIN**

1 Install gable end **82-1/2"** corner trim flush to gable panel (**Fig. A**) and flush with eave wall panel (**Fig. B**). Secure with 2" finishing nails spaced evenly.

2 Install eave side **81-7/8"** corner trim flush to eave soffit and flush along seam of installed corner trim (**Fig. C**). Secure with 2" finishing nails spaced evenly.

Repeat steps to install trim to all four corners.

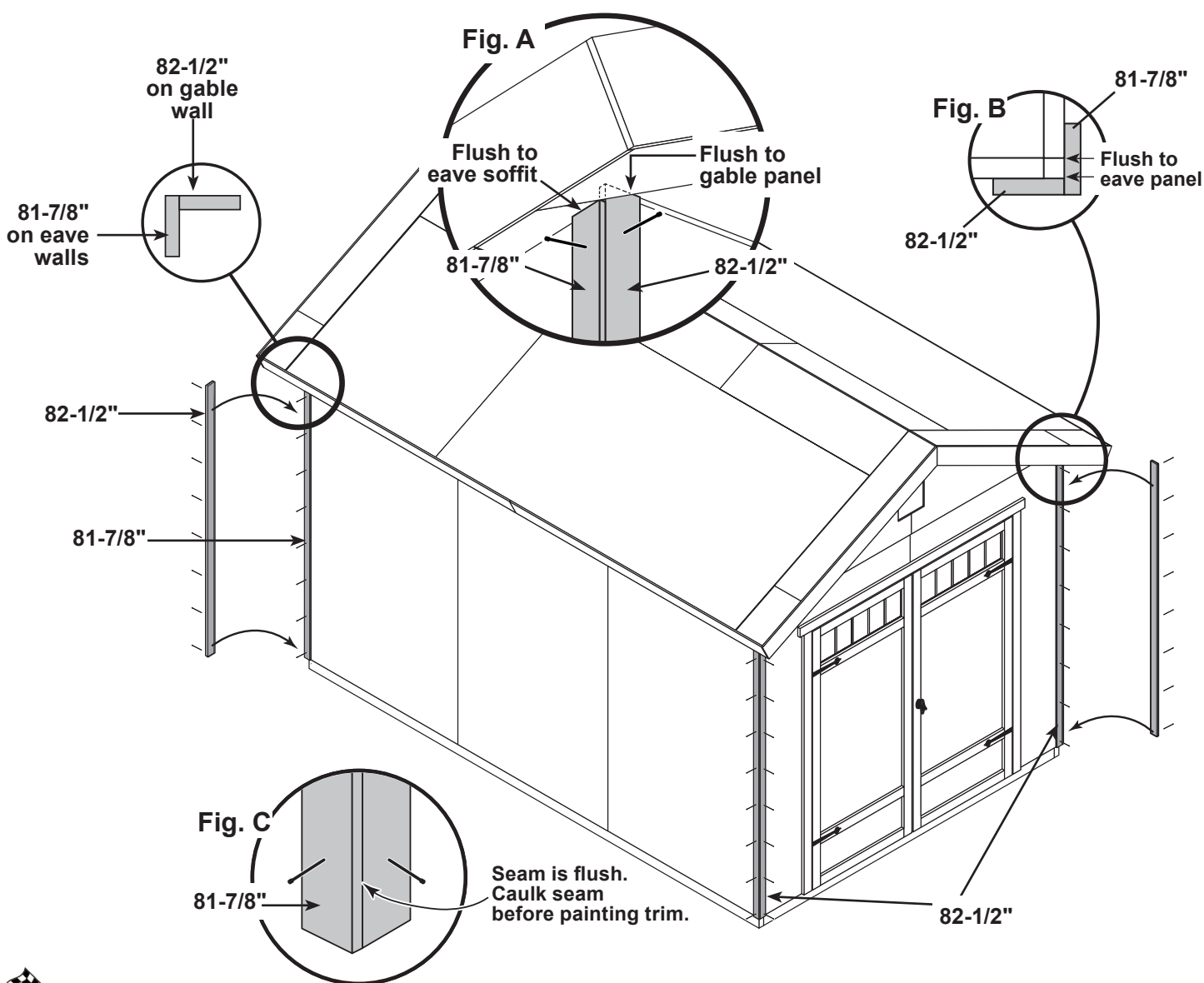

Your corner trim is now installed.

COLLAR TIE

PARTS REQUIRED:

x2 **GUA**
1 x 3 x 60" (2,5 x 7,6 x 152,4 cm)

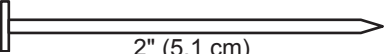

x12  2" (5,1 cm)



✓ **BEGIN**

1 Install collar ties on 2nd rafters from gable walls

Secure with 2" nails, as shown.



HINT: For best appearance install collar ties on rafters facing away from double door opening.

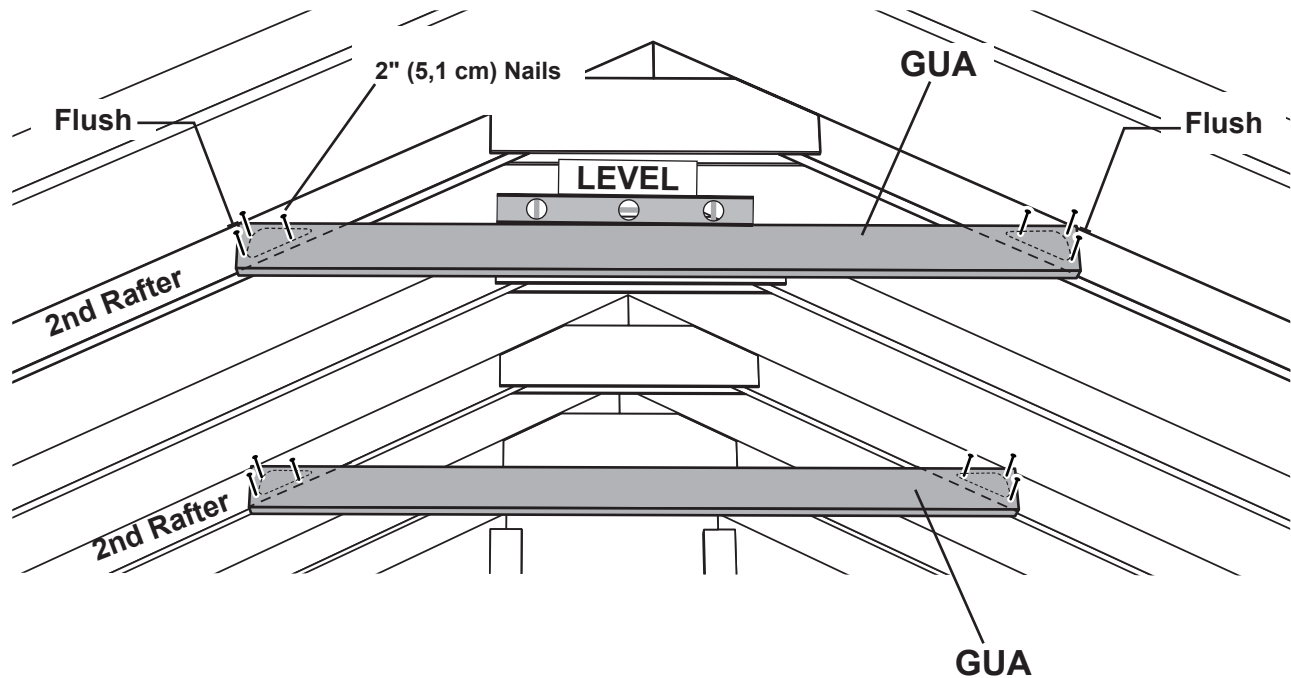



FINISH

Your collar ties are now installed.

GABLE VENTS

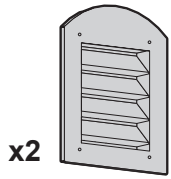
PARTS REQUIRED:



x8 
#8 x 1" (2,5 cm)
Pan Head Screws

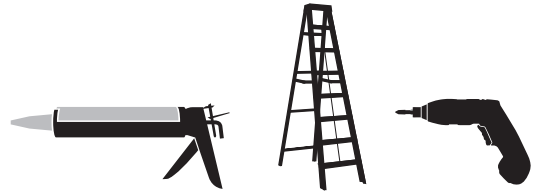

 **BEGIN**

1

Locate vent in the gable wall, as shown.

Seal vent from behind with exterior grade caulk before installing.

Secure vent with 1" screws.

Repeat to install 2nd vent in the opposite gable.

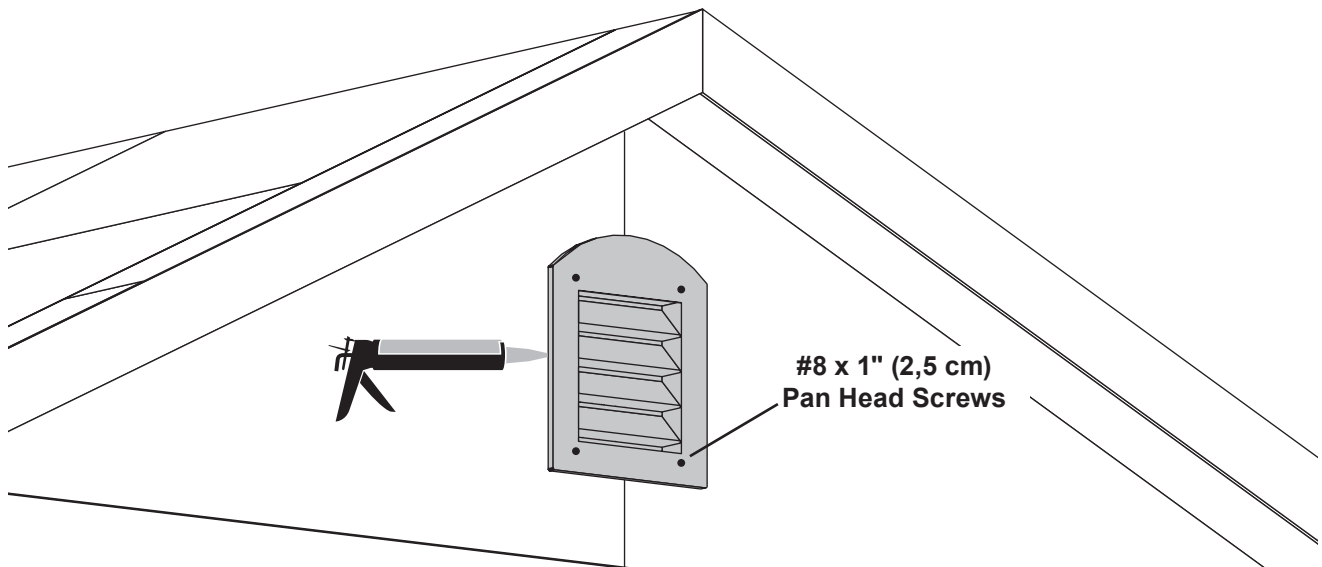

 **FINISH**

Your vents are now installed.

PAINT & CAULK

- NOT INCLUDED -



- Use acrylic latex caulk that is paintable. Caulk at all horizontal and vertical seams, between the trim and walls, and all around the door trim.
- Use a high quality exterior acrylic latex paint. When painting your building, there are a few key areas that can be easily overlooked that must be painted:
 - Bottom edge of all siding and trim
 - Inside of doors and all 4 edges

Note:

Prime all un-primed exterior wood before painting.
(Follow directions provided by manufacturer.)

ROOF FELT

- NOT INCLUDED -

- Install felt flush to all roof edges overlapping 3". Use minimal amount of roofing nails to hold in place.

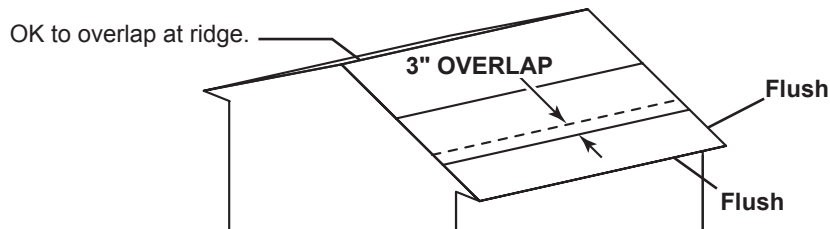

DRIP EDGE

- NOT INCLUDED -



- Install drip edge over roof felt on gable side and under roof felt on eave side (**Fig. A**).
- Do not use nails on side of drip edge that hangs over side of building.
- Only nail top of drip edge, as shown.

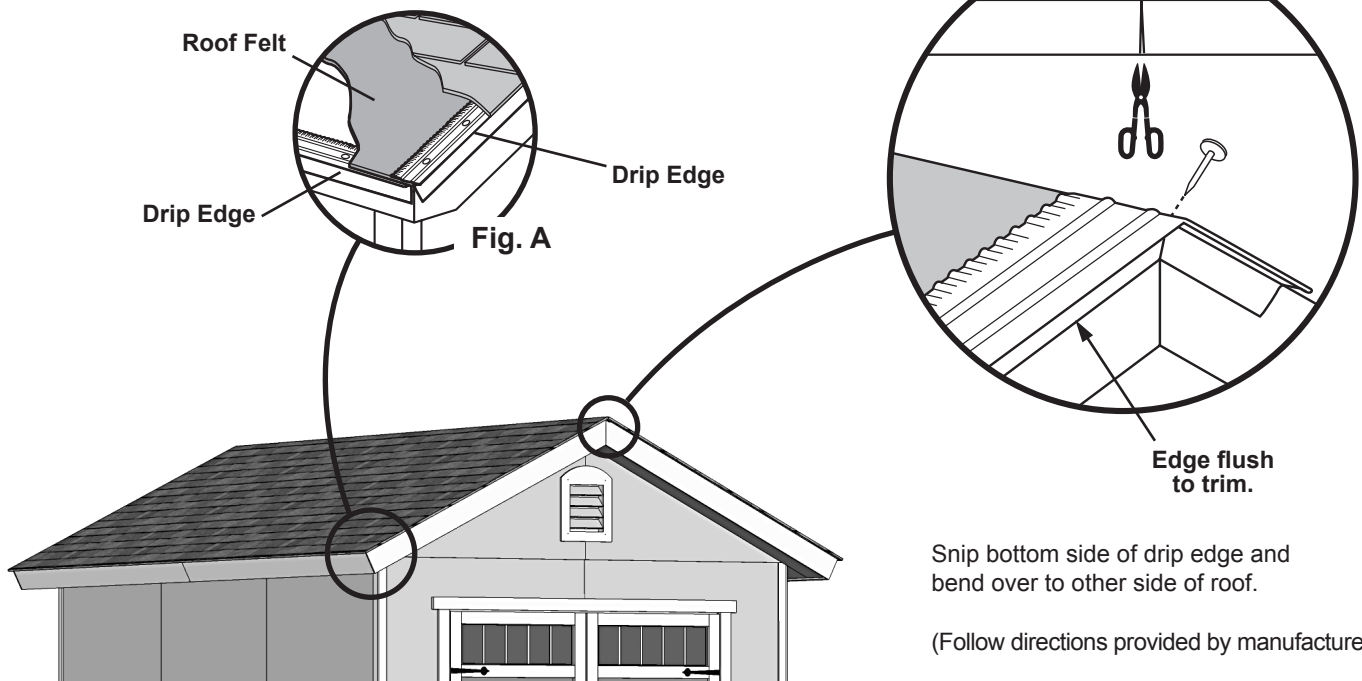

Snip bottom side of drip edge and bend over to other side of roof.

(Follow directions provided by manufacturer.)

SHINGLES

- NOT INCLUDED -

• Follow directions provided by manufacturer and these instructions.

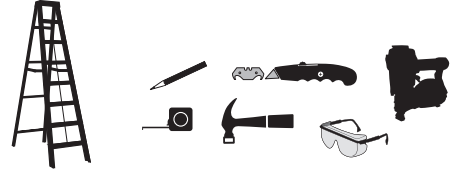

! Familiarize yourself with a 3-Tab Shingle.

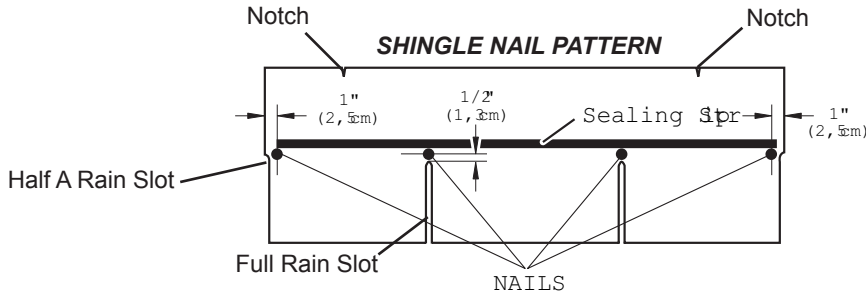

! NEVER DRIVE FASTENERS INTO OR ABOVE SEALING STRIPS.

✓ BEGIN

- 1** Install first starter row upside down and color up with a 1" overhang at back and bottom of roof panel. Use (4) nails per shingle. **Starter row must be straight and level all the way across with lower edge of roof deck.**
NOTE: If you have installed drip edge install shingles flush to drip edge.

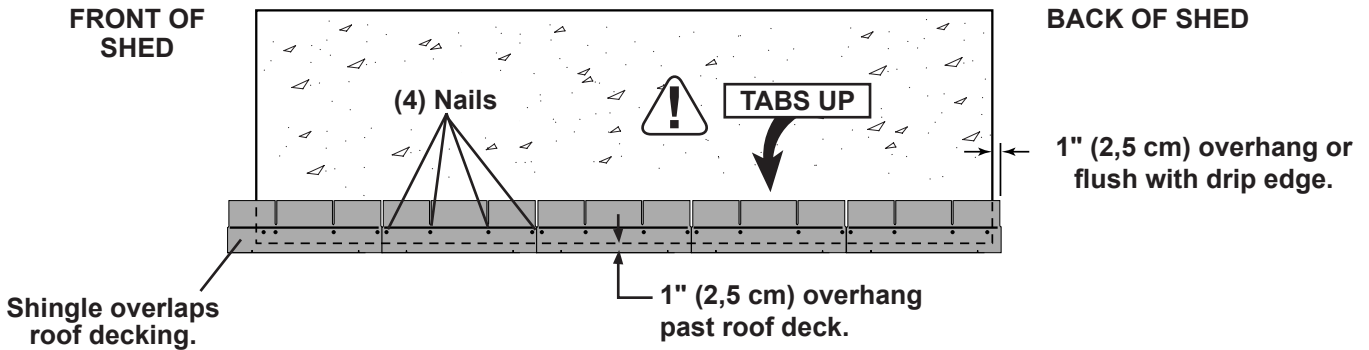

SHINGLES

continued...

- 2 Beginning at front of shed, install first row of shingles with notch at 1" past roof edge or flush with drip edge.

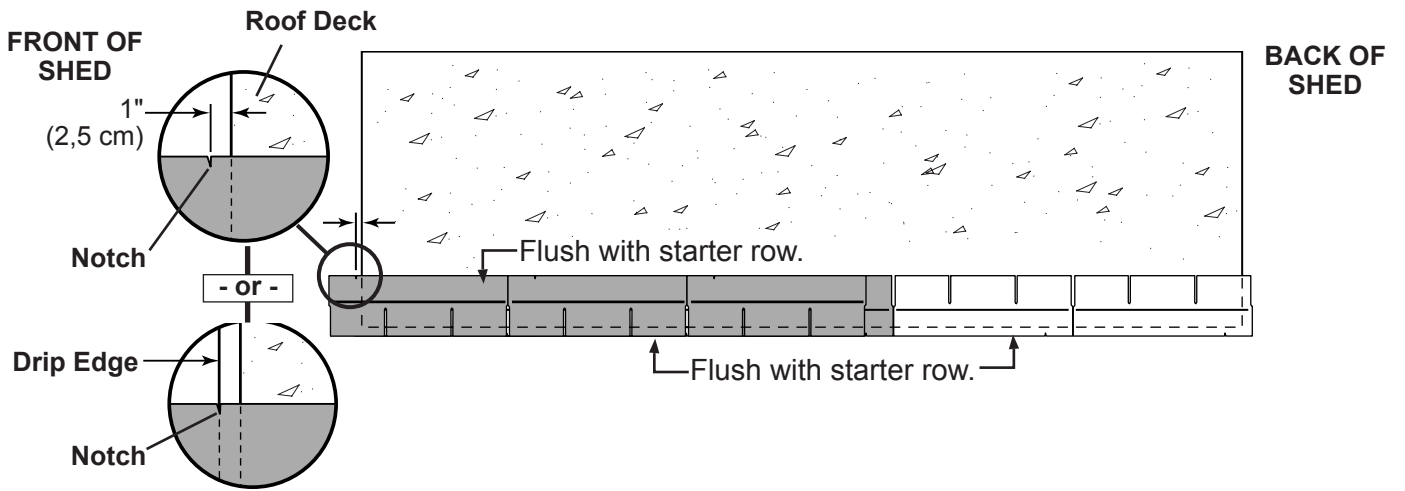

- 3 Install second row of shingles flush at top of first row's rain slots. Ensure 1" overhang or flush to drip edge at front, stagger each row.

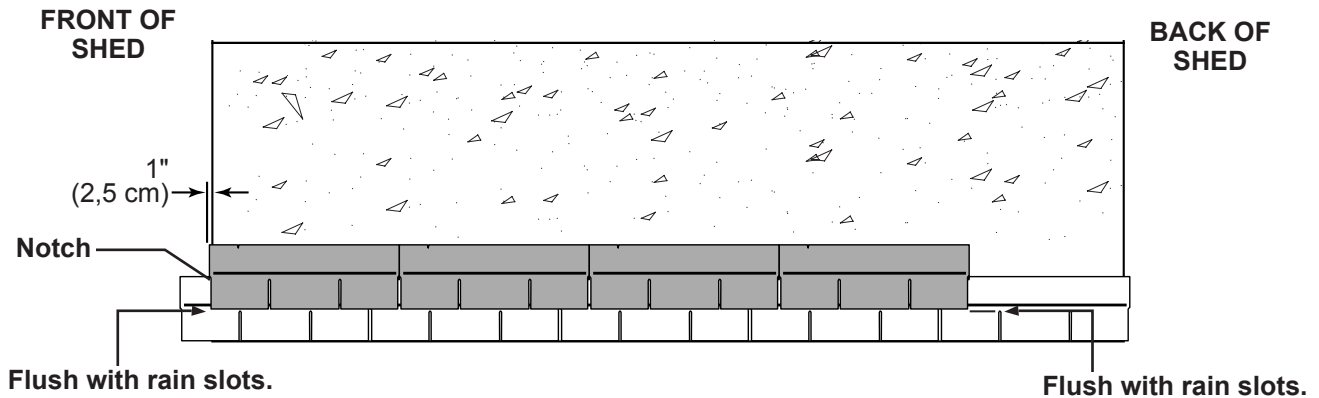

- 4 Continue installing rows of shingles by staggering at front.

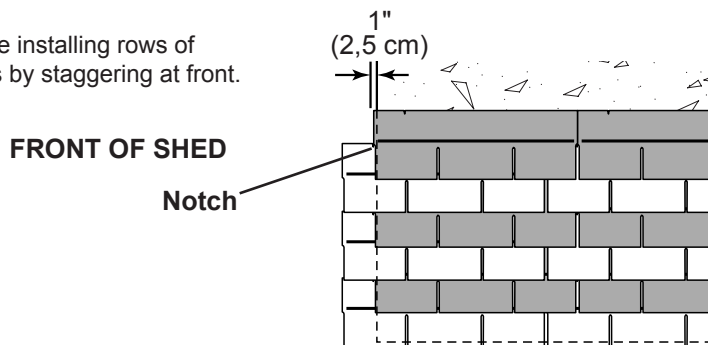

SHINGLES

continued...

- 5** Continue installing rows of shingles to the peak. At the peak make sure there is a maximum of 5" or less to the rain slot, as shown below. If shingles overlap at ridge cut to peak with a utility knife.

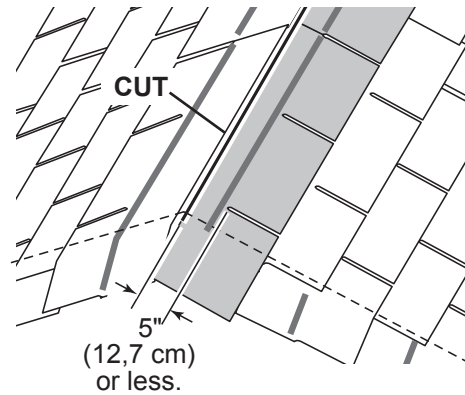
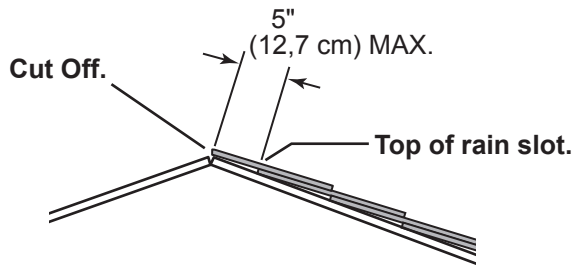

- !** • If more than 5" to rain slot you must install another row of shingles.

- 6** Repeat steps 1 - 5 to shingle the opposite side of your roof. Trim shingles at ridge.

- 7** Once both sides are shingled you need to trim ends. Strike a chalk line 1" from edge.

- 8** Using your shingle hooked blade carefully cut shingles along chalk line.

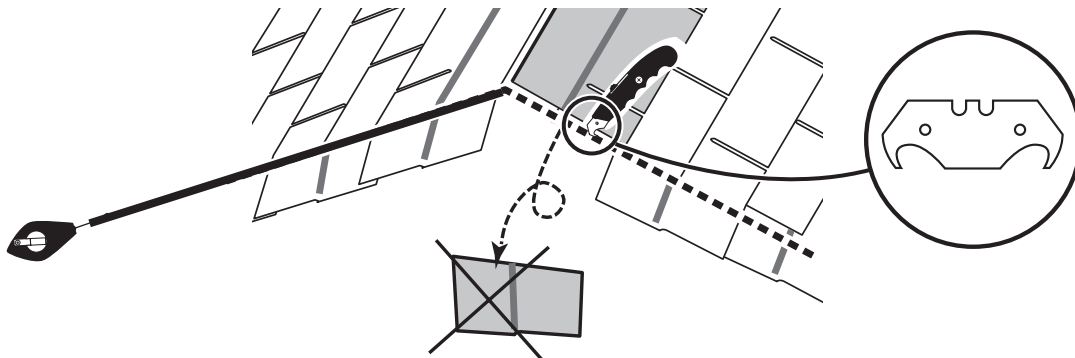

- 9** You have finished shingling your roof. Proceed to capping the ridge.

SHINGLES - RIDGE CAP

• You will finish off the top of the roof with a ridge cap made from shingles.

✓ **BEGIN**

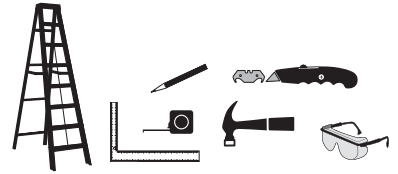

1 Cut shingles into THREE pieces. **Hint:** Use cut-off pieces first.

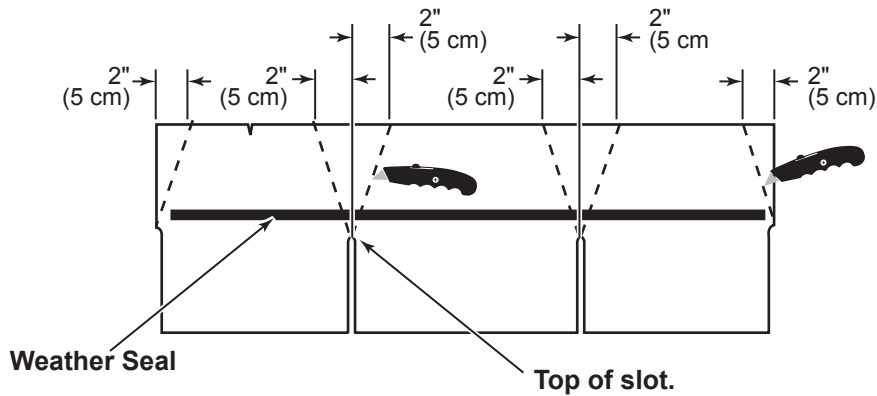

Score shingle, then snap-off angled cut.

Note: • You will need about 33 - 35 cut pieces.



2 Install first ridge cap flush to shingles at front, as shown.

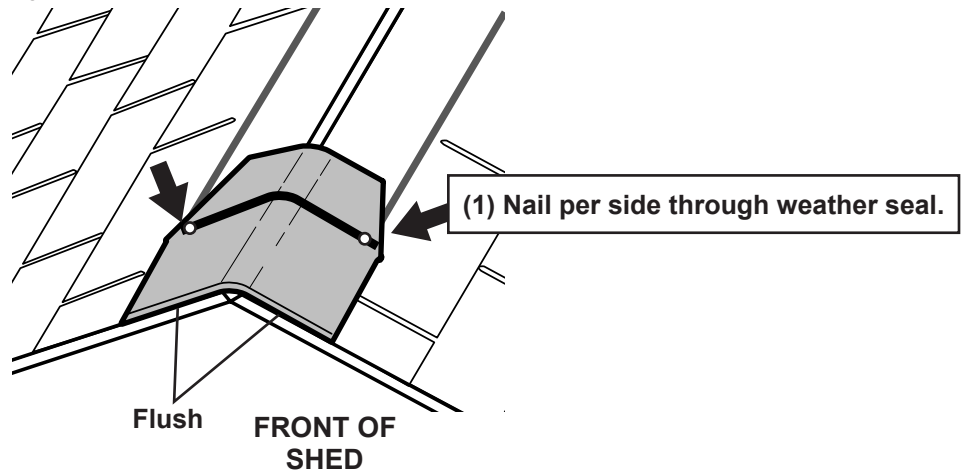

3 Install second ridge cap 5" back, as shown.

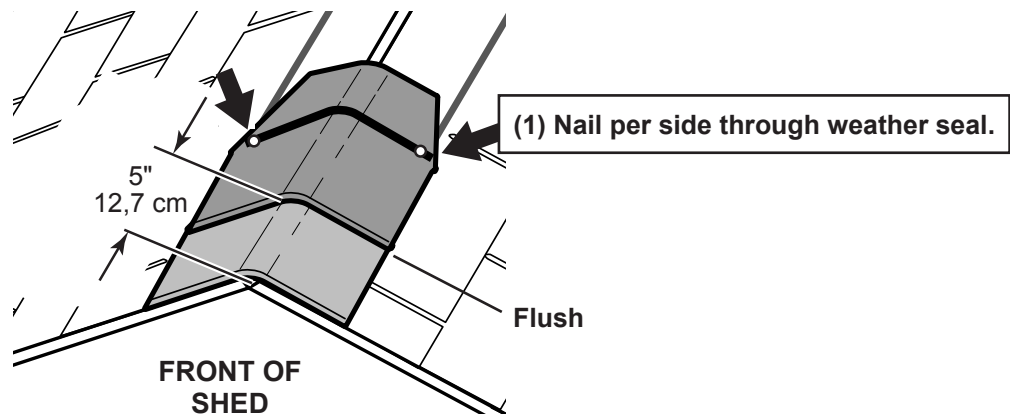

SHINGLES - RIDGE CAP

continued...

4 Continue installing ridge cap to back of roof.

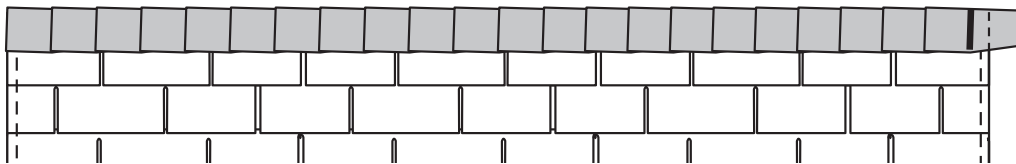

5 Make sure there is 4" between the shingle-color and edge of shingles.

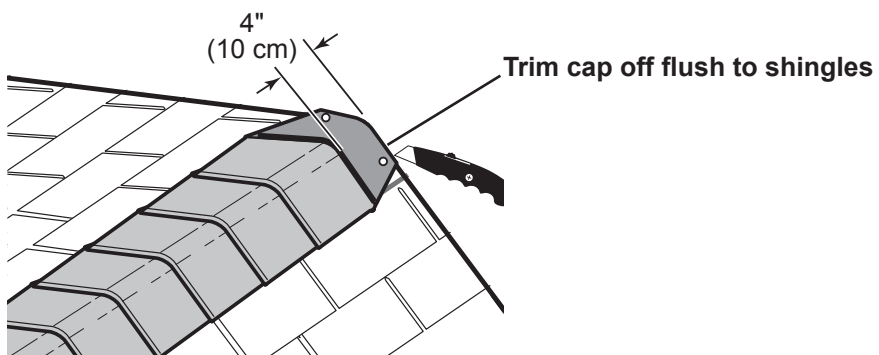

6 When you have 4" minimum of shingle color cut one piece to cap your roof.

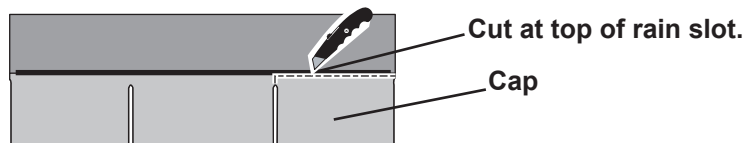

7 Install flush to shingles.

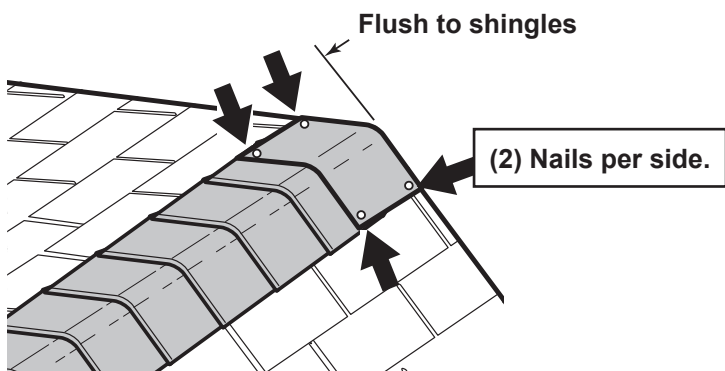

You have finished your ridge cap.

16134 8' x12' Order Form

CATEGORY	PART DESCRIPTION	PART SIZE	PART ITEM #	BUILDING QTY.	PART ID
2 X 3	Window Crippler	2 X 3 X 8" SOFFIT FILLER	Q 0800000000	1	RGF
2 X 4	Overhang Blocking & Gable Framing	2 X 4 X 4-7/8" OVERHANG BLOCK	O 0414000000	12	CLA
	Sidewall Top & Bottom Plate "A"	LUM SPF 2X4X92-5/8 #2&BTR	12305	4	TJ
	Sidewall Top & Bottom Plate "B"	2 X 4 X 44 3/8" PLATE	O 4406000000	4	HVC
	Rake Framing	2 X 4 X 61-7/8" 26.5" O/E RAKE	O 6114260500	8	CMA
	Rafters	2 X 4 X 61-7/8" 26.5" O/E RAF	O 6114260500N	14	CNA
	Wall Studs	2 X 4 X 78 1/2"	O 7808000000	20	AI
	Door Studs	2 X 4 X 68-1/2"	O 6808000000	2	YFA
	Gable Panel Filler	2 X 4 X 4" GABLE FILLER	O 0400000000	2	CQA
	Gable Panel Filler / Over Door Crippler	2 X 4 X 6 1/2" OVER DOOR	O 0608000000	5	UY
	Front/Back Wall Plates / Doubler "A"	LUM SPF 2X4X96 #2&BTR	12306	6	TP
	Sidewall Doubler "B"	2X4X48" DOUBLER/ PLATE/ CRATE	O 4800000000	2	SP
	Endwall Doubler	*2 X 4 X 89" PLATE	O 8900000000	2	SZ
Door Header	2 X 4 X 67"	O 6700000000	2	AM	
1 X 3 PINE	Gauge Block	1 X 3 X 5" PINE FILLER	U 0500000000	1	GAA
	Collar Tie	LUM SPF 1X3 X60" PART & PRE-	U 6000000000P	2	GUA
7/16 OSB	Roof Panel "A"	OSB 7/16" x 4' x 8'	11110	2	---
	Roof Panel "B"	7/16" OSB 13-7/8" X 96" ROOF	C 96001314000	2	---
	Roof Panel "C"	7/16" OSB 47 7/8" X 48" ROOF	C 48004714000	2	---
	Roof Panel "D"	7/16" OSB 13-7/8" X 48" ROOF PANEL	C 48001314000	2	---
	Gable Roof Panel "A"	7/16" X 8-1/2" X 48" ROOF PANEL	C 48000808000	4	---
	Gable Roof Panel "B"	7/16" OSB 8-1/2" X 13-7/8" ROOF PANEL	C 13140808000	4	---
	Door Header Filler	7/16" OSB 3 1/4" X 66 3/4" HEADER	C 66120304000	1	---
GUSSETS	Gusset	EZ 8" 6" X 24" GUSSET 28"-	J 24000600280	12	---
NO GROOVE SIDING	Wall panel at Door -RIGHT	3/8"NG RT PANEL@DOOR (33445,	K 84004800510	1	---
	Wall panel at Door -LEFT	3/8"NG LT PANEL@DOOR (33445,	K 84004800520	1	---
	Backwall & Sidewall Panel	SIDING NGSE 3/8X4'X7'	11507	8	---
	Gable Panels w/ Hole -RIGHT	3/8"NGX28"X48"RT GABLE HOLE	K 48002800100	2	---
	Gable Panels w/ Hole -LEFT	3/8"NGX28"X48"LT GABLE HOLE	K 48002800200	2	---
	Gable Soffit	3/8" NGx7-7/8" x 59 15/16"	K 59150714000	4	---
	Eave Soffit	3/8" NGx5-7/8" X 73"	K 73000514000	4	---
	Eave Fascia	3/8" NGx4-3/4" X 80-7/8"	K 80140412000	4	---
	Gable Trim-RIGHT	3/8"NGx4-3/4" x 62-7/16"-26.5	K 62070412100	2	---
	Gable Trim-LEFT	3/8"NGx4-3/4" x 62-7/16"-26.5	K 62070412200	2	---
	Corner Trim Eave Side	3/8"NGx1-3/4"x 81-7/8" TRIM	K 81140112000	4	---
	Corner Trim Gable Side	3/8"NGx1-3/4"x 82-1/2" TRIM	K 82080112000	4	---
19/32 X 3 SMART TRIM	Horizontal Door Rails	19/32 TST 2 1/2" X 26 5/8"	UT26100208000	4	AH
	Door Trim Hinge/Over Door	19/32 TST 2 1/2" X 72" TRIM	UT72000208000	1	ZJ
PURCHASED COMPONENTS	Door Stiffener	LSL 1-1/4 X 2-1/4 X 69 PET	12715	2	OO
	Vents- Exterior White	VENT 8X10, APL# CV12X18W-PE, A	15021	2	---
	Threshold	THRESHOLD 7/8" X 1-1/2" X 63-7/8	15420	1	---
	Black "T" & "D" Handle w/ Faux Hinges	HANDLE - T & "D" HANDLES, FAUX	15220	1	---
	Transoms For Doors	WINDOW 9 X 27 TRANSOM (SINGLE)	15235	2	---
	Hardware Kit	H/K (33382) SOMERFIELD 8X12 GABLE	15407	1	---
	Spring Bolt	SPRING BOLT, 1.63 TRAVEL, W/SCREWS	15129	2	---
PACKAGING	Instructions		16134	1	---
Right Door Assembly	33095-R				
	Door Panel	3/8" NGx31-3/8" x 71-1/2"	K 7108310600R	1	---
	Right Hinge Assembly	HINGE RIGHT (RED) 19/32x3 THIN TRIM	30121-TT	1	---
	Vertical Door Stiles	19/32 TST 2 1/2" X 71 5/8"	UT71100208000	2	GY
Horizontal Door Rails	19/32 TST 2 1/2" X 26 5/8"	UT26100208000	2	AH	
Left Door Assembly	33095-L				
	Door Panel	3/8" NGx31-3/8" x 71-1/2"	K 7108310600R	1	---
	Left Hinge Assembly	HINGE LEFT (GREEN) 19/32x3 THIN TRIM	30131-TT	1	---
	Vertical Door Stiles	19/32 TST 2 1/2" X 71 5/8"	UT71100208000	2	GY
Horizontal Door Rails	19/32 TST 2 1/2" X 26 5/8"	UT26100208000	2	AH	

LIMITED CONDITIONAL WARRANTY*

Backyard Storage Solutions, LLC warrants the following:

1. Every product is warranted from defects in workmanship and manufacturing for 1 year.
2. All accessories, hardware and metal components are warranted for 2 years.
3. All Oriented Strand Board (OSB) is warranted for 2 years
4. Siding and Trim is warranted for 10 years.
5. Solar Shed windows are warranted for 1 year.
6. Cedar lumber is warranted for 15 years.
7. Preserved Pine is warranted for 10 years.
8. Redwood is warranted for 10 years.

Backyard Storage Solutions, LLC will repair, replace or pay for the affected part. In no event shall Backyard Storage Solutions, LLC pay the cost of labor or installation or any other costs related thereto. All warranties are from date of purchase. If a cash refund is paid on an affected part, it will be prorated from the date of purchase.

CONDITIONS

The warranty is effective only when:

1. The unit has been erected in accordance with the assembly instructions.
2. The unit has been properly shingled and painted or stained and reasonably and regularly maintained thereafter.
3. The failure occurs when the unit is owned by the original purchaser.
4. Backyard Storage Solutions, LLC has received the warranty registration card within thirty (30) days of purchase and notification of the failure in writing within the warranty period specified above.
5. Backyard Storage Solutions, LLC has had reasonable opportunity during the sixty (60) days following receipt of notification to inspect and verify the failure prior to commencement of any repair work.

REQUIREMENTS

Storage Buildings

To validate your warranty, it is necessary to properly maintain your Backyard Storage Solutions, LLC unit; shingle the roof and paint or solid-colored stain the siding using quality, 100% acrylic latex exterior product with a minimum of two (2) coats within thirty (30) days of assembly; caulk above all doors and all horizontal and vertical trim boards; paint and seal all exposed edges, sides and faces of siding/trim and OSB siding to include all exterior walls and all sides and all edges of doors.

Gazebos & Pergolas

To validate your warranty, it is necessary to properly maintain your Backyard Storage Solutions, LLC unit. This includes treating all of the exposed cedar and pine surfaces on your gazebo or pergola structure with an exterior grade wood preservative, an exterior oil-based semi-transparent stain, an acrylic latex exterior paint or an acrylic latex solid color exterior stain within 30 days of assembly and as needed thereafter to maintain your warranty.

Keep vegetation trimmed away from building and make sure siding panels and trim do not come in contact with masonry or cement. The minimum ground clearance for siding must be one half inch (½ inch) from concrete slab or two and one half inches (2 ½") from the ground when building is erected or constructed on a treated wood floor kit. Water from sprinklers must be kept off unit. In no event will Backyard Storage Solutions, LLC be responsible for any indirect, incidental, consequential or special damages nor for failure(s) that are caused by events, acts or omissions beyond our control including, but not limited to, misuse or improper assembly, improper maintenance (which eventually leads to rot or decay) and acts of God. Backyard Storage Solutions, LLC will not be held responsible for any labor costs incurred to construct your unit.

This warranty gives you certain specific rights that vary from state to state.

CLAIM PROCEDURE

To make a claim under this warranty, you can either call 1-888-827-9056 or email: customerservice@backyardproducts.com.

Please have ready the information below when you call or include the information in your email:

1. The model and size of the product.
2. A list of the part(s) for which the claim is made.
3. Proof of purchase of the Backyard Storage Solutions, LLC item, as shown on the original invoice or receipt.
4. Run code: found on exterior product label or assembly instructions enclosed in the product package.

All other inquiries can be mailed to:

Backyard Storage Solutions, LLC
Attn: Customer Service
1000 Ternes
Monroe, MI 48162

***WARRANTY TERMS MAY VARY OUTSIDE THE U.S.A.
IMPORTANT: This is your warranty certificate.**

10Y MV LDR: 3/20/2019