

# Assembly Instructions

## Instructions d'assemblage



### We're here to help - Do not return this product !

Call, email or find us online first !

- If you need help with assembly
- If you received a damaged or defective part
- If you are missing hardware

We will process replacement parts in 3-5 business days or less.

### *Nous sommes là pour vous - Ne retournez pas ce produit !*

*Appelez, écrivez ou trouvez-nous en ligne d'abord !*

- *Si vous avez besoin d'aide avec l'assemblage*
- *Si vous avez une pièce manquante ou endommagée*
- *S'il vous manque de la quincaillerie*

*Nous vous enverrons les pièces de rechange dans un délai de 3 à 5 jours ouvrables, ou moins.*

Lot #

**Weight capacity : 175 lb**

*Capacité maximale : 175 lb*

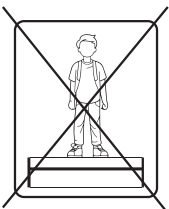
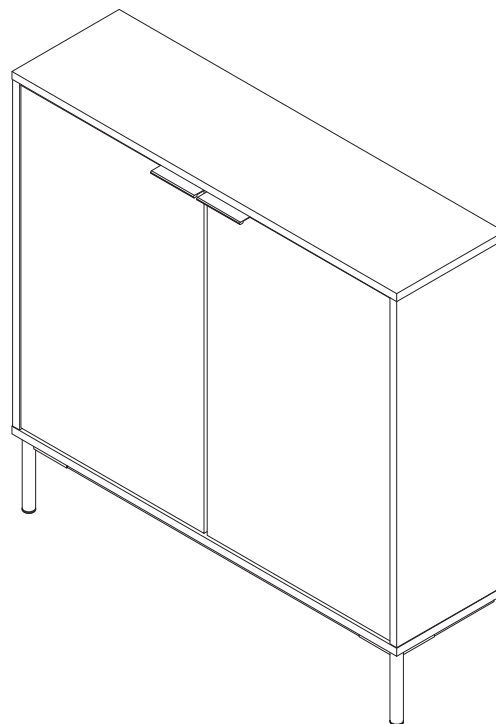

**Read these assembly instructions carefully before beginning. Verify that you have in hands all the wood parts and hardware. Keep this document for future reference.**

*Lisez attentivement ce guide d'assemblage avant de débiter. Assurez vous que toutes les composantes de bois et de quincaillerie sont présentes. Conservez ce document.*



**Two people are required to assemble and move this unit.**

*Deux personnes sont requises pour assembler et déplacer ce meuble.*



**Safety First ! Do not allow children to climb on or play with furniture.**

*Attention ! Ne permettez pas aux enfants de jouer ou grimper sur les meubles.*



**Never leave liquids or damp clothes on your furniture.**

*Ne jamais laisser de liquide ou de linge humide sur votre meuble.*



**Never use chemical product to clean your furniture.**

*Ne jamais utiliser de produits chimiques pour nettoyer votre meuble.*



**Do not place your furniture in direct sunlight.**

*N'exposez pas votre meuble à la lumière directe du soleil.*



**To clean your furniture, dampen a soft cloth with a mild solution of dishwashing liquid. Squeeze excess water. Clean unit and wipe it dry.**

*Pour nettoyer votre meubles, trempez un chiffon doux dans une faible solution de liquide pour la vaisselle et d'eau. Bien essorer. Nettoyez le meuble et essuyez soigneusement le surplus d'eau avec un linge sec.*

**Use**  
*Utiliser*

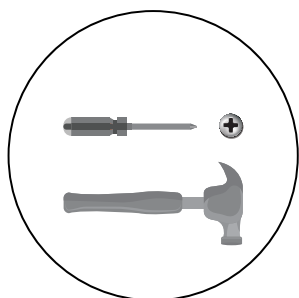

**stud sensor**  
détecteur  
de montants

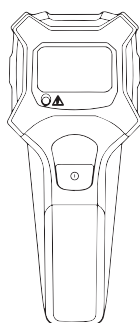

**Don't Use**  
*Ne pas utiliser*

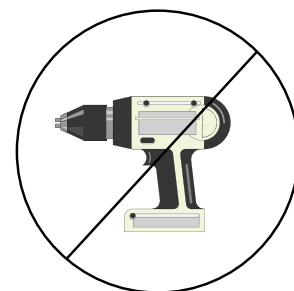

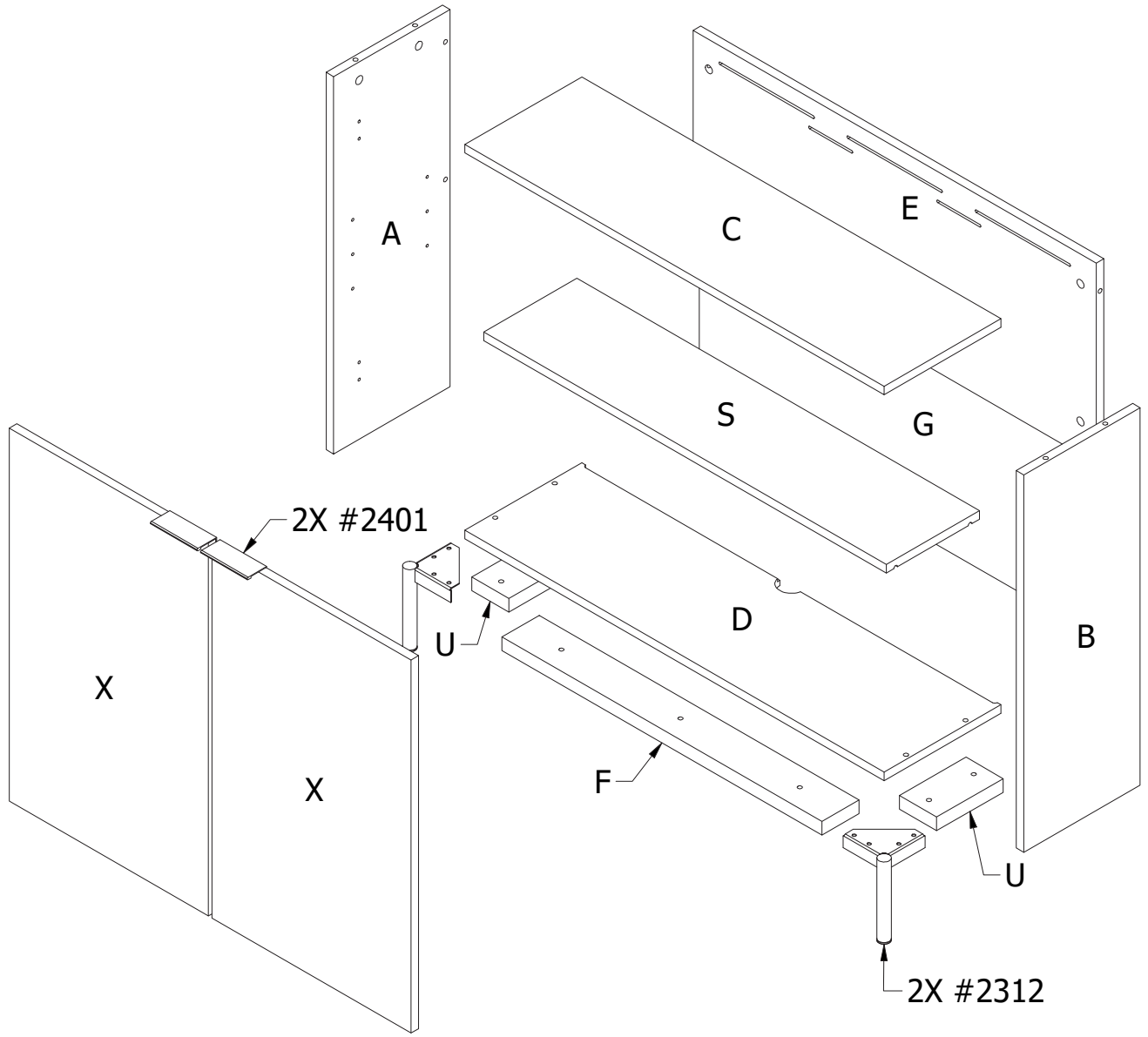

# Exploded View

*Vue éclatée*

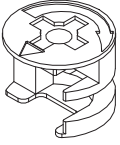
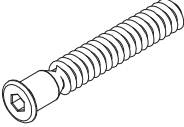
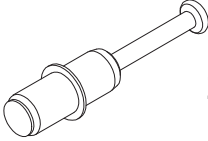
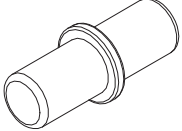
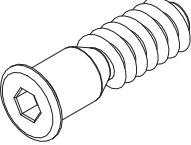
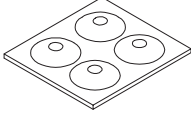
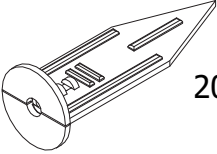
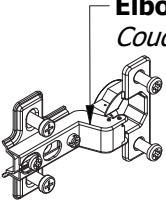
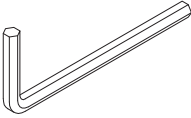
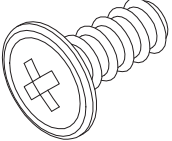
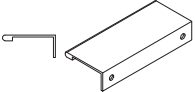

## Hardware List / Liste de quincaillerie

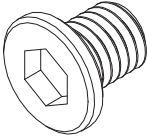
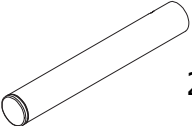
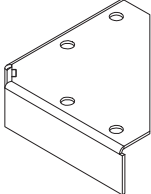
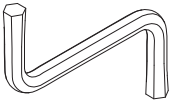
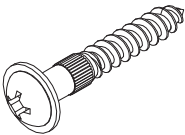
 <p style="text-align: center;">8X 20-0203</p>	 <p style="text-align: center;">4X 20-0111</p>	 <p style="text-align: center;">8X 20-2200</p>
 <p style="text-align: center;">6X 20-1110</p>	 <p style="text-align: center;">7X 20-0123</p>	 <p style="text-align: center;">2X 20-0527</p>
 <p style="text-align: center;">2X 20-2207</p>	<p style="text-align: center;"><b>Elbow here</b> <i>Coudé ici</i></p>  <p style="text-align: center;">4X 20-0405</p>	 <p style="text-align: center;">1X 20-0219L</p>
 <p style="text-align: center;">8X 20-2215</p>	  <p style="text-align: center;">2X 20-2401</p>	 <p style="text-align: center;">2X 20-2403</p>
 <p style="text-align: center;">2X 20-2312A</p>	 <p style="text-align: center;">2X 20-2312B</p>	 <p style="text-align: center;">1X 20-2300</p>
 <p style="text-align: center;">2X 20-2402</p>		

# STEP/Étape : 1

**Install the 8 cam locks # 0203 into the panels A, B and E**  
**Install the 8 push bolts # 2200 on the panels A, B and C**

*Installez les 8 excentriques # 0203 dans les panneaux A, B et E*  
*Installez les 8 boulons # 2200 sur les panneaux A, B et C*

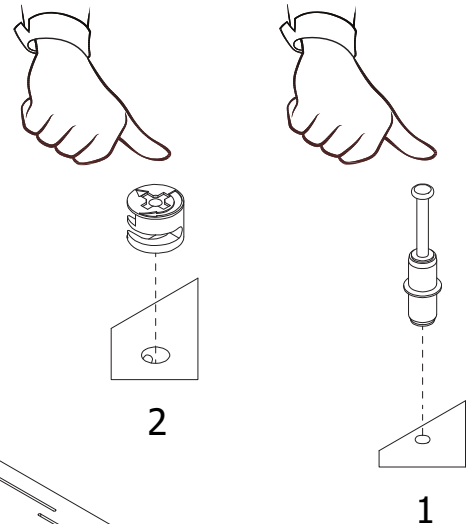
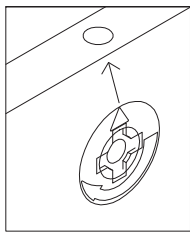

**Press firmly into the hole**  
*Pressez fermement dans la cavité*

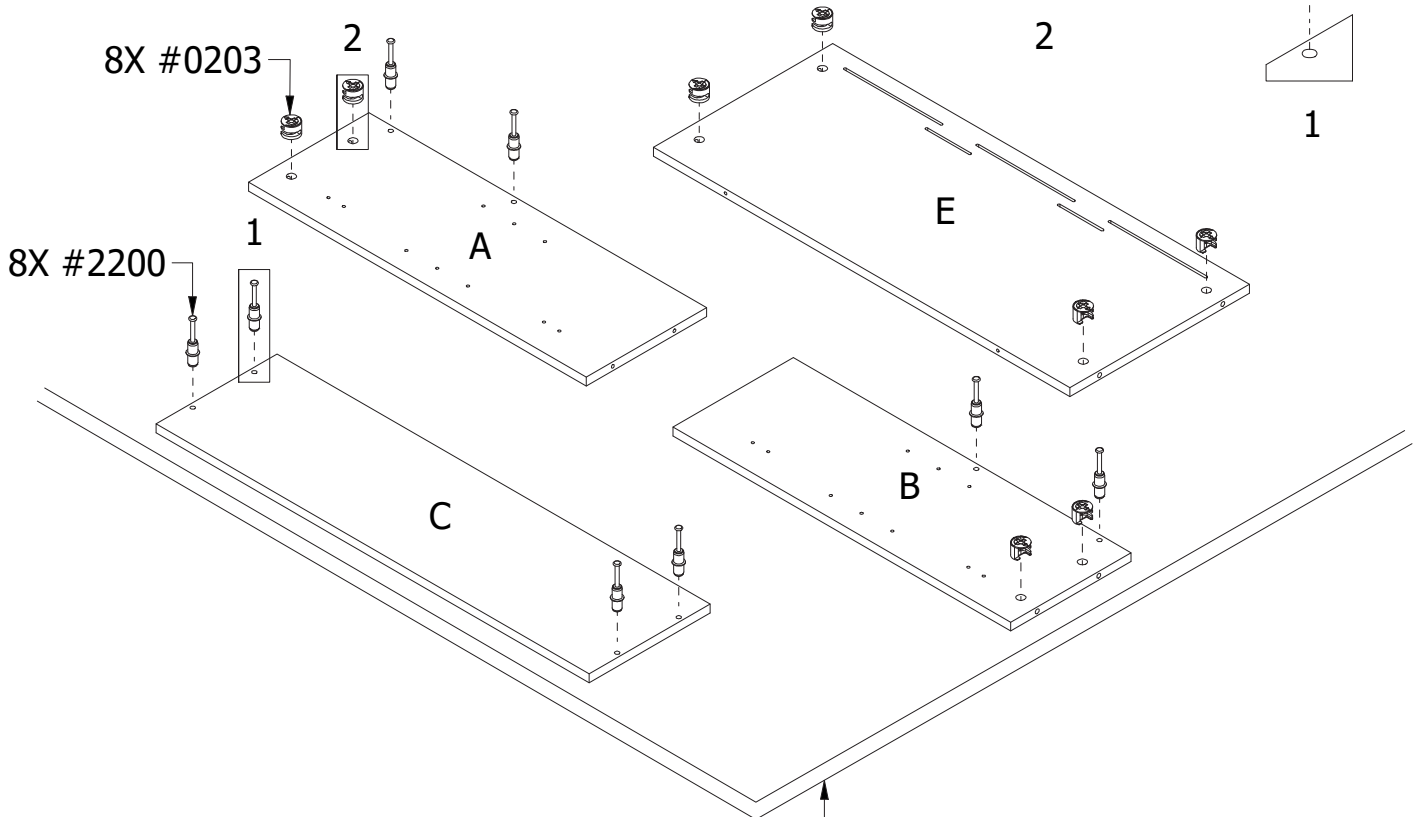

**Add a protection under the parts on all assembly steps**  
*Ajoutez une protection sous les pièces à chaque étape*

## STEP/Étape : 2

**Fasten the panel E to the panel A and B. Then, tighten the 4 cam locks # 0203 located on panel E**

*Assemblez les panneau E avec les panneau A et B. Serrez ensuite les 4 excentriques # 0203 se trouvant sur panneau E*

### IMPORTANT/IMPORTANTE

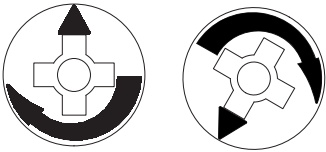

Turn clockwise 2/3 of a turn  
and firmly tighten

*Tournez vers la droite 2/3 de tour  
et serrez fermement*

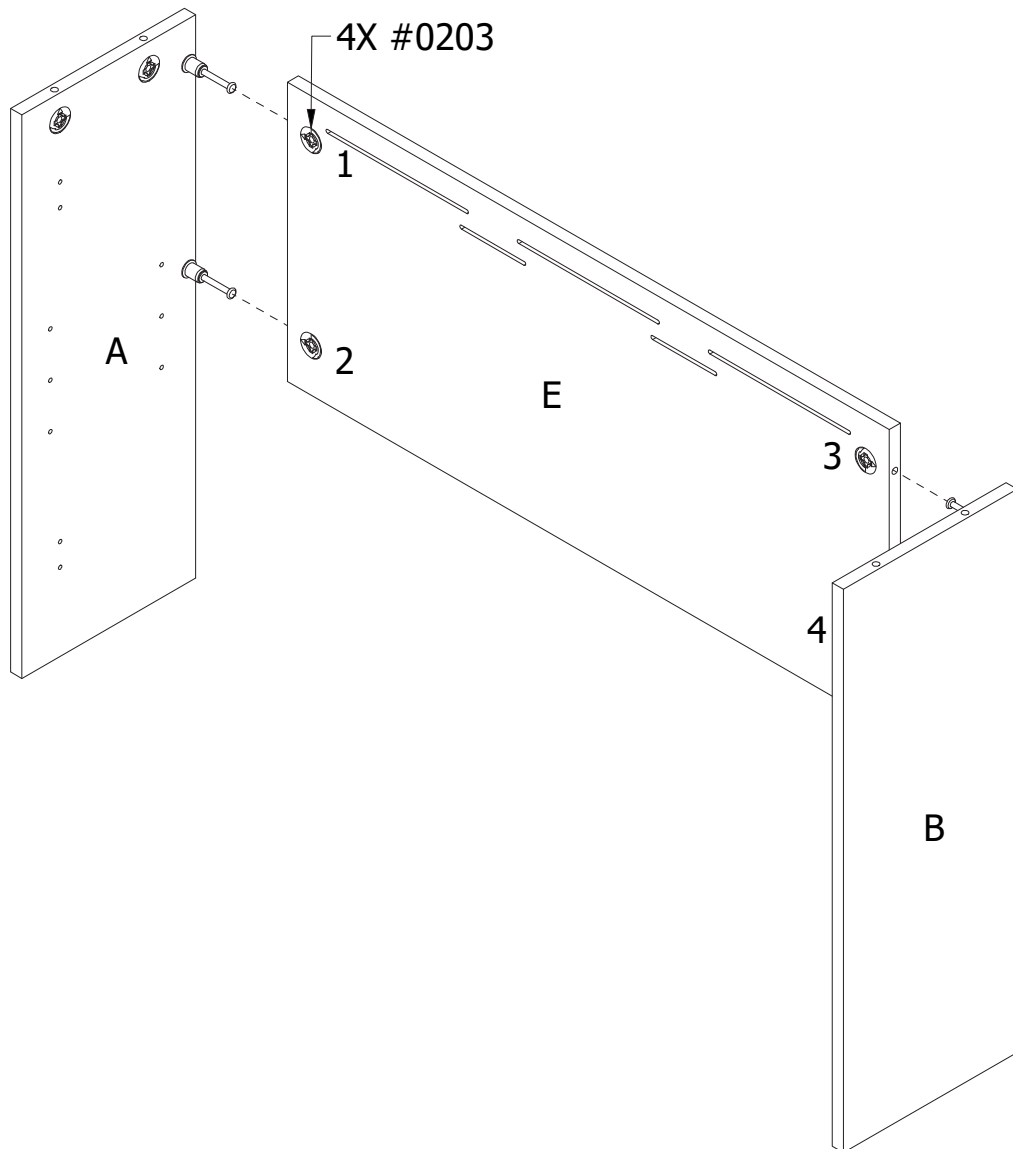
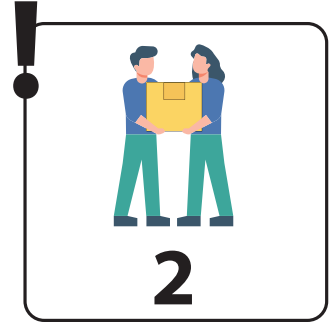

## **STEP/Étape : 3**

**Fasten the panel C to the A-E-B . Then, tighten the 4 cam locks # 0203 located on panel A and B**

*Assemblez les panneau C avec les panneau A-E-B. Serrez ensuite les 4 excentriques # 0203 se trouvant sur panneau A et B*

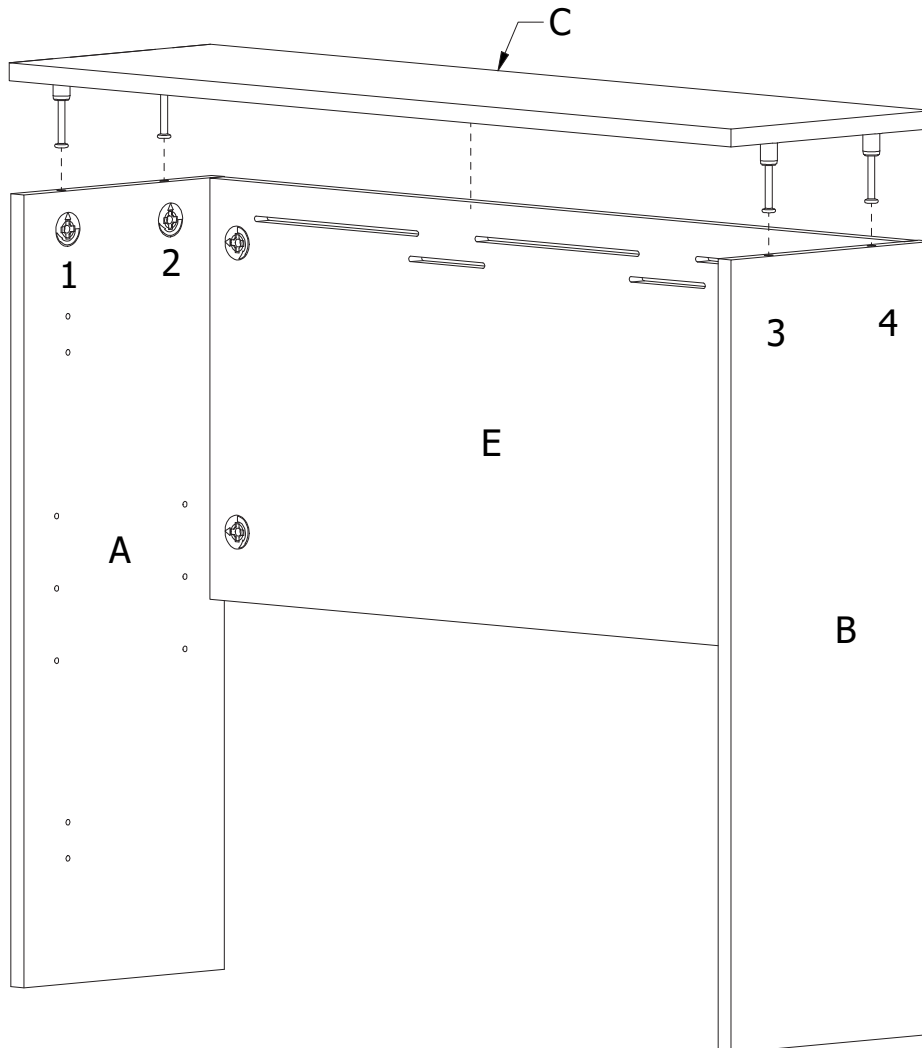

### **IMPORTANT/ IMPORTANTE**

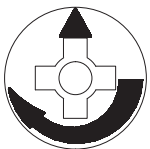

Turn clockwise 2/3 of a turn  
and firmly tighten

*Tournez vers la droite 2/3 de tour  
et serrez fermement*

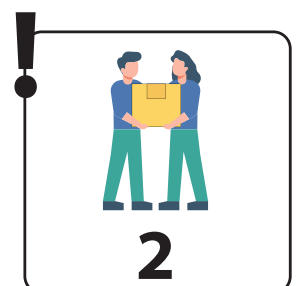

## STEP/Étape : 4

Use the Allen key # 2300 and 4 screws # 0111 to fasten the panel D to the panel A-B

Utilisez la clé Allen # 2300 et 4 vis #0111 pour fixer le panneau D au panneau A-B



**Flip the Assembly upside down**  
*Retournez l'assemblage à l'envers*

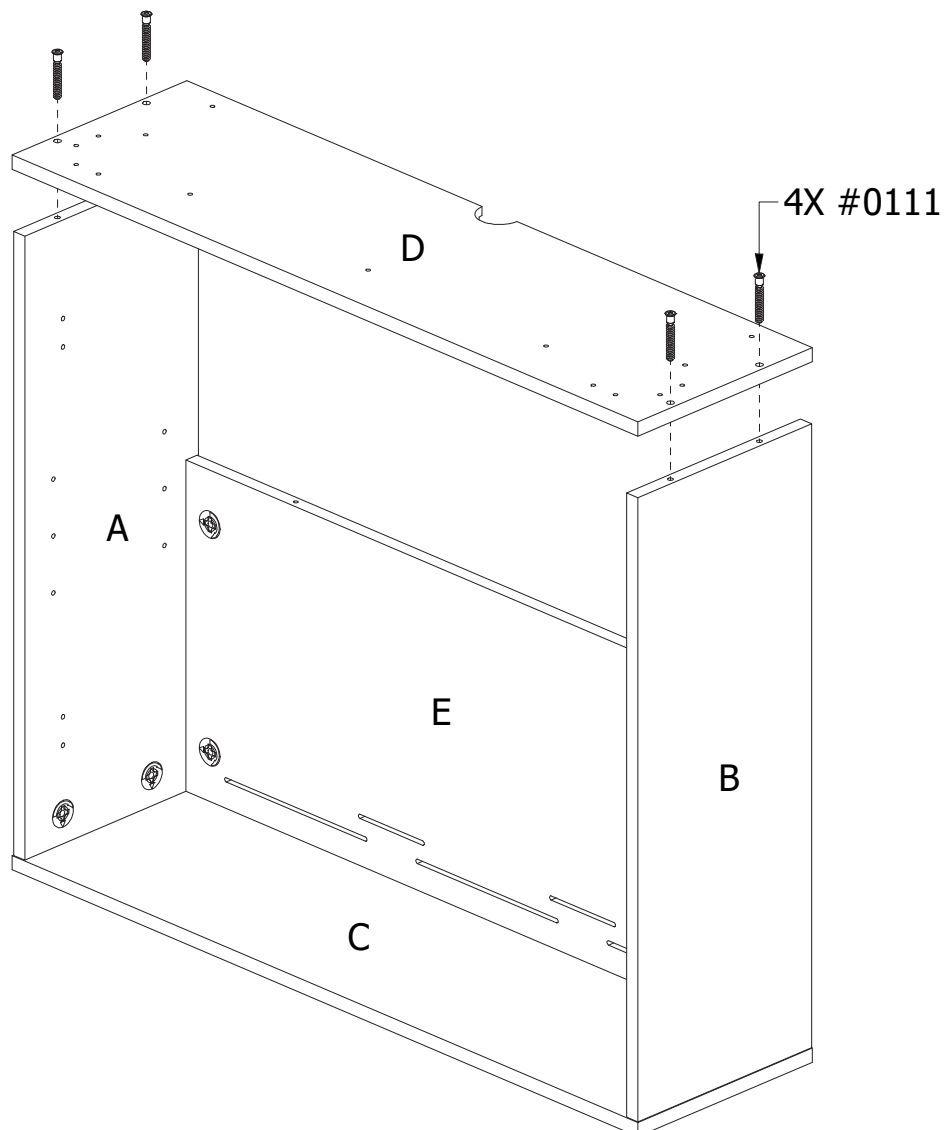
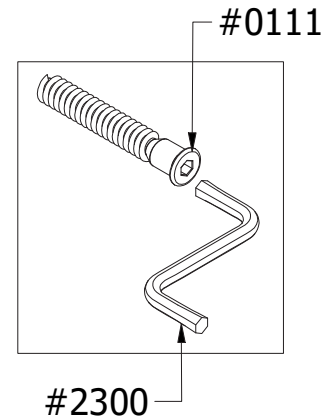

## STEP/Étape : 5

Use the Allen key # 2300 and 7 screws # 0123 to fasten the panel U and F to the panel D

Utilisez la clé Allen # 2300 et 7 vis #0123 pour fixer le panneau U et F au panneau D

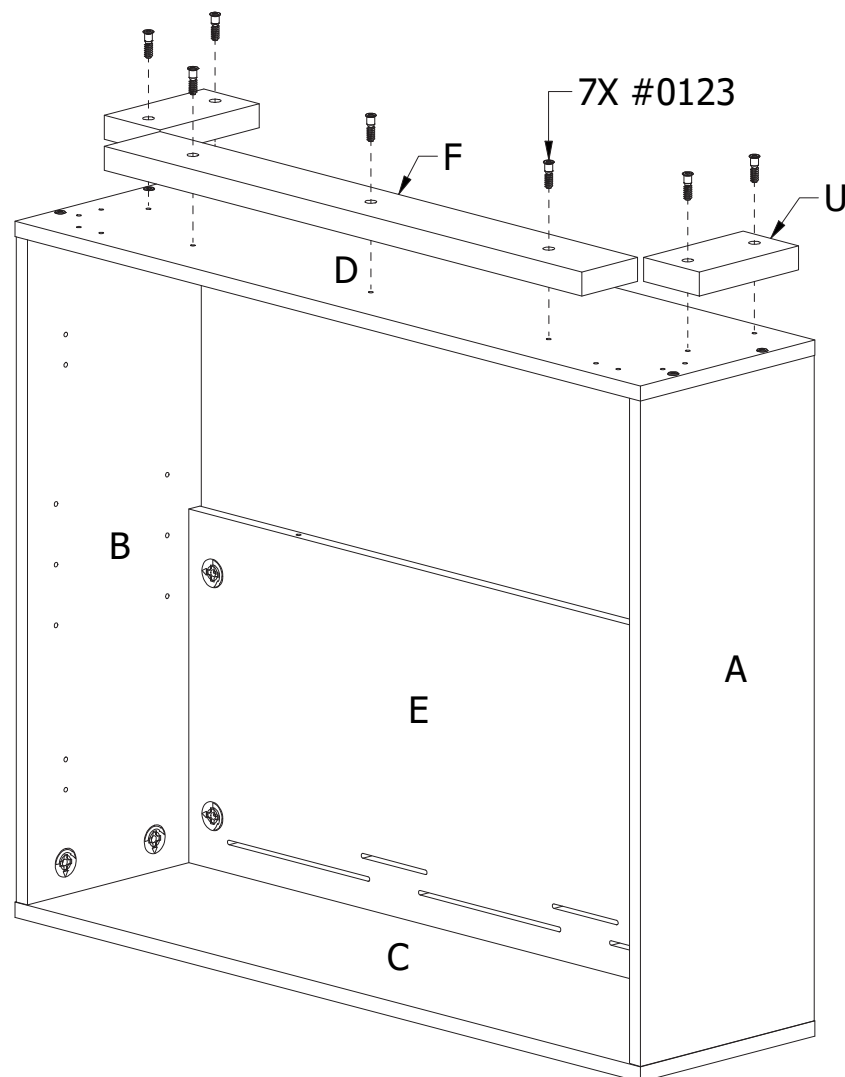
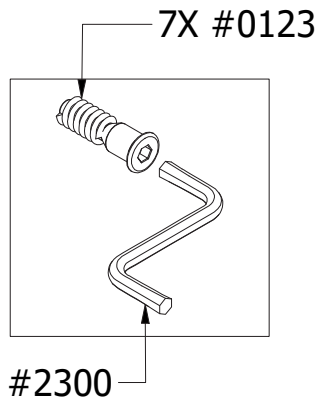

## STEP/Étape : 6 (x2)

Use the Allen key # 0219L and 1 screw # 2403 to fasten # 2312B to the # 2312A

Utilisez la clé Allen # 0219L et 1 vis # 2403 pour fixer le # 2312B au # 2312A

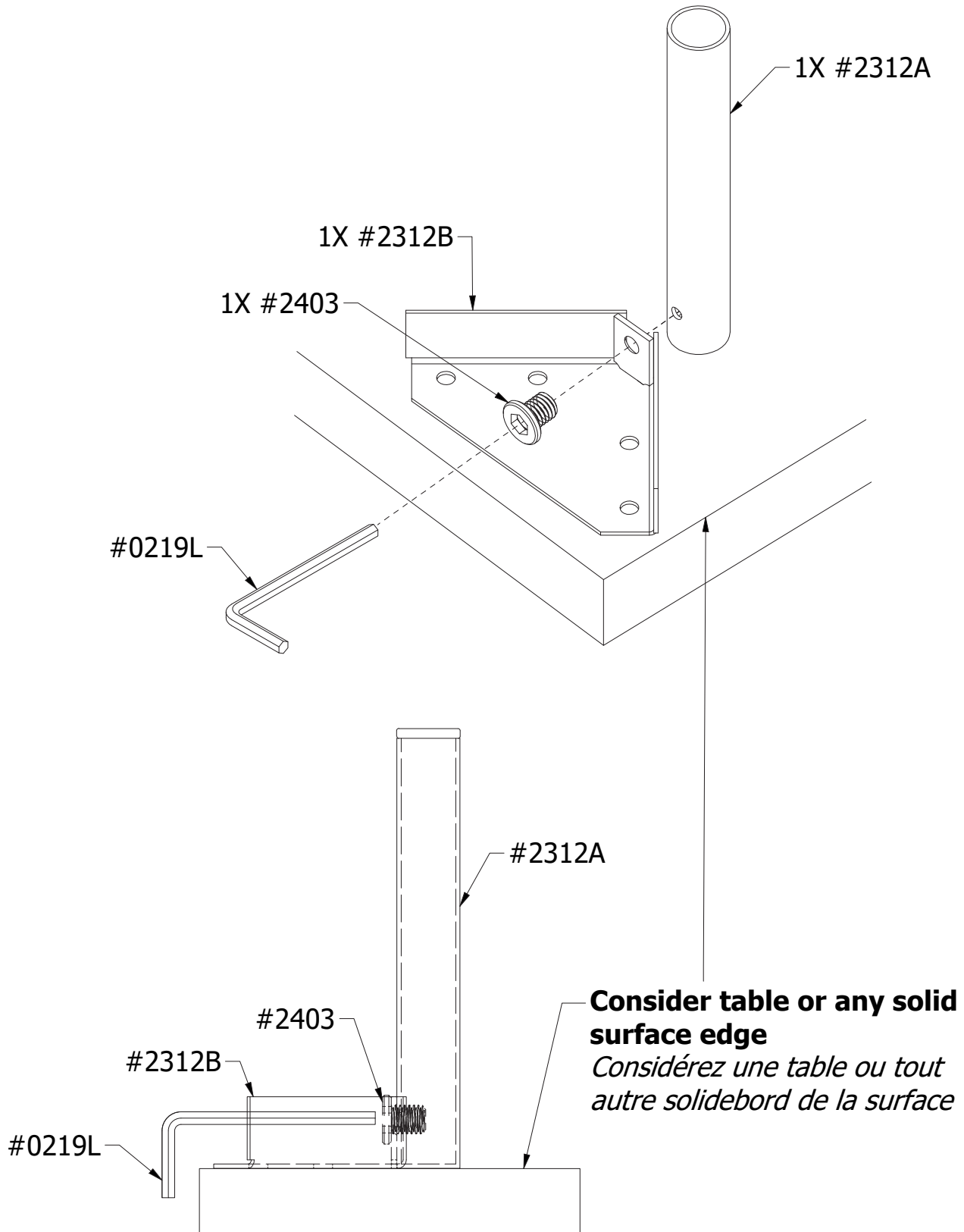

## **STEP/Étape : 7**

**Use the 8 screws # 2215 to fasten the 2 legs # 2312 to the TV Stand. Refer to the 4 pre-drilled holes to locate each leg**

*Utilisez les 8 vis # 2215 pour fixer les 2 pieds # 2312 au support TV  
Référez-vous aux 4 trous prépercés pour localiser chaque pied*

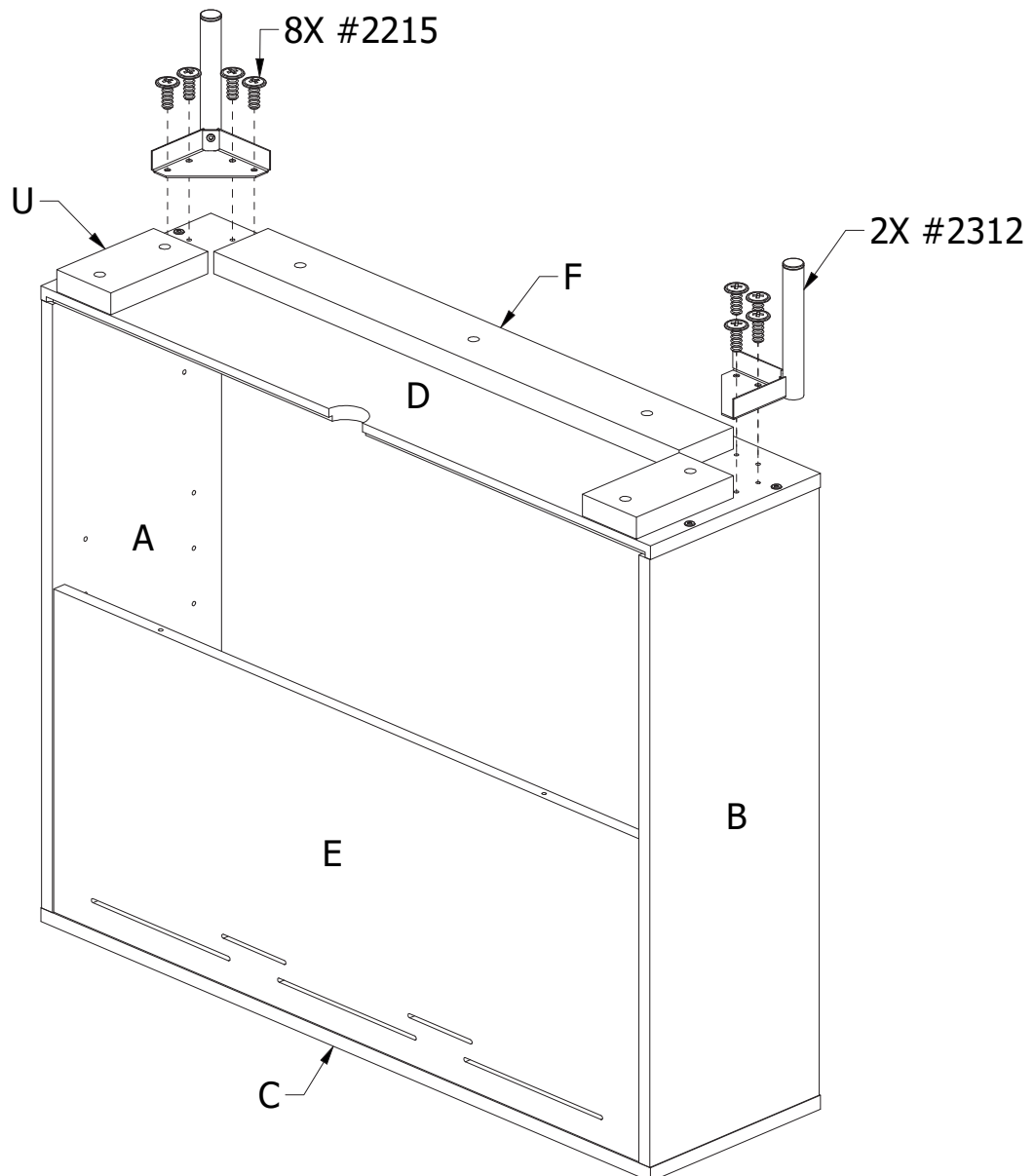

## STEP/Étape : 8

**Use a stud sensor to locate the structural studs of the wall. Then, use 2 long screws #2402 to strongly fasten the table to the wall**

*Utilisez un détecteur de montants pour localiser les montants structurels du mur. Ensuite, utilisez 2 longues vis #2402 pour fixer solidement la table au mur.*

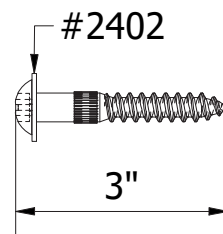
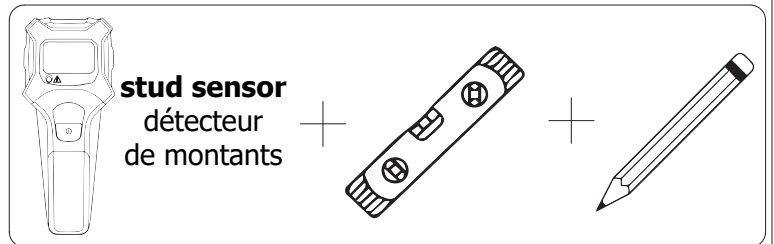
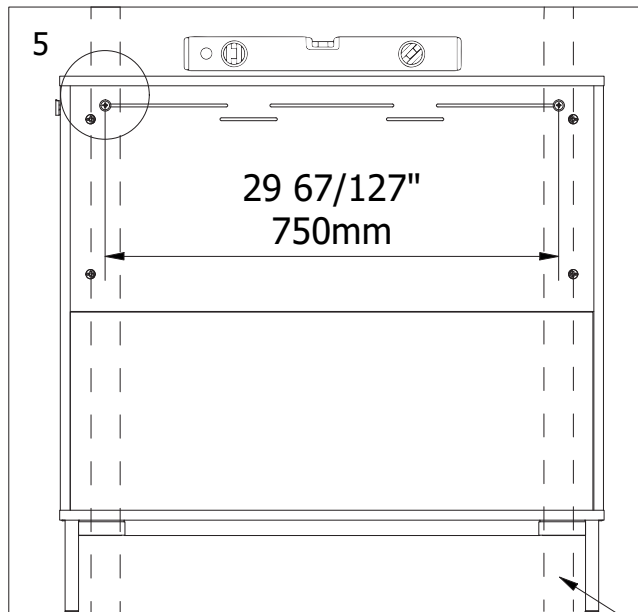

**Attach to your wall  
with the proper anchor device  
designed for your type of wall**

*Fixez à votre mur  
en utilisant une vis appropriée  
et conçue pour votre type de mur*

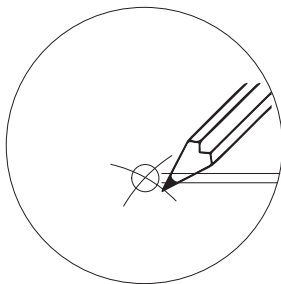

**Wall studs**  
*Montants  
muraux*

5 (2X)

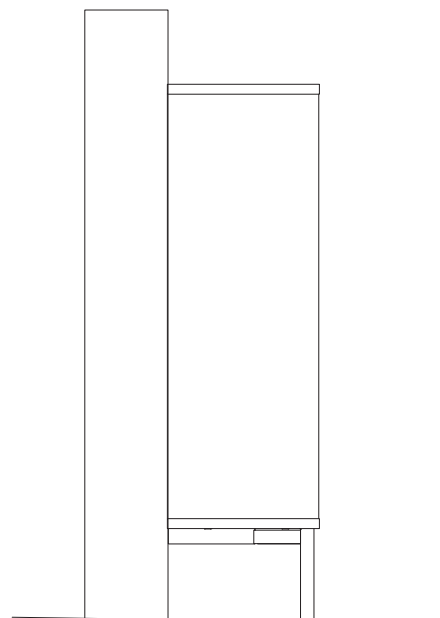
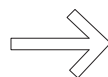
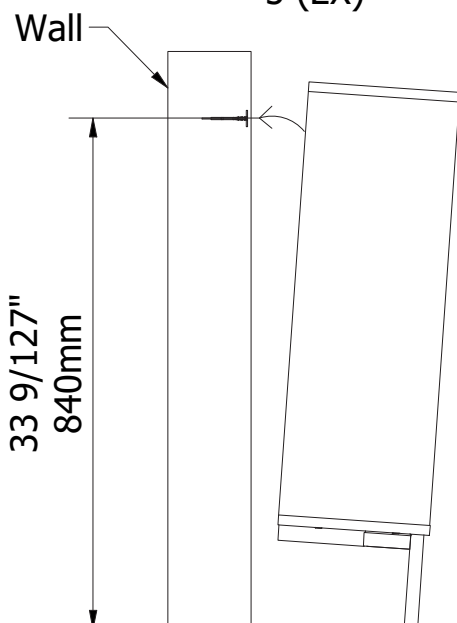
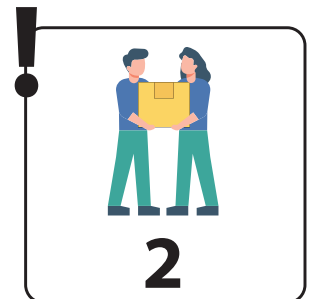

## **STEP/Étape : 9**

**Place the fibrex Below panel E. Then install the 2 supports # 1110 into the panel E**

*Placez le fibrex sous le panneau E. Installez ensuite les 2 supports # 1110 dans le panneau E*

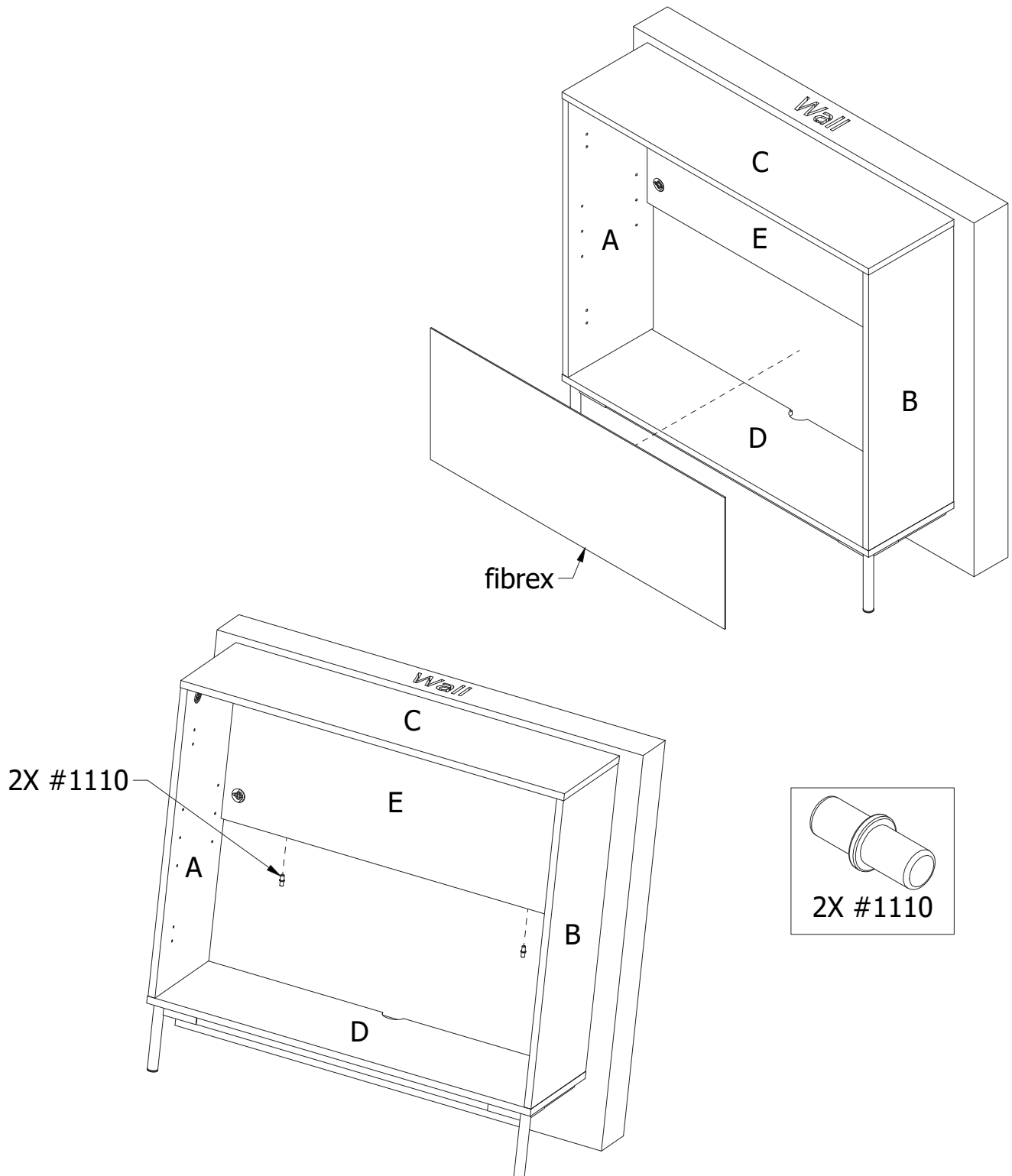

## **STEP/Étape : 10**

**Install the 4 shelf supports # 1110 into the panels A and B. Then, place the 1 adjustable shelf S into the unit**

*Installez les 4 supports d'étagères # 1110 dans les panneaux A et B. Ensuite, placez l'étagère réglable S dans l'unité*

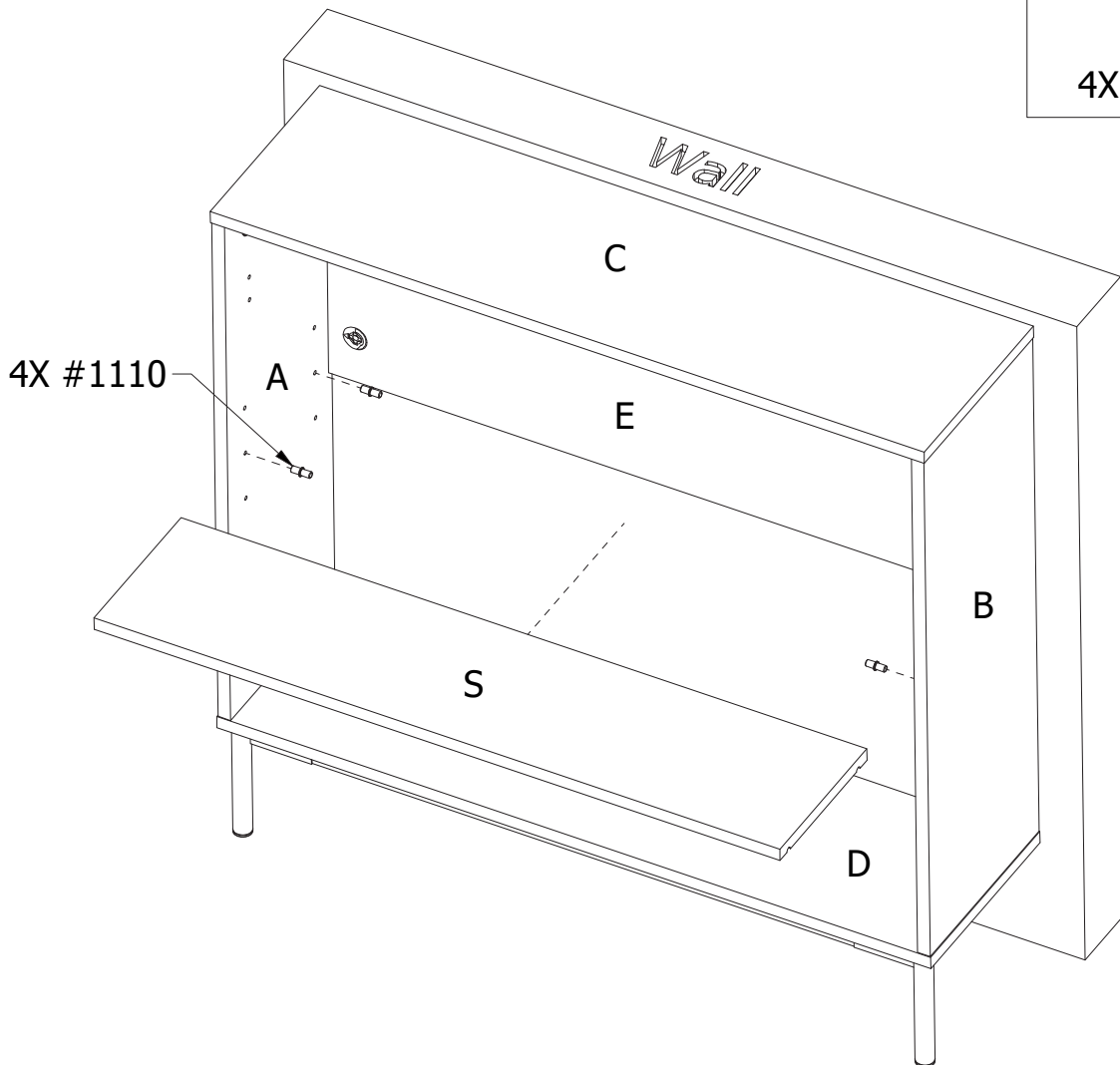
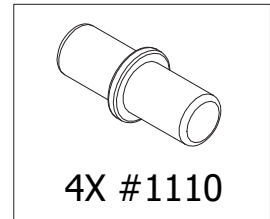

# STEP/Étape :11

**Fasten the 4 hinges # 0405 to the 2 doors X**

*Fixez les 4 charnières # 0405 aux 2 portes X*

**Elbow here**  
*Coudé ici*

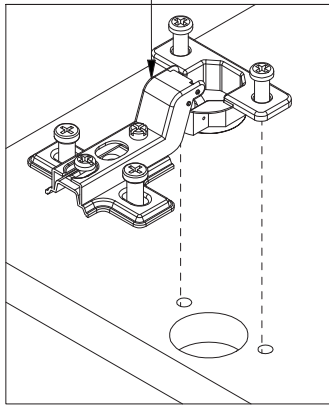

3

4X #0405

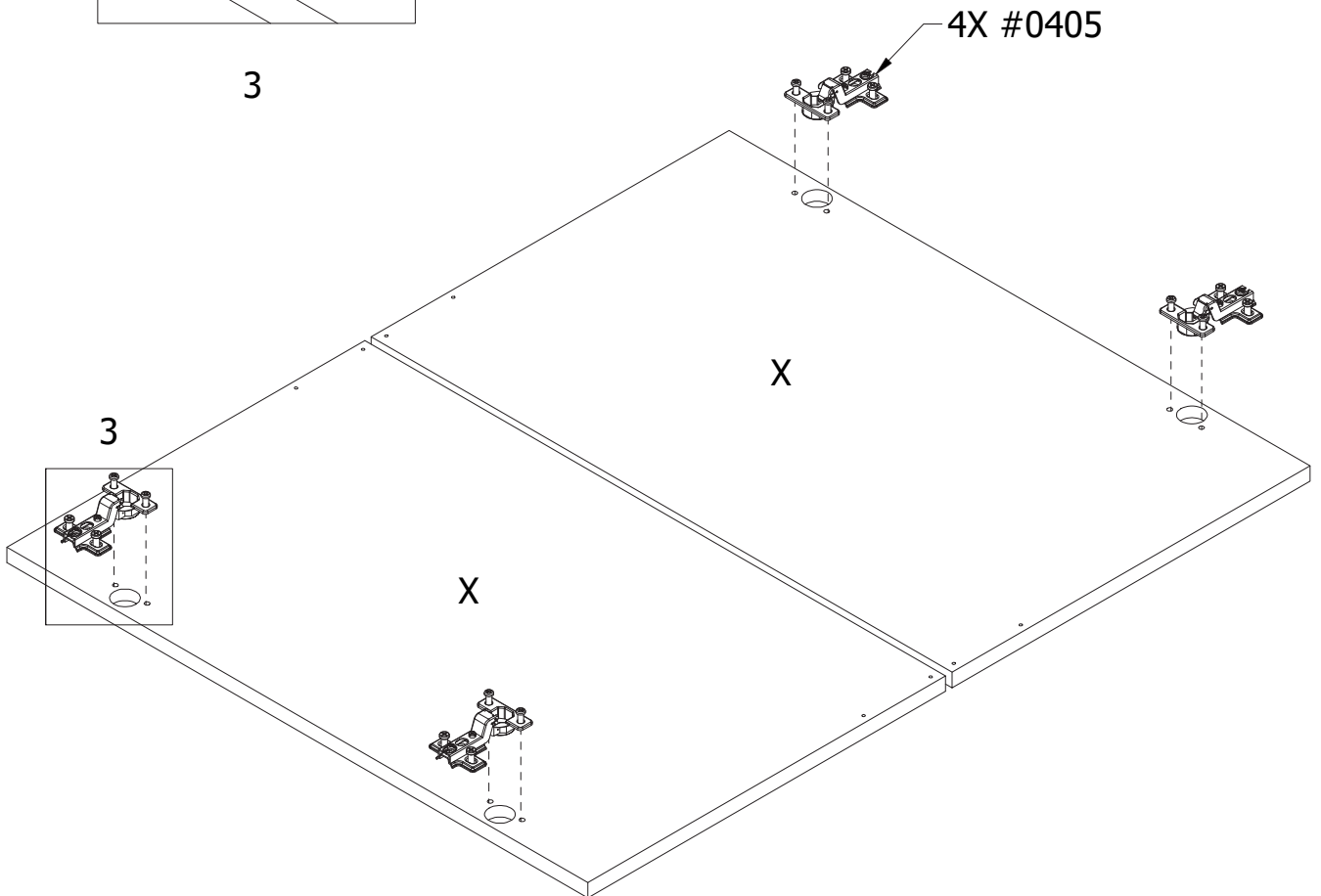

3

## **STEP/Étape : 12**

**Fasten the 2 doors X to the panels A and B. 2 screws per hinge must be tightened**

*Fixez les 2 portes X aux panneaux A et B. 2 vis par charnière doivent être serrées*

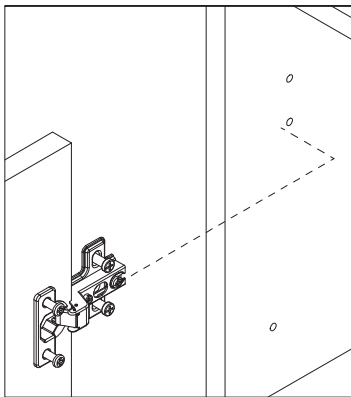

4

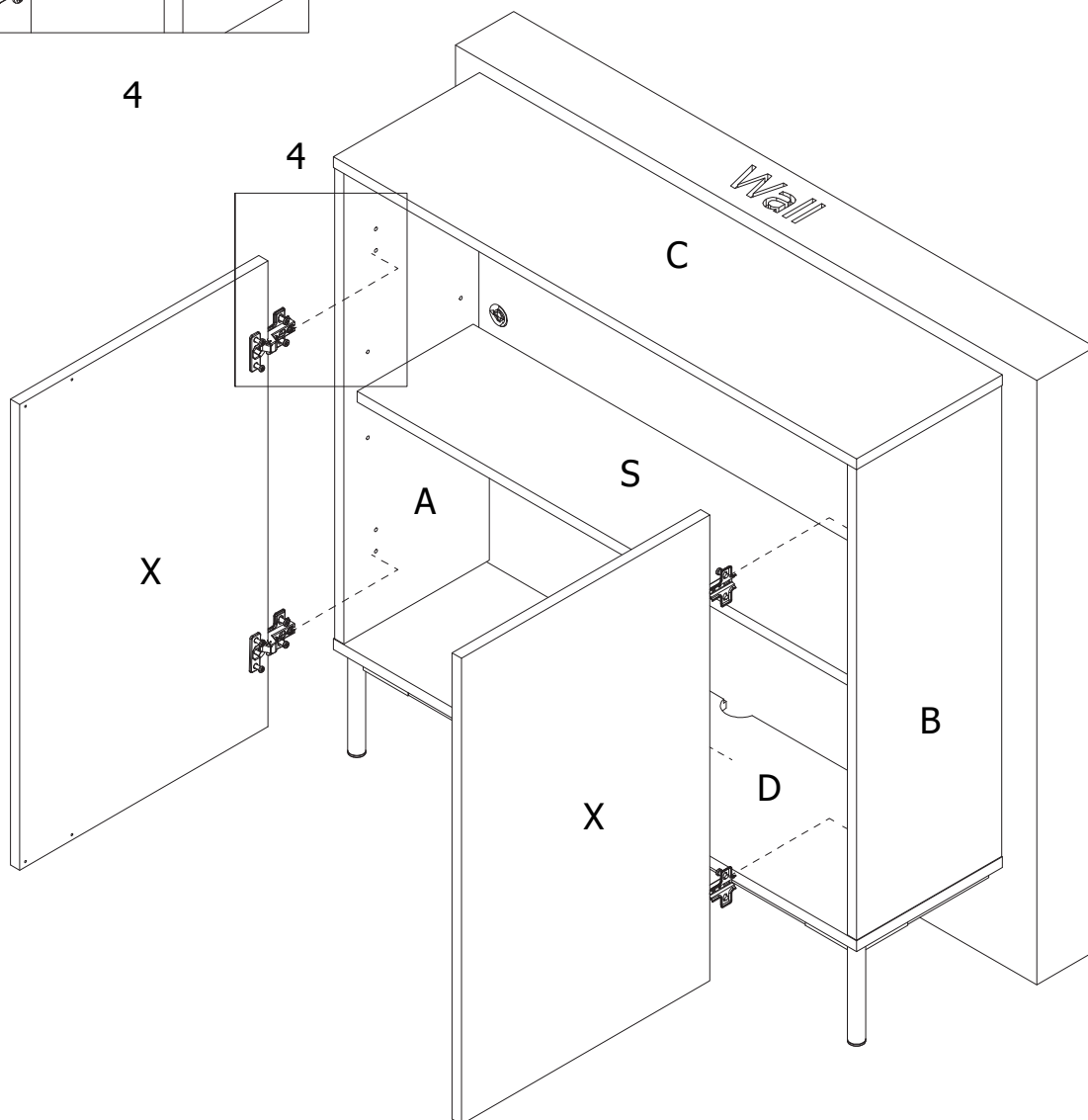

## **STEP/Étape : 13**

**Assemble the # 2401 to the doors X. Then add 1 bumper # 0527 on each door as shown**

*Assemblez le # 2401 aux portes X. Ajoutez ensuite 1 pare-chocs # 0527 sur chaque porte comme indiqué*

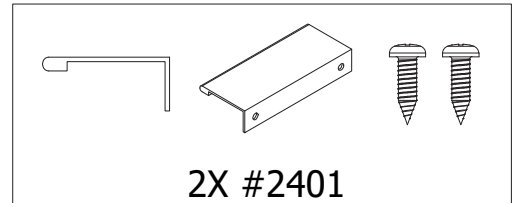
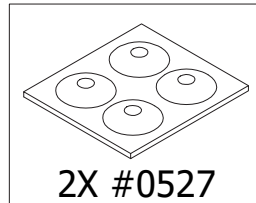

**Fasteners are include with Handle package**

*Les attaches sont incluses avec le paquet de poignées*

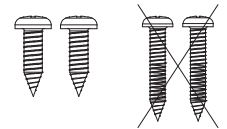

**Do not use long screw**  
*Ne pas utiliser vis longue*

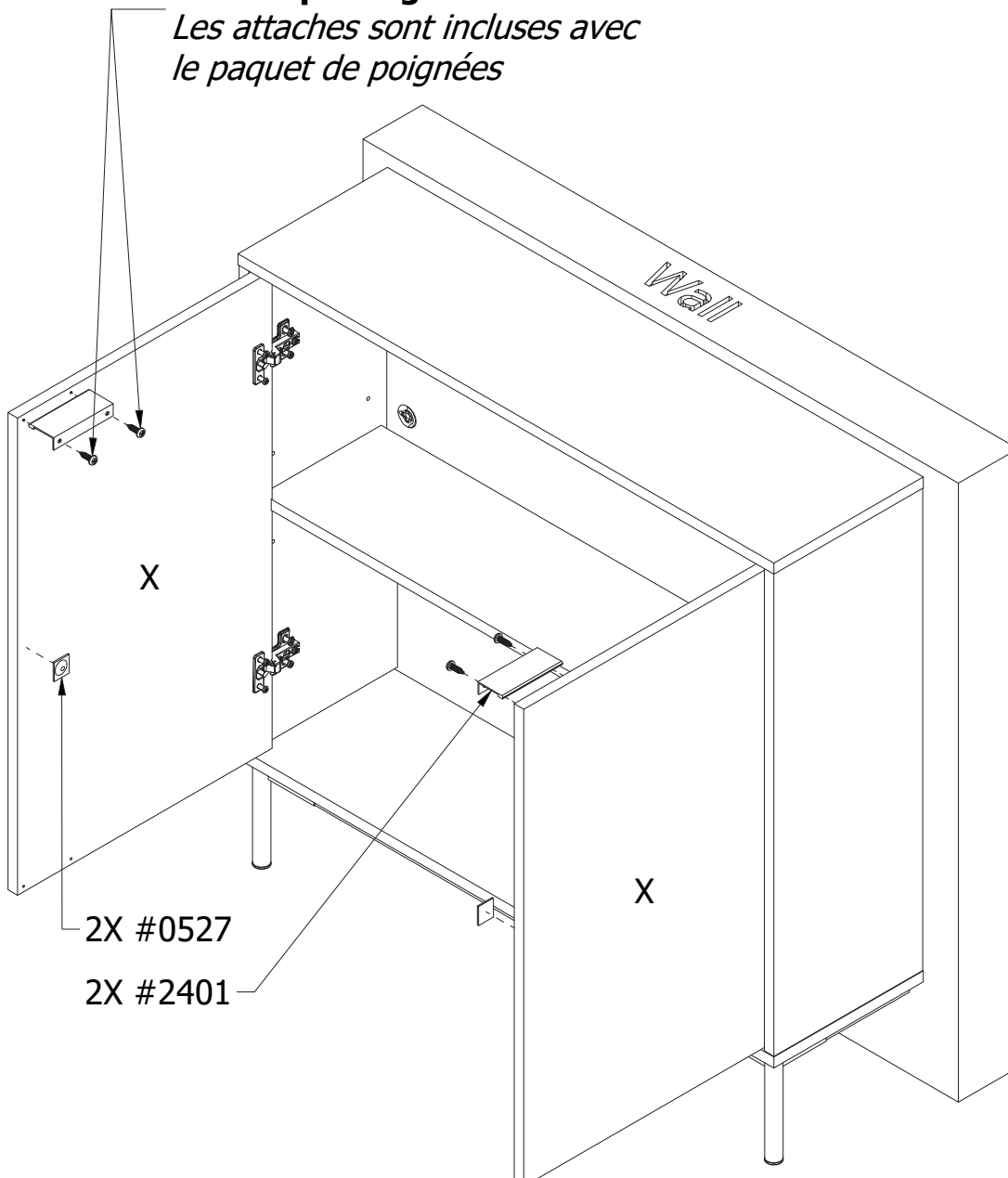

## **STEP/Étape : 14**

**Follow the 3 steps to adjust the 2 doors X**

*Ajustez les 2 portes X en suivant les 3 étapes*

**1**

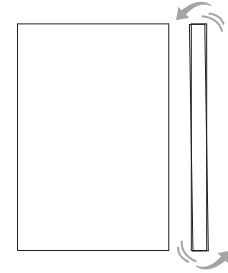
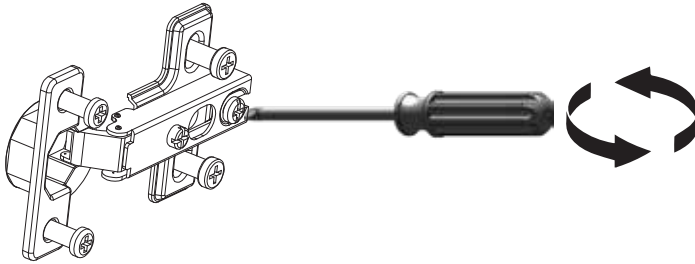

**Depth**  
*Profondeur*

**2**

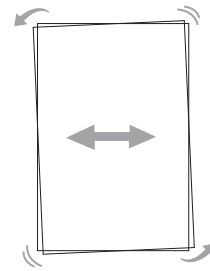
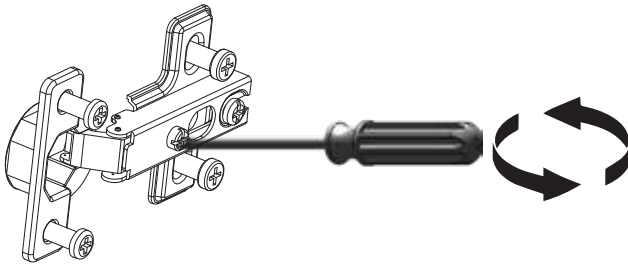

**Horizontal  
adjustment**  
*Ajustement  
horizontal*

**3**

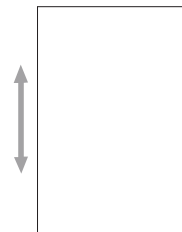
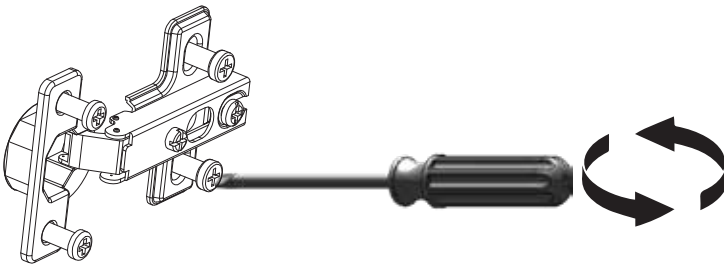

**Height**  
*Hauteur*



## Limited 1 Year Warranty

All products are warranted to the original purchaser against defects in material or workmanship for a period of 1 year from the date of purchase.

"Defects" as used in this warranty is defined as any imperfections that may impair the use of the furniture or product for which it was intended to.

This warranty is expressly limited to the replacement of defective furniture parts and/or components, subject to availability of stock. Assembly labor is excluded.

This warranty applies under conditions of normal use. It does not cover defects caused by improper assembly or disassembly, product modification, intentional damage, abuse, misuse, accidents, negligence or exposure to the elements. Our furniture products are not intended for outdoor use.

This warranty is only applicable in Canada and the USA.

We reserve the right to request proof of purchase from an authorized retailer as well as any other proofs to document a warranty claim.

This warranty is explicit on the limits of our liability and entitles the original purchaser to specific rights. Any warranty defined by law in your state/province is limited to 1 year. Should the law in your state or province differ from the above, it will not apply.

## **Garantie limitée de 1 an**

*Tous les produits sont garantis à l'acheteur original contre toutes déficiences de matériel ou de fabrication pour une période de 1 an à partir de la date d'achat.*

*Le mot "déficiences" utilisé dans cette garantie signifie toutes imperfections pouvant nuire à l'utilisation du meuble ou du produit pour lequel il a été conçu.*

*Cette garantie est expressément limitée au remplacement des pièces ou composantes défectueuses, sujet à la disponibilité des stocks. La main d'œuvre de l'assemblage est exclue.*

*Cette garantie s'applique dans des conditions d'utilisation normales. Elle ne couvre pas des déficiences résultant d'un assemblage ou désassemblage défectueux, modification du produit, dommages intentionnels, abus, usage impropre, accidents, négligence ou des expositions aux éléments extérieurs. Nos meubles ne sont pas destinés pour une utilisation à l'extérieur.*

*Cette garantie s'applique uniquement au Canada et aux États-Unis.*

*Nous se réserve le droit d'exiger une preuve d'achat ou toutes autres pièces justificatives pour valider cette garantie.*

*Cette garantie est limitative quant à la responsabilité de nos et donne à l'acheteur original des droits spécifiques. Toute garantie législative prévalant dans votre lieu de résidence est limitée à une période de 1 an. Lorsque la législation de votre lieu de résidence diffère de celle-ci, elle ne s'appliquera pas.*