

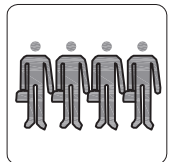

akville

OF-950S05 8x12

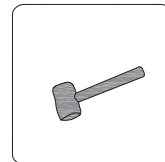
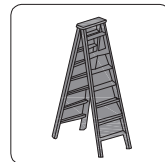
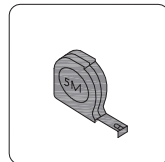
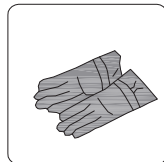
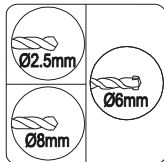
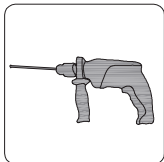
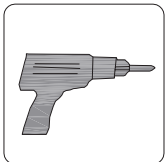

Assembly Preparation

Owner's Manual

Please check local building codes regarding footings, location and other requirements before beginning construction.

Assembly instructions:

Reviewing all instructions and the appropriate information before you begin, make sure following the step sequence carefully for successful results.

Flooring base:

A good location for the storage building is a square and level area with good drainage. The base is not included in the kit which may need purchase separately or may construct a foundation and anchoring system of your own. The foundation base should be 10 cm larger than the base rail of the shed (minimum 10cm thickness concrete slab is recommended).

A strong plastic sheet (thickness: at least 150µm) should be placed under the foundation to assist in reducing rising dampness from the soil, thus reducing condensation build up in the shed. Your storage building must be anchored to prevent wind damage.

Parts and Parts List:

Before you start, check to be sure that you have all the necessary parts for your building (refer to the Parts List Page). Do not attempt to assemble the building if parts are missing because any building left partially assembled may be seriously damaged by light winds.

Please tear off the safety protection layer before assembly, keep the part number label if needed.

Tools you need:

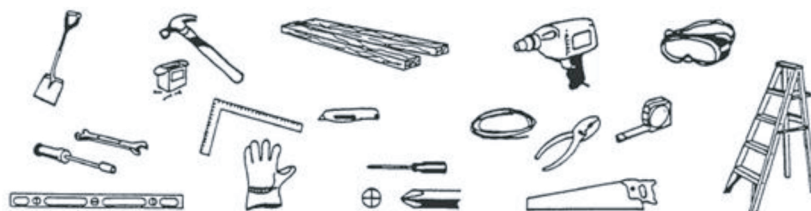

Safety must be put in the No. 1 position:

1. Select a dry and calm day for your assembly. Team works (Two or more people) are required during the assembly. It is also recommended to finish the assembly in a day to avoid damage to the product or missing of some small parts. Keep all small parts (screws etc.) in a bowl so they do not get lost.
2. Wearing safety gloves, eye protection and long sleeves during the assembly to prevent injury. Pay attention to the sharp edge of some parts.
3. Children and pets are not allowed entering into the construction site.
4. Never concentrate your total weight on the roof of the building. When using a step ladder make sure that it is safe.

Care & Maintenance:

1. Keep the shed clean with soft cloth, use water if necessary.
2. Clean the snow timely with necessary tools to make sure it is safe to enter into.
3. The shed is not made for living but storing stuff.









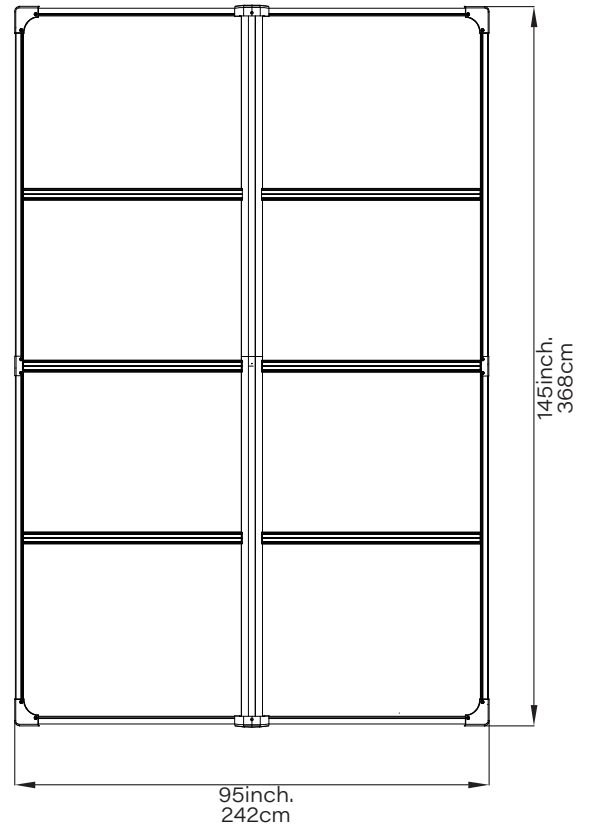
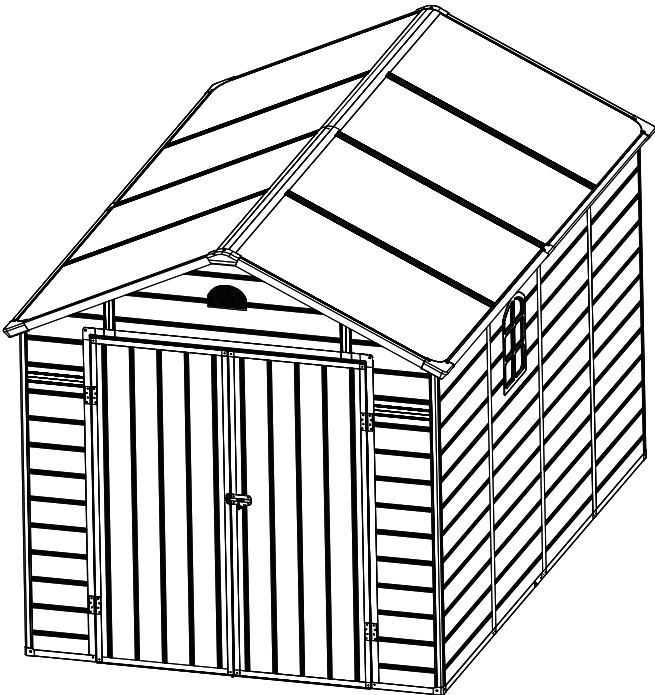
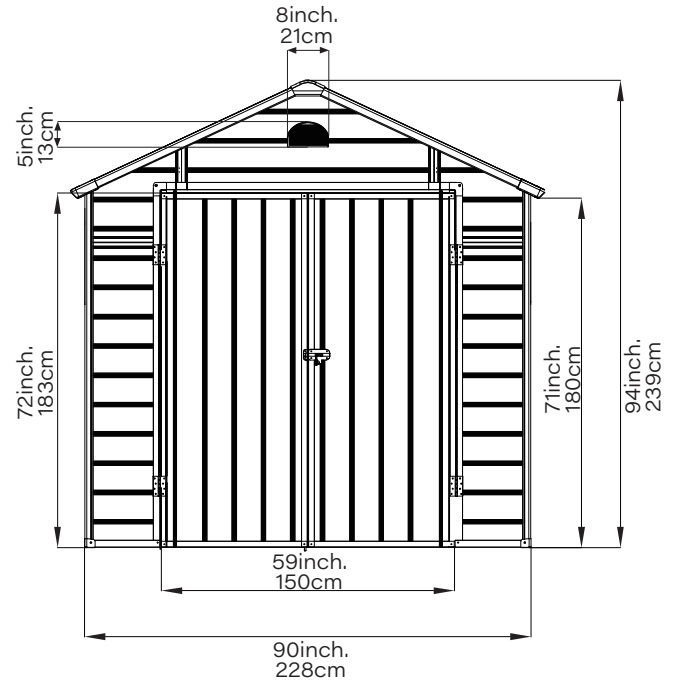
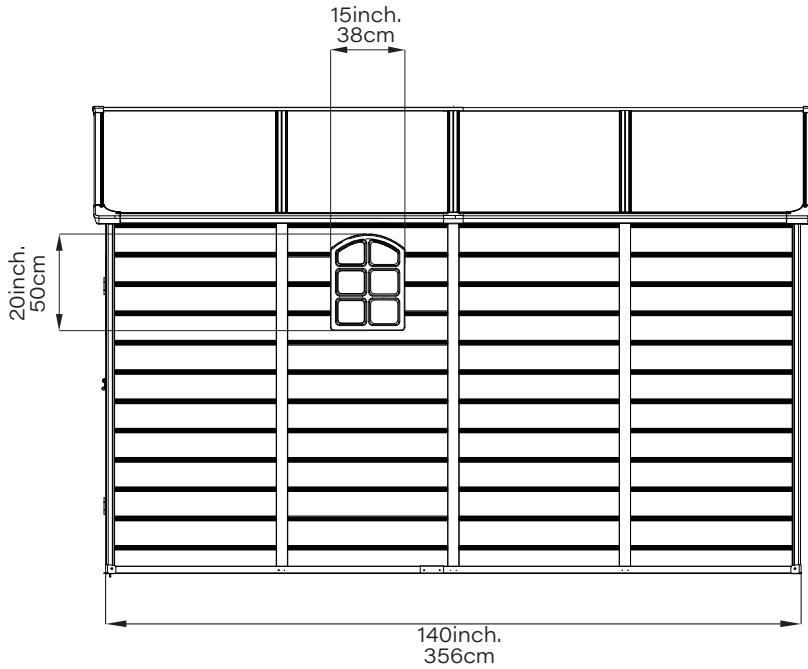

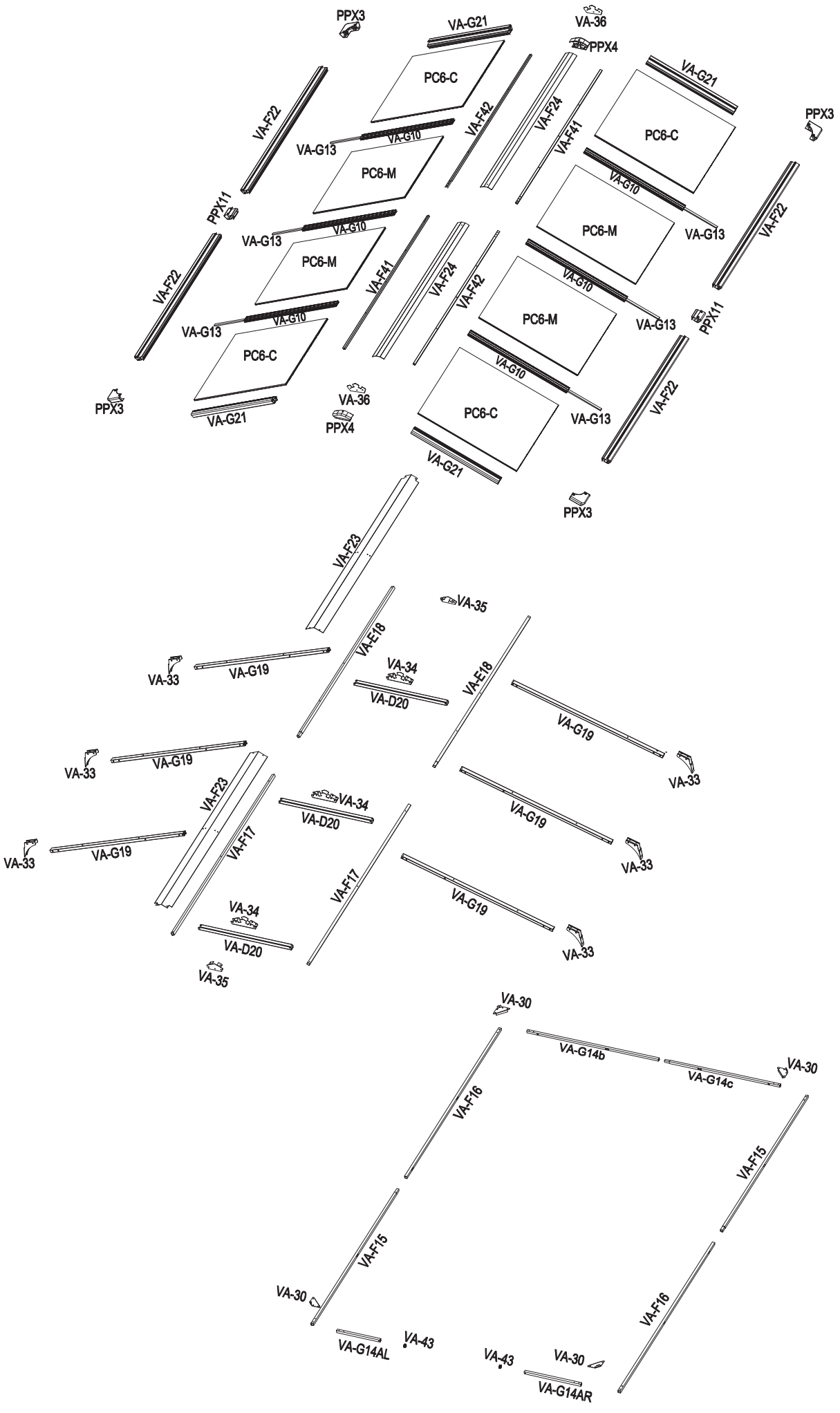





















akville















































SIZE







OF - 950S05



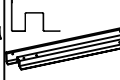

			
VA-G1L		1132mm	x1
VA-G1R		1132mm	x1
VA-F2R		1880mm	x2
VA-F2L		1660mm	x2
VA-G3R		377mm	x1
VA-G3L		377mm	x1
VA-E2M		120mm	x3
VA-G4		1588mm	x1
VA-30			x8
VA-31			x4
VA-37b			x8
			
PB1		876x1840mm	x7
PB1S		876x1840mm	x1
PC2S		1270x542mm	x1
PC2L		461x493mm	x1
PC2R		461x493mm	x1
PC3L		743X1072mm	x1
PC3R		743X1072mm	x1
PC3S		743X1248mm	x1
PC4		743X1100mm	x3
PC5		365X1548mm	x2
VA-C7R		1860mm	x2
VA-C7L		1860mm	x2
VA-C5		1840mm	x8
VA-C5c		365mm	x2
VA-C6b		200mm	x2
PPX12			x1
W2S			x1
PPX13			x1
VA-G8		738mm	x3
VA-G9		360mm	x2
VA-G9b		254mm	x2
VA-G11		740mm	x3
VA-G12		362mm	x2
VA-G12b		225mm	x2
VA-G14b		1200mm	x1
VA-G14c		1052mm	x1
VA-G14AL		345mm	x1
VA-G14AR		345mm	x1
VA-F15		1850mm	x2
VA-F16		1678mm	x2
VA-F17		1857mm	x2
VA-E18	1745mm	x2	
VA-G19		1181mm	x6
VA-D20		725mm	x3
VA-33			x6
VA-34			x3
VA-F23		1788mm	x2

VA-36			x2
VA-32R			x2
VA-32L			x2
VA-35			x2
PPX14			x2
PPX8			x2
PPX9			x2
VA-43			x2
			
PC6-C		1285X920mm	x4
PC6-M		1285X856mm	x4
VA-G10		1285mm	x6
VA-G13		1285mm	x6
VA-G21		1165mm	x4
VA-F22		1722.5mm	x4
VA-F24		1880.5mm	x2
VA-F41		1863mm	x2
VA-F42		1862mm	x2
PPX3			x4
PPX4			x2
PPX11			x2
			
VA-C25R		1830mm	x1
VA-C25L		1830mm	x1
VA-G26		1508mm	x1
VA-C27		1812mm	x3
VA-G28		747mm	x4
VA-C29		1812mm	x1
PC7S		1810x746mm	x2
			
VA-41			x4
VA-38a			x2
VA-38b			x2
VA-39			x2
VA-40			x1
CN-A33			x2
PA01			x3
VA-T44		ST4.2x13mm	x424
VA-T45		ST4.2x19mm	x127
VA-T46		ST4.2x13mm	x59
VA-T47		ST4.2x19mm	x4
VA-T48		ST6.0x40mm	x9
VA-T49		ST4.2x13mm	x22
VA-T50		M6x40mm	x30
VA-51			x1
VA-T52			x2
VA-53			x3
VA-55			x2
VA-55b			x1
VA-DB07		735x1740mm	x6

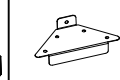
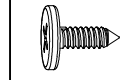

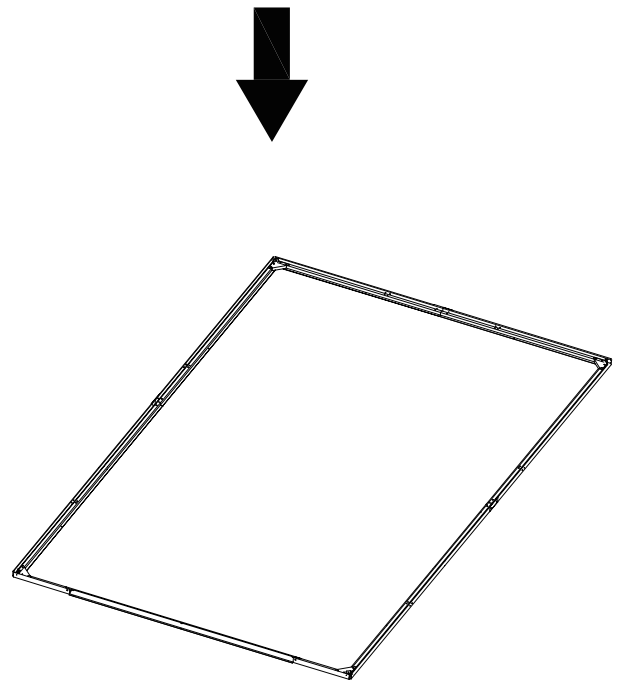
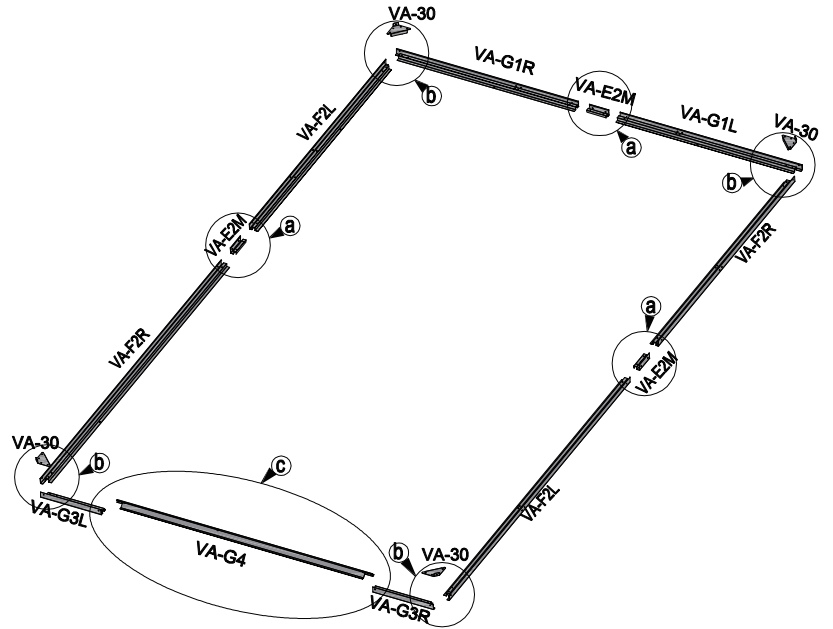
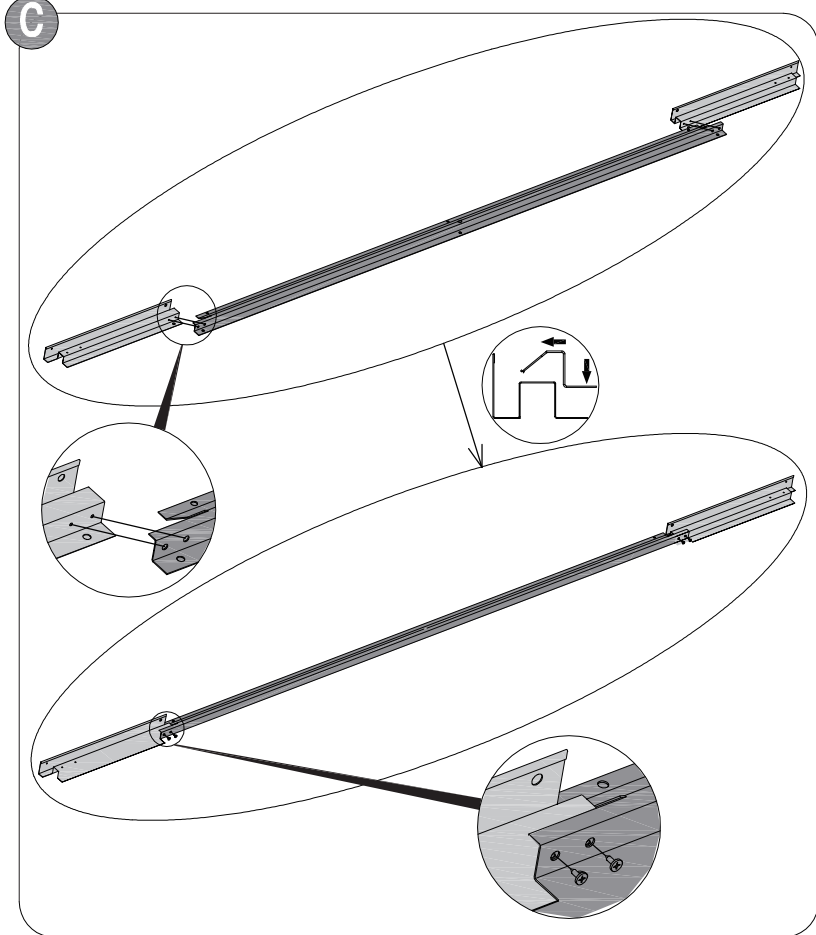
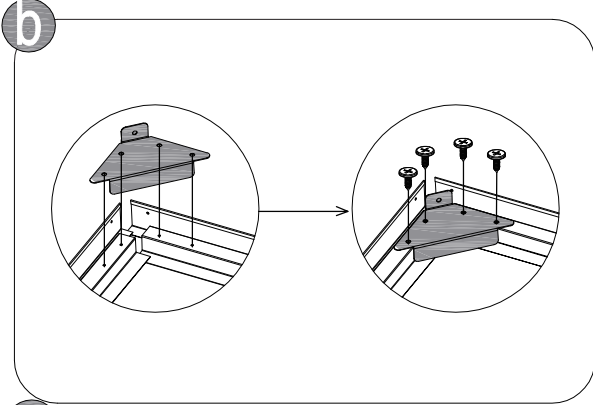
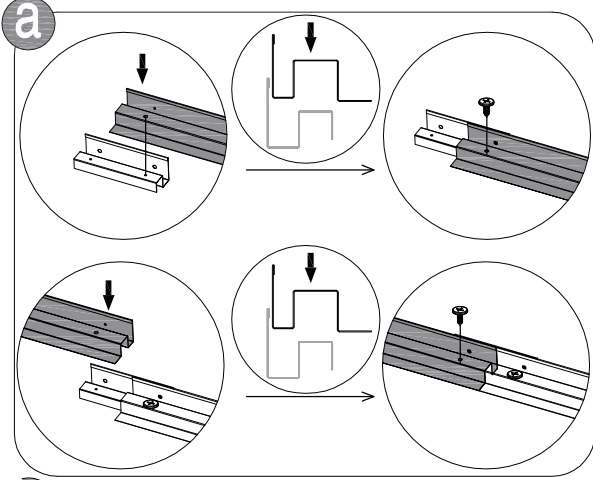

1	 VA-F2L [x2] 1660mm	 VA-F2R [x2] 1880mm	 VA-G1R [x1] 1132mm	 VA-G1L [x1] 1132mm	 VA-G3L [x1] 377mm	 VA-G3R [x1] 377mm	 VA-G4 [x1] 1588mm	 VA-E2M [x2] 120mm	 VA-30 [x4]	 VA-T44 [x26] 13mm
----------	--	--	--	--	---	---	--	---	---	---

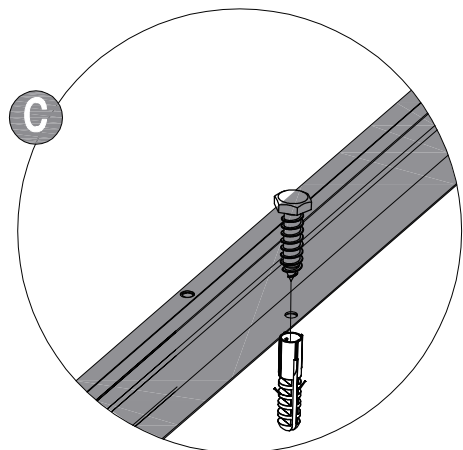
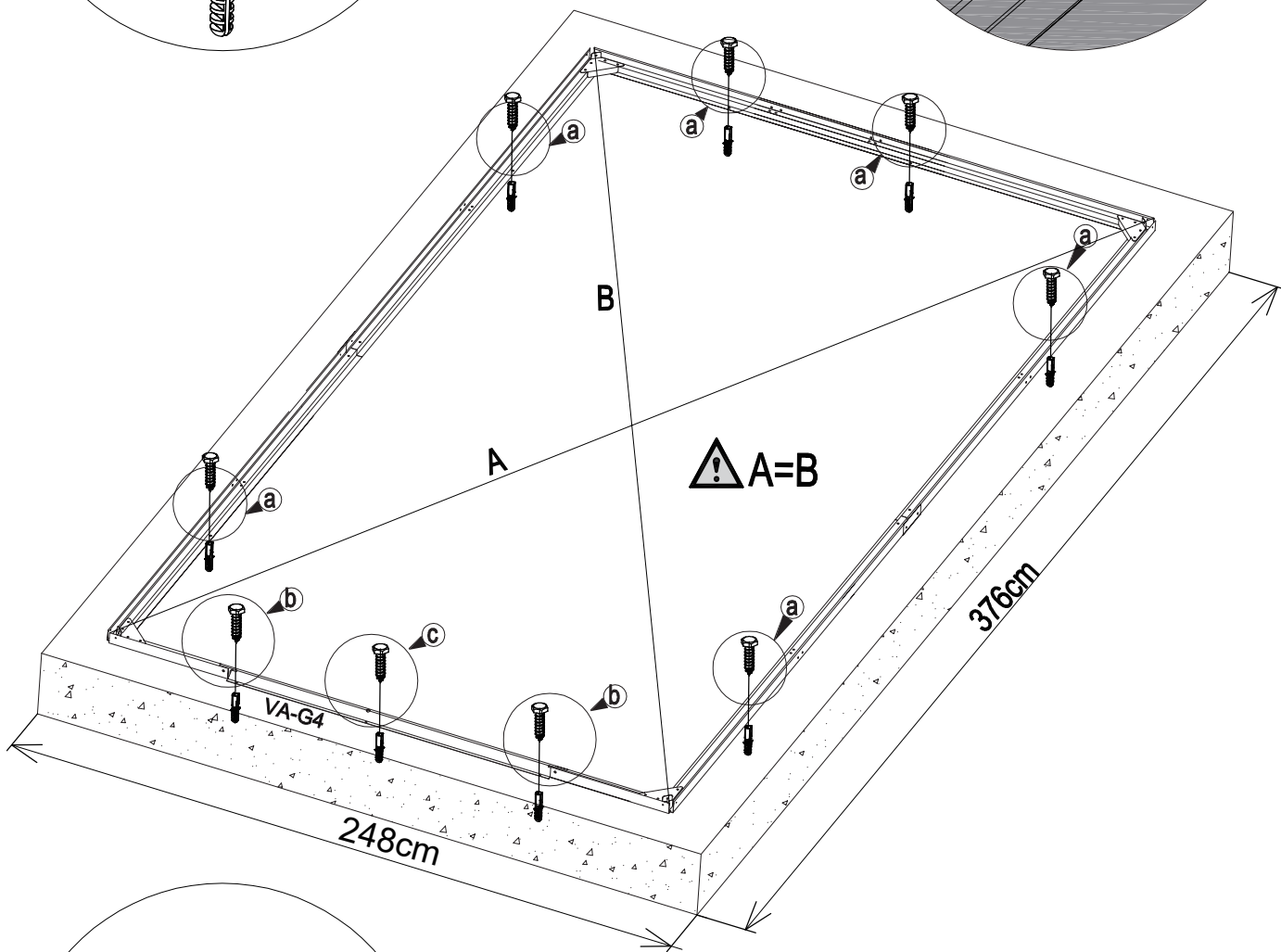
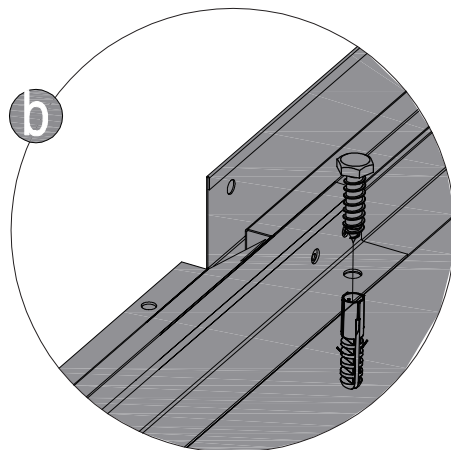
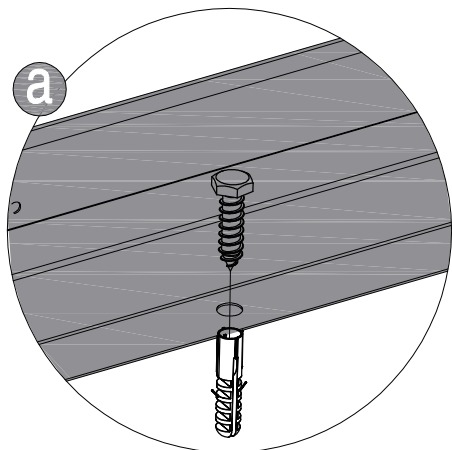

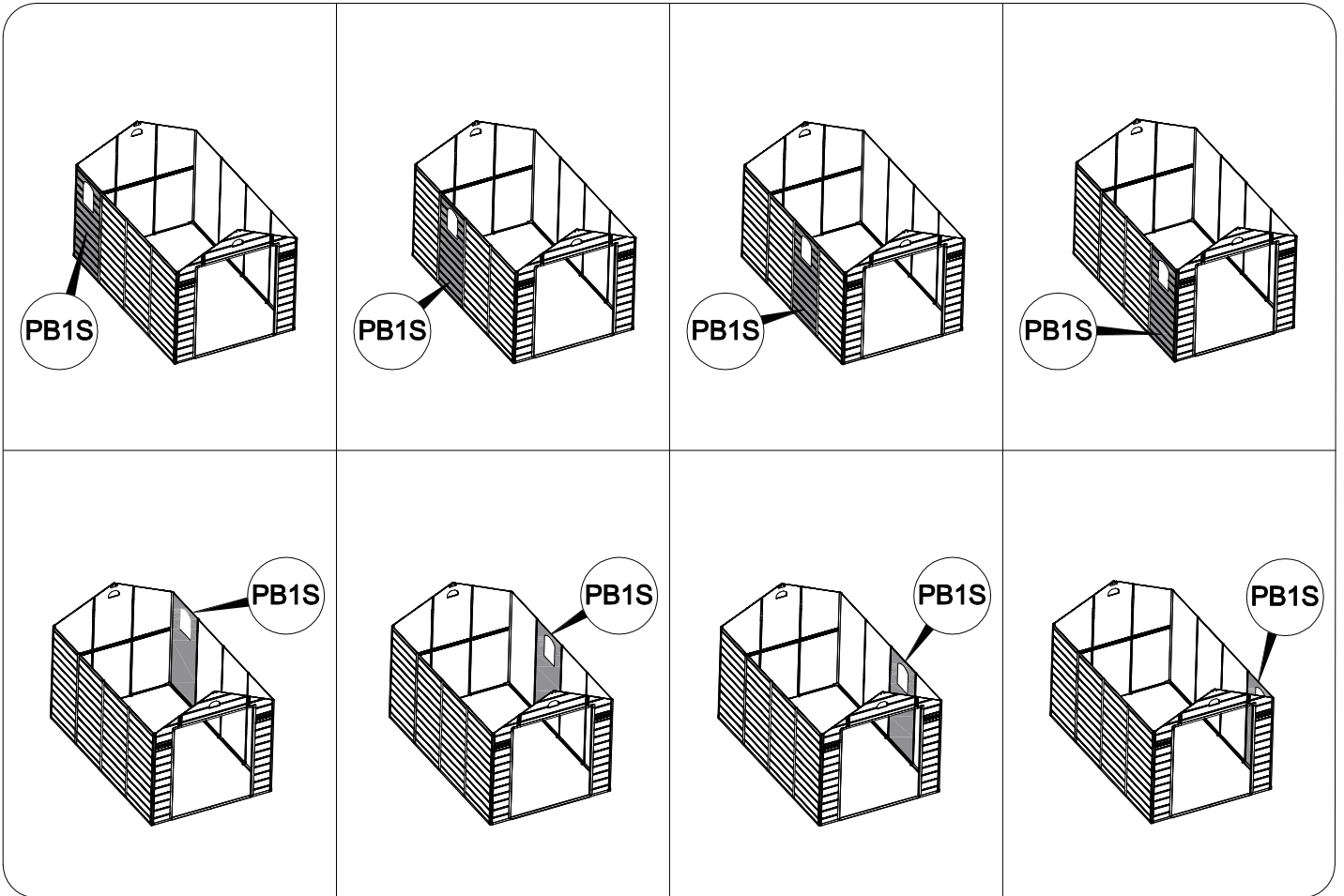

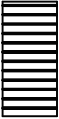

2



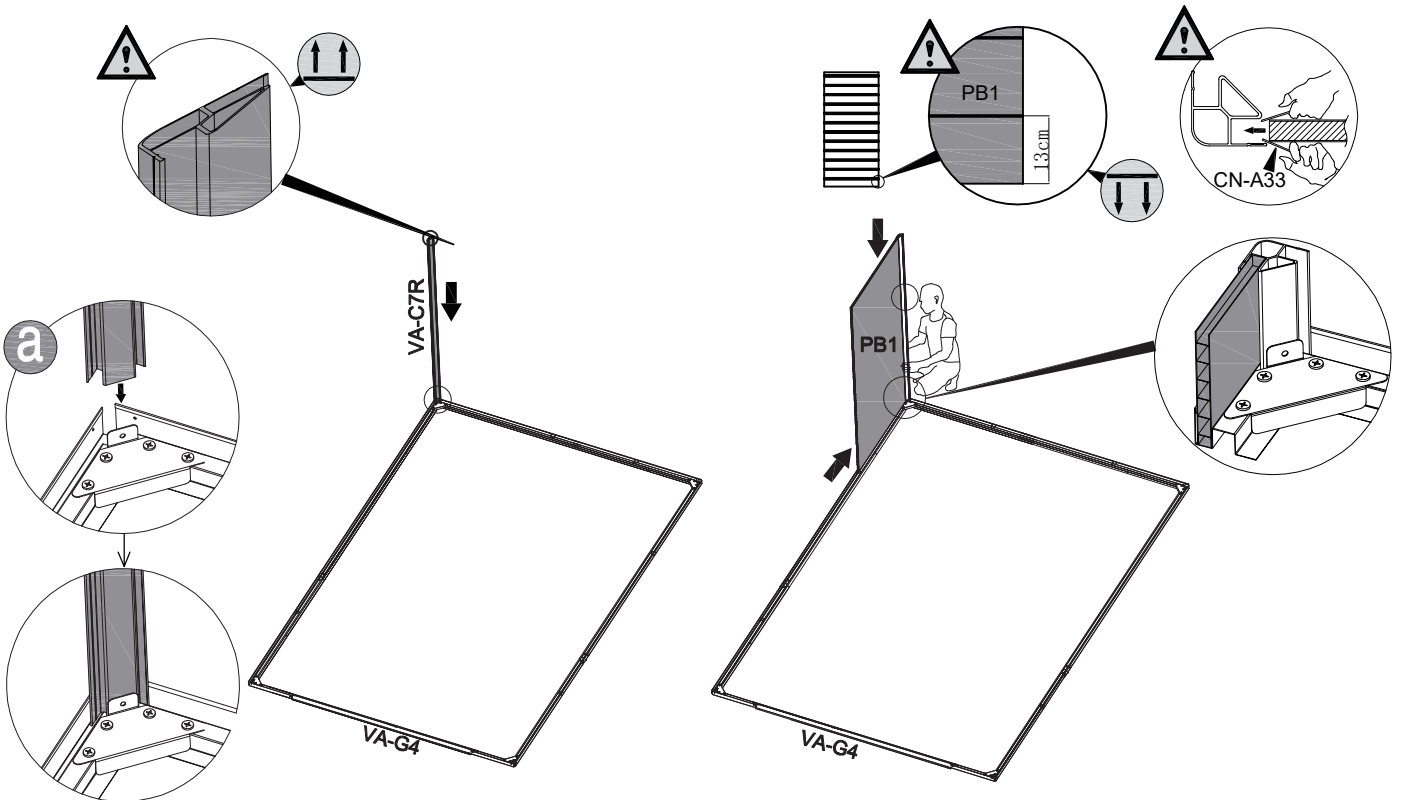





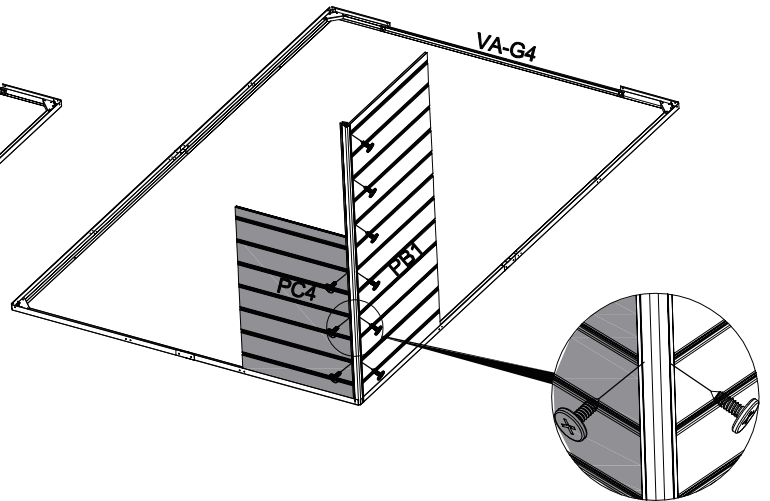
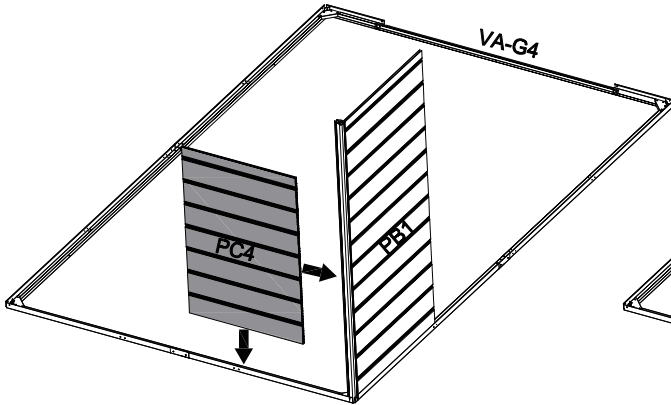
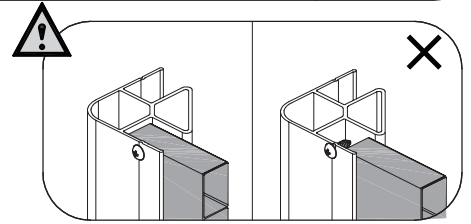
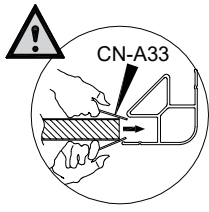
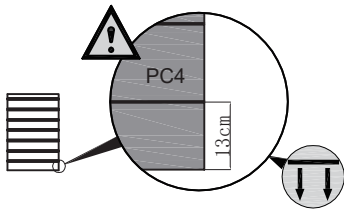

3	 PB1 [x1] 876x1840mm	 VA-C7R [x1] 1860mm	 CN-A33	
---	---	--	---	---

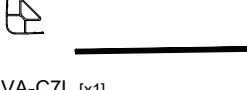



4	 PC4 [x1] 743x1100mm	 VA-T45 [x9] 19mm	 CN-A33	
----------	--	---	--	---



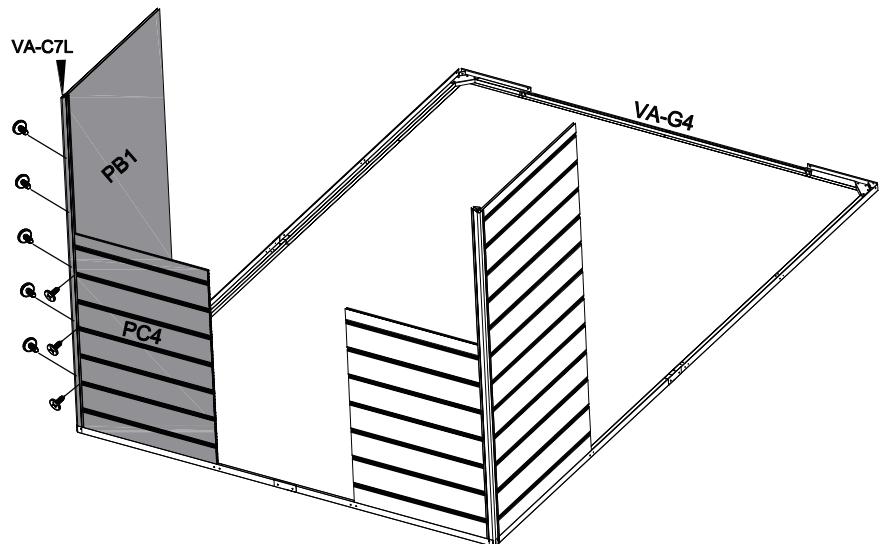
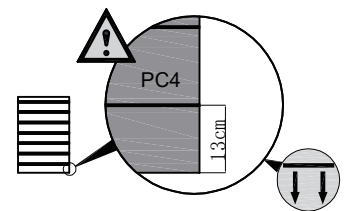
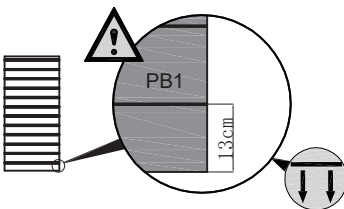
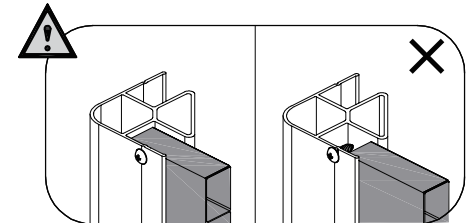
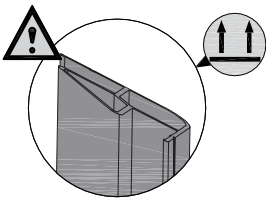



5	 VA-C7L [x1] 1860mm	 PB1 [x1] 876x1840mm	 PC4 [x1] 743x1100mm	 VA-T45 [x9] 19mm	 CN-A33	
----------	---	--	--	---	--	---

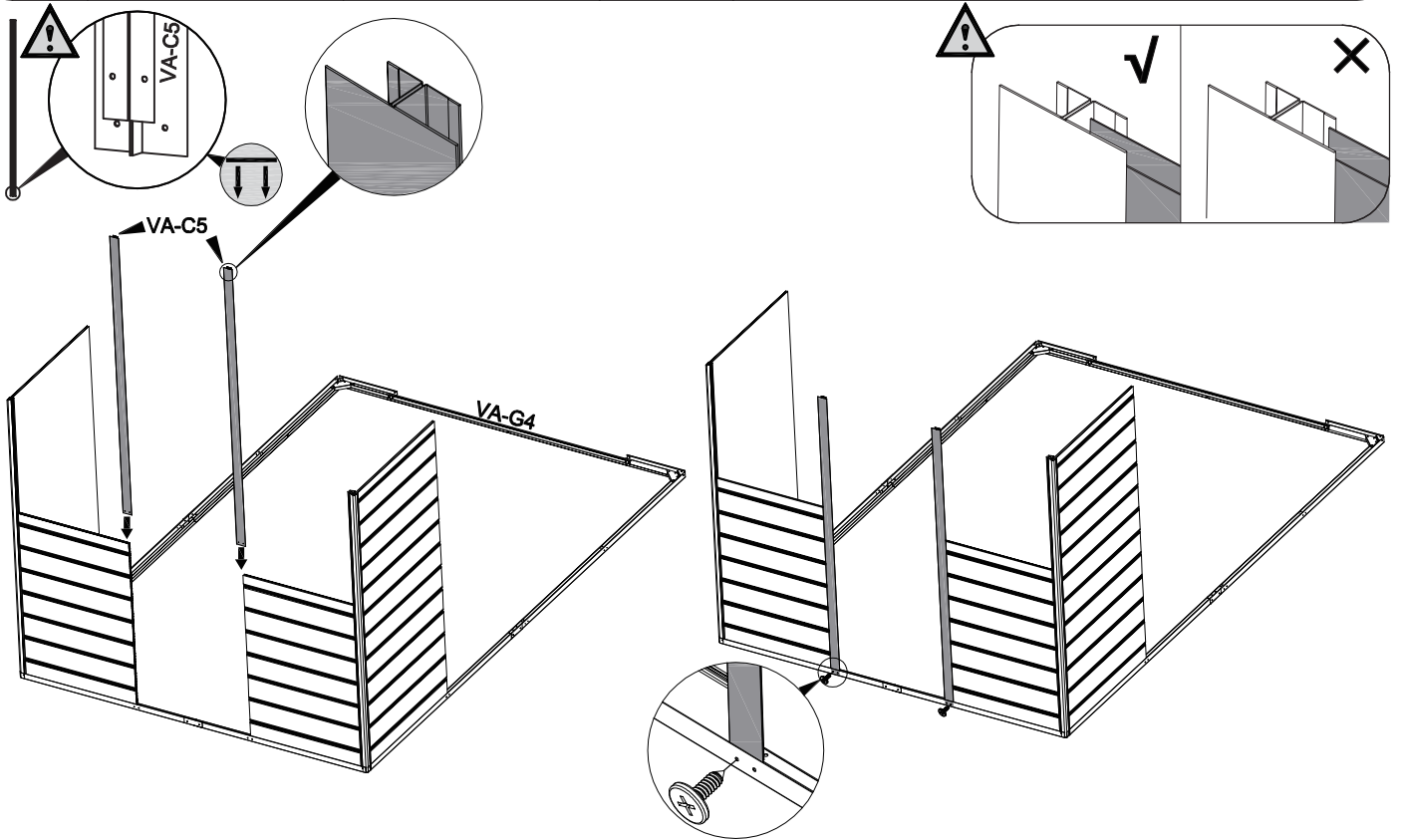

6	 VA-C5 [x2] 1840mm	 VA-T44 [x2] 13mm	 CN-A33	
----------	---	--	---	--

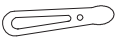

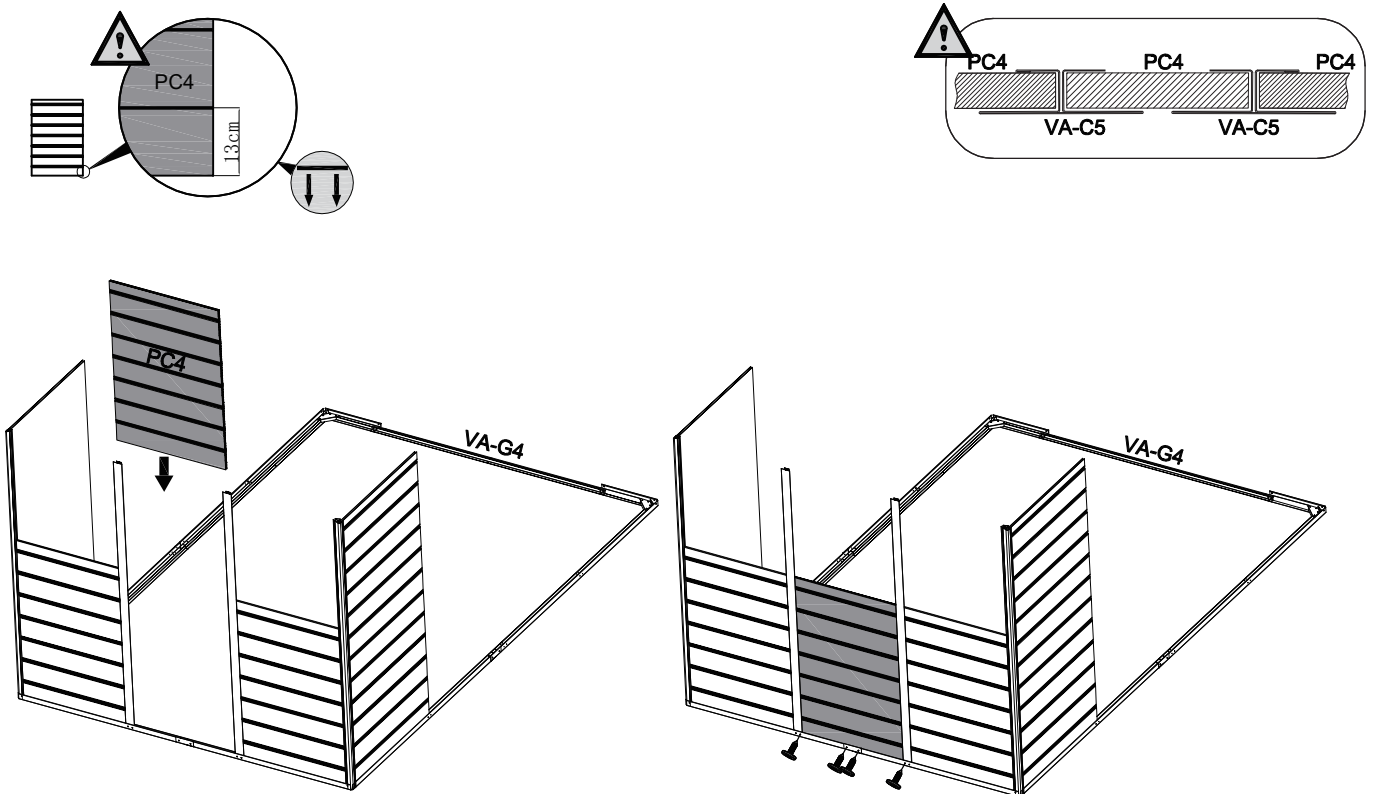

7	 PC4 [x1] 743x1100mm	 VA-T44 [x4] 13mm	 CN-A33	
----------	---	--	---	---

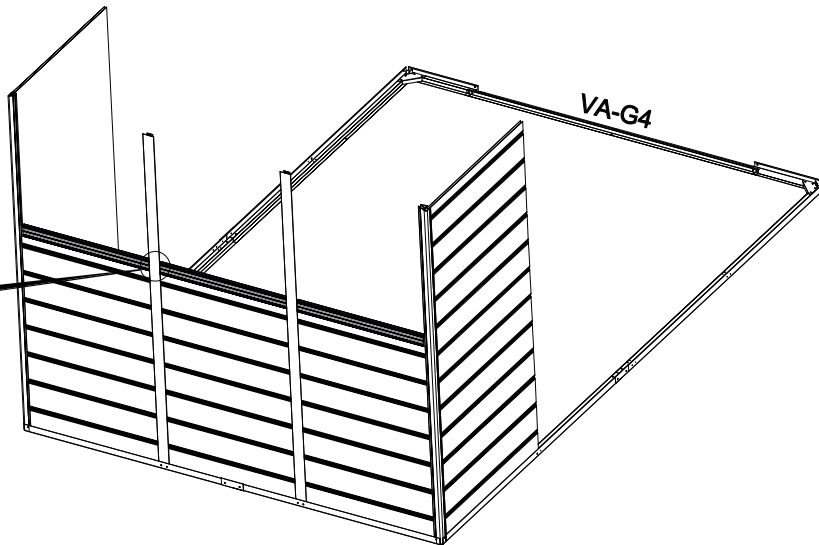
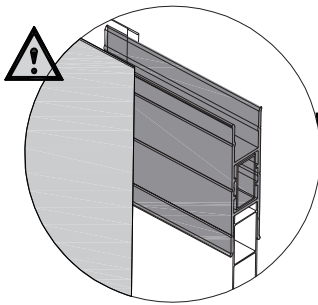
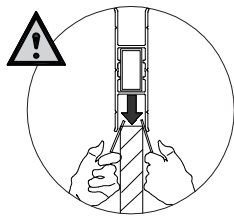
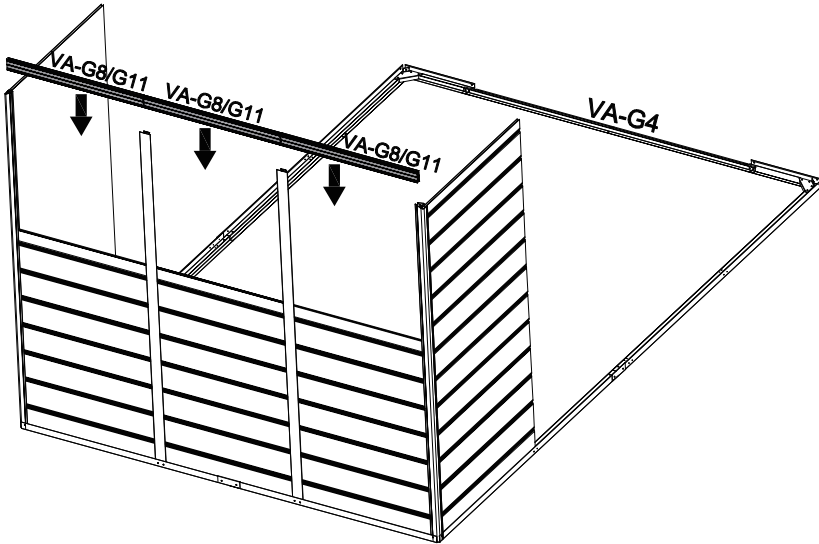
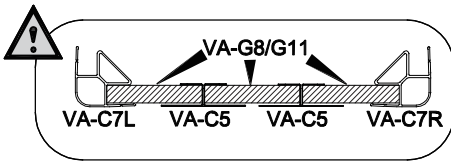
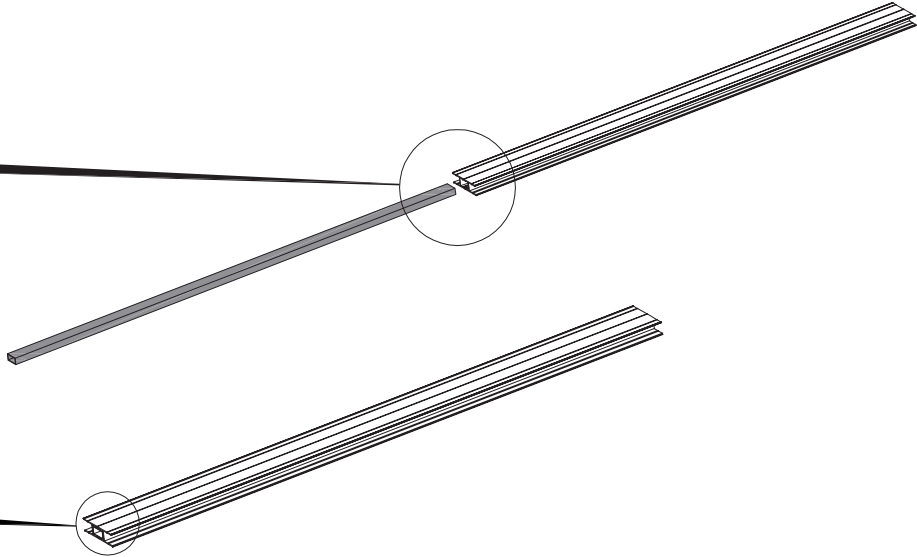
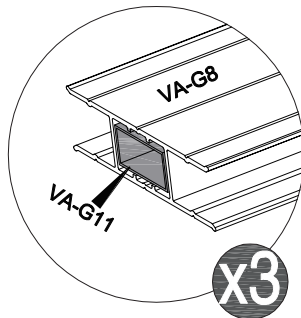
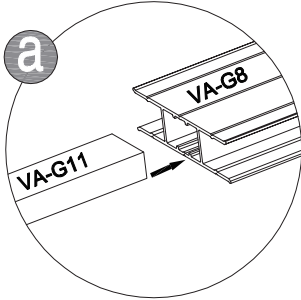

8	 VA-G8 [x3] 562mm	 VA-G11 [x3] 562mm		
----------	--	---	--	--

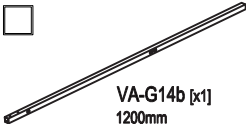

9	 VA-G14b [x1] 1200mm	 VA-G14c [x1] 1052mm	 VA-T46 [x9] 13mm			
----------	---	---	--	--	--	--

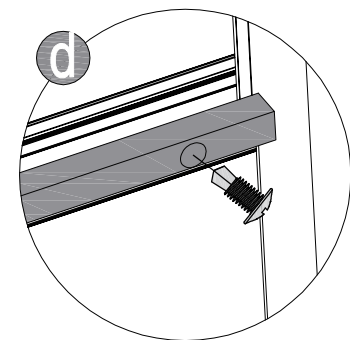
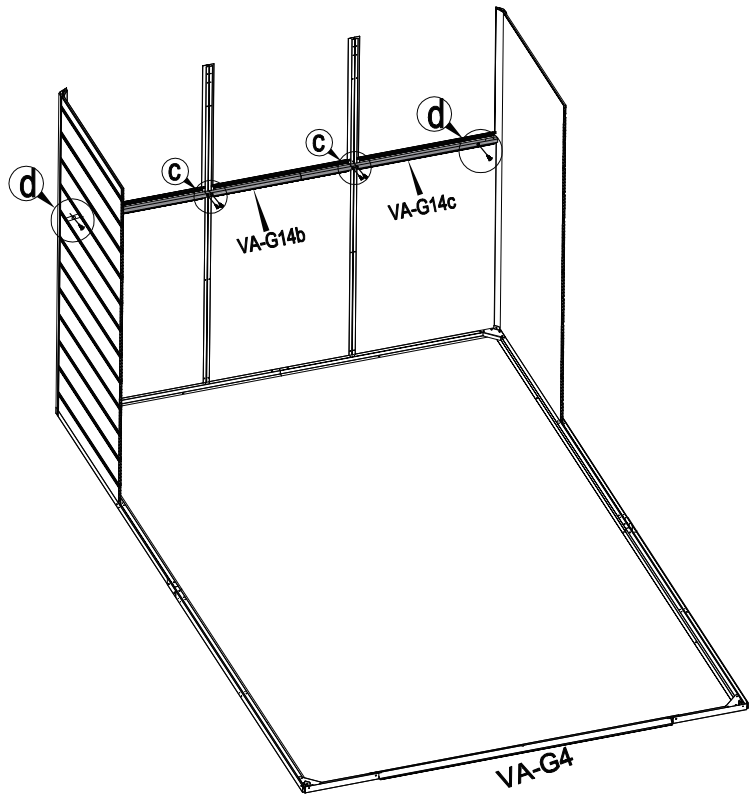
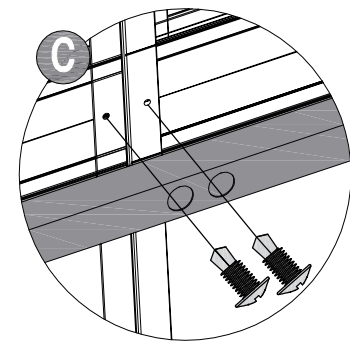
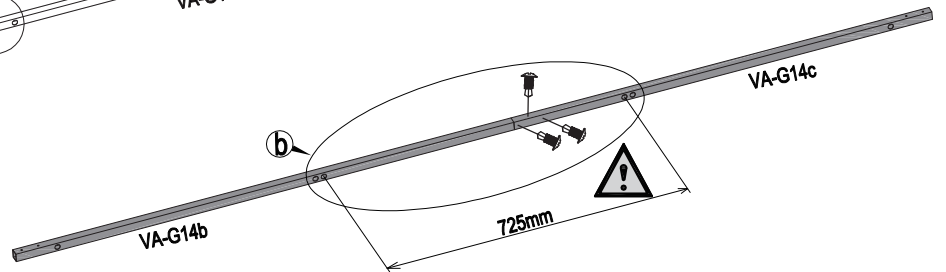
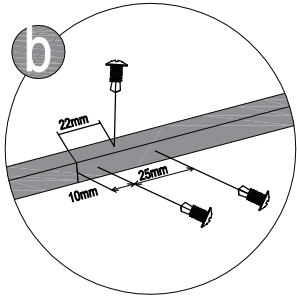
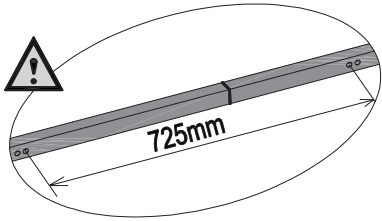
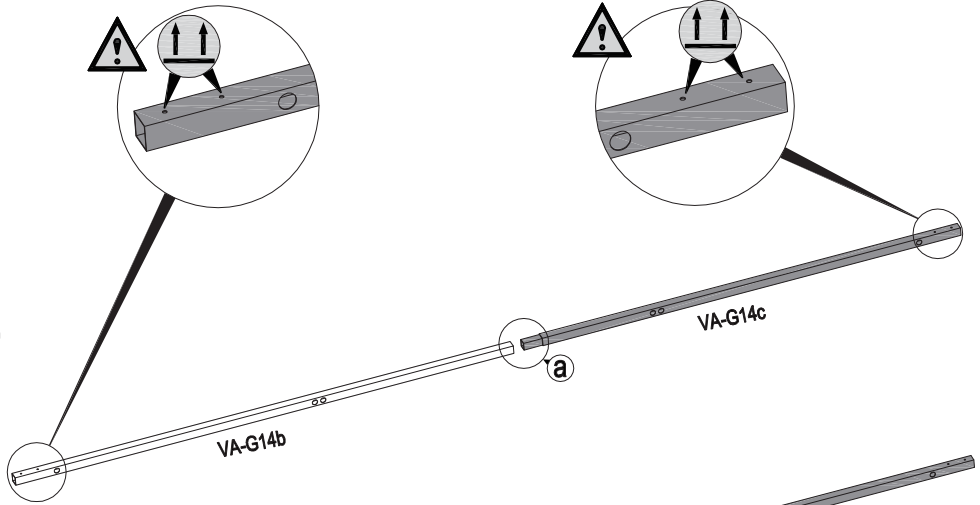
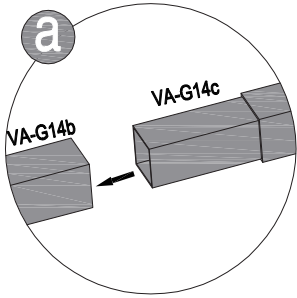

10		VA-C7L [x1]		PB1 [x1]		PC5 [x1]		VA-T45 [x11]	19mm		CN-A33	
		1860mm										

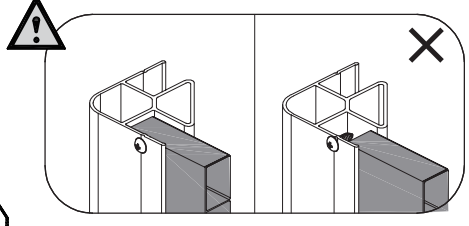
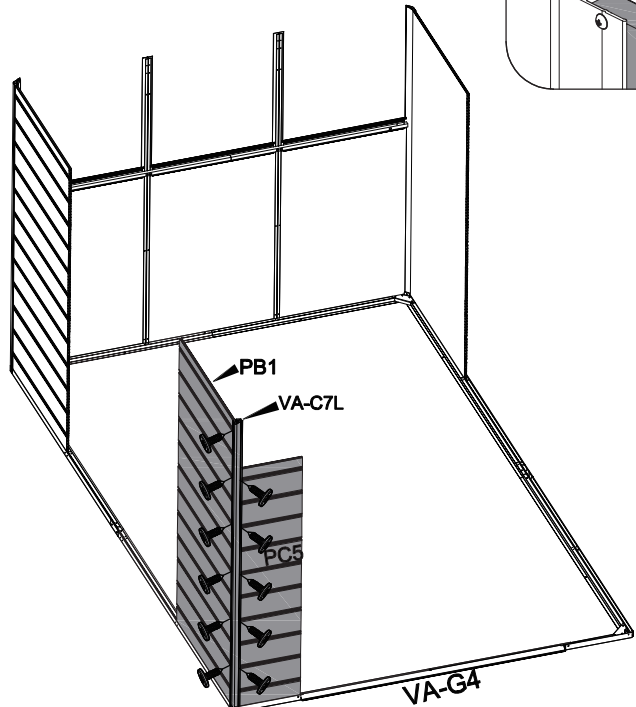
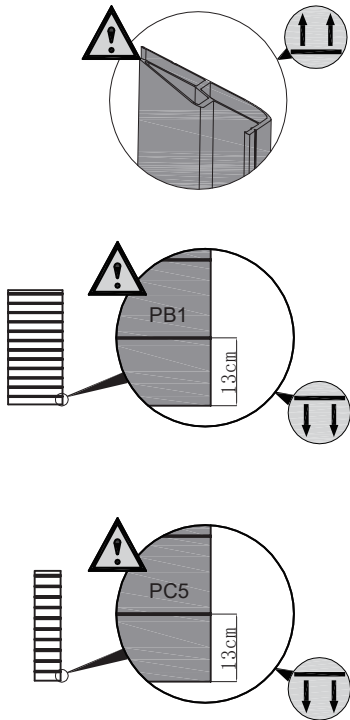

11		VA-C7R [x1]		PB1 [x1]		PC5 [x1]		VA-T45 [x11]	19mm		CN-A33	
		1860mm										

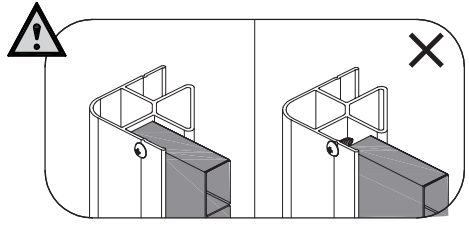
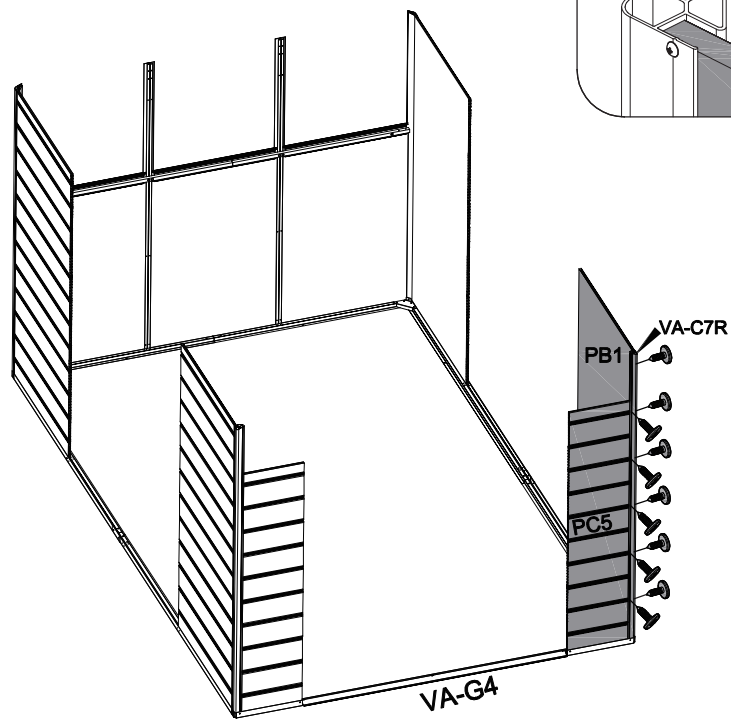
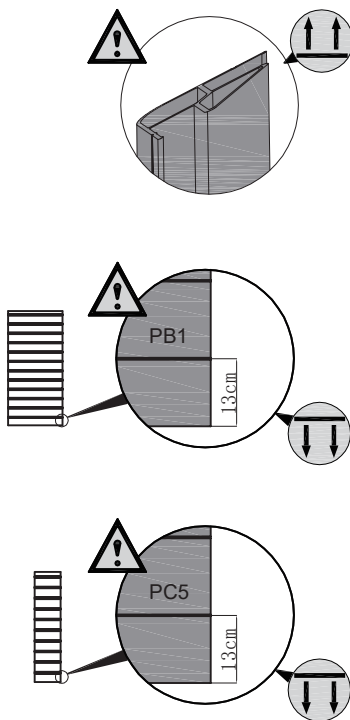

12



VA-31 [x4]



VA-T44 [x8]
13mm

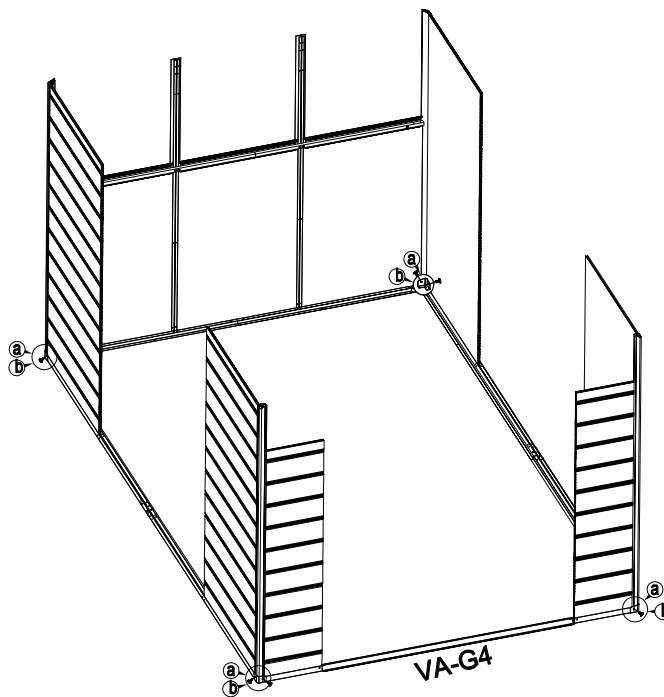
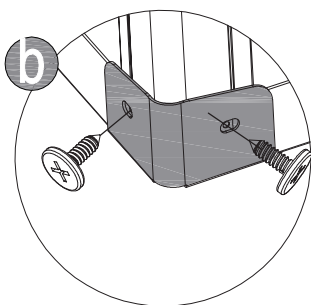
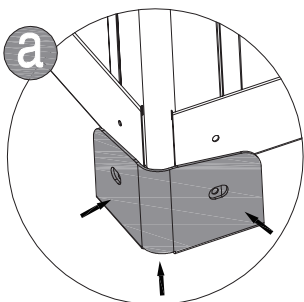



13

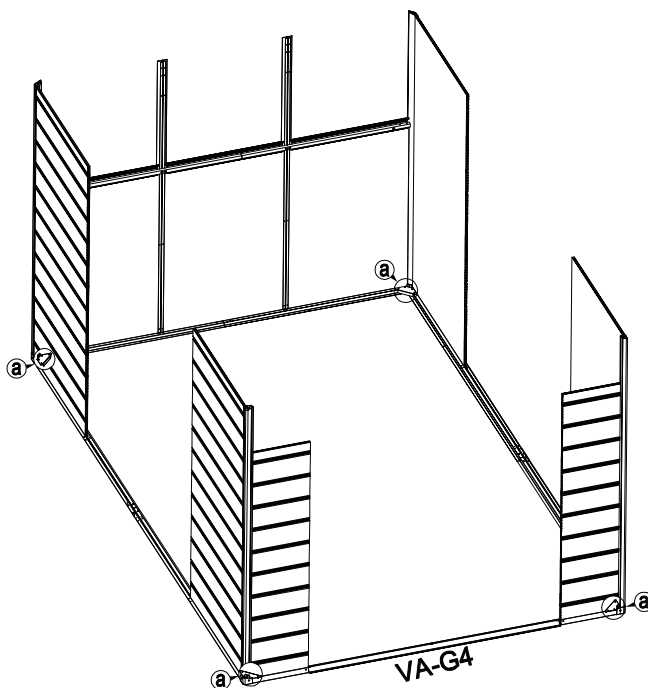
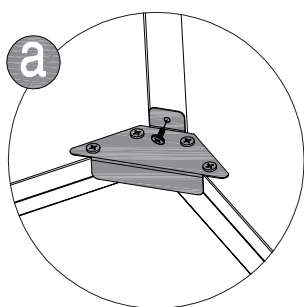

VA-T44 [x4]
13mm

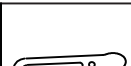

14	 VA-C5 [x4] 1840mm	 VA-T44 [x4] 13mm	 CN-A33	
----	---	--	---	--

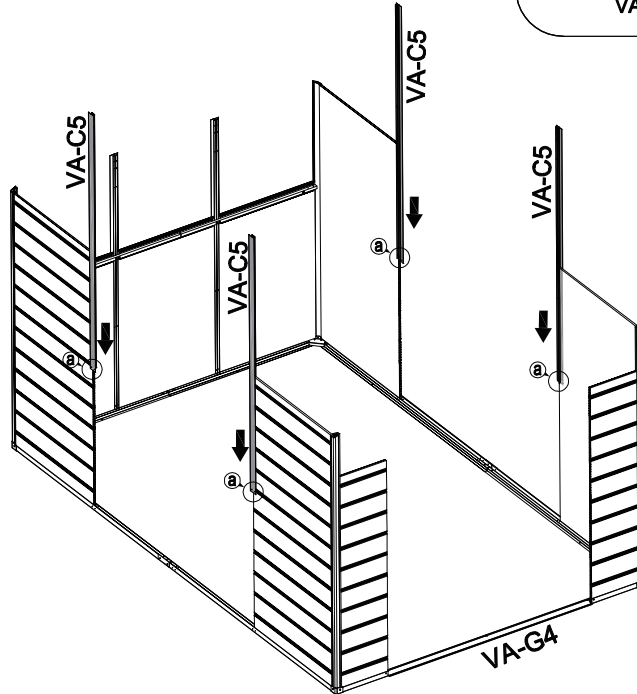
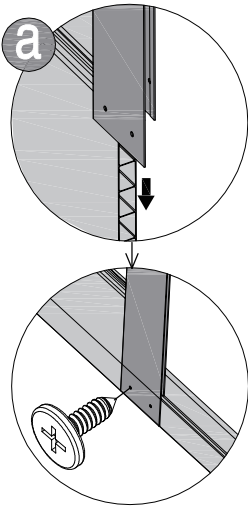
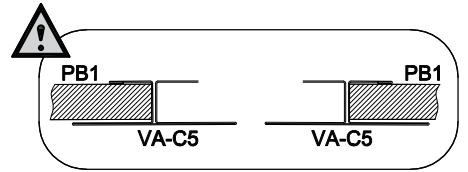
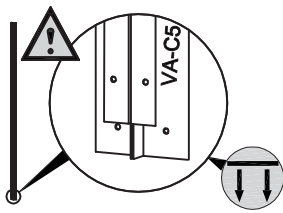

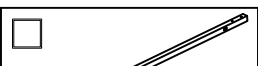
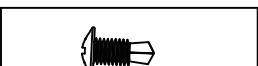
15	 VA-F16 [x2] 1678mm	 VA-F15 [x2] 1850mm	 VA-T46 [x6] 13mm			
----	--	--	--	--	--	--

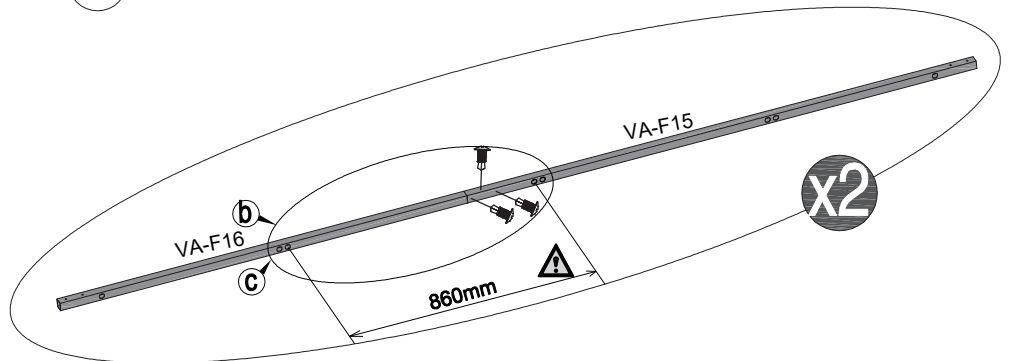
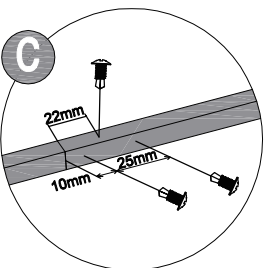
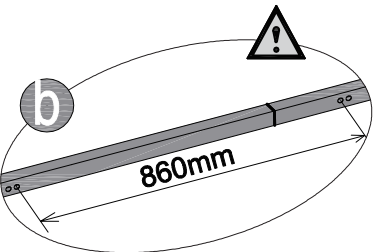
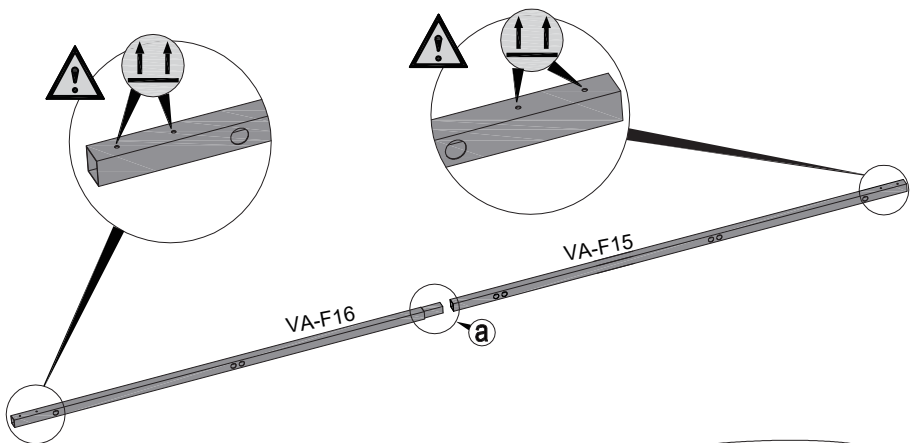
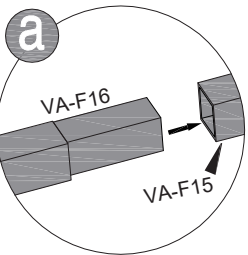

16



VA-30 [x2]







VA-T44 [x10]
13mm

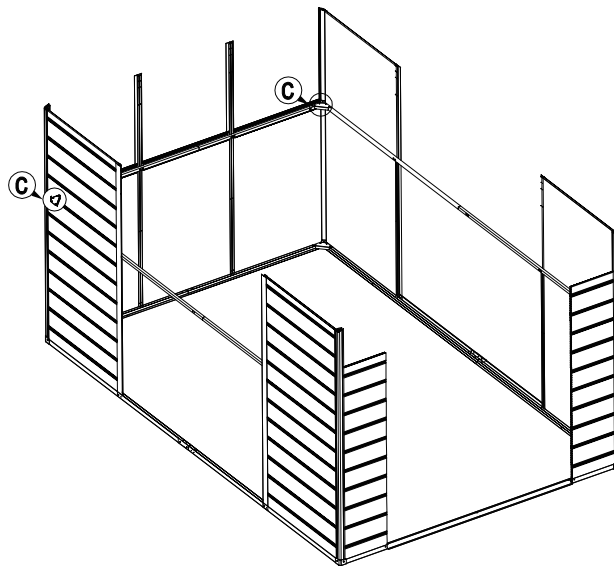
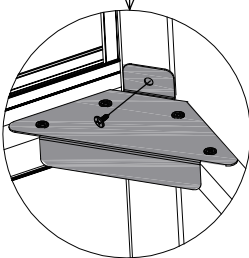
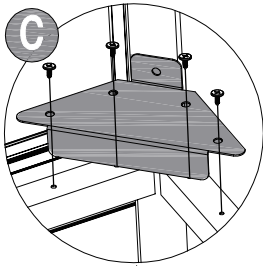
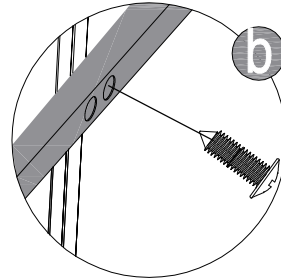
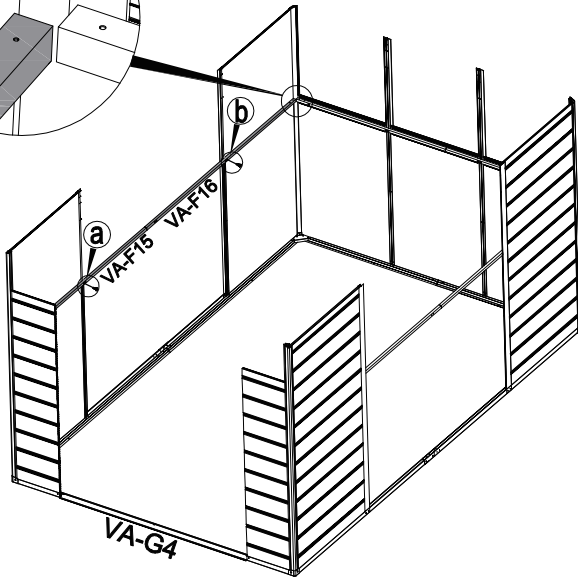
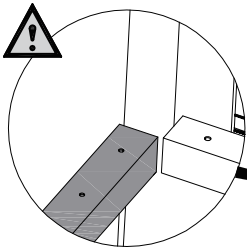
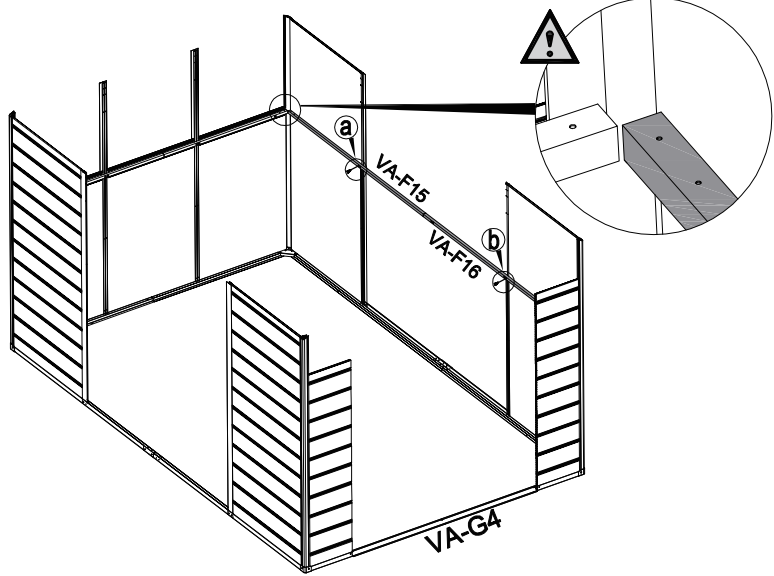
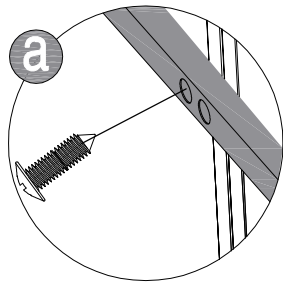





VA-T49 [x4]
13mm

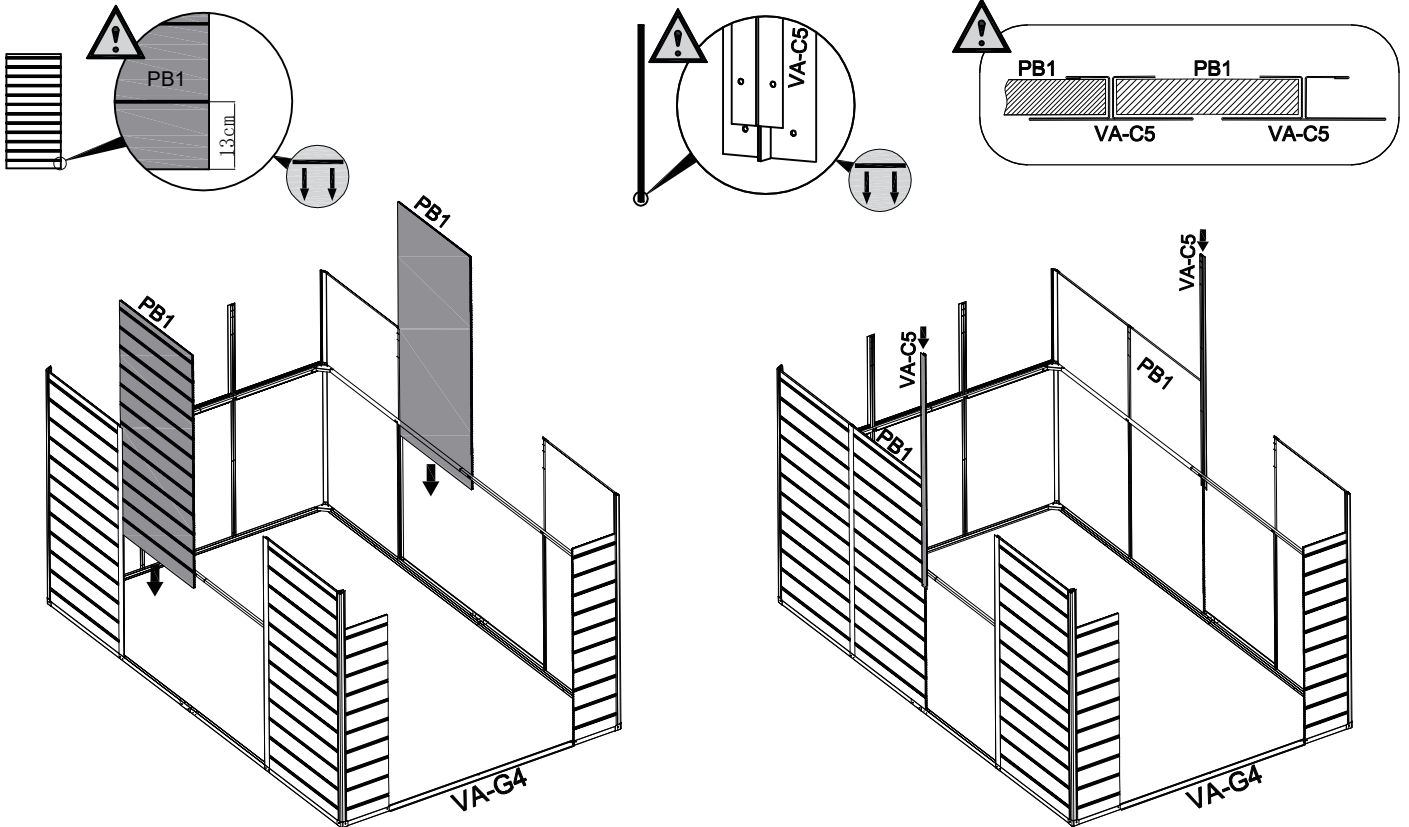

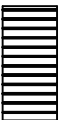
17	 PB1 [x2] 876x1840mm	 VA-C5 [x2] 1840mm	 CN-A33	
-----------	---	---	---	---



18	 PB1 [x1] 876x1840mm	 PB1S [x1] 876x1840mm	 VA-T44 [x12] 13mm	 CN-A33	
-----------	---	--	---	--	---

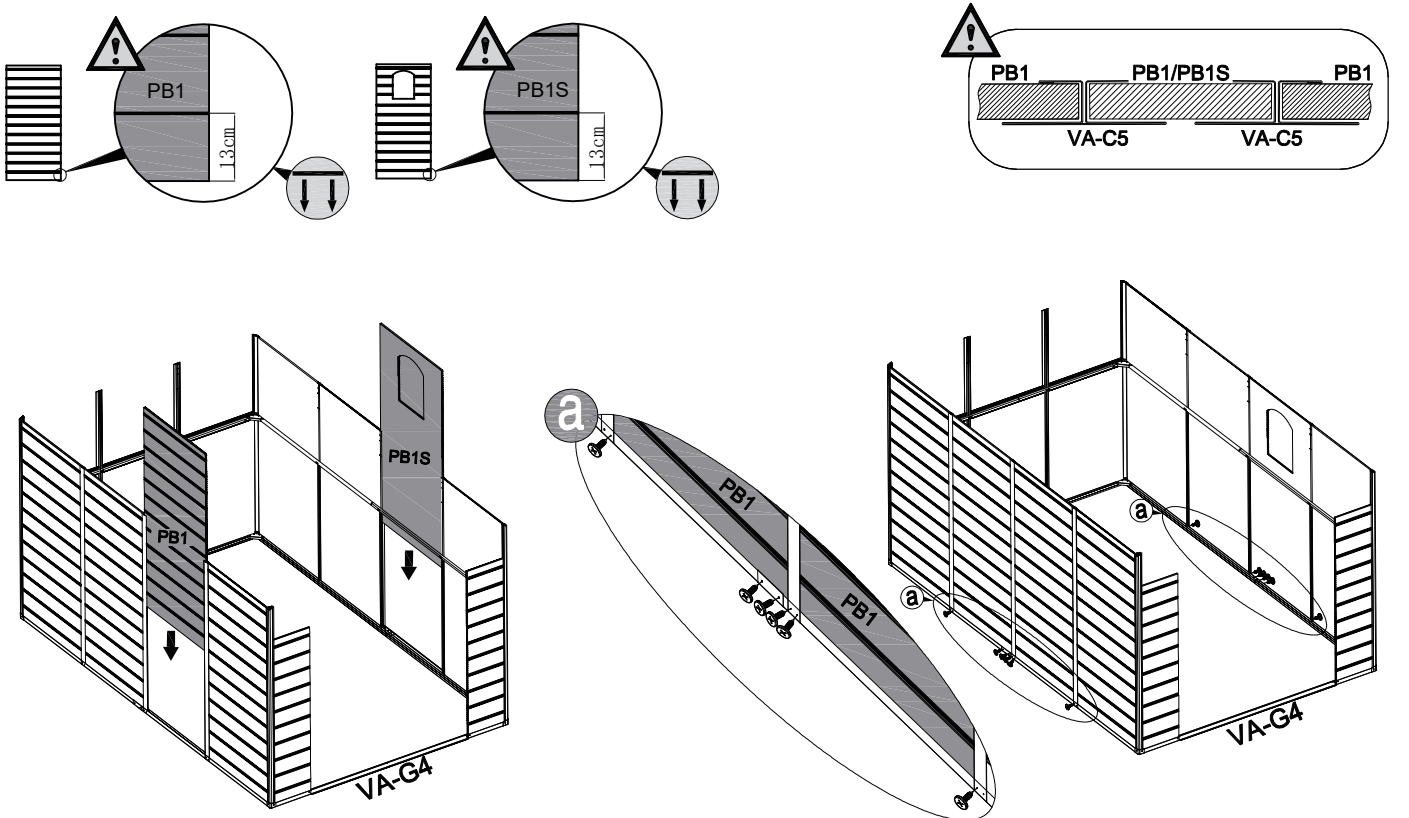

19



VA-T49 [x8]
13mm

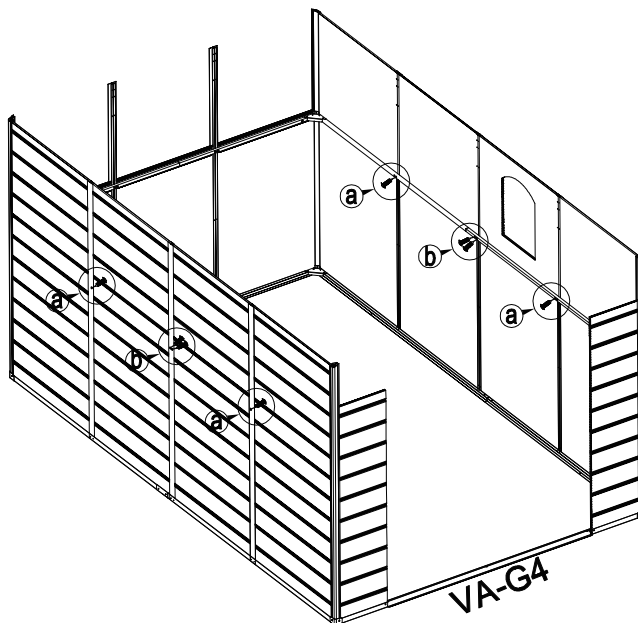
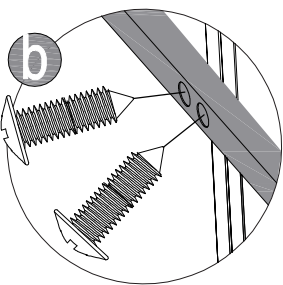
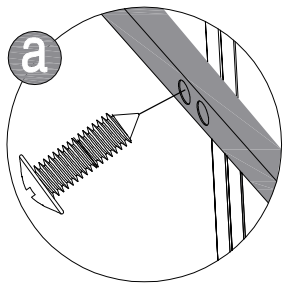

VA-G4

20

PC3L [x1]
743x1072mm



PC3R [x1]
743x1072mm



PC3S [x1]
743x1248mm



VA-T45 [x6]
19mm



CN-A33

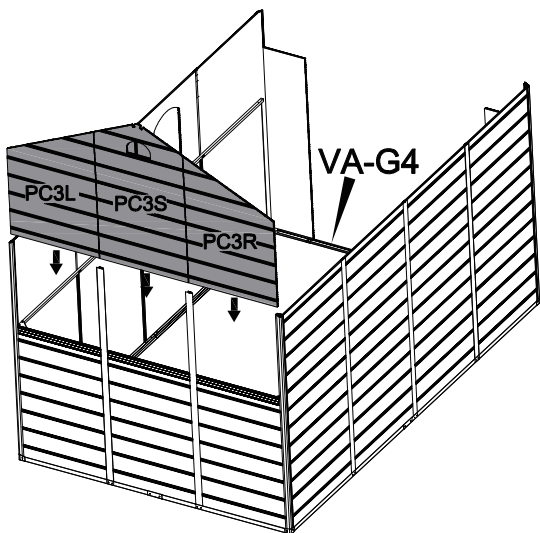
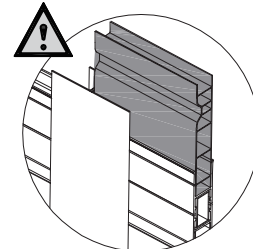
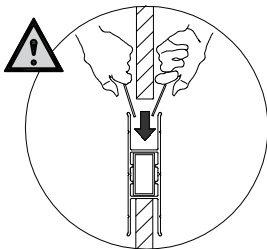
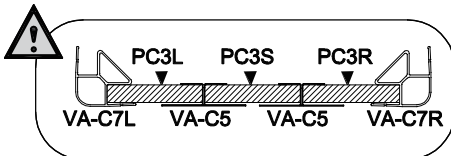

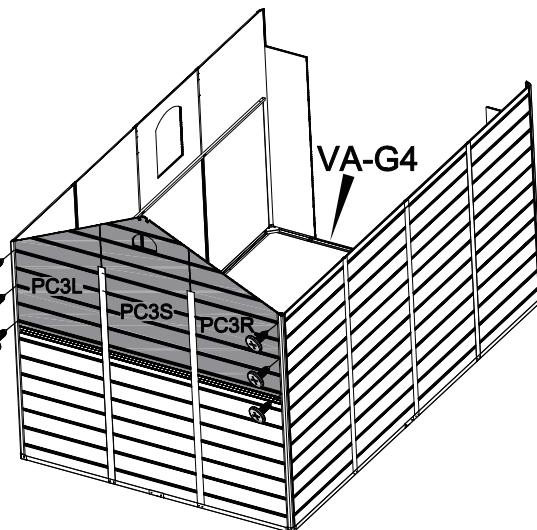

VA-G4



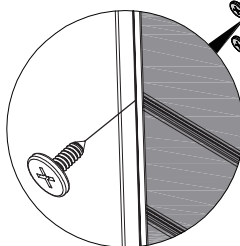

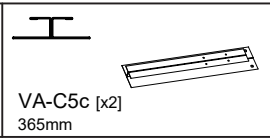
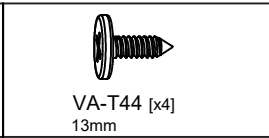
VA-G4

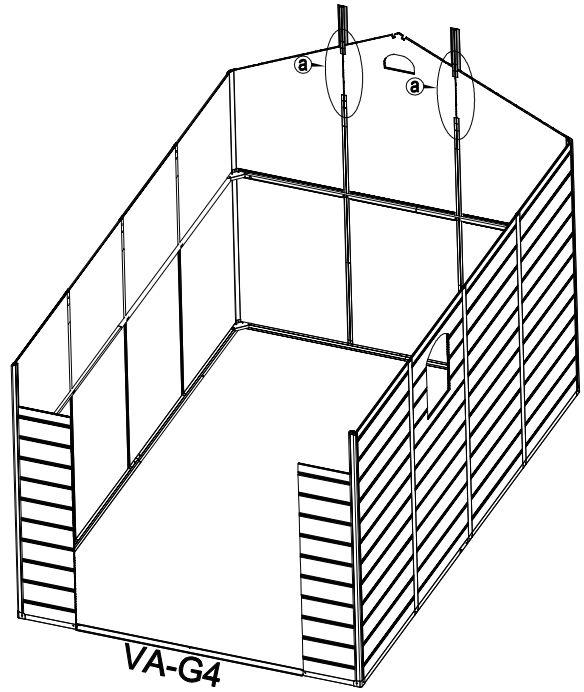
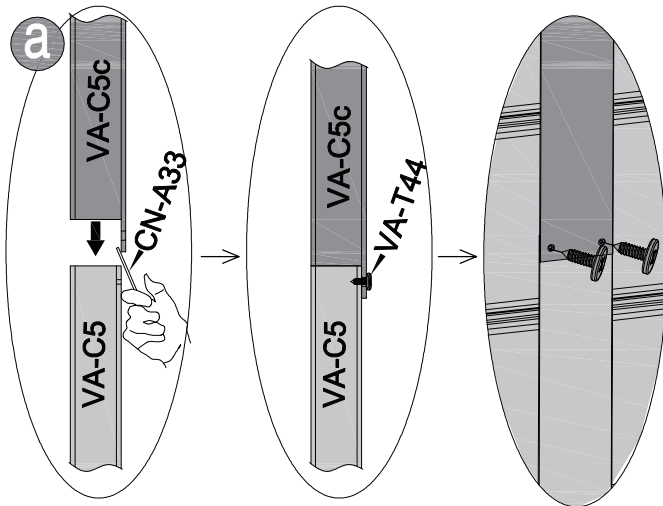
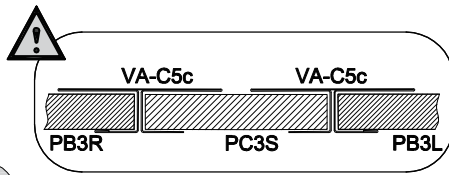
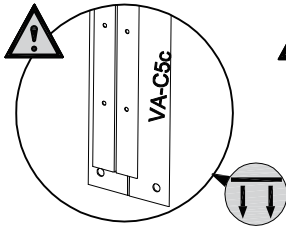

<p>21</p>	 <p>VA-C5c [x2] 365mm</p>	 <p>VA-T44 [x4] 13mm</p>	 <p>CN-A33</p>
------------------	--	---	--

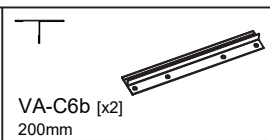



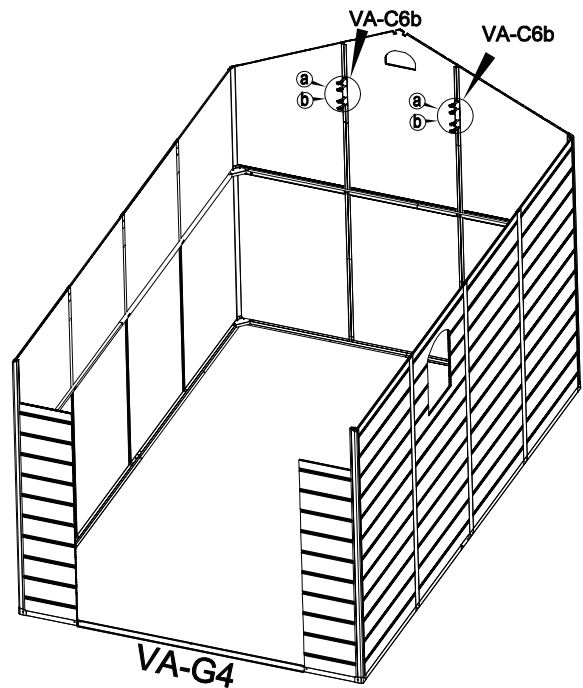
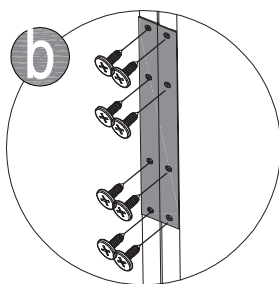
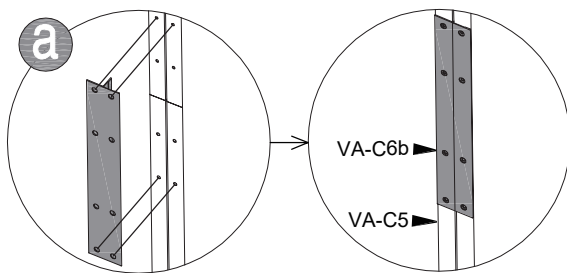

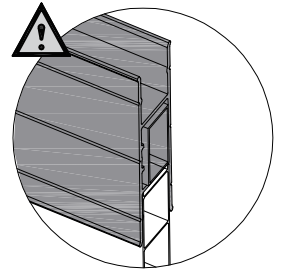
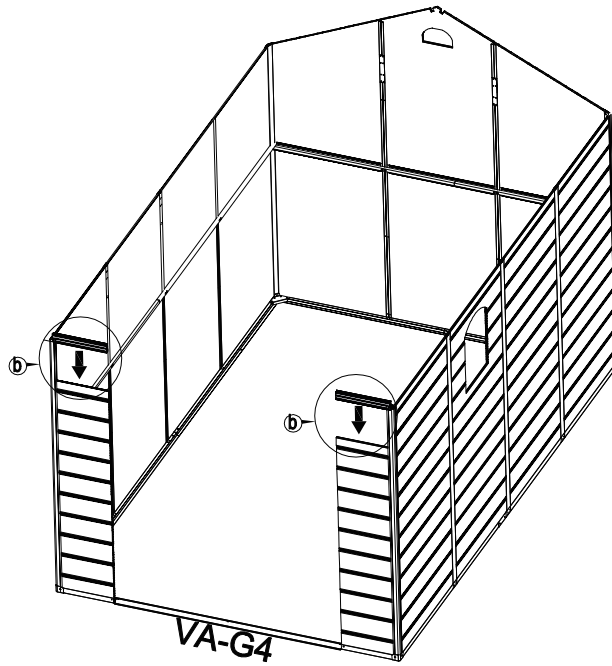
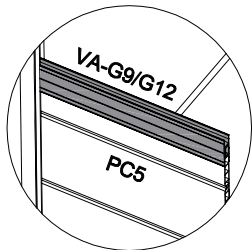
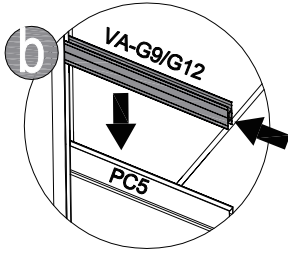
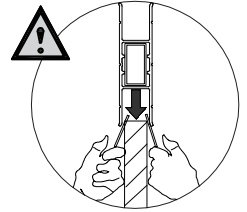
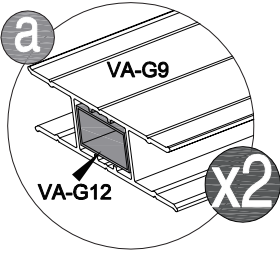

<p>22</p>	 <p>VA-C6b [x2] 200mm</p>	 <p>VA-T44 [x16] 13mm</p>	
------------------	--	--	--



23				
	VA-G9 [x2] 360m	VA-G12 [x2] 360mm		



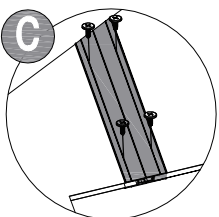
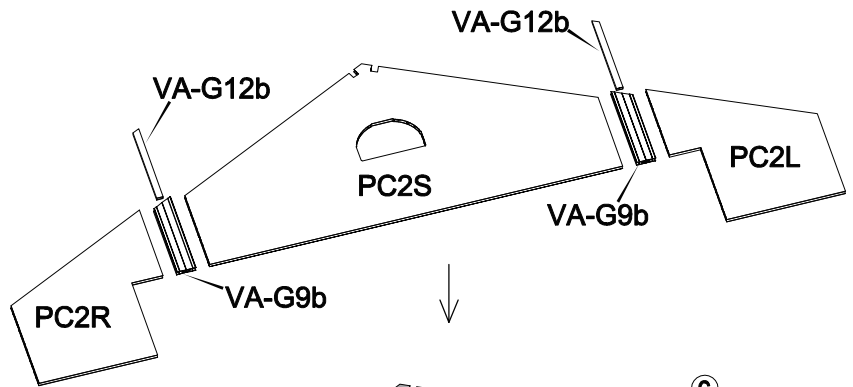
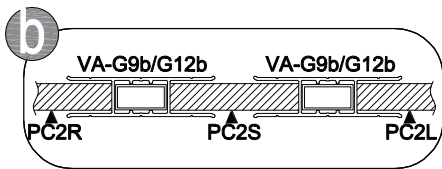
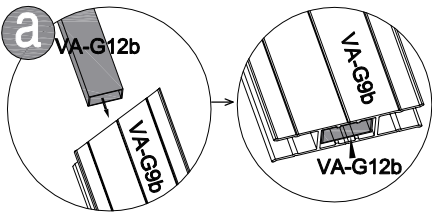

24						
	PC2S [x1] 1270x542mm	PC2L [x1] 461x492mm	PC2R [x1] 461x492mm	VA-G9b [x2] 254mm	VA-G12b [x2] 225mm	

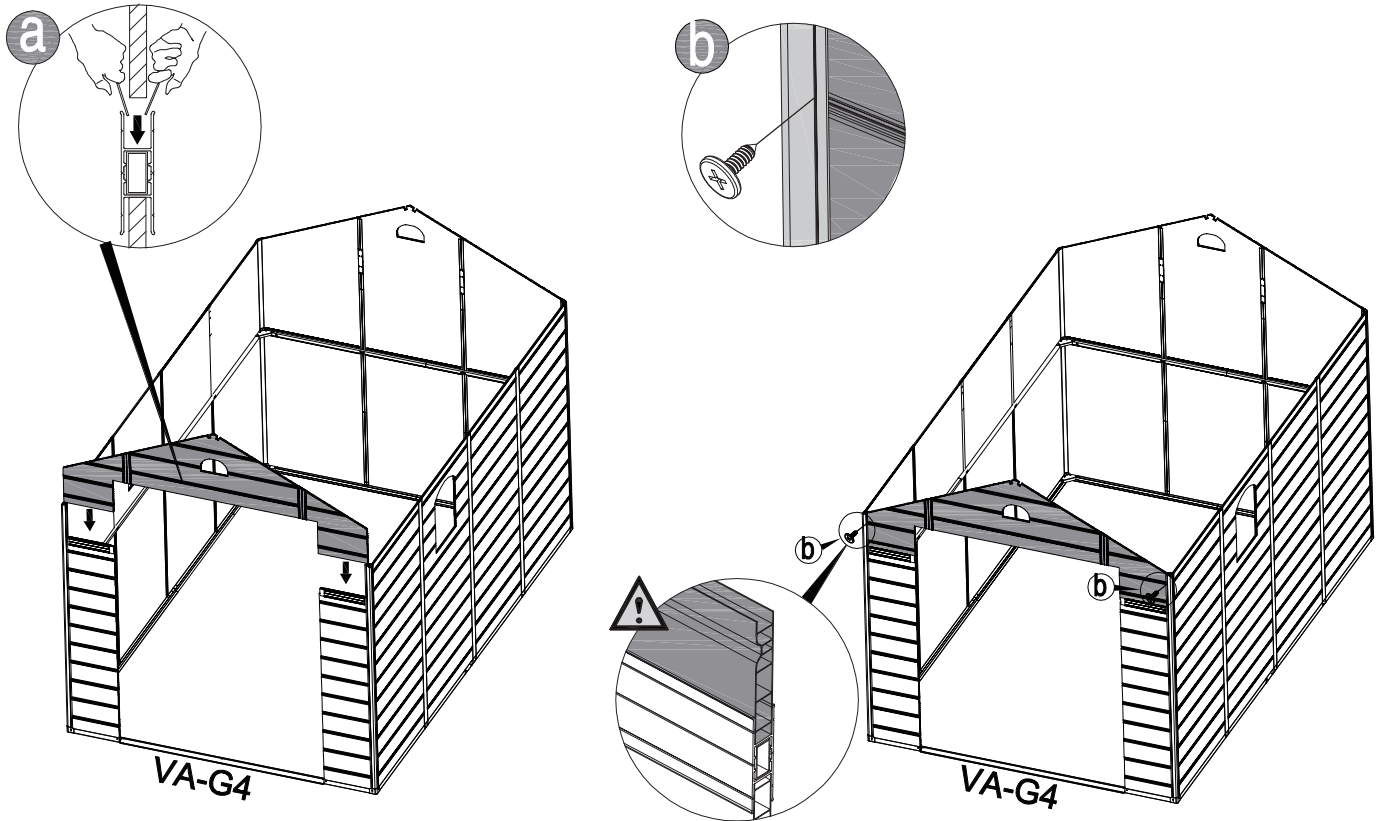

25	 VA-T45 [x2] 19mm		 CN-A33		
----	--	--	---	---	---

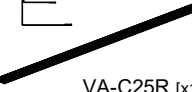



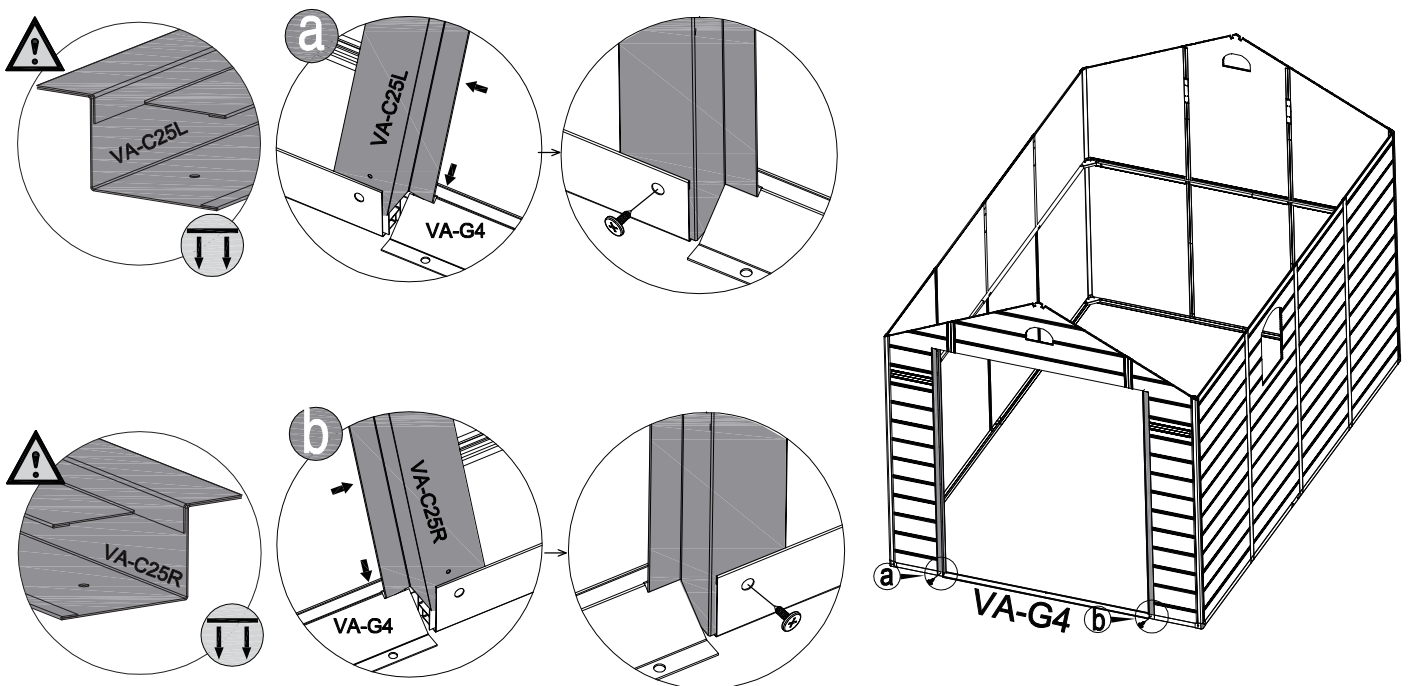

26	 VA-C25L [x1] 1830mm	 VA-C25R [x1] 1830mm	 VA-T44 [x2] 13mm	
----	---	---	--	--

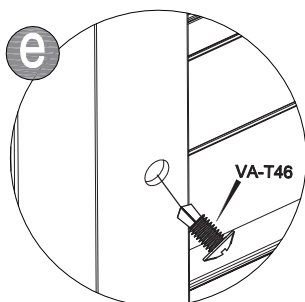
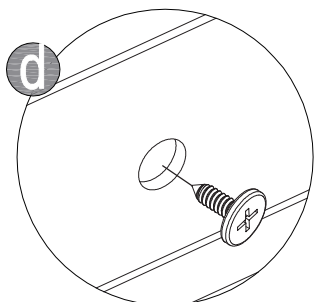
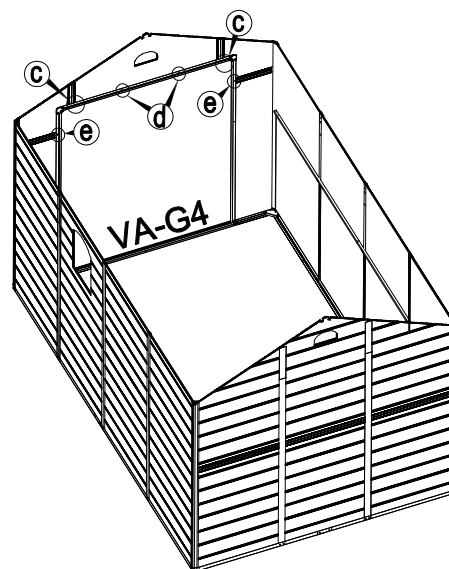
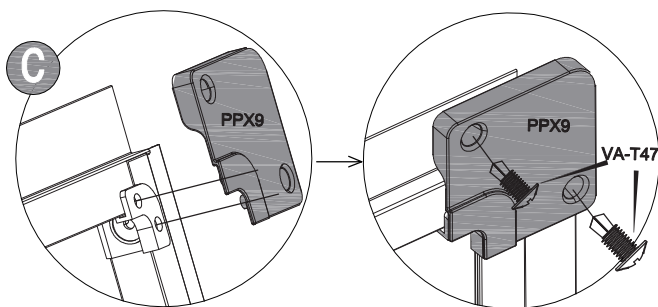
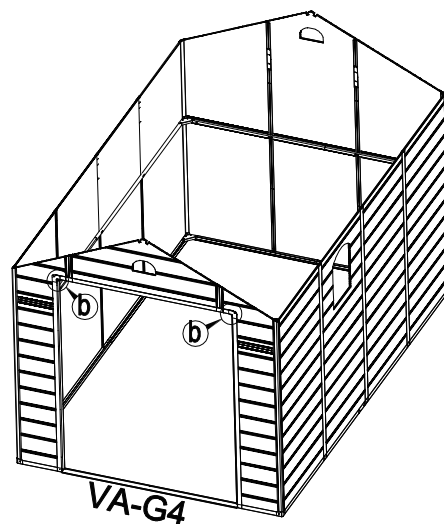
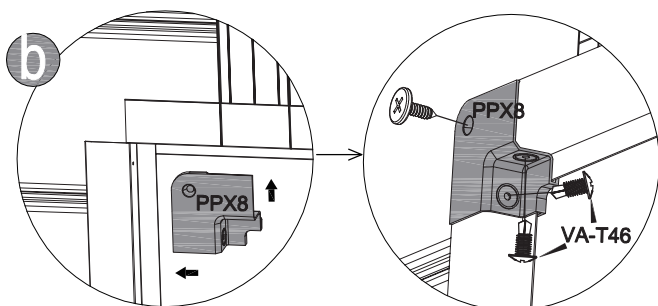
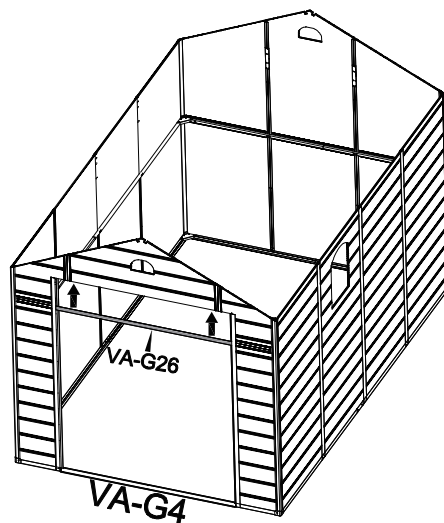
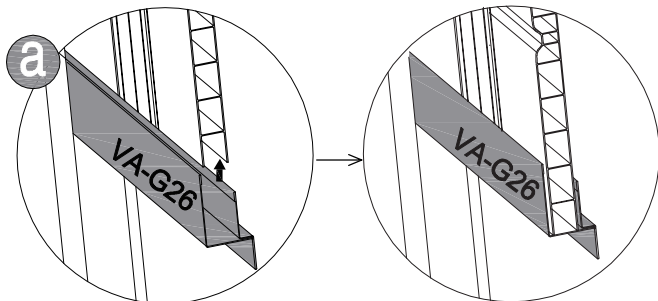
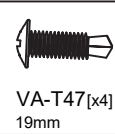
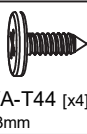
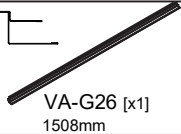



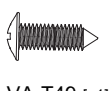

27

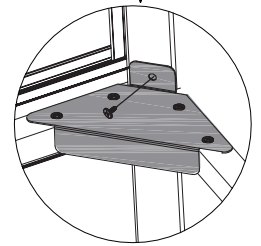
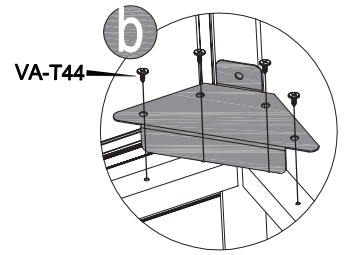
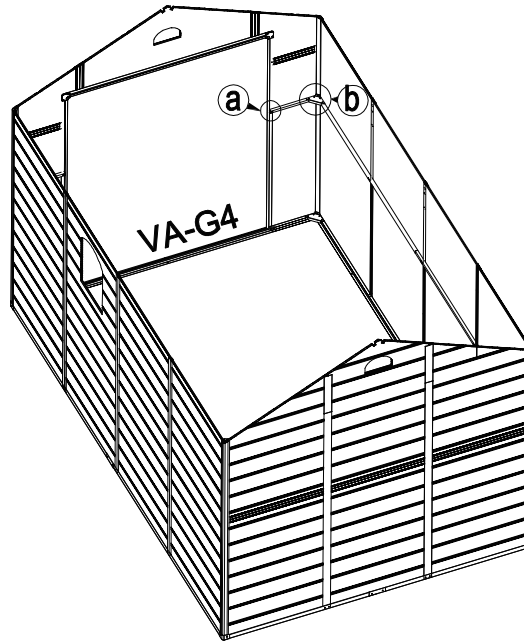
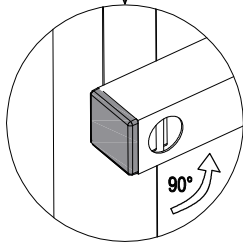
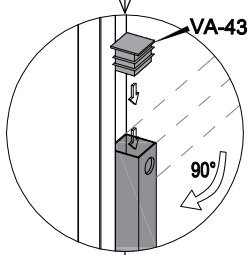
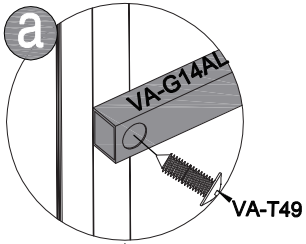

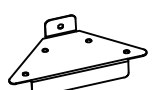
28	 VA-G14AL [x1] 345mm	 VA-30 [x1]	 VA-43 [x1]	 VA-T49 [x1] 13mm	 VA-T44 [x5] 13mm		
----	---	---	---	--	--	--	--

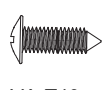

29	 VA-G14AR [x1] 345mm	 VA-30 [x1]	 VA-43 [x1]	 VA-T49 [x1] 13mm	 VA-T44 [x5] 13mm		
----	---	---	---	--	--	--	--

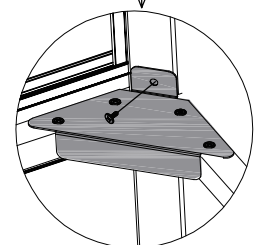
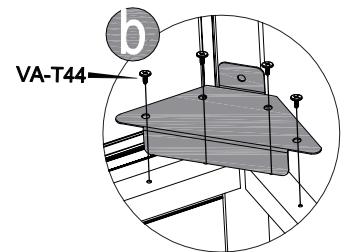
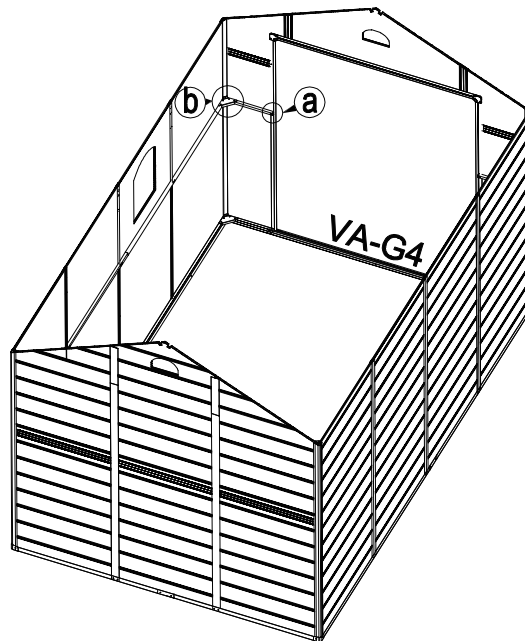
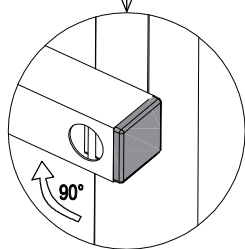
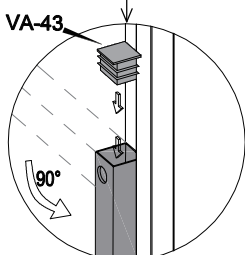
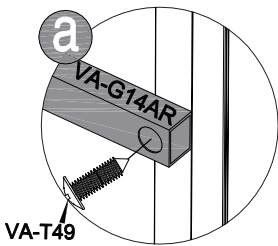





30

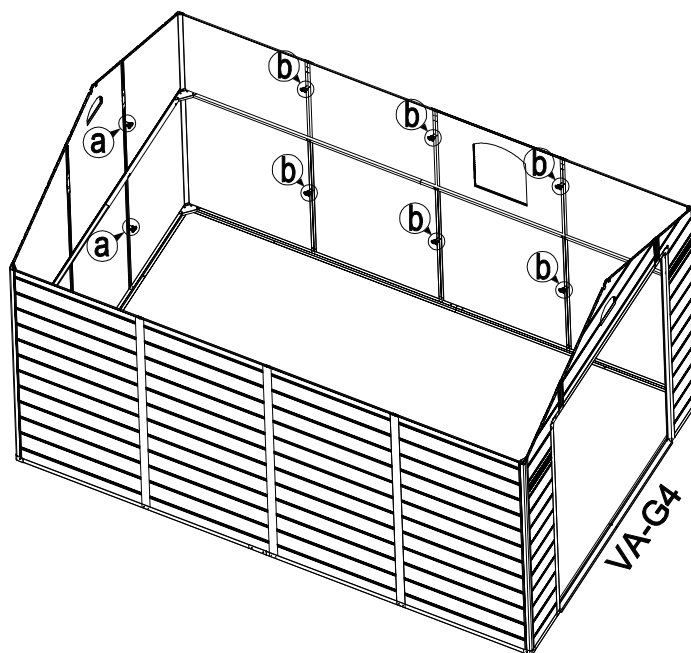
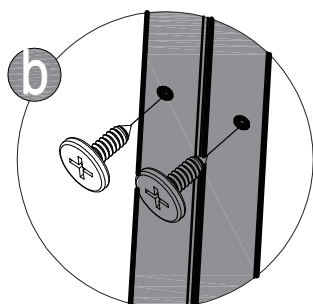
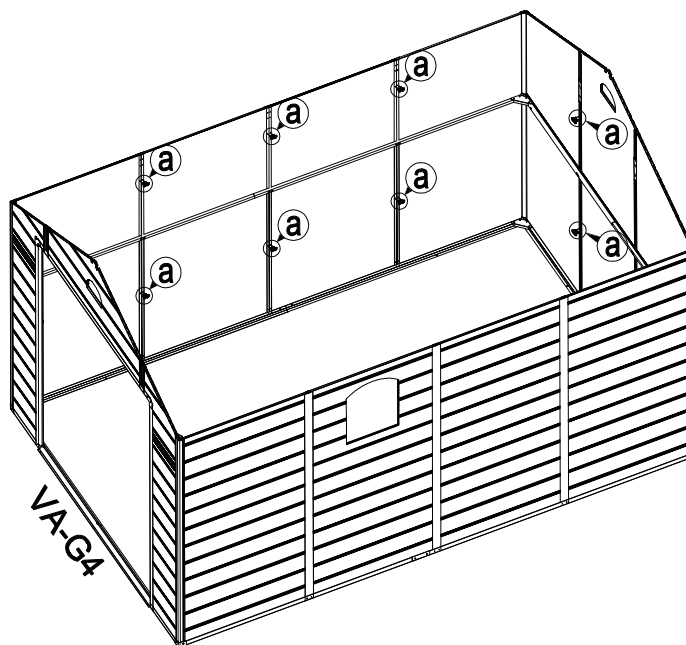
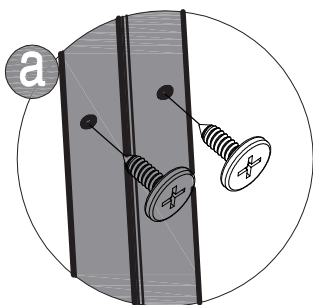

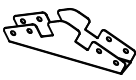

VA-T44 [x32]
13mm

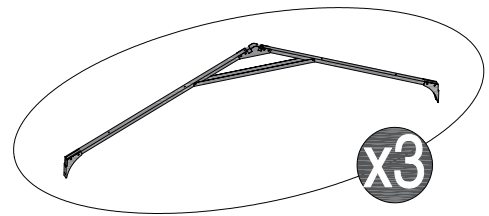
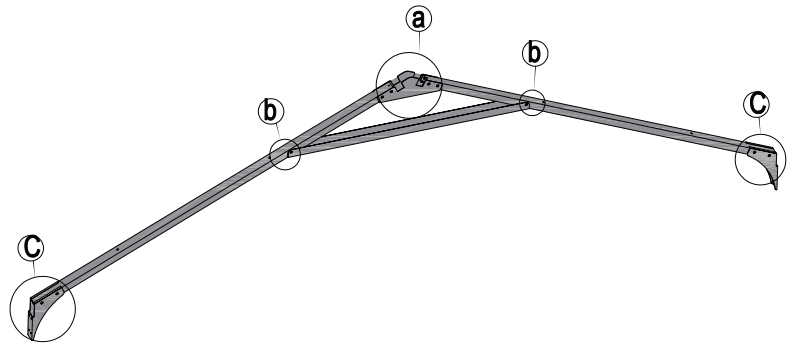
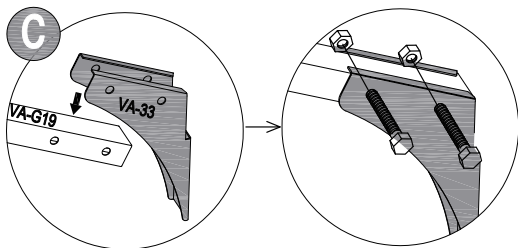
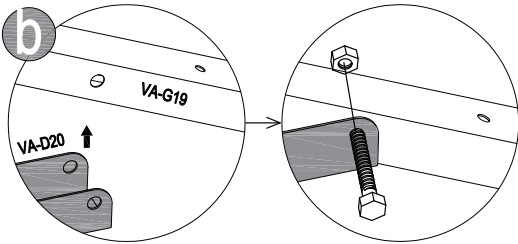
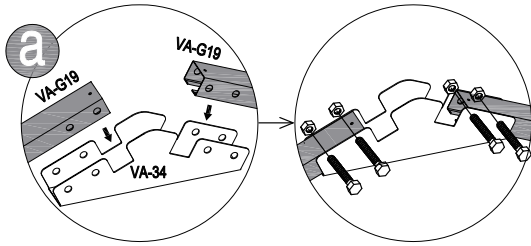

31	 VA-34 [x3]	 VA-33 [x6]	 VA-G19 [x6] 1181mm	 VA-D20 [x3] 725mm	 VA-T50 [x30] 40mm	
----	---	---	--	--	---	--



32	 VA-F17 [x2] 1857mm	 VA-E18 [x2] 1745mm	 VA-T46 [x6] 13mm	
----	--	--	--	--

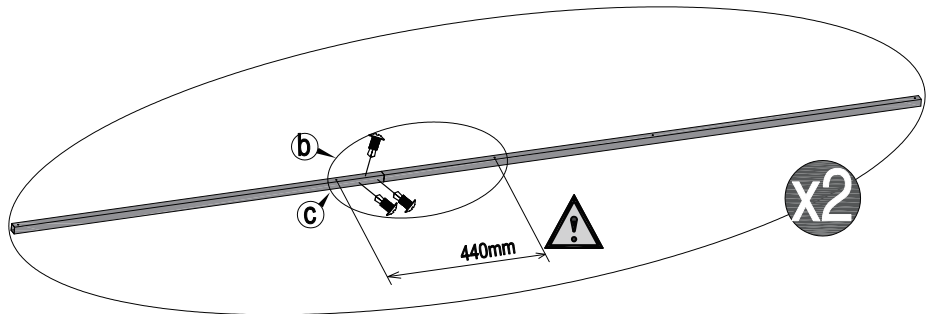
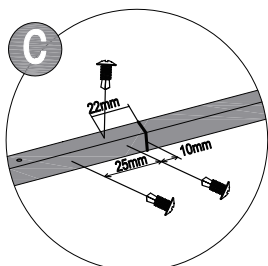
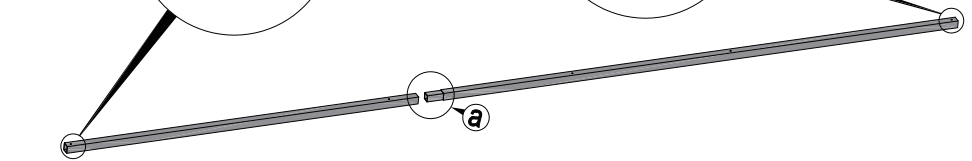
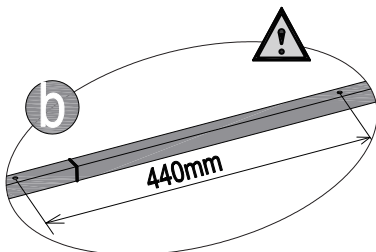
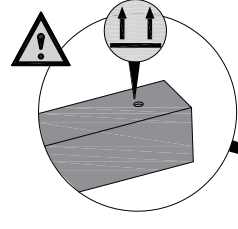
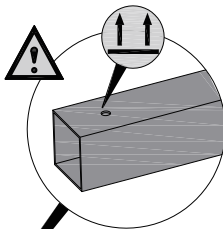
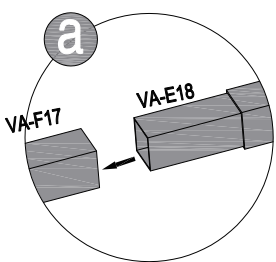

33

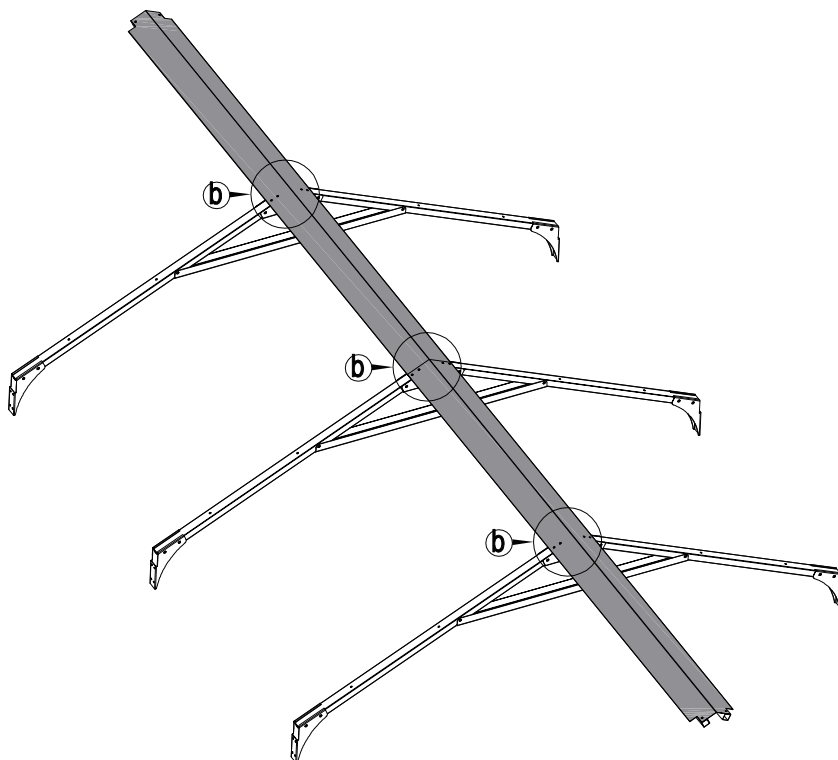
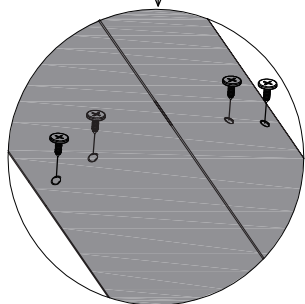
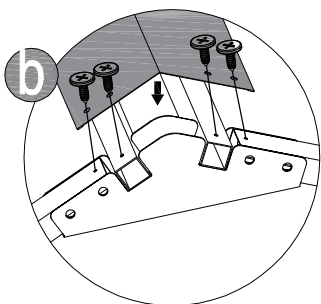
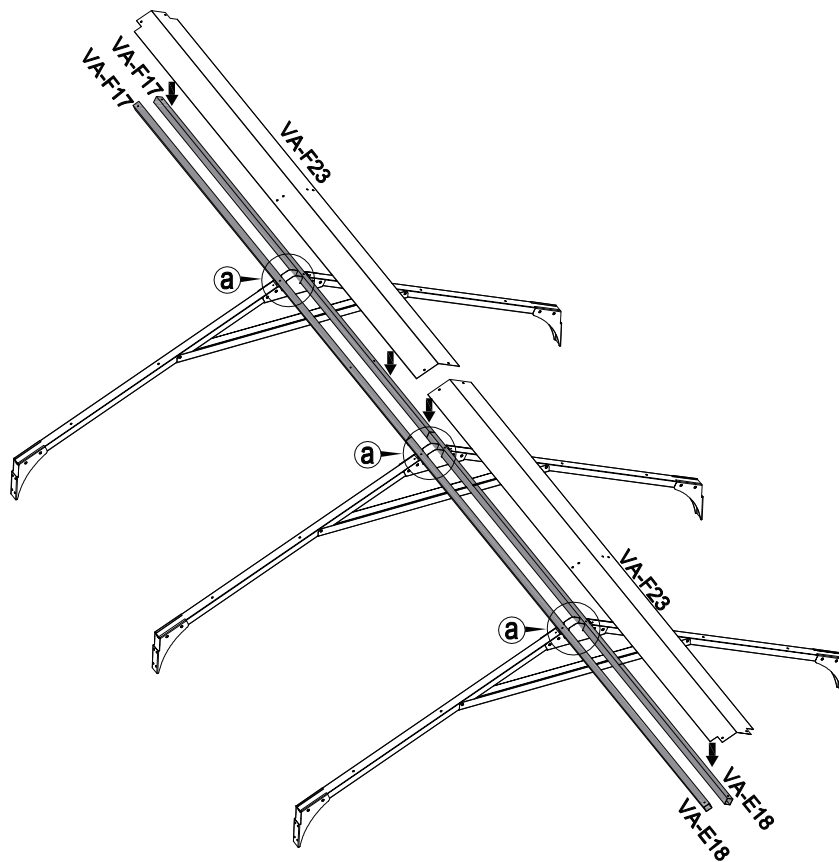
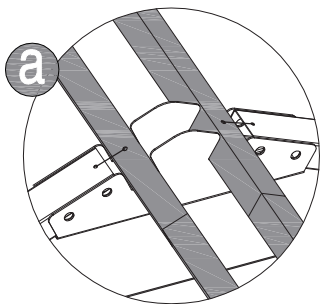
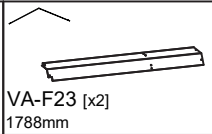

34







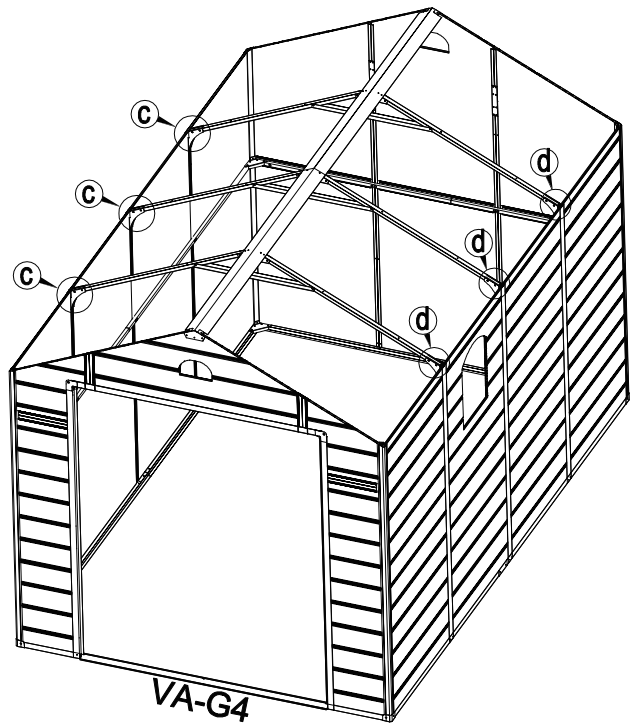
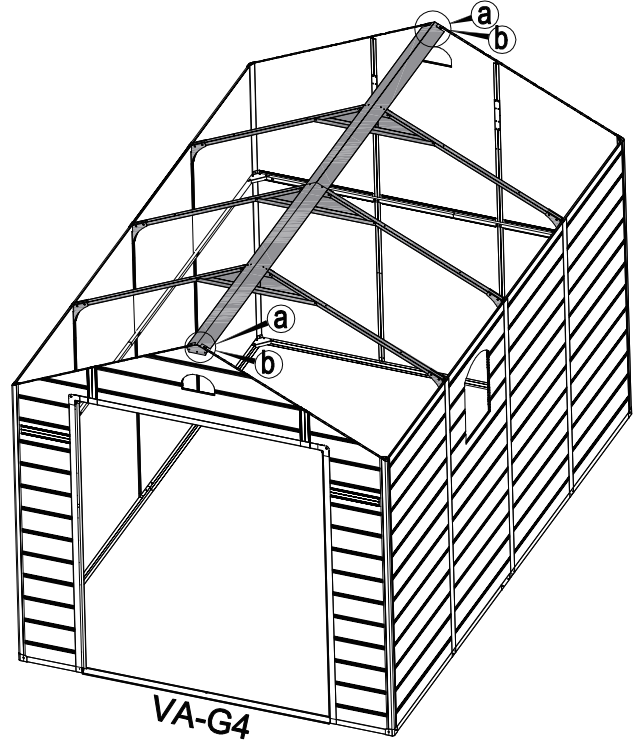
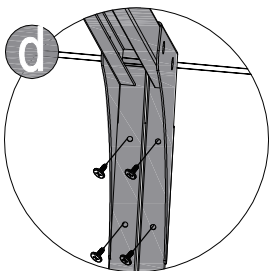
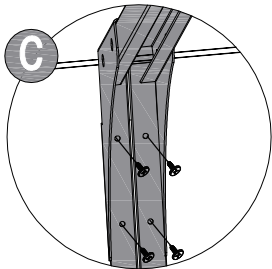
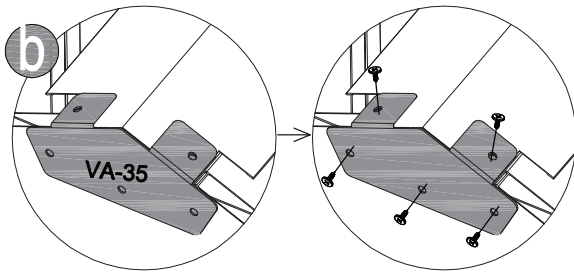
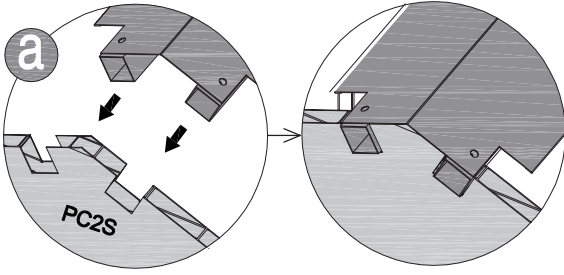

VA-35 [x2]

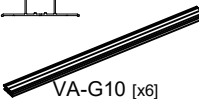

VA-T44 [x34]
13mm



35	 PC6-M [x4] 1285x856mm	 PC6-C [x4] 1285x920mm	 VA-G10 [x6] 1285mm	 VA-G13 [x6] 1285mm	 VA-T44 [x48] 13mm	 CN-A33
----	---	---	--	---	---	---

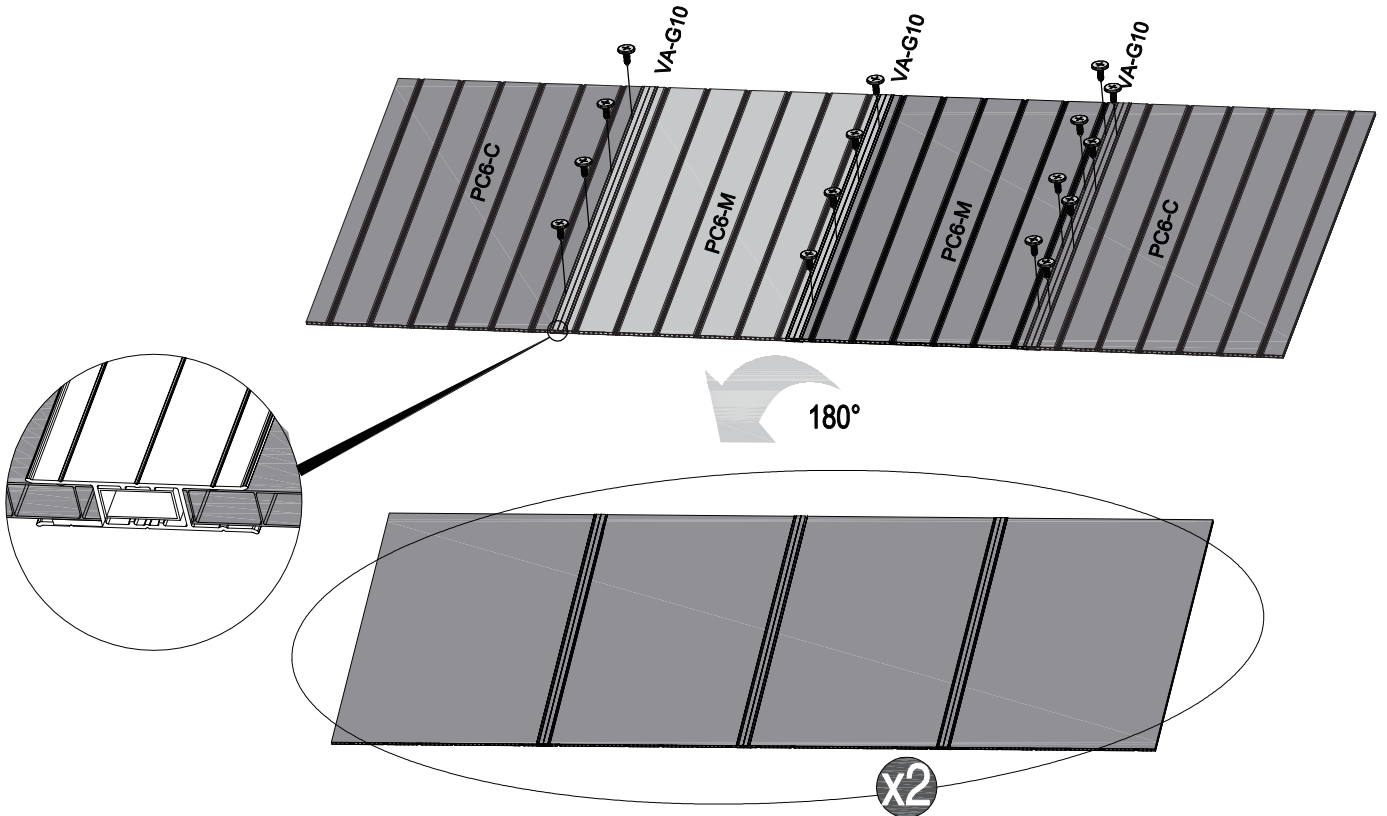
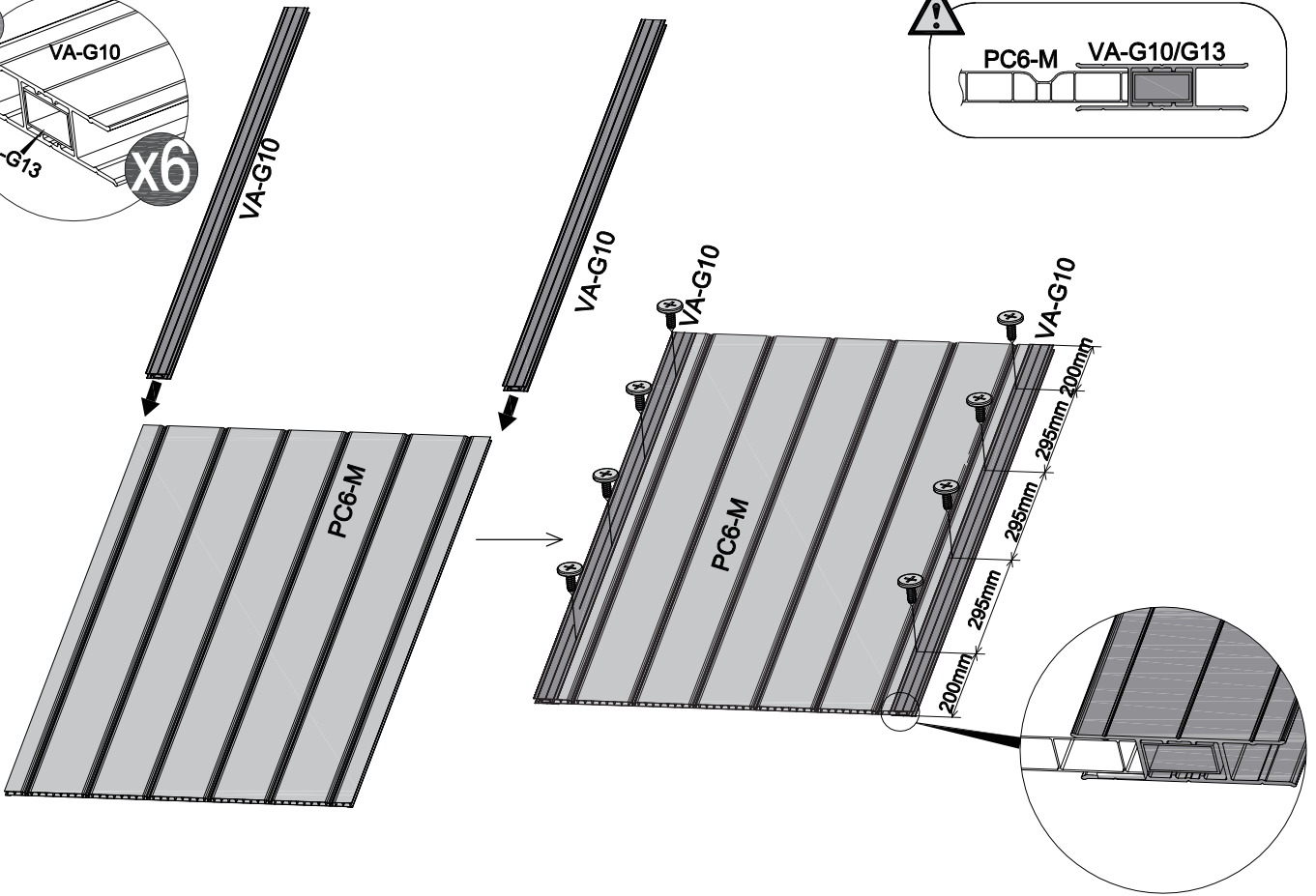
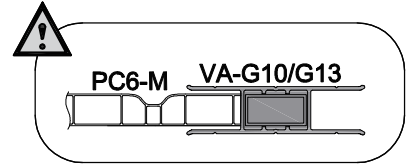
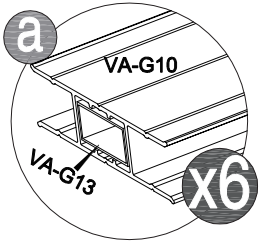

36	 VA-53 [x3]	 VA-T44 [x36] 13mm		 CN-A33
----	---	---	--	---

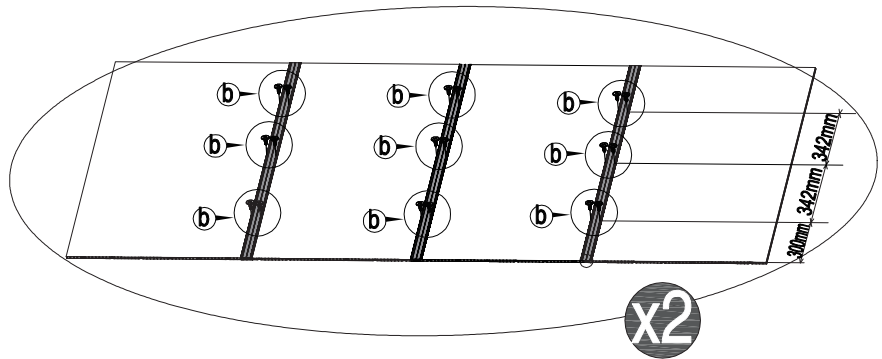
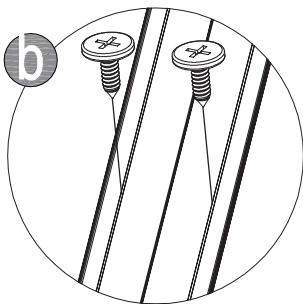
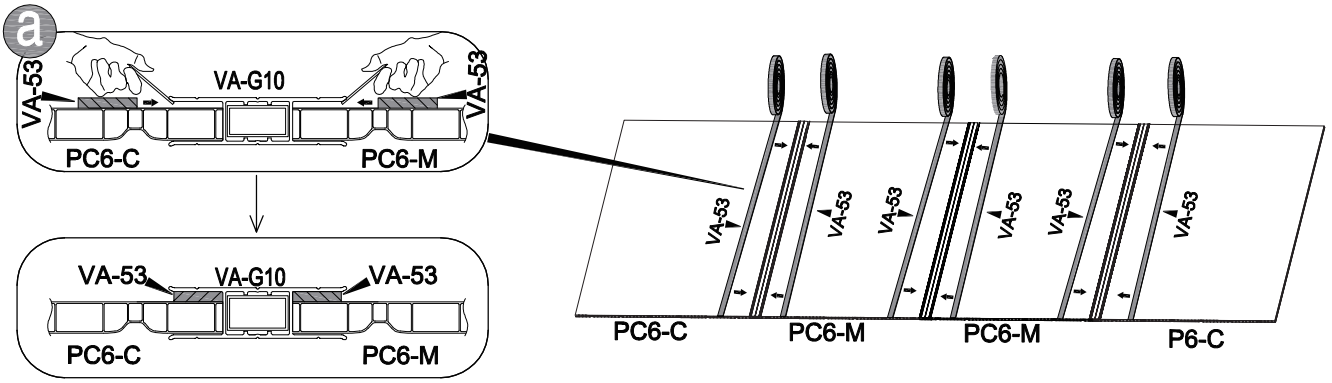

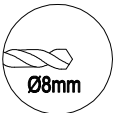
37	 VA-F22 [x4] 1722mm	 Ø8mm		
----	--	---	--	--

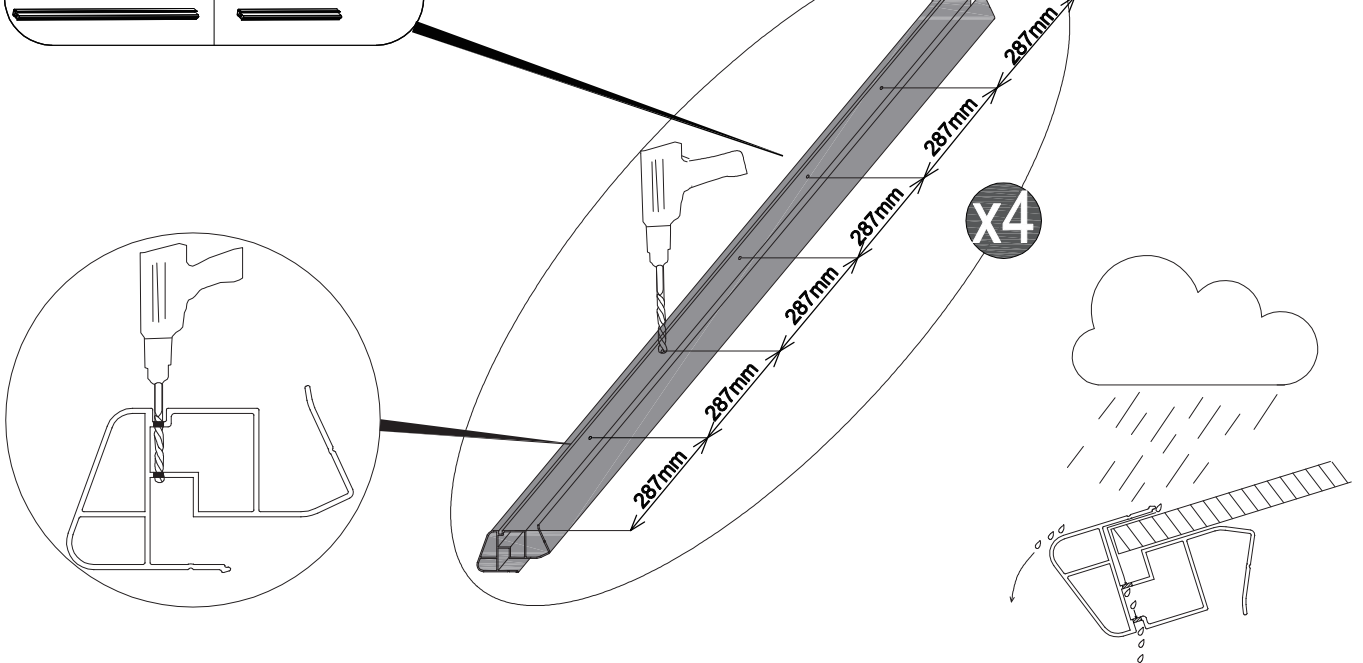
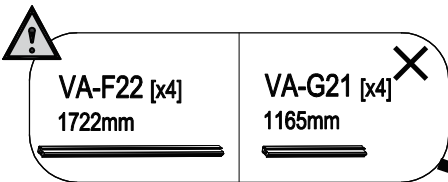

38



VA-F22 [x4]
1722mm



PPX11 [x2]





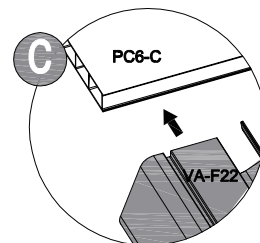
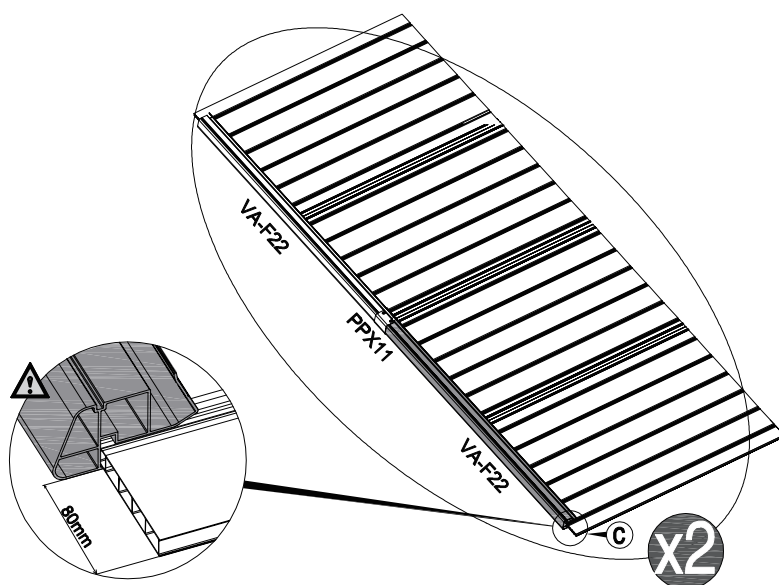
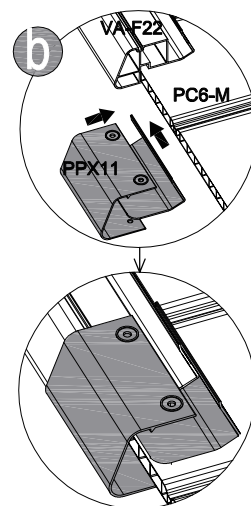
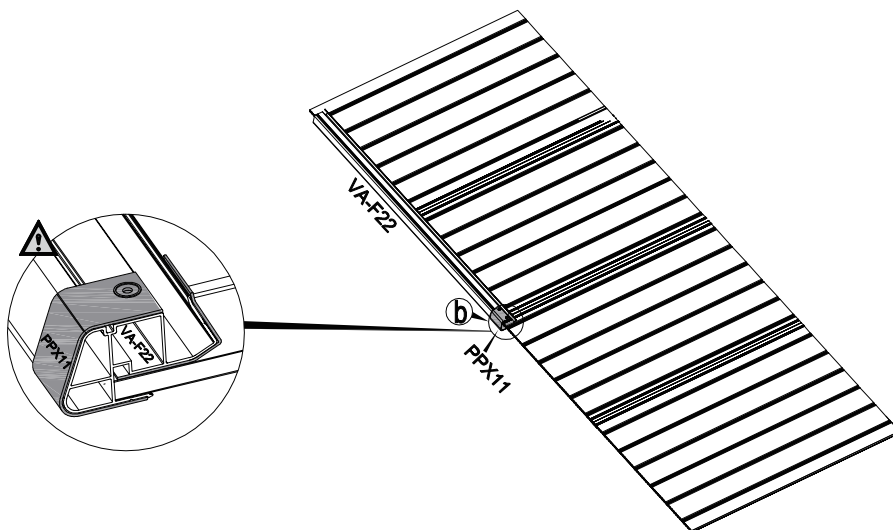
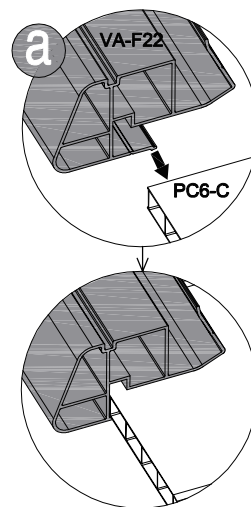
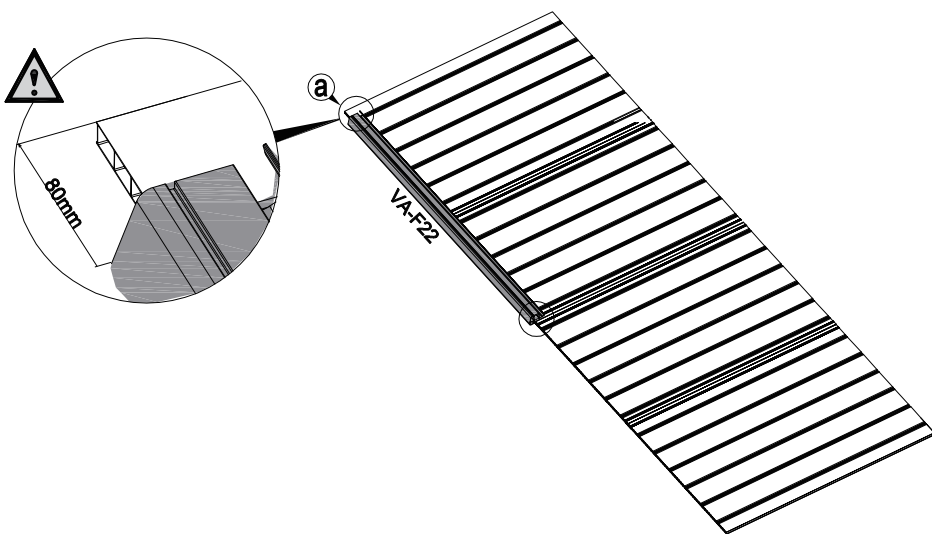

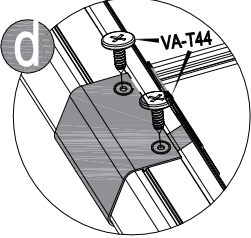
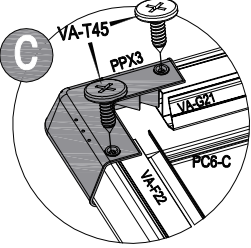
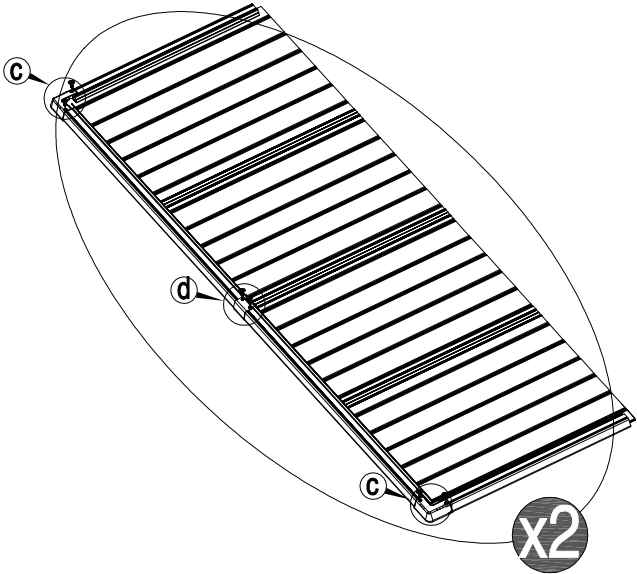
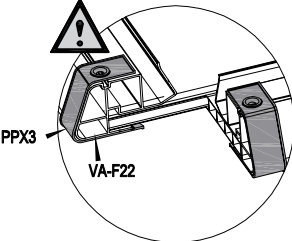
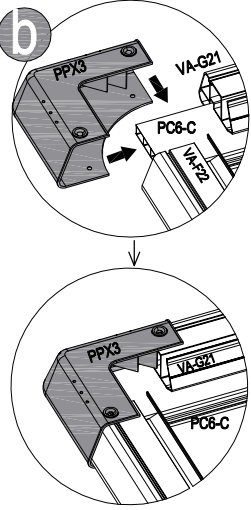
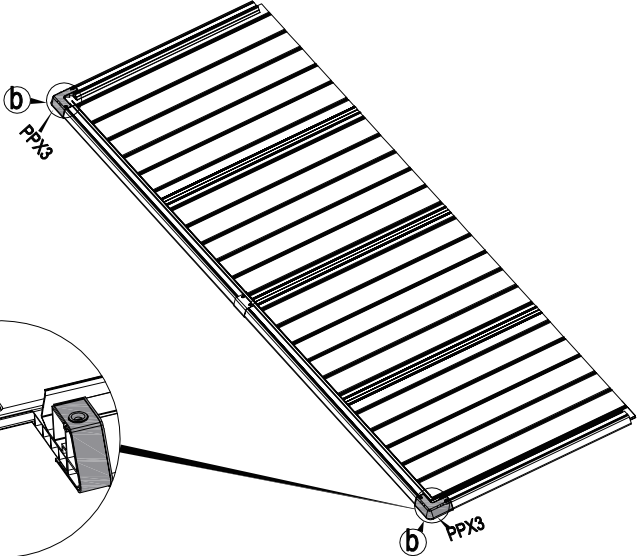
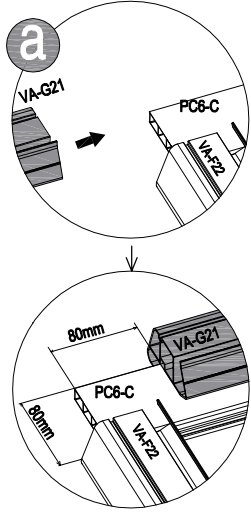
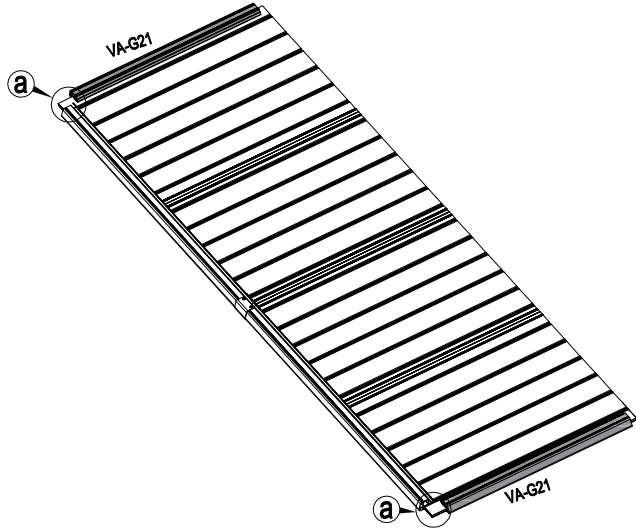
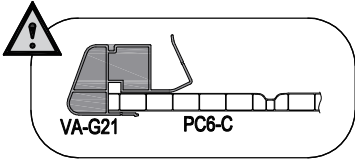

CN-A33

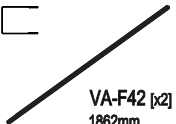

39	 VA-G21 [x4] 1165mm	 PPX3[x4]	 VA-T44 [x4] 13mm	 VA-T45 [x8] 19mm		 CN-A33
----	--	---	--	--	--	---



40	 VA-F42 [x2] 1862mm	 VA-F41 [x2] 1863mm	 VA-T45 [x28] 19mm	 VA-T46 [x10] 13mm	 VA-T44 [x12] 13mm	 CN-A33	
----	--	--	---	---	---	---	--

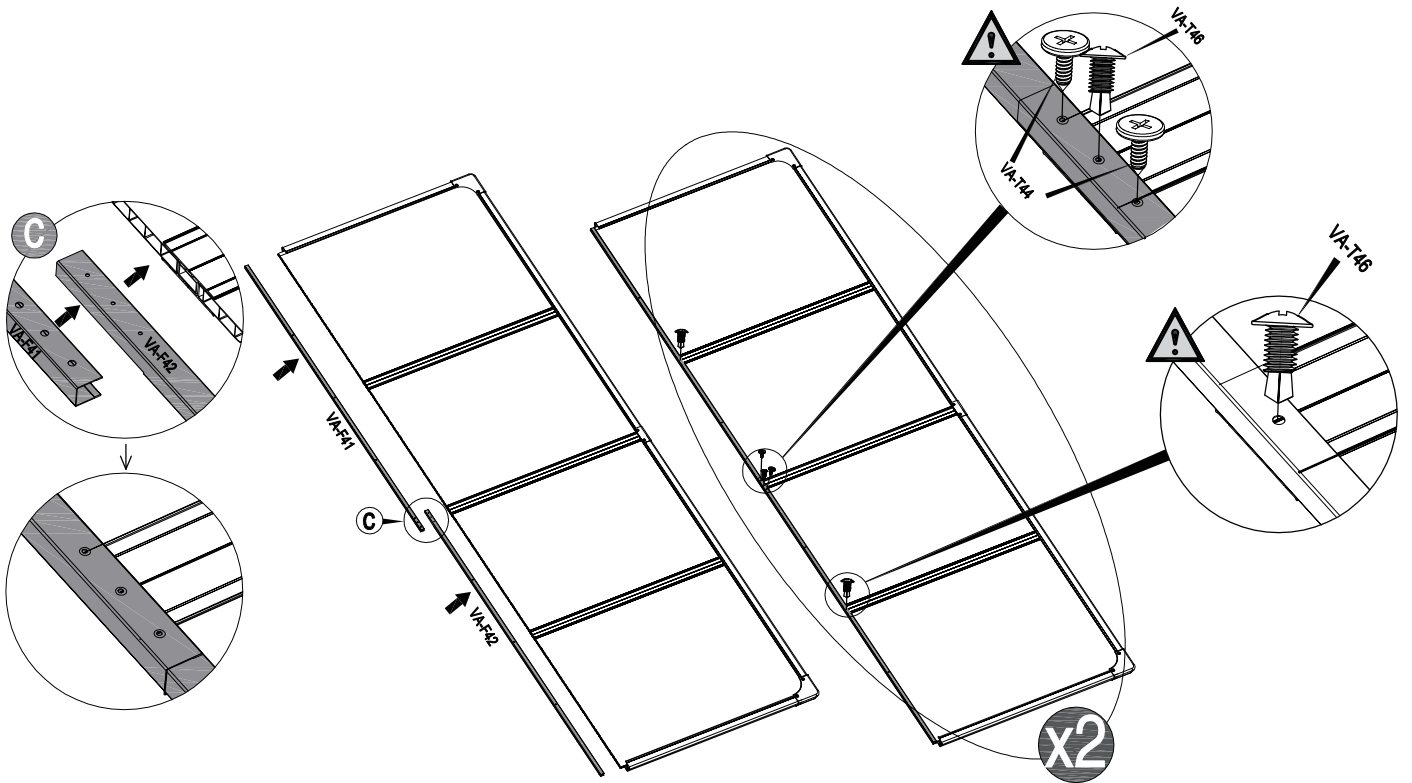
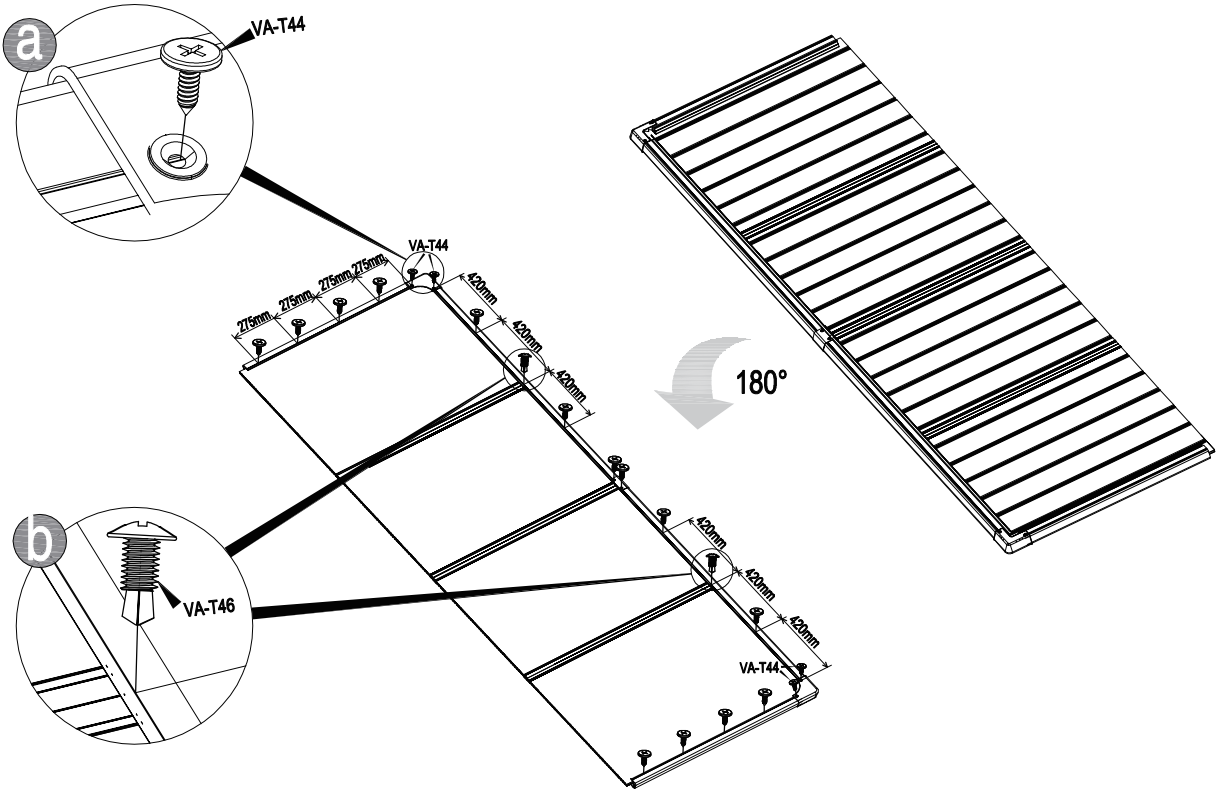

41



CN-A33

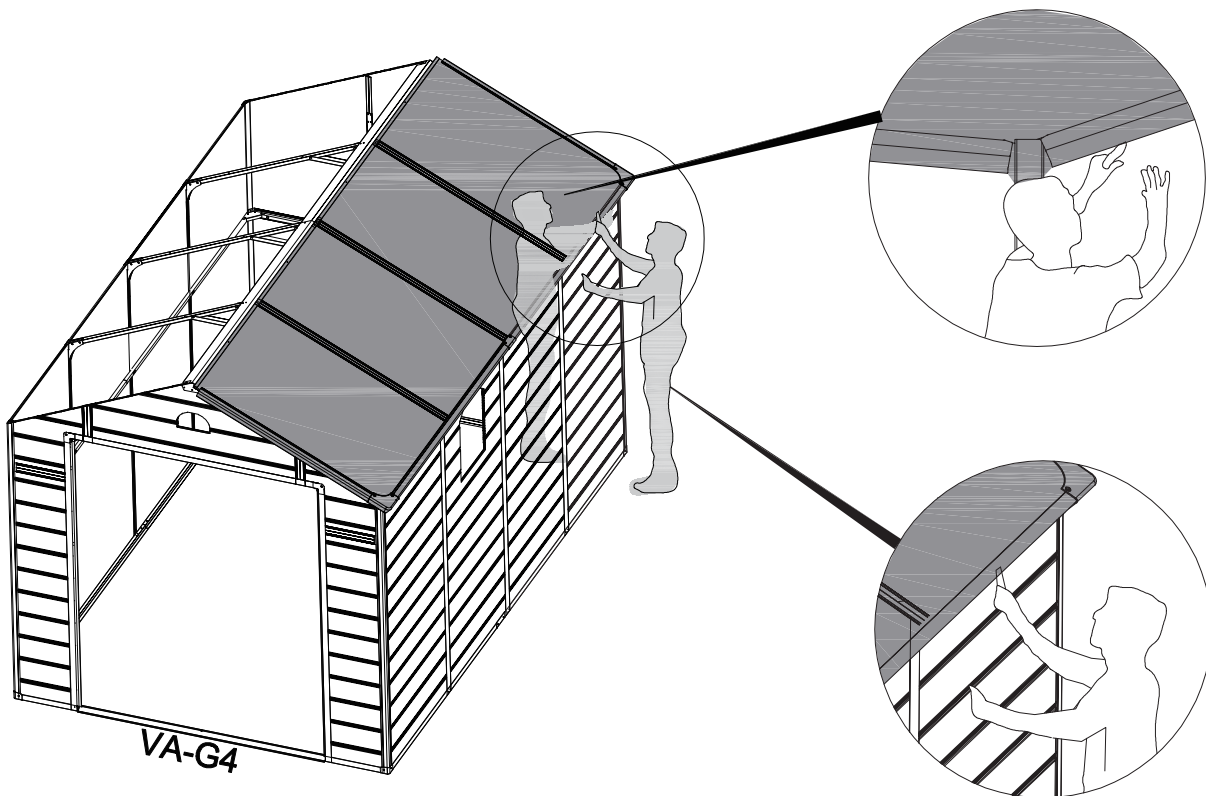
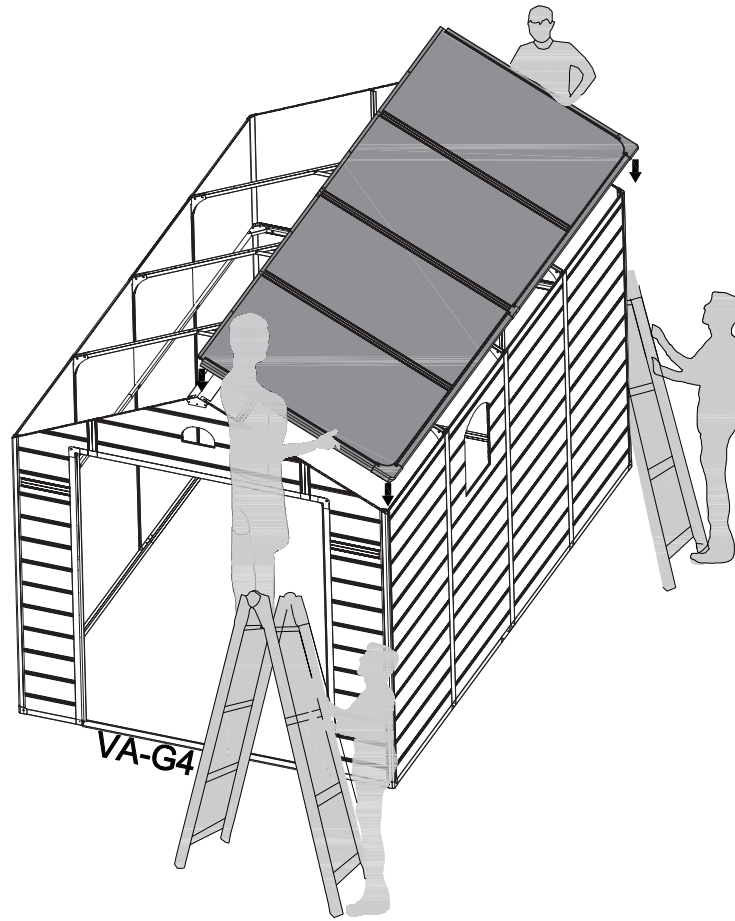
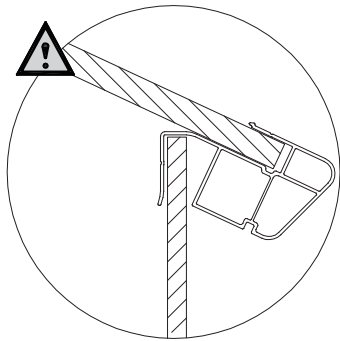
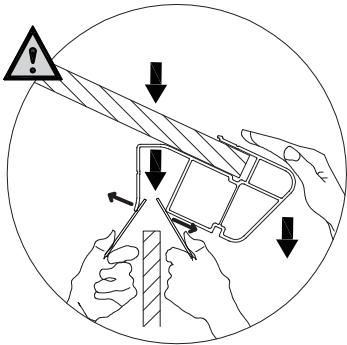

42



CN-A33

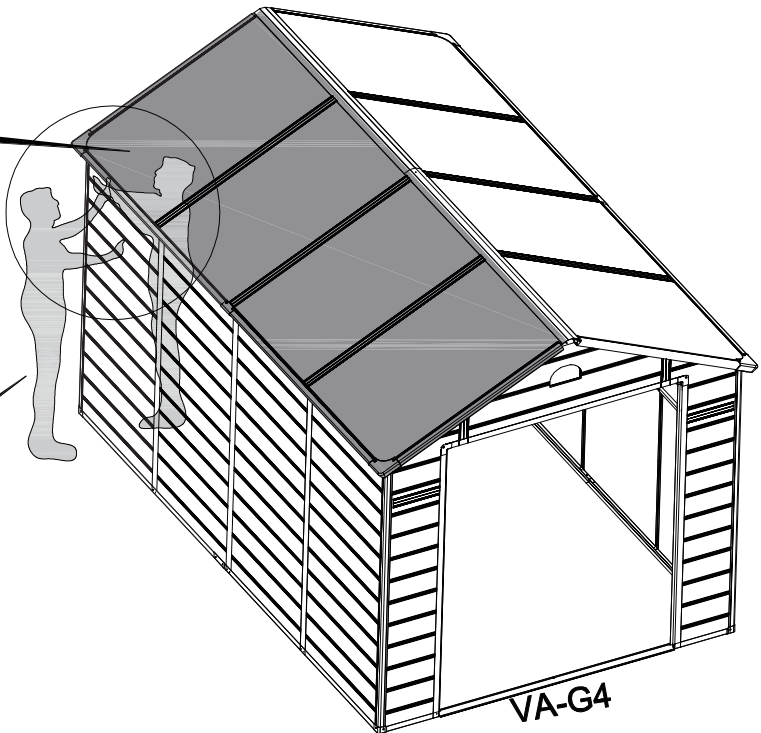
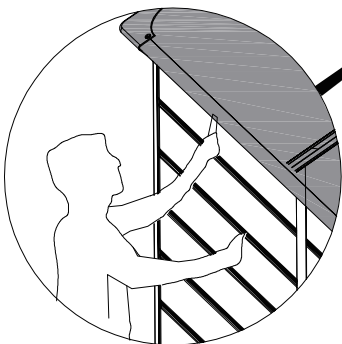
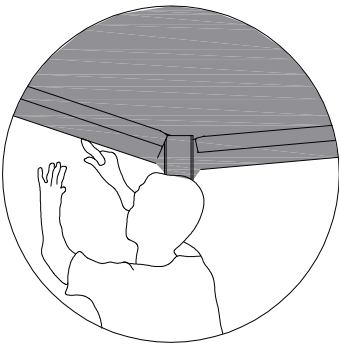
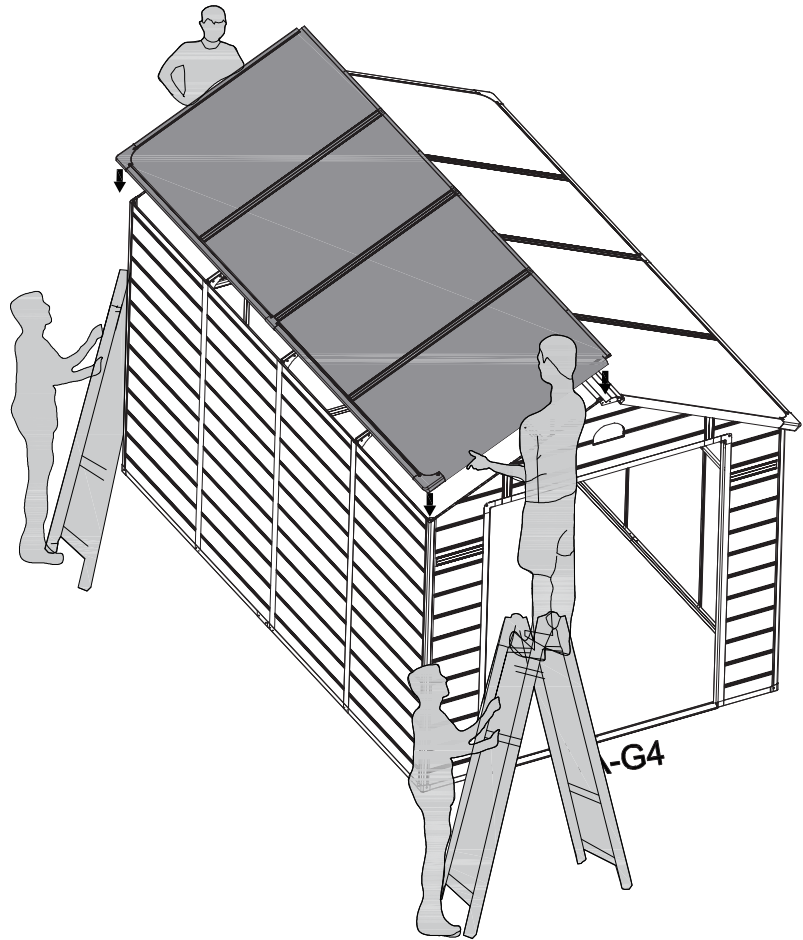
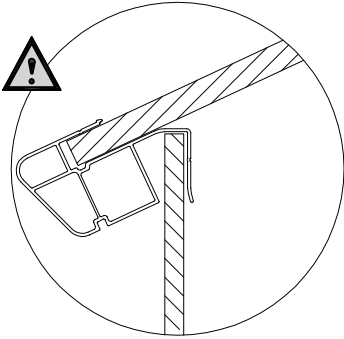
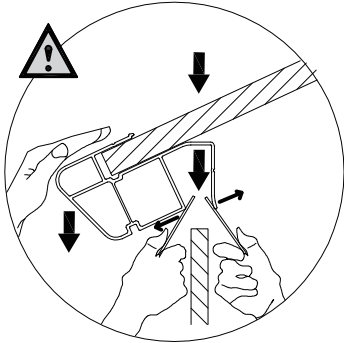
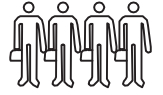

43



VA-T45 [x36]
19mm



VA-T46 [x12]
13mm

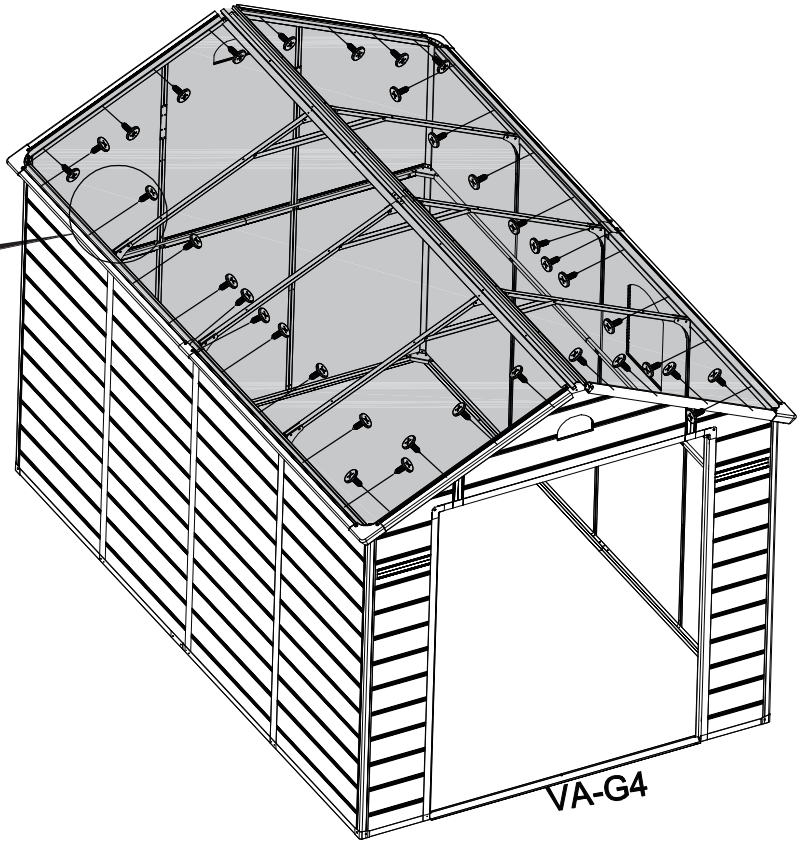
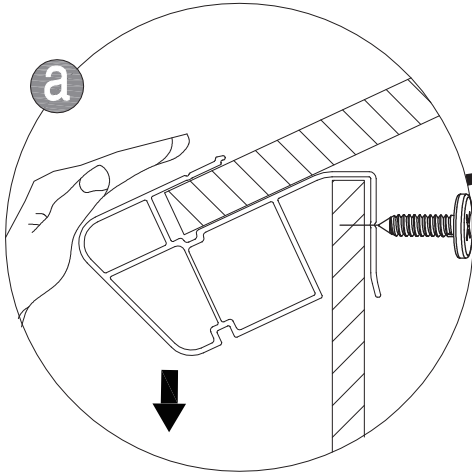

VA-G4

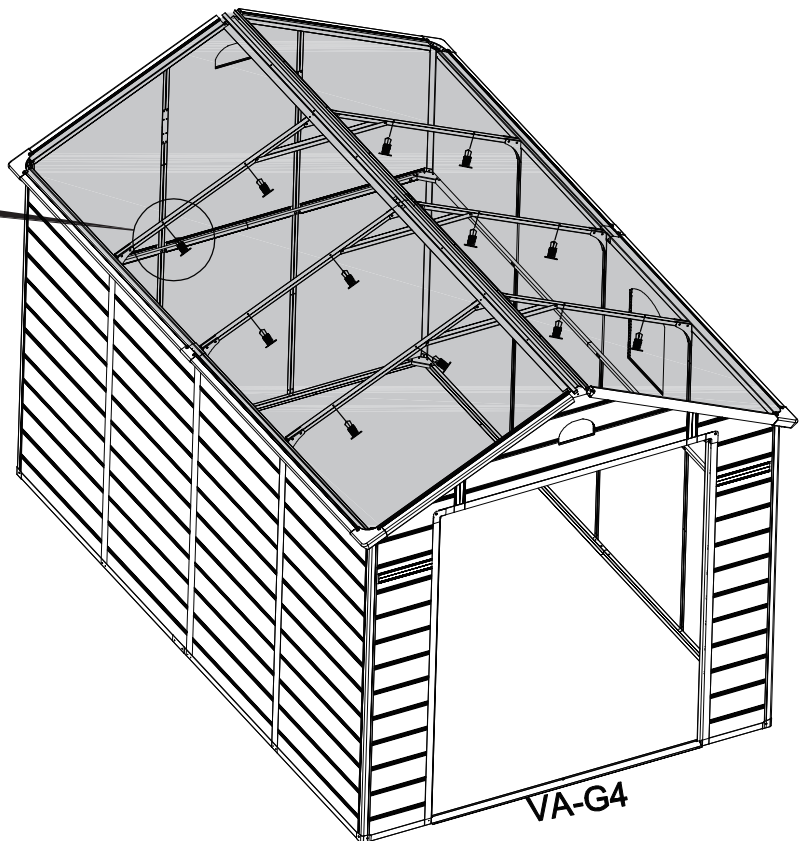
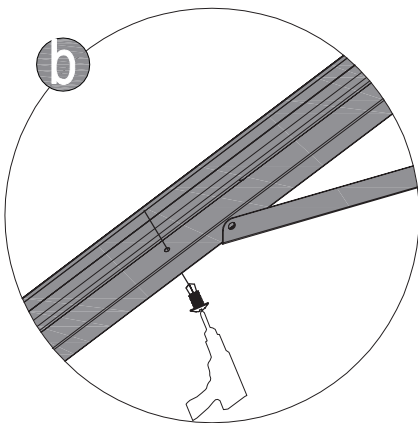

VA-G4

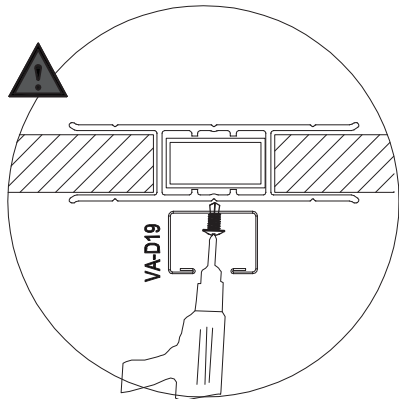

44

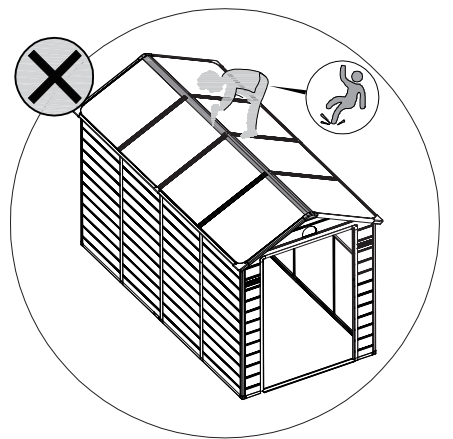
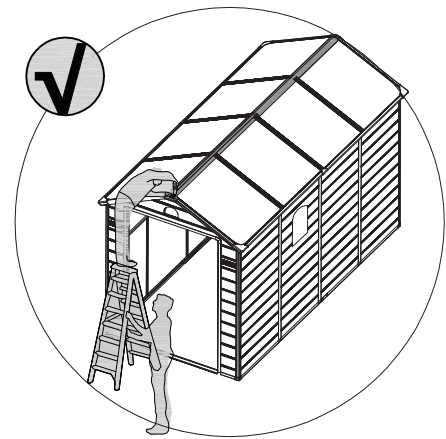
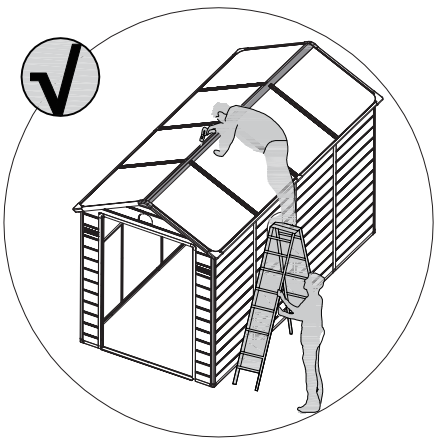
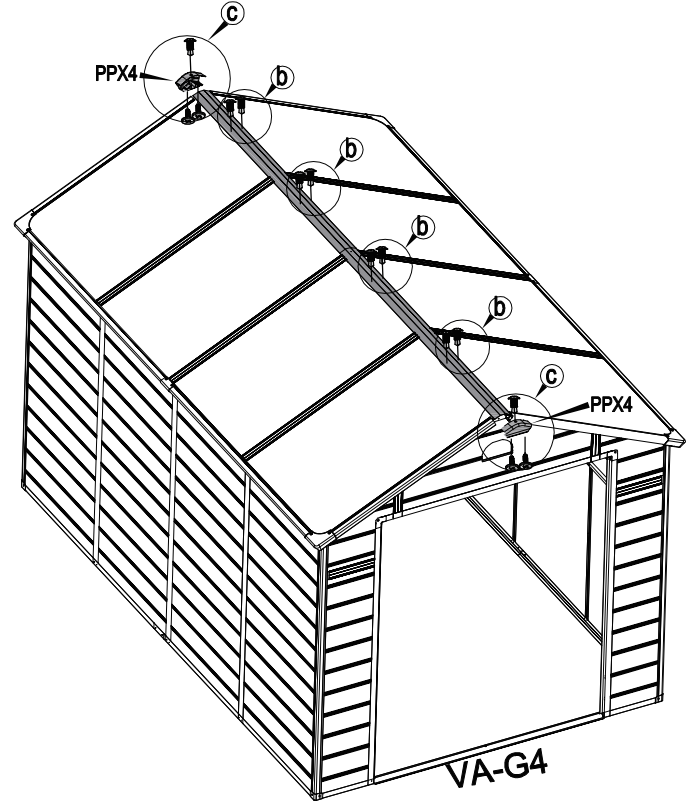
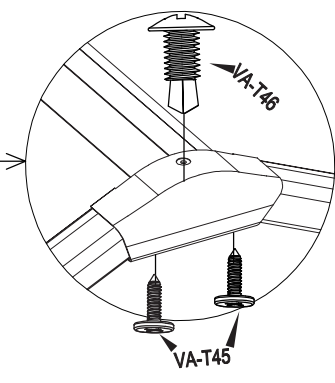
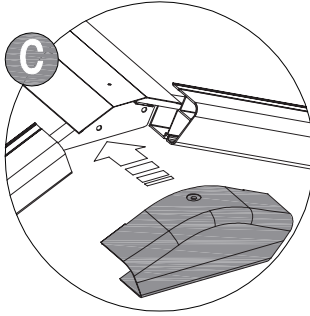
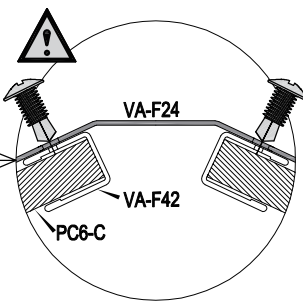
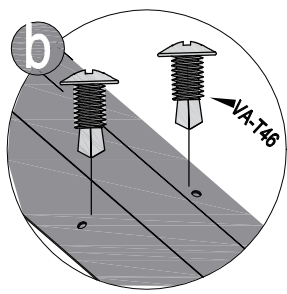
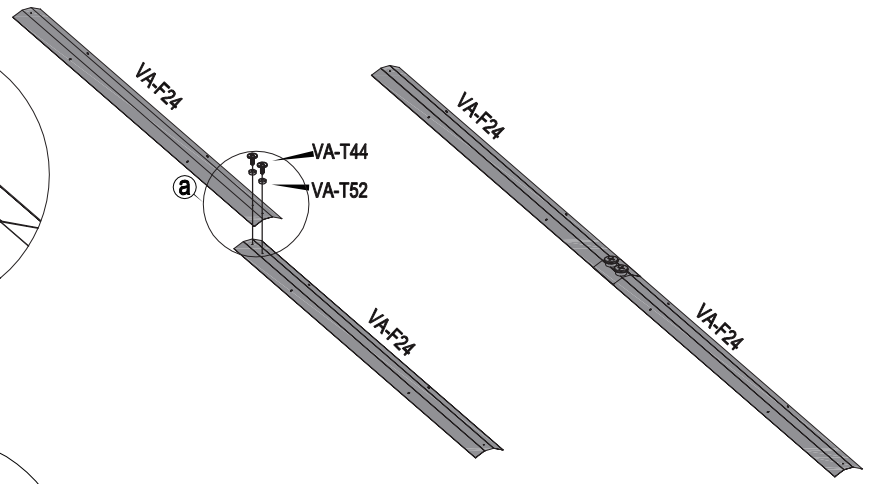
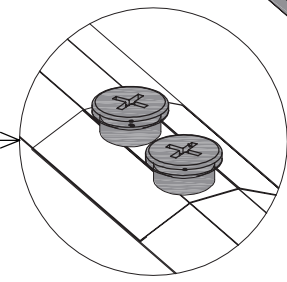
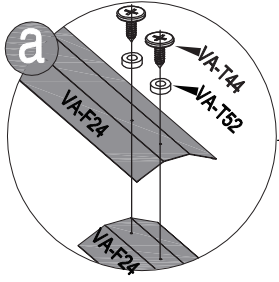
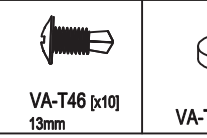
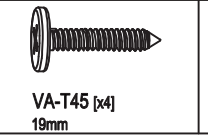
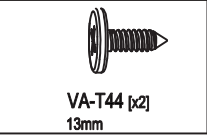
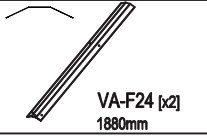

45

PC7S [x1]
1810x746mm

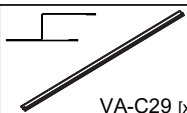

VA-C29 [x1]
1812mm

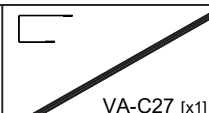

VA-C27 [x1]
1812mm

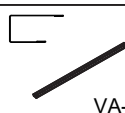

VA-C28 [x2]
592mm



VA-T44 [x14]
13mm

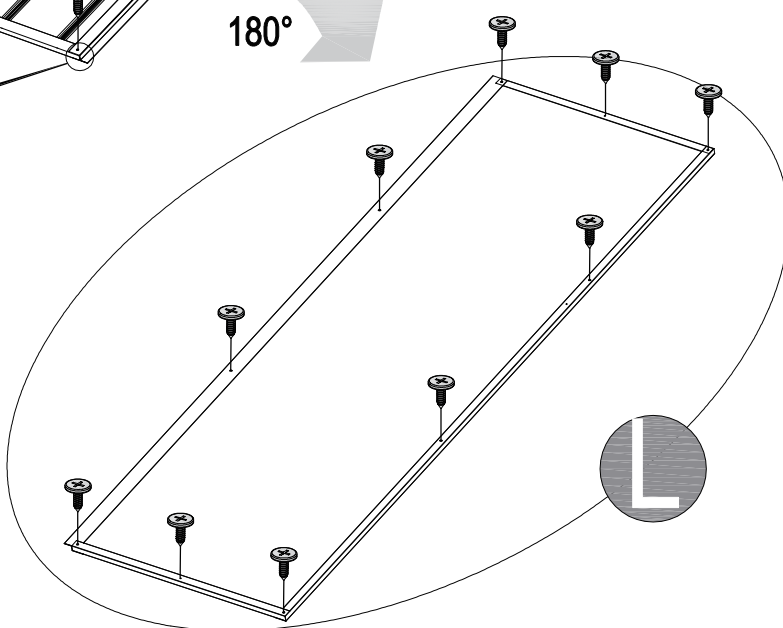
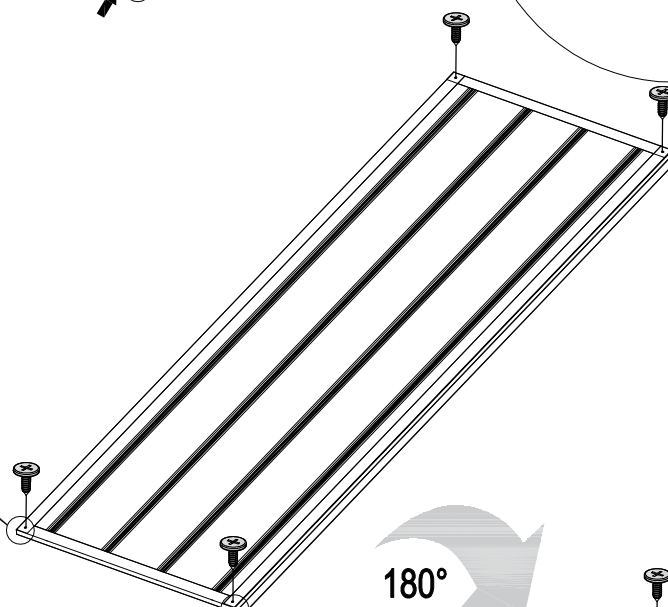
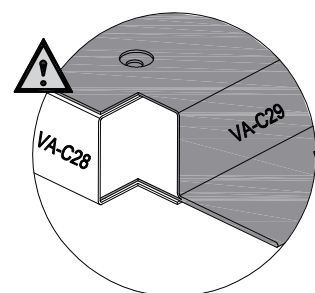
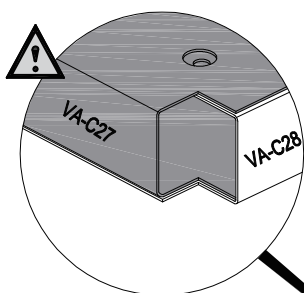
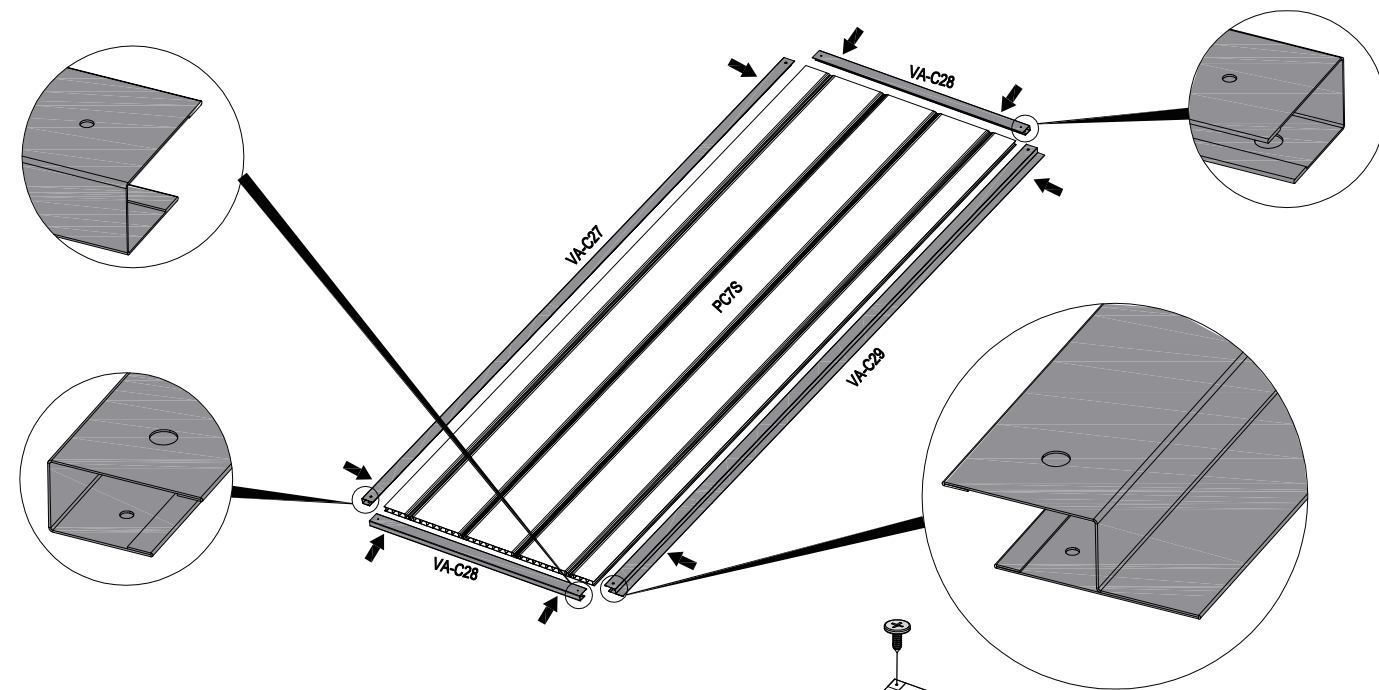

46

PC7S [x1]
1810x746mm

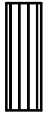

VA-C27 [x2]
1812mm

VA-C28 [x2]
592mm

VA-T44 [x14]
13mm

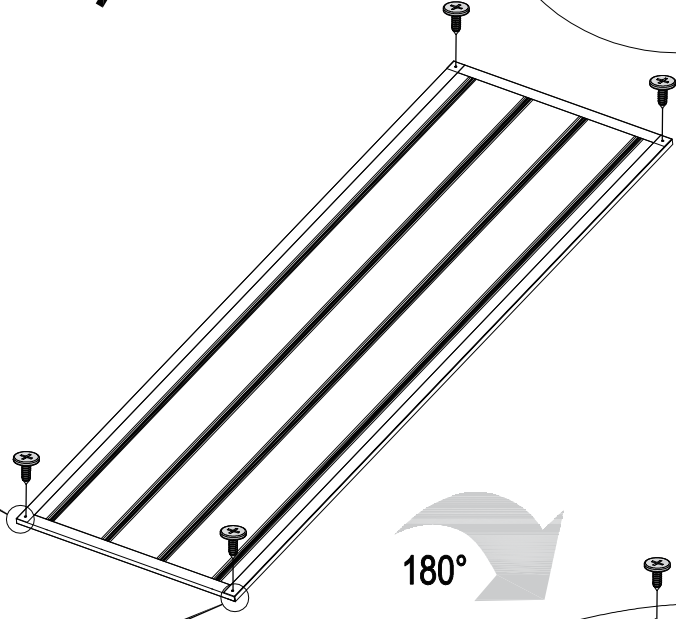
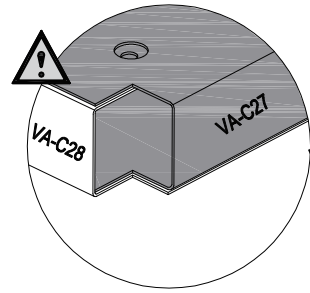
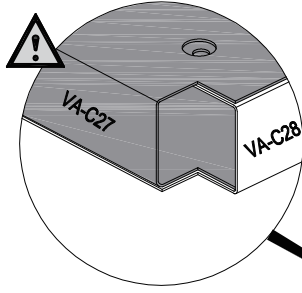
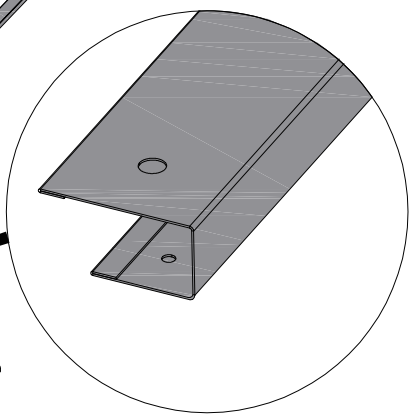
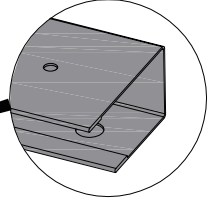
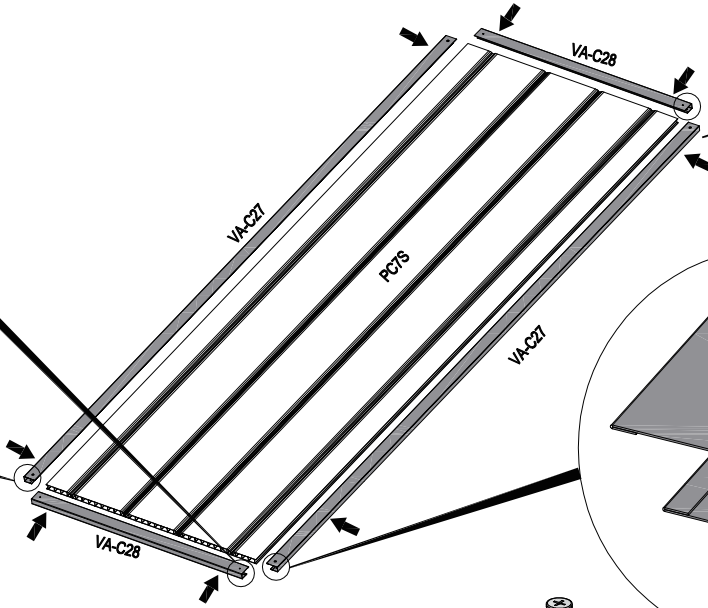
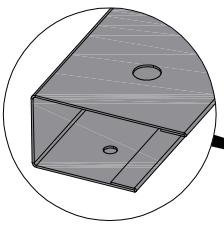
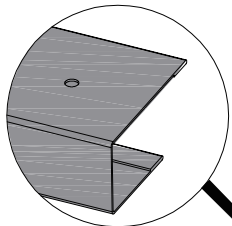

180°

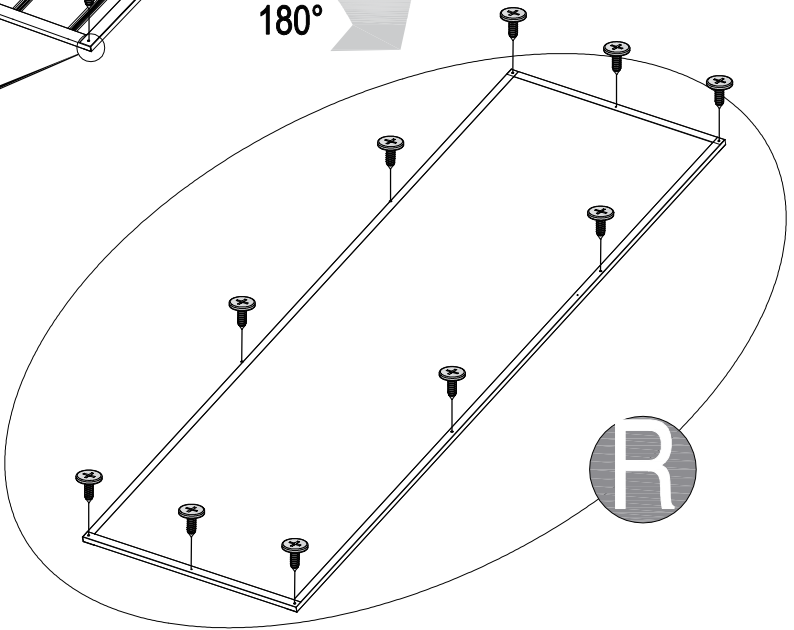

47



VA-41 [x4]



VA-40 [x1]



PA01 [x3]



VA-T45 [x3]
19mm



VA-T44 [x36]
13mm



Ø2.5mm

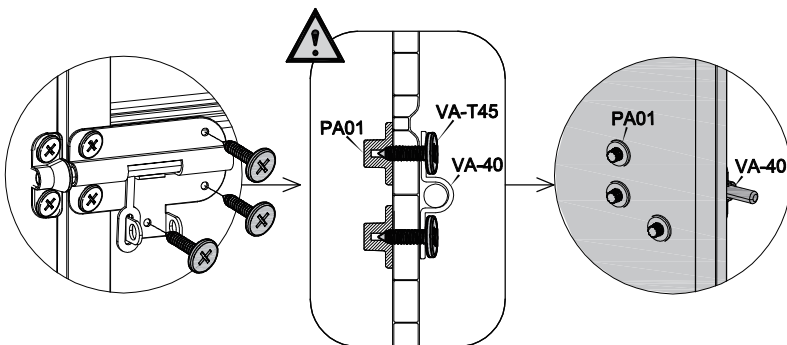
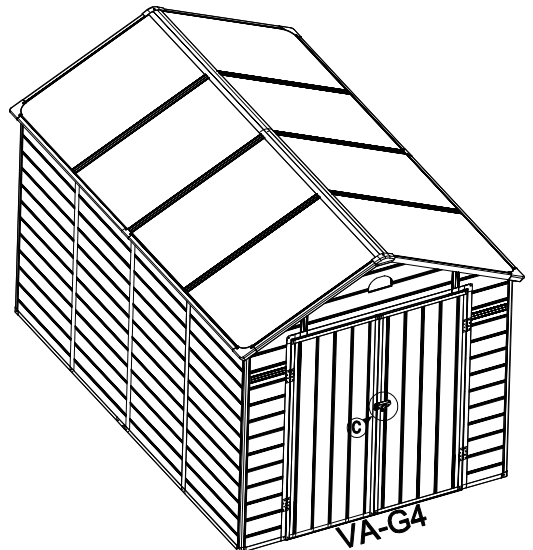
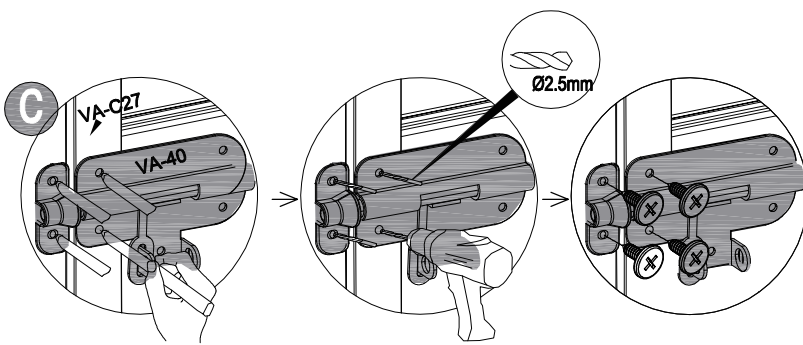
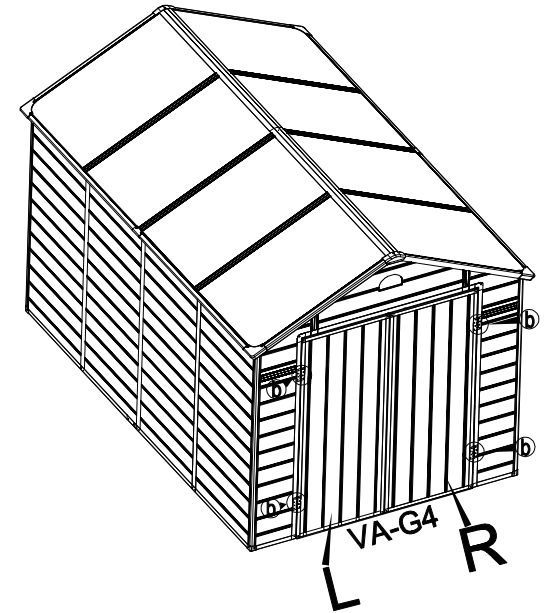
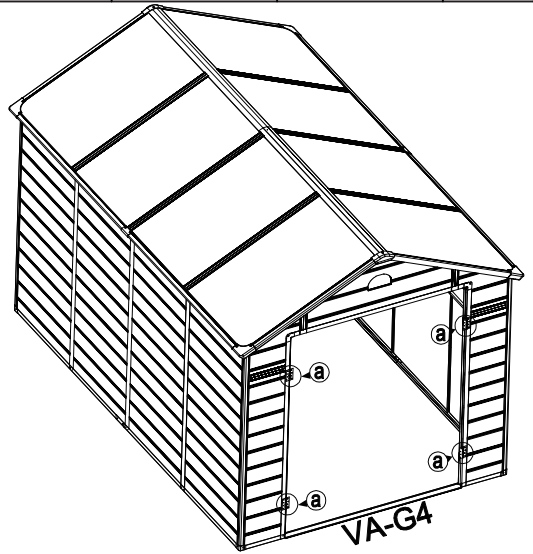
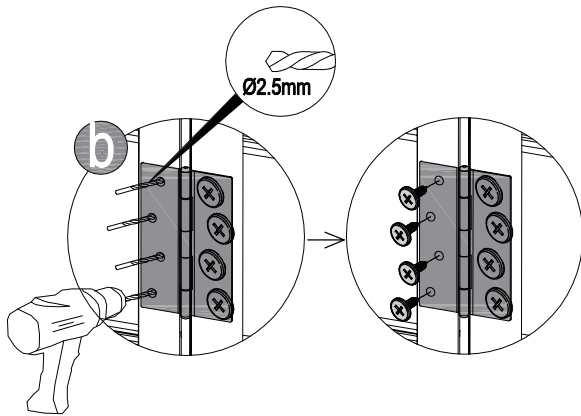
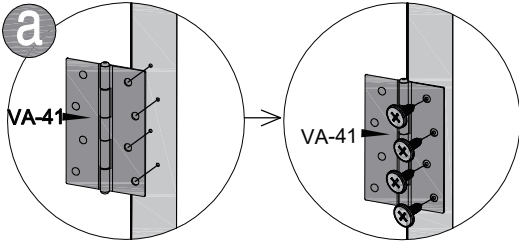

48



VA-38a [x2]

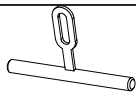

VA-38b [x2]



VA-39 [x2]



VA-T49 [x8]
13mm



Ø2.5mm

a

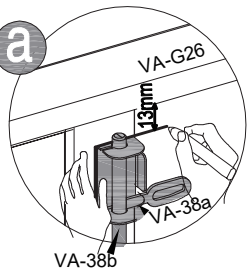

VA-38b

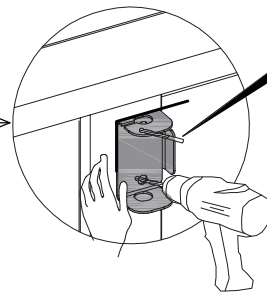
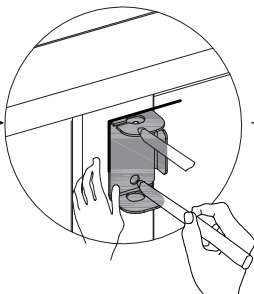
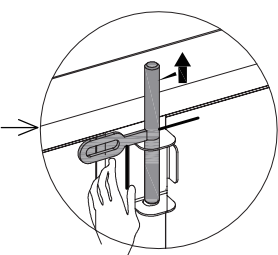

Ø2.5mm

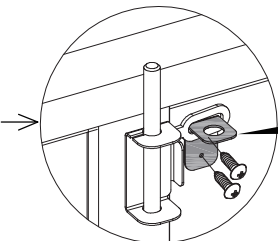
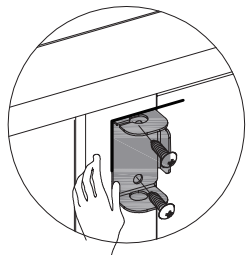

VA-39

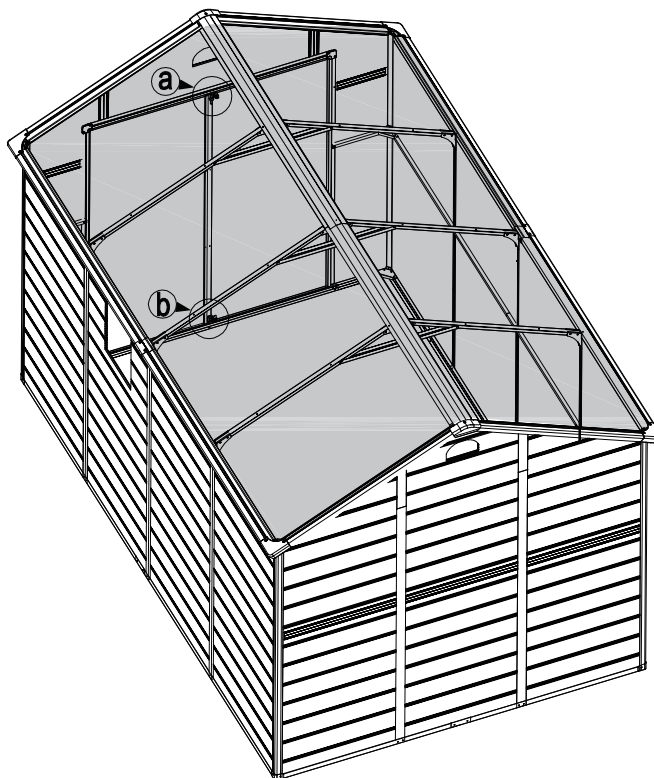

b

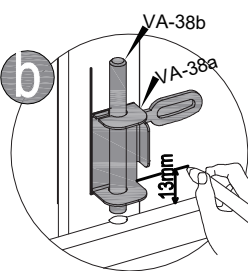

VA-38b

VA-38a

13mm

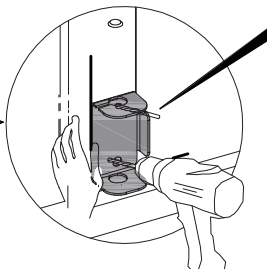
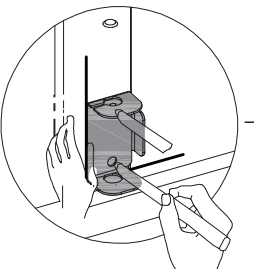
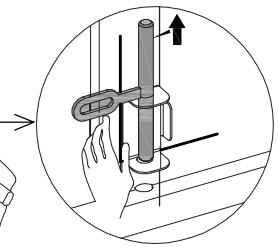

Ø2.5mm

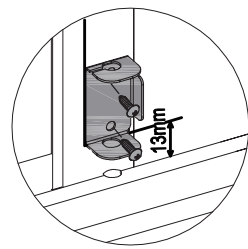

13mm

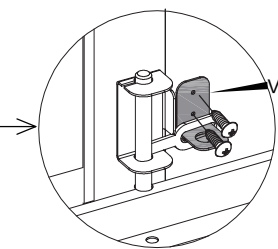

VA-39

49



VA-36 [x2]



VA-32L [x2]



VA-32R [x2]



VA-37b [x8]



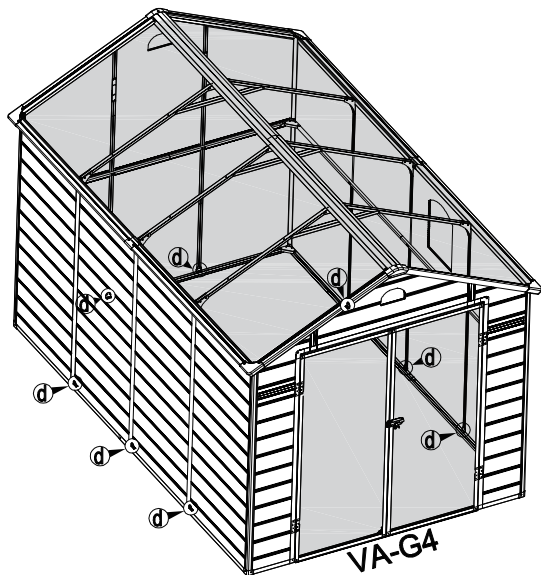
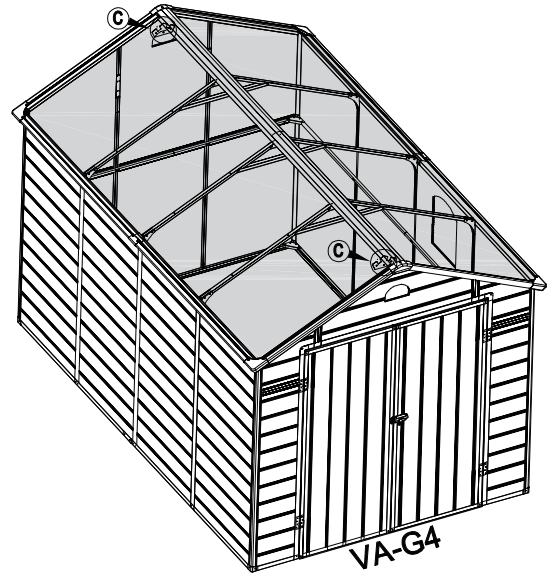
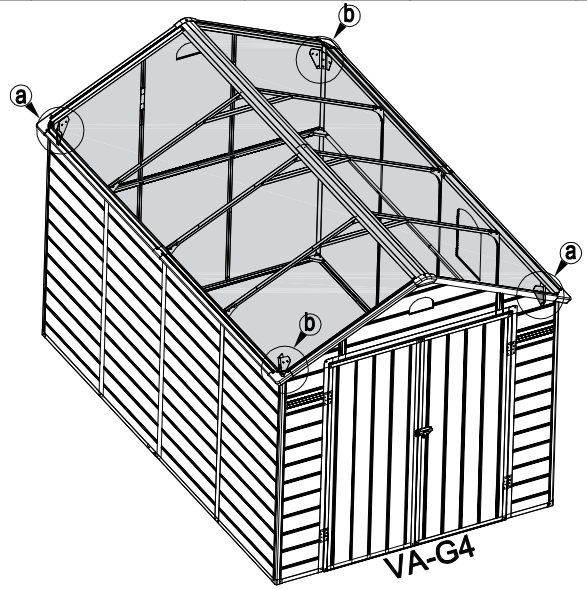
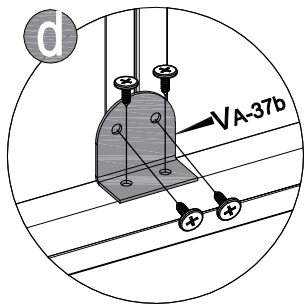
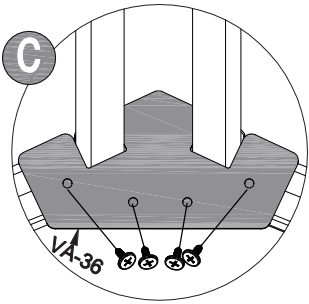
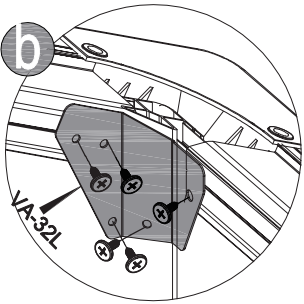
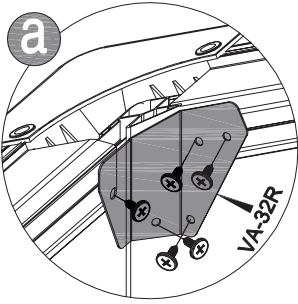

VA-T44 [x60]
13mm

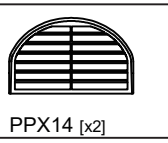
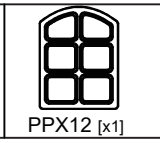
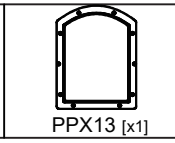
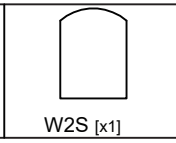
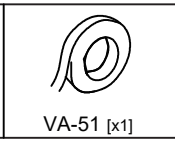
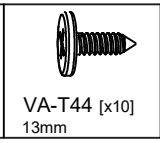
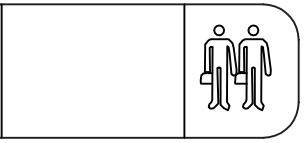

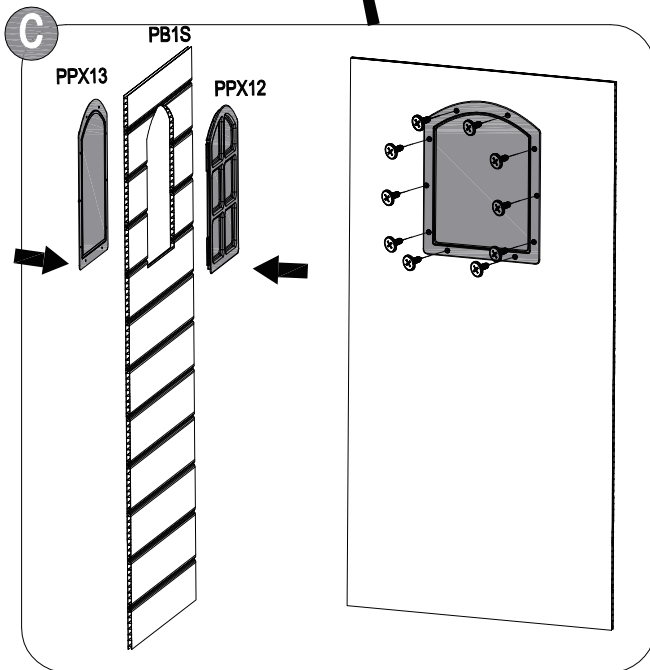
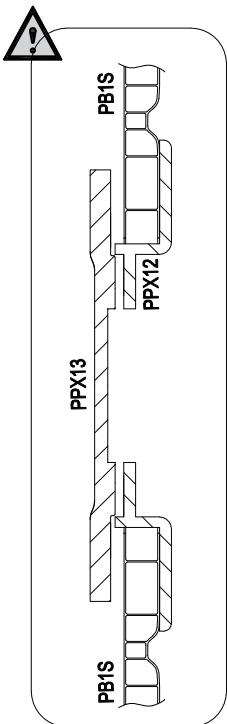
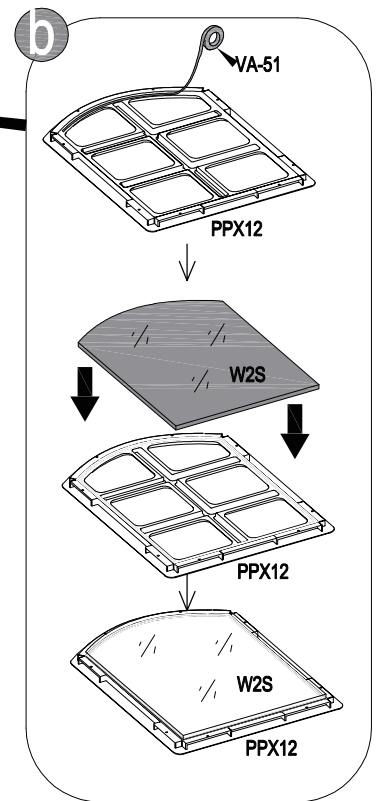
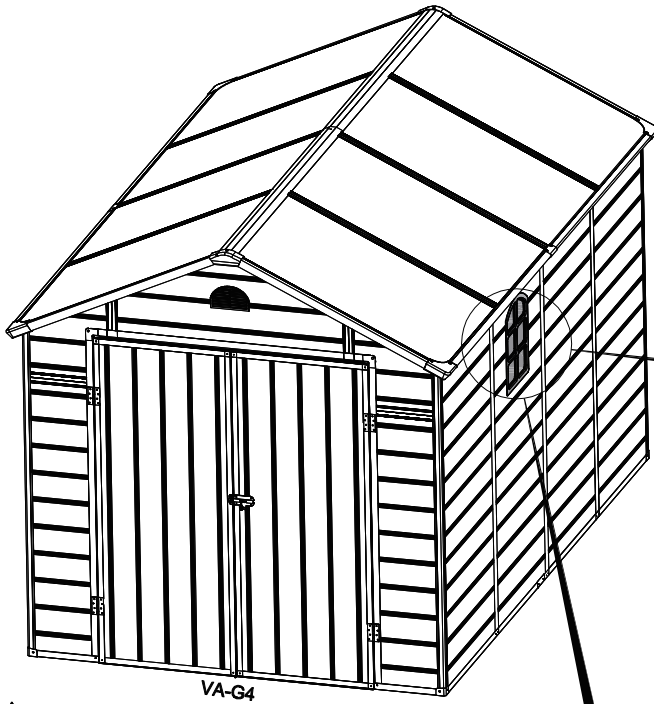
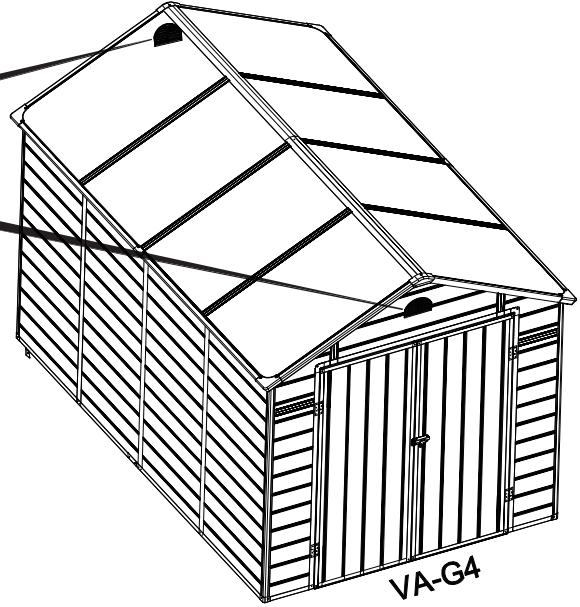
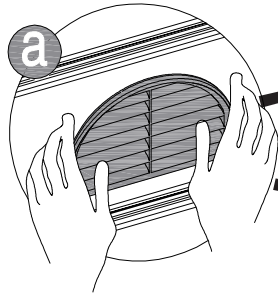
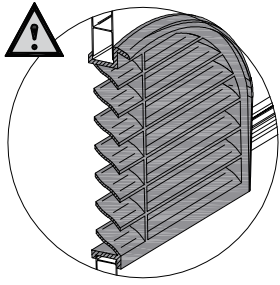
50	 PPX14 [x2]	 PPX12 [x1]	 PPX13 [x1]	 W2S [x1]	 VA-51 [x1]	 VA-T44 [x10] 13mm	
----	---	---	---	---	--	---	---



51	 VA-DB07 [x6] 735x1740mm	 VA-55 [x2]	 VA-55b [x1]		
----	---	---	--	--	---

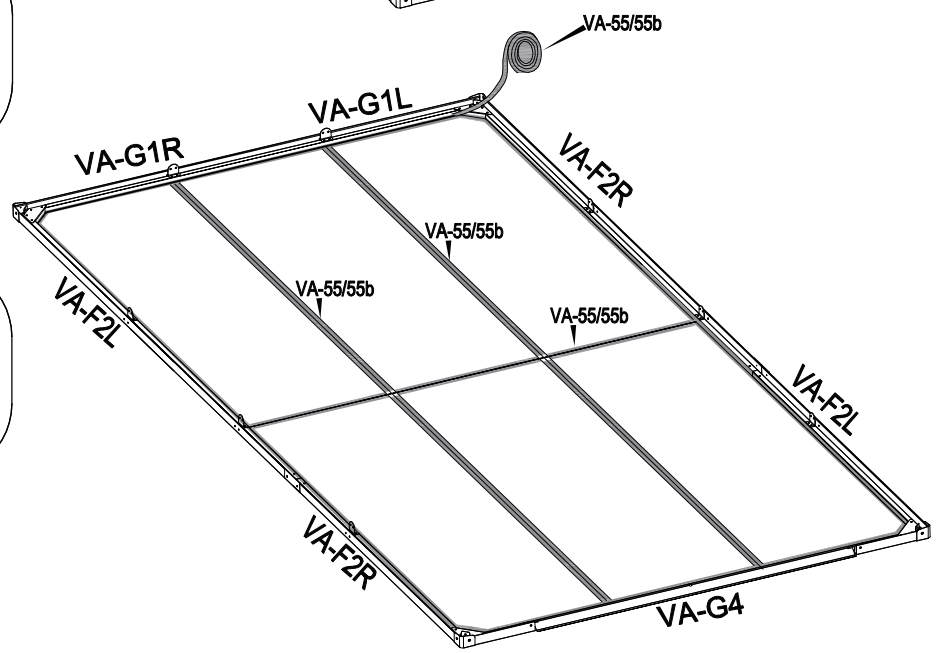
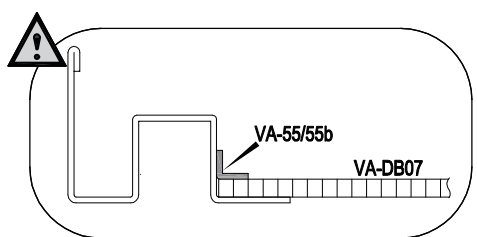
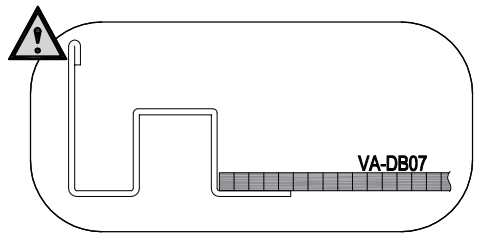
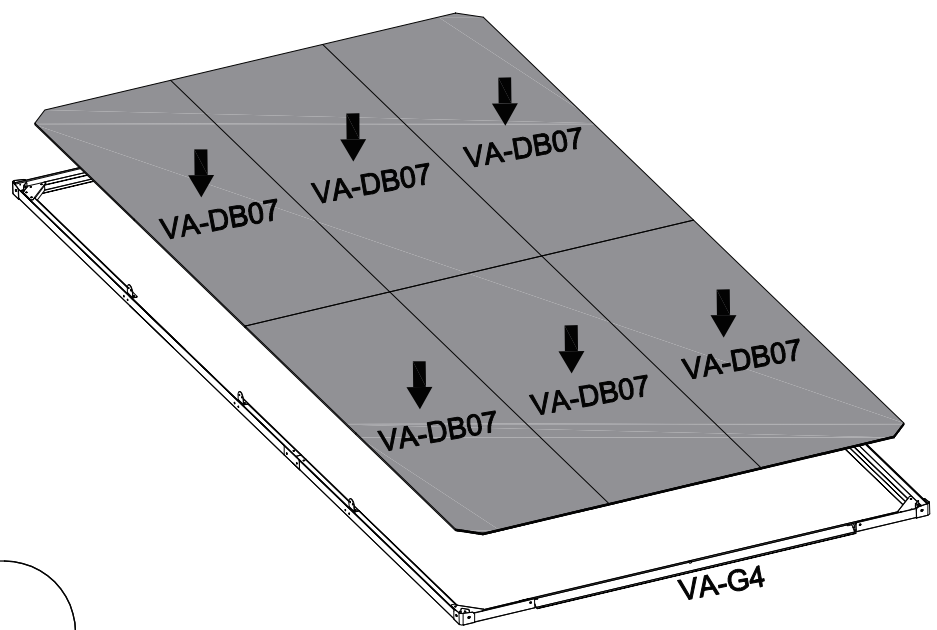
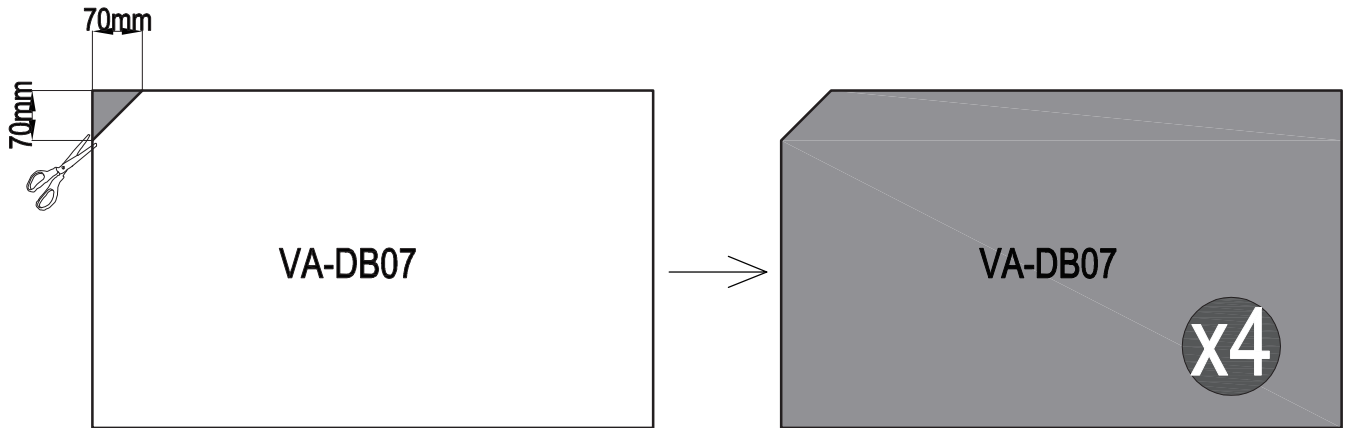

Thank you for choosing Oakville furniture Patio Storage Shed. We take pride in delivering a high-quality product that is designed to enhance your outdoor living space and provide reliable storage solutions. To ensure your satisfaction and peace of mind, we offer the following limited warranty and important information regarding caution and maintenance. Please read this carefully.

Limited Warranty

- We stand behind the quality of our Patio Storage Shed and offer a limited warranty to the original purchaser. The warranty covers defects in materials and workmanship for a period of 3 years from the date of purchase. During this warranty period, we will repair or replace any parts or components that are found to be defective, free of charge.
- Please note that the warranty does not cover damages resulting from improper installation, misuse, abuse, neglect, accidents, or natural disasters. It also does not cover damages caused by unauthorized modifications or repairs.
- To make a warranty claim, please contact our customer service team with your proof of purchase and a detailed description of the issue. Our team will guide you through the process and ensure a prompt resolution.

E-mail: marketing2@oakvillefurnitures.com

Call Toll Free: 1-(888)-682-8882

15257 Don Julian Road, City of industry 91745, U.S.A.

Important Information

- **Cautious Handling:** When assembling or moving the Patio Storage Shed, please exercise caution and follow the provided instructions carefully. Seek assistance if needed, as the shed's components can be heavy. Take care to avoid personal injury and property damage during the installation process.
- **Proper Anchoring:** It is essential to properly anchor the Patio Storage Shed to the ground or a suitable foundation. This will ensure stability and prevent damage caused by strong winds or extreme weather conditions. Use the recommended anchoring hardware and follow the instructions provided.
- **Regular Maintenance:** To keep your Patio Storage Shed in optimal condition, we recommend regular maintenance. Clean the shed periodically using mild soap and water, and avoid using abrasive cleaners or solvents that may damage the materials. Inspect the shed for any signs of wear, loose fittings, or damage, and address them promptly to prevent further issues.
- **Snow Removal:** In areas with heavy snowfall, it is important to remove snow from the roof of the shed to prevent excessive weight and potential collapse. Use a soft-bristle brush or a snow rake to carefully remove snow buildup, avoiding any damage to the shed's surface.
- **Ventilation and Moisture Control:** Our Patio Storage Shed is designed with built-in ventilation to ensure proper air circulation. However, it is advisable to periodically check for any moisture buildup inside the shed. Keep the vents clear and address any condensation issues promptly to prevent damage to stored items.
- **Safety and Security:** The Patio Storage Shed features lockable doors for added security. We recommend utilizing the locking mechanism to safeguard your belongings. Additionally, ensure that the shed is placed in a secure location within your property to deter unauthorized access.

Please retain your proof of purchase and warranty information for future reference.

For any questions, concerns, or warranty claims, please contact our customer service team. We are here to assist you and provide the necessary support.

Thank you once again for choosing our Patio Storage Shed. We hope it brings you years of reliable storage and enjoyment for your outdoor space.