

Accessory list

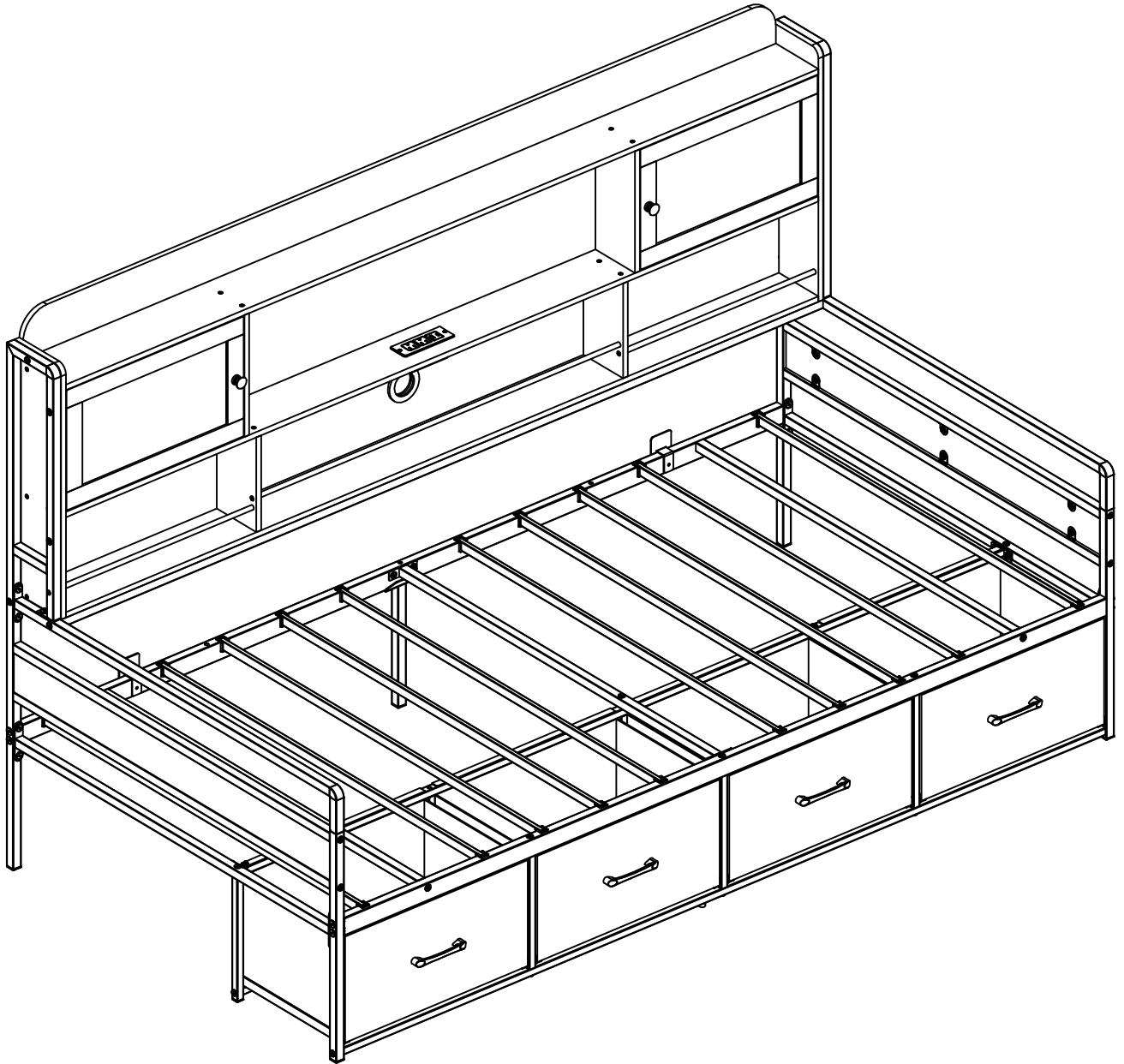

AJ-DJ505067

Version : 2.0

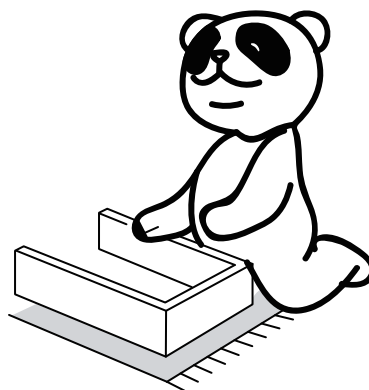
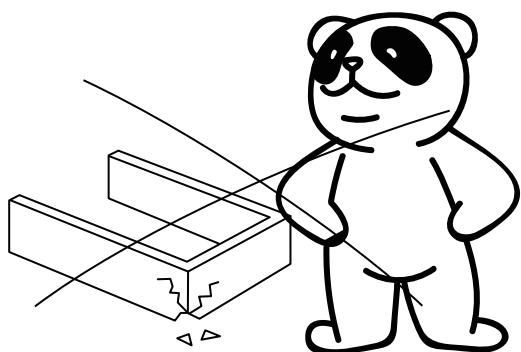
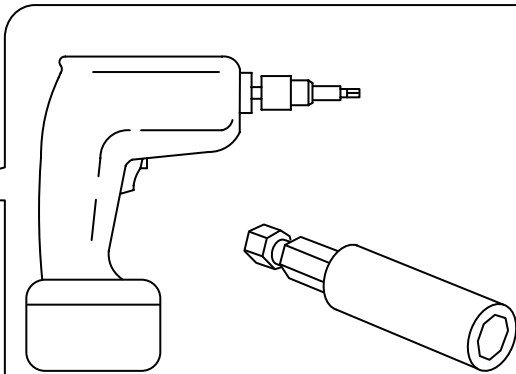

Violent installation is prohibited

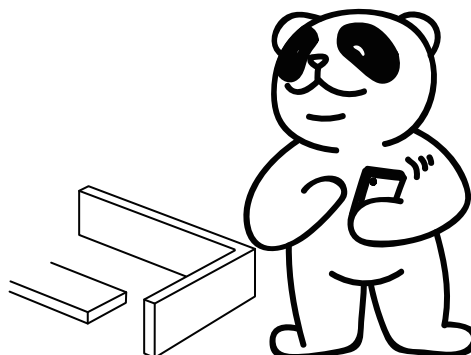
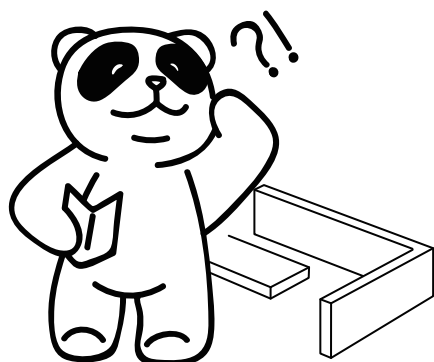

Please call if you need help

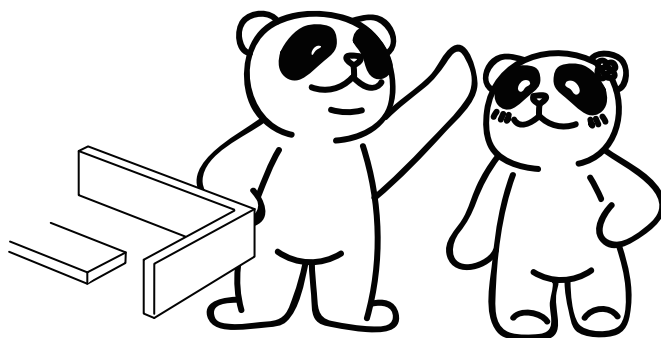
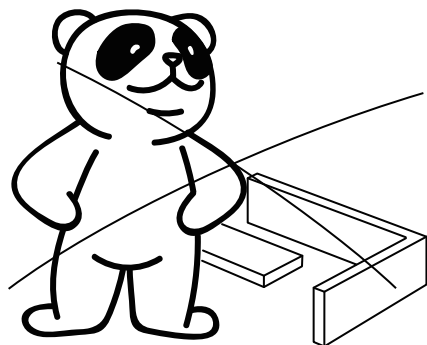

Multi-person cooperation is recommended

Assembly Instruction



1
x2

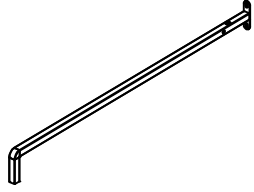

2
x2



3
x1



4
x1

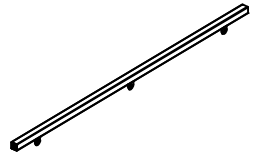

5
x4



6
x1

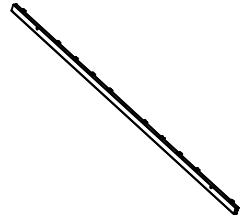

7
x2

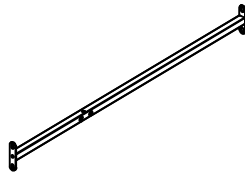

8
x1

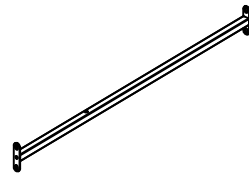

9
x1

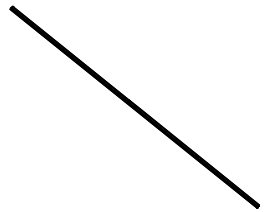

10
x2

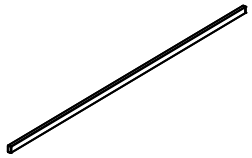

11
x10

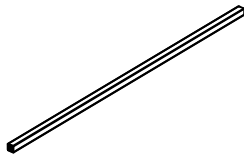

12
x2

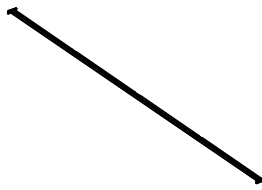

13
x1



14
x6



15
x2

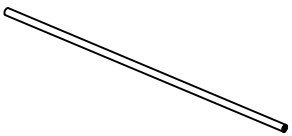

16
x2

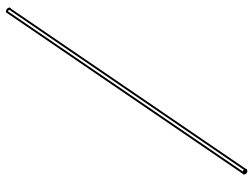

17
x1

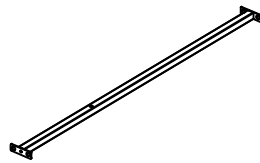

18
x1

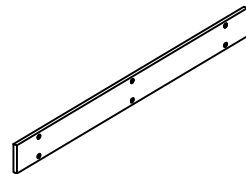

19
x2



20
x1



21
x1

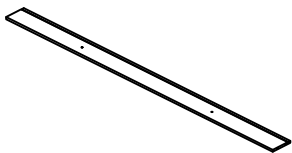

22
x1

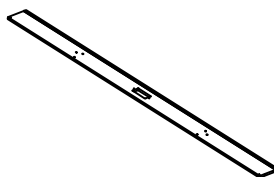

23
x1

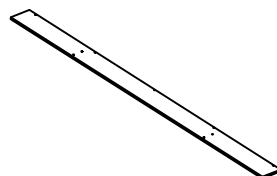

24
x1

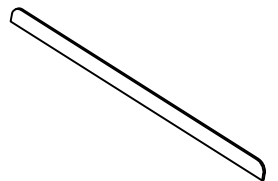

25
x1

Assembly Instruction

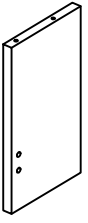

26
x2

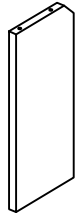

27
x1

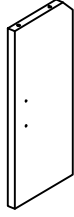

28
x1

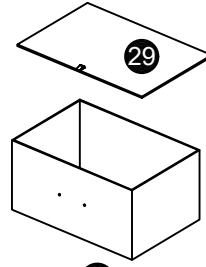

29
x4

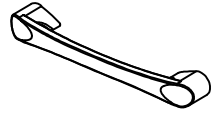

30
x4

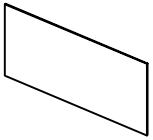

31
x2

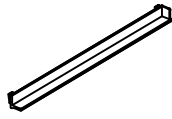

32
x4

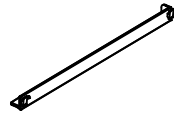

33
x4

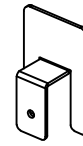

34
x2

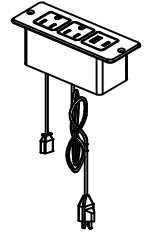

35
x1

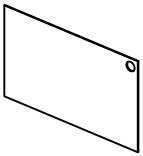

36
x2

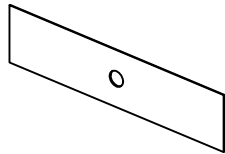

37
x1

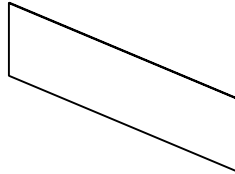

38
x1

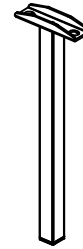

39
x1

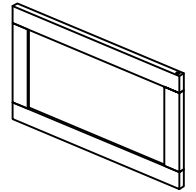

40
x2

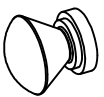

41
x2

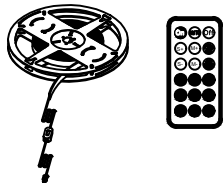

42
x1

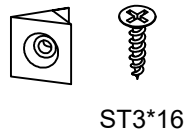

43
x8

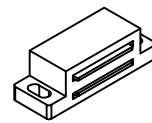

44
x2

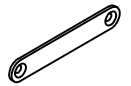

45
x2



46
x2

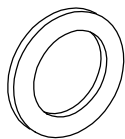

47
x1

Assembly Instruction

Hardware List



A
M6*10
x22+2

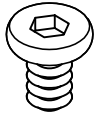

B
M8*15
x16+1

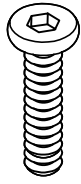

C
M6*40
x30+2

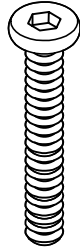

D
M6*60
x4

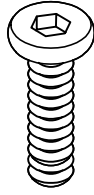

E
M8*40
x8



F
M4*22
x6

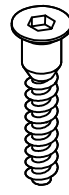

G
ST5*35
x29+2



H
ST3*15
x4



I
ST3*12
x6



J
Ø5*15
x4

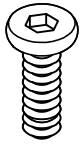

K
M6*28
x12+1



L
S3
x1

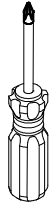

M
x1



N
S5
x1

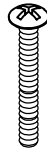

O
M4*40
x2



P
M4*12
x8

Assembly Instruction

Note:

- 1, should be assembled on flat ground to keep balance.
- 2, Before completing the installation, do not tighten the screws.

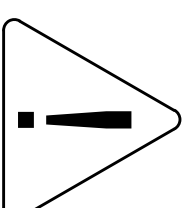
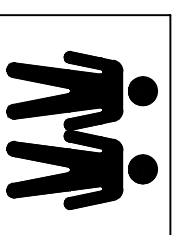

Before starting follow the the assembly. you must read the whole manual and instructions.

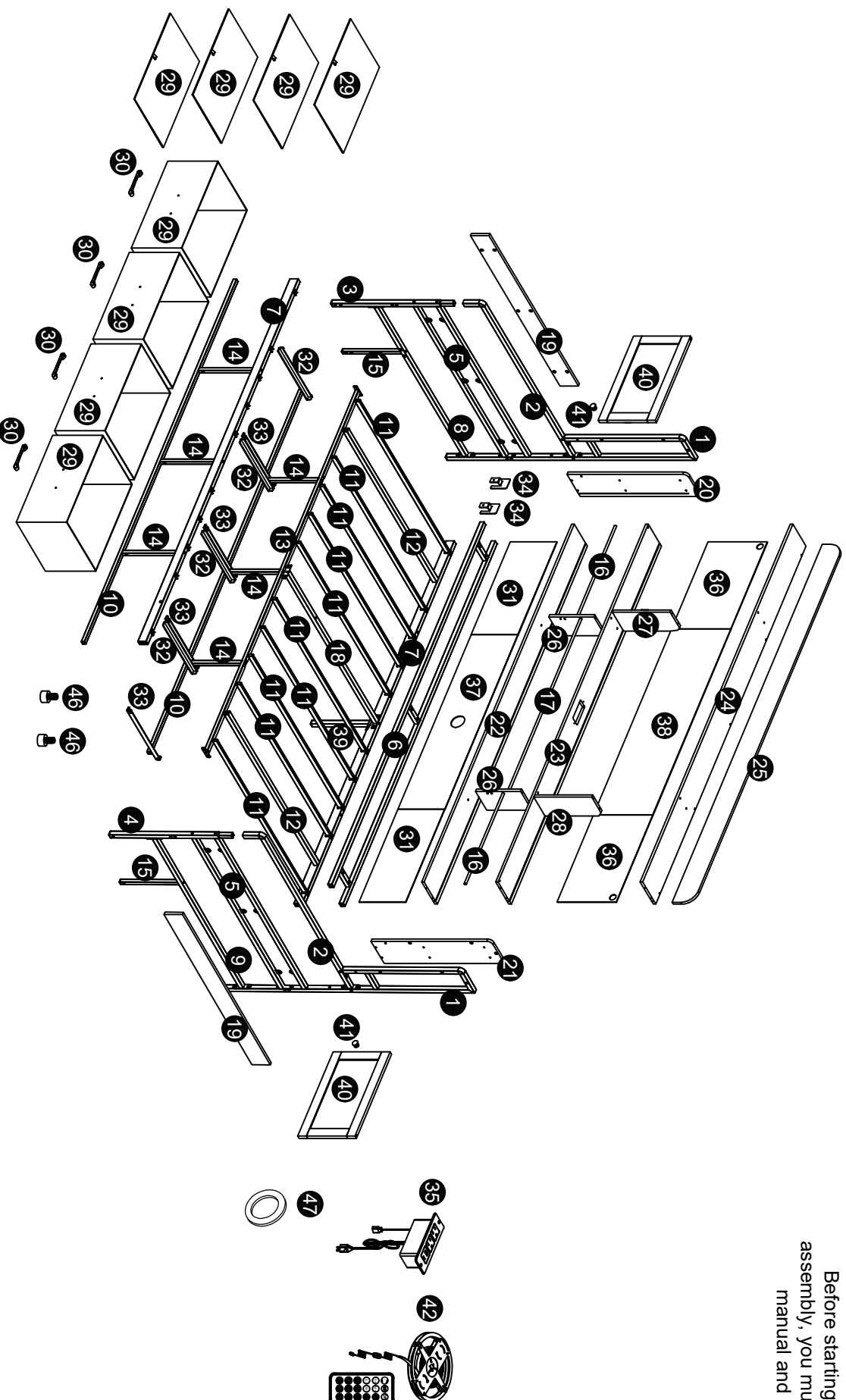

Assembly Instruction

1

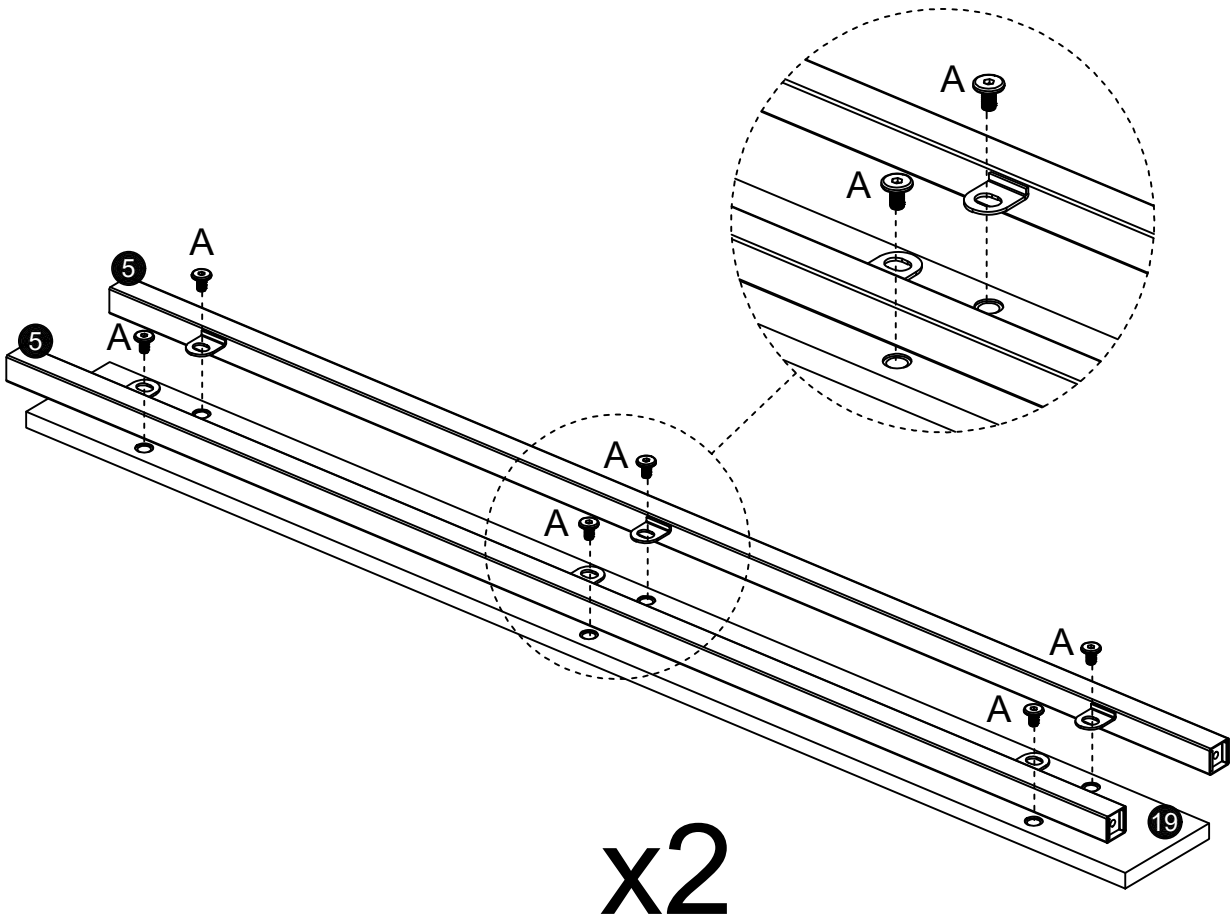

- A M6*10
x12
- N S5
x1

2

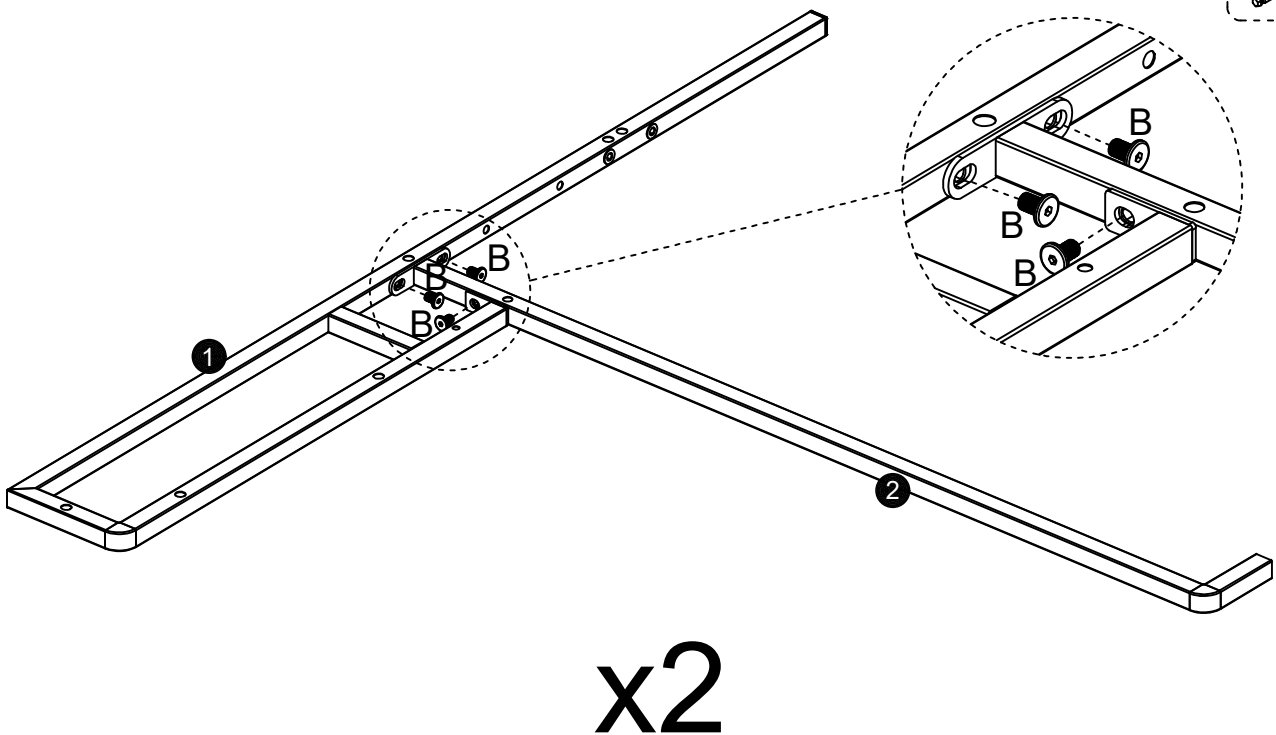

- B M8*15
x6
- N S5
x1

Assembly Instruction

3

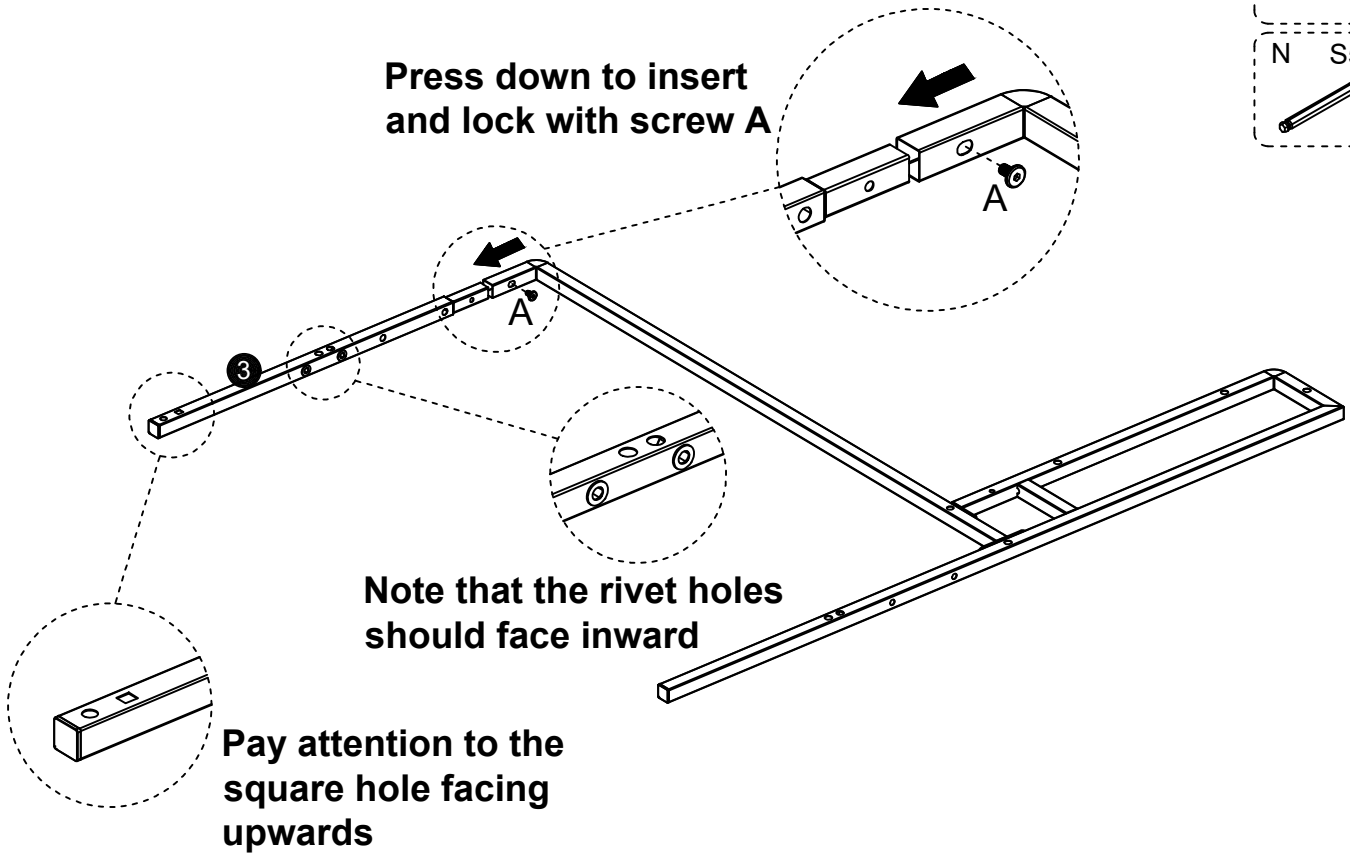
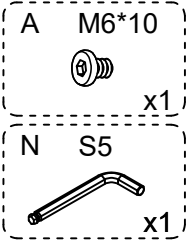

4

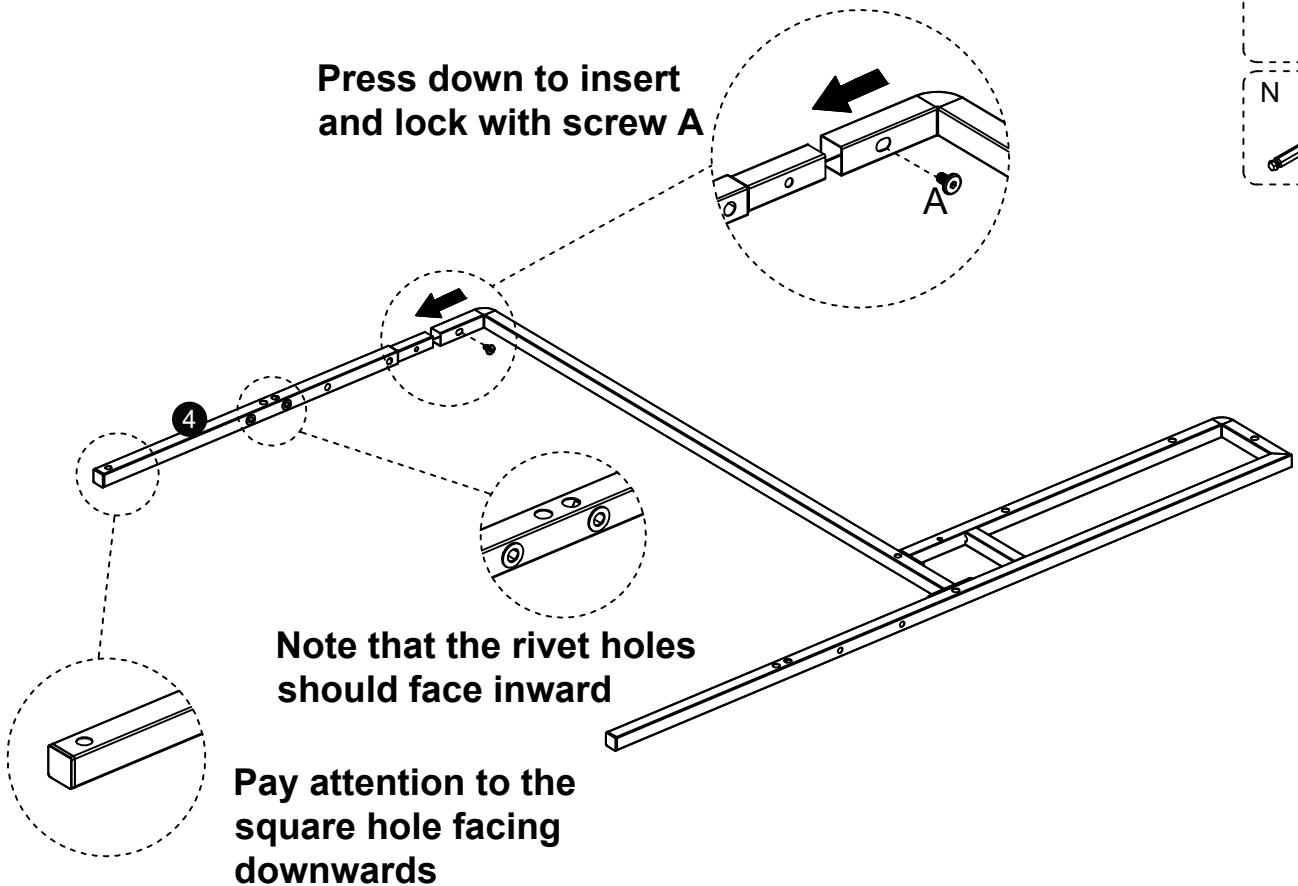
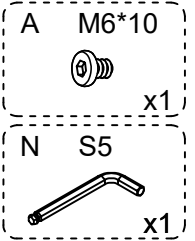

Assembly Instruction

5

Note that the rivet holes on part 8 and the screw holes on part 19 are facing in the same direction

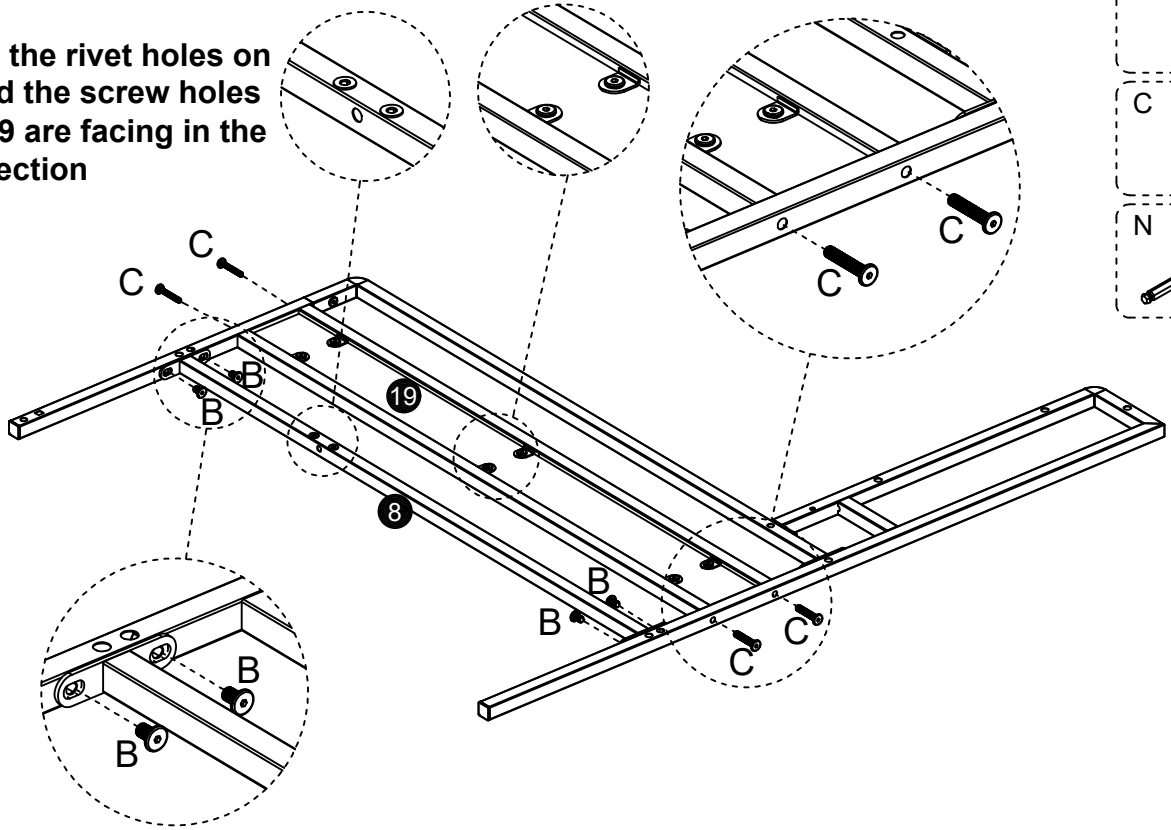

6

Note that the rivet holes on part 9 and the screw holes on part 19 are facing downwards

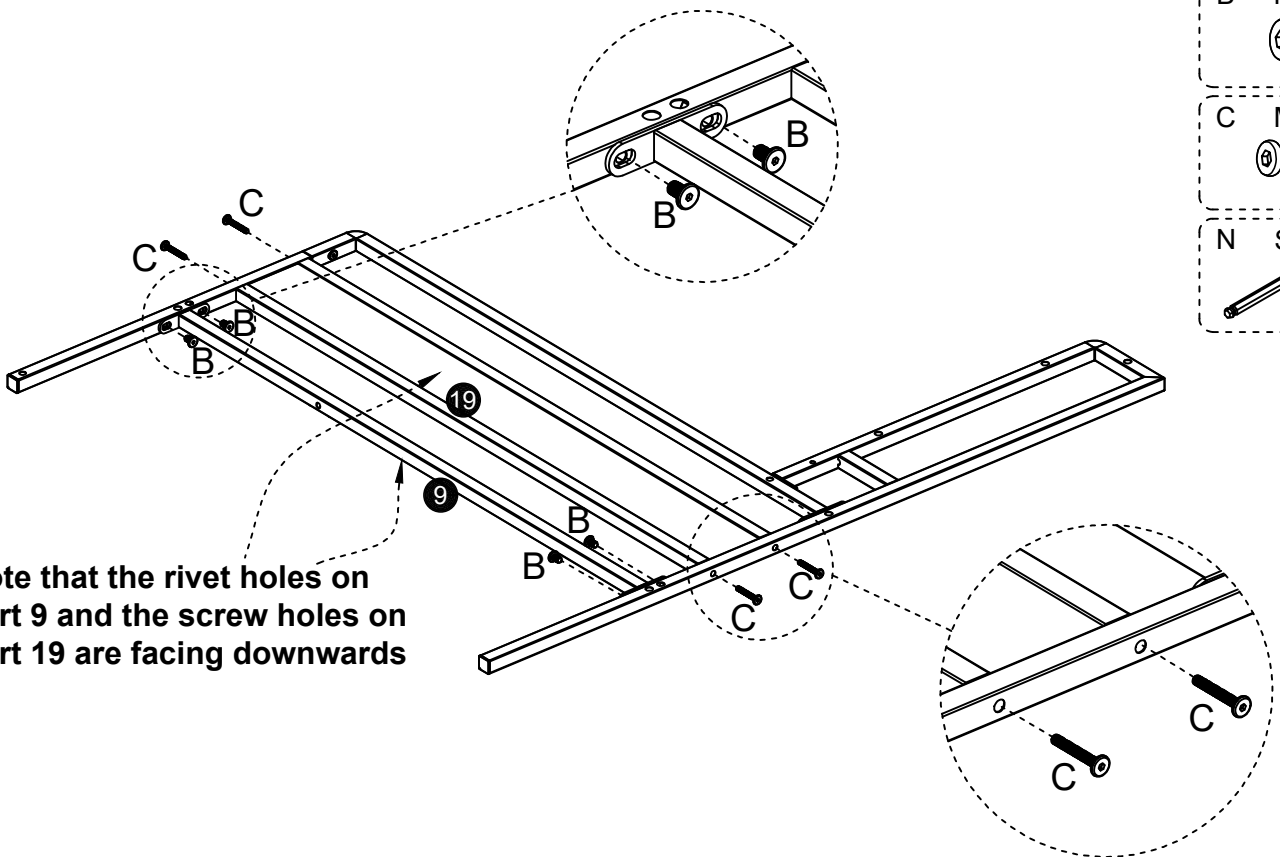

Assembly Instruction

7

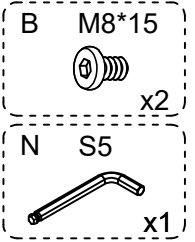
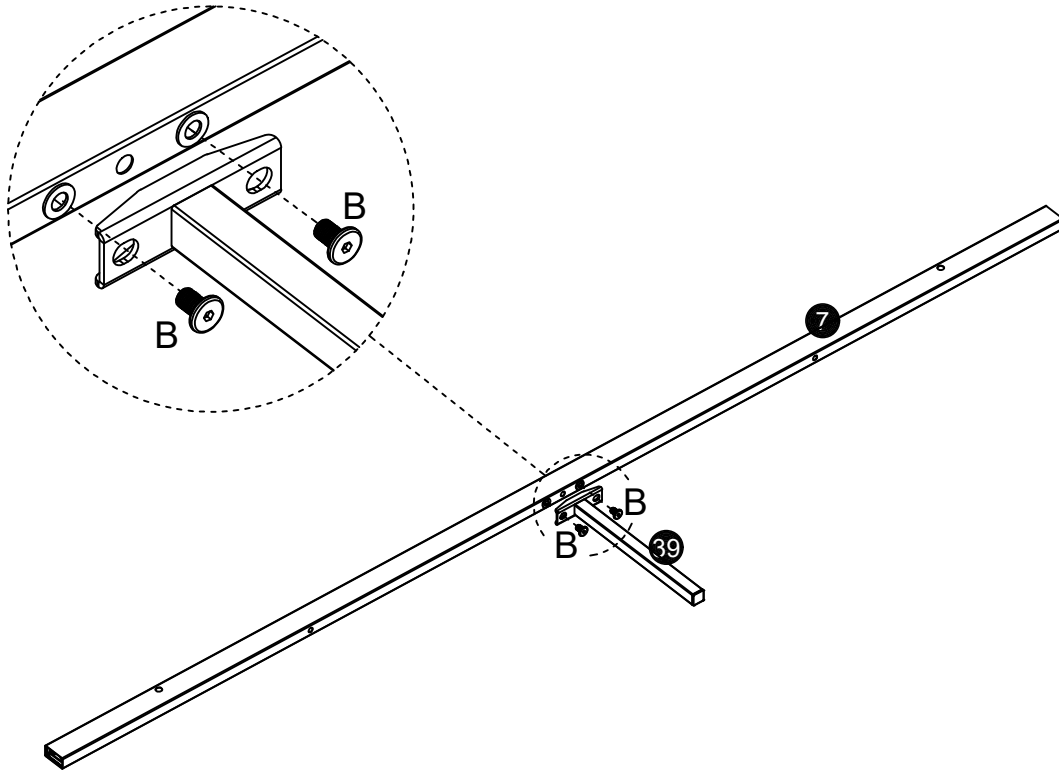

8

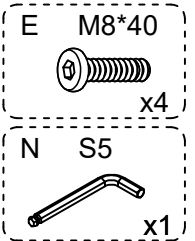
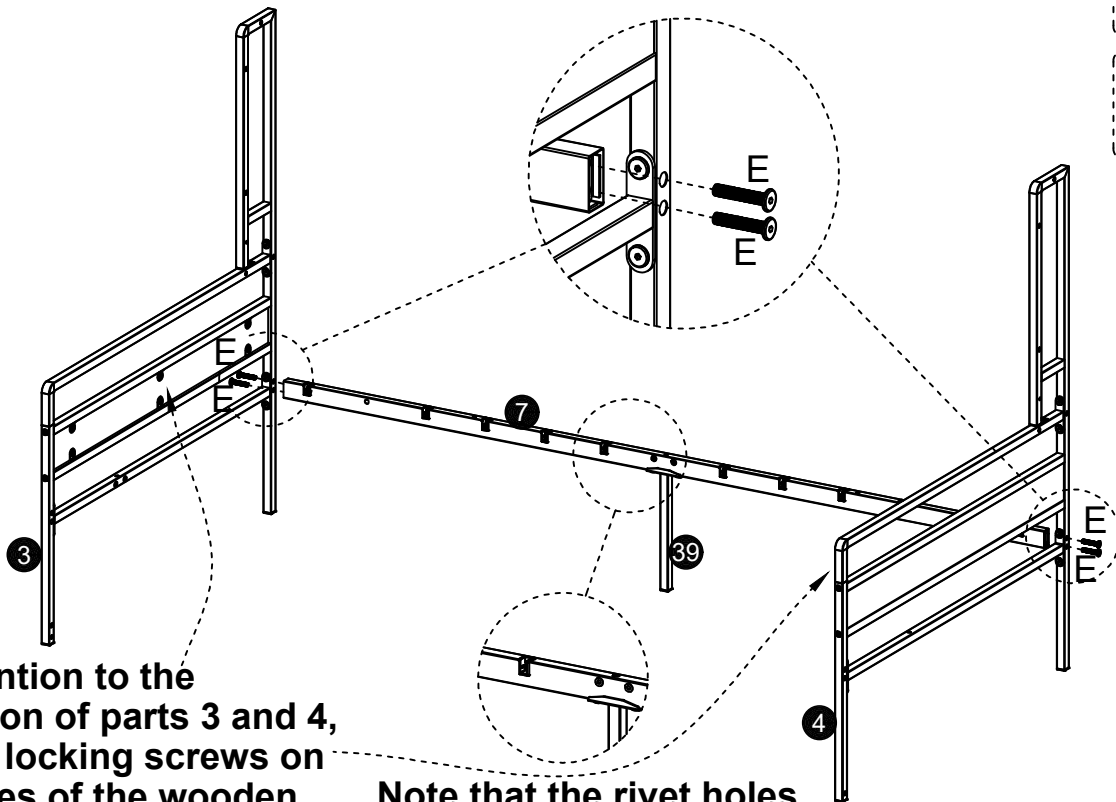

Pay attention to the orientation of parts 3 and 4, with the locking screws on both sides of the wooden board facing inward

Note that the rivet holes should face inward

Assembly Instruction

9

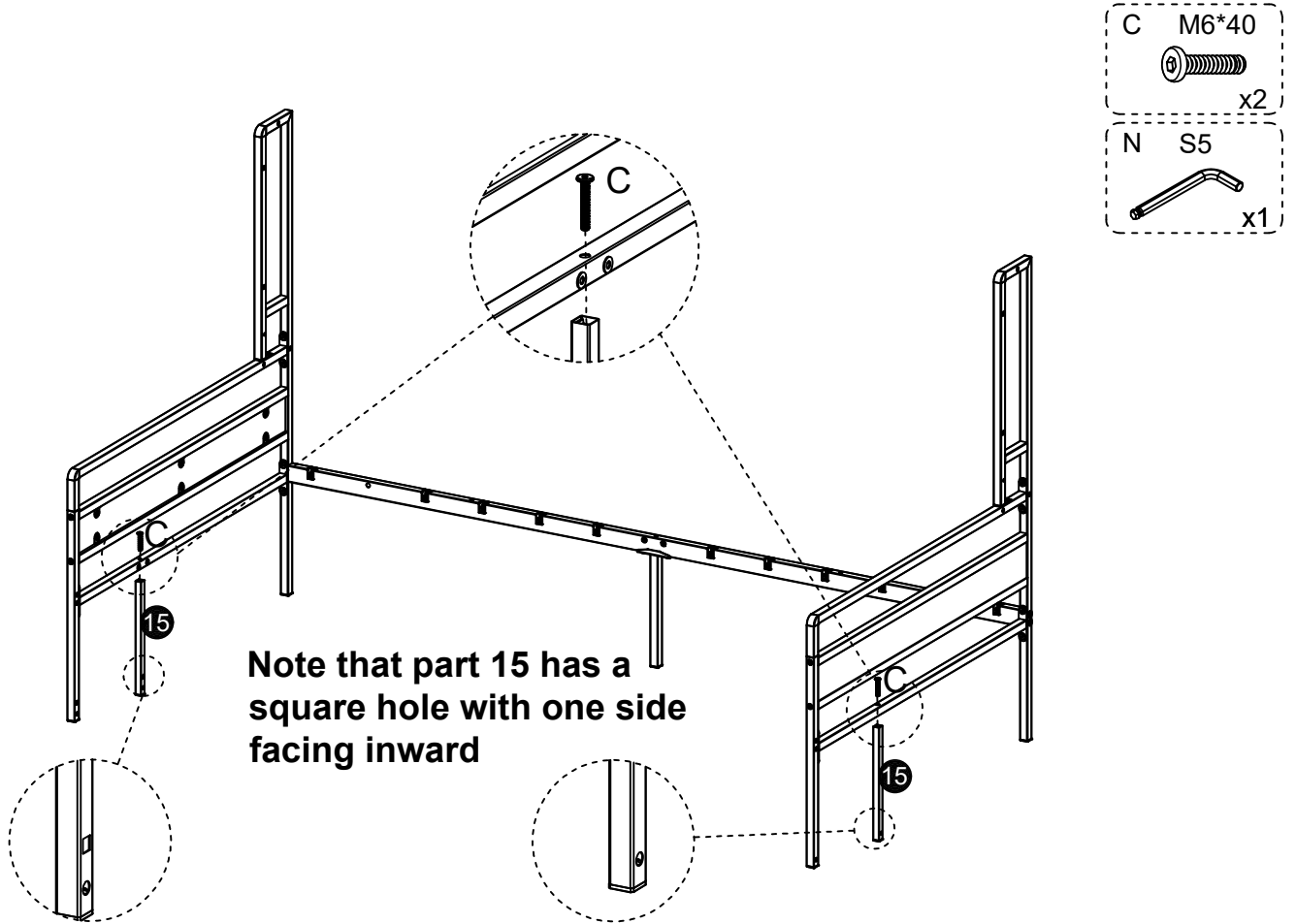

10

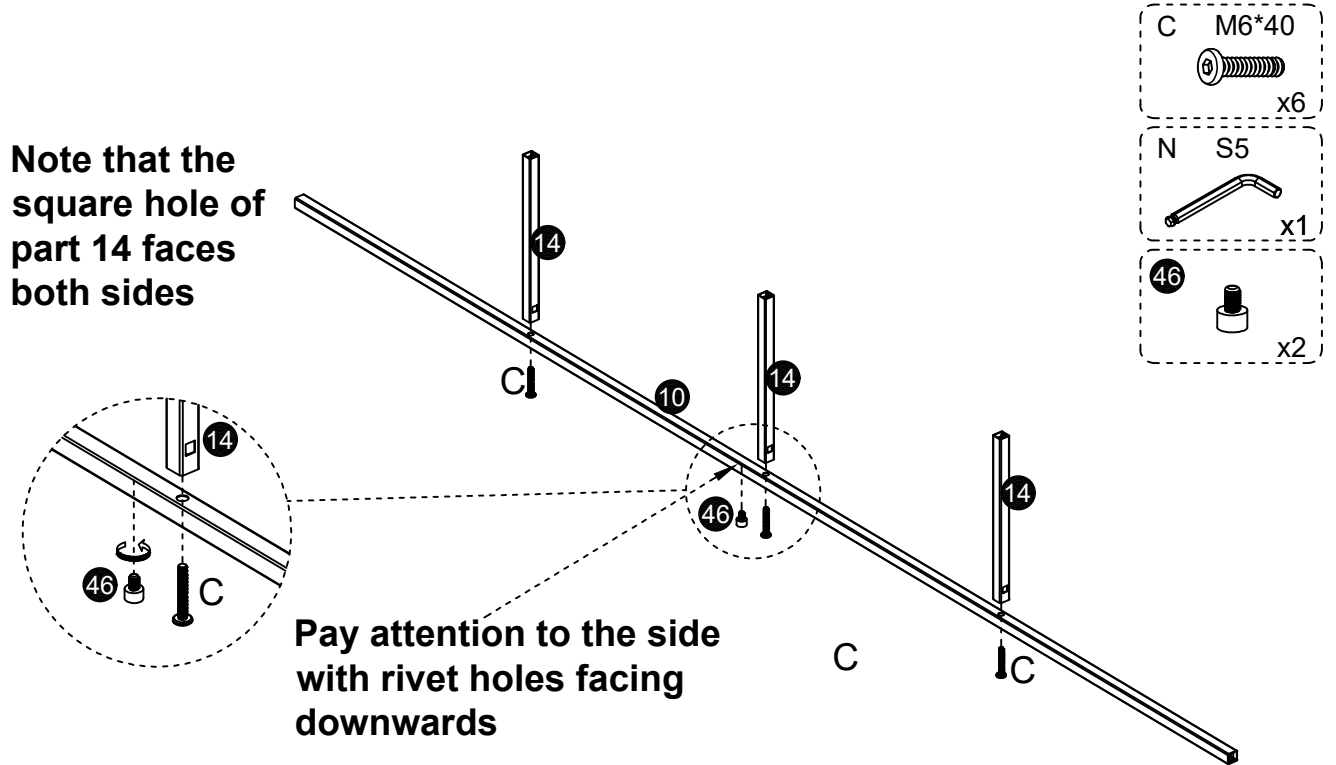

x2

Assembly Instruction

11

Note that the side with EVA is facing upwards

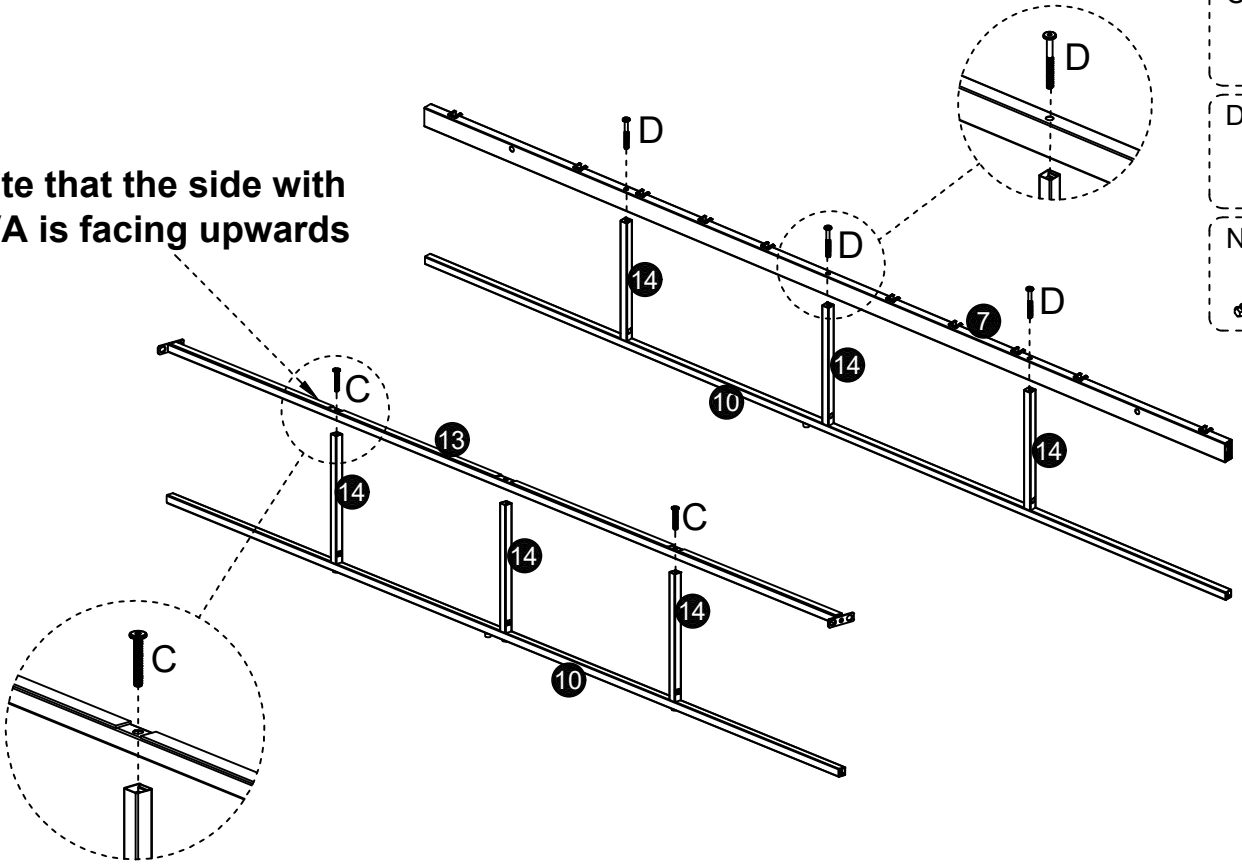

- C M6*40 x2
- D M6*60 x3
- N S5 x1

12

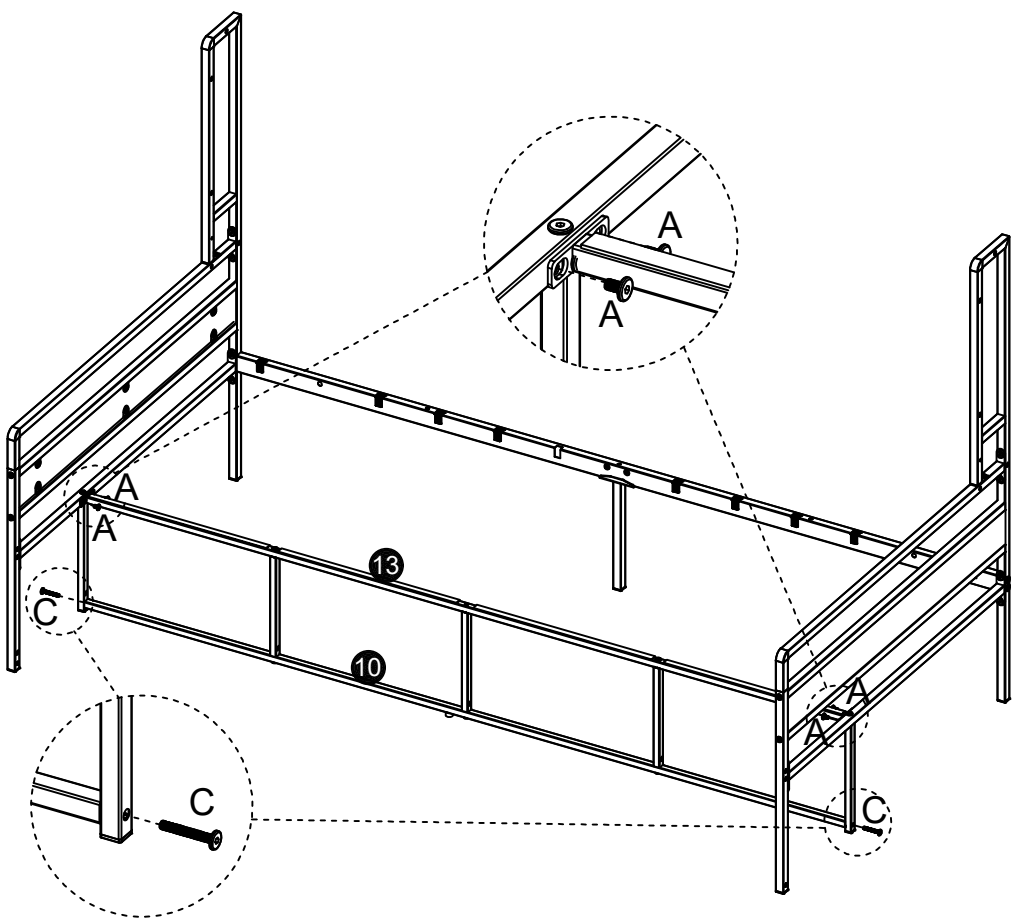

- A M6*10 x4
- C M6*40 x2
- N S5 x1

Assembly Instruction

13

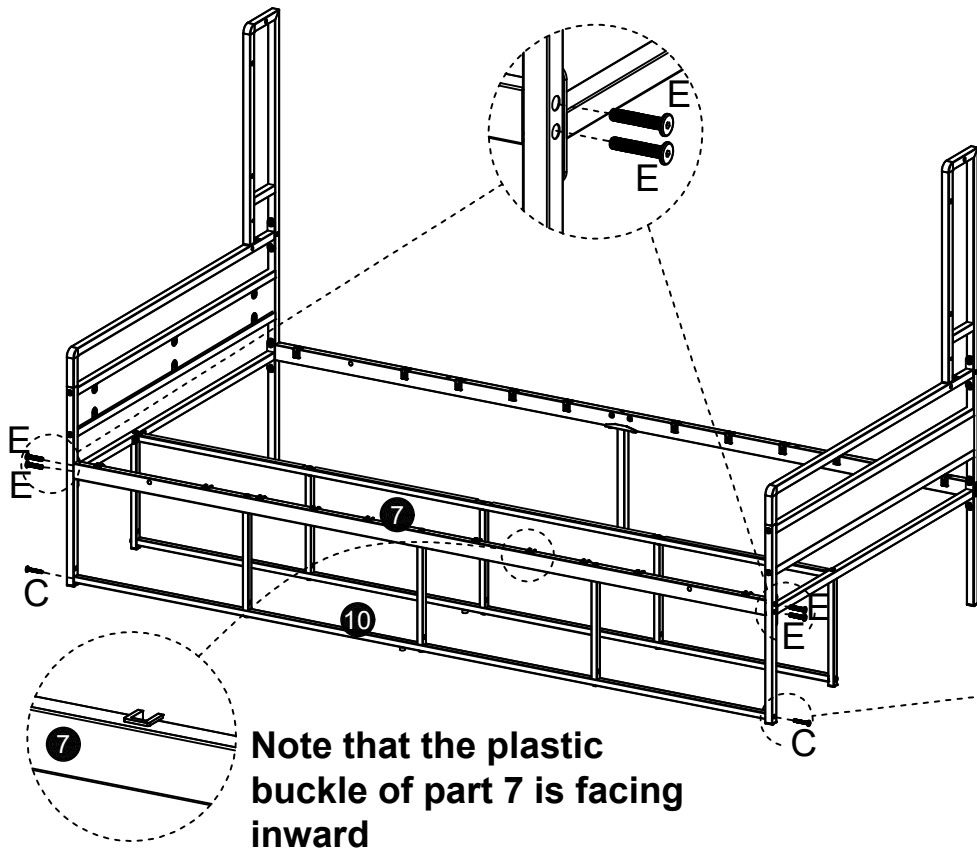

- C M6*40
x2
- E M8*40
x4
- N S5
x1

14

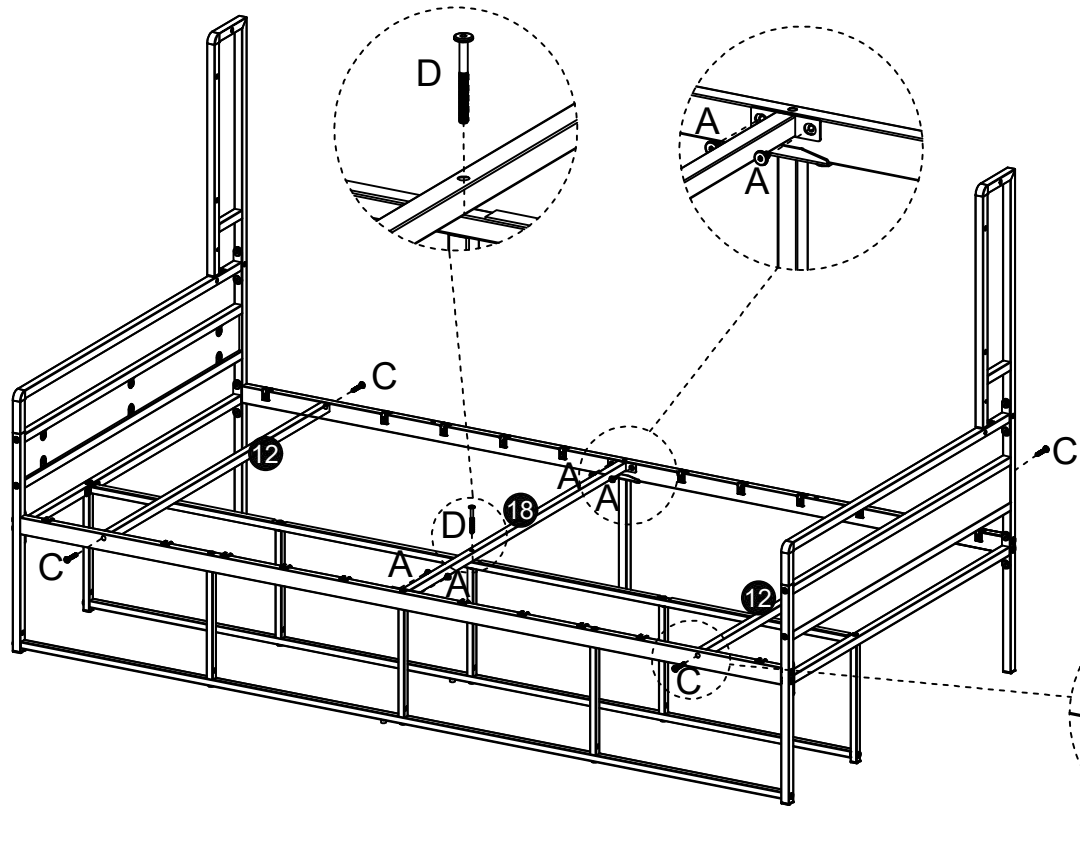



- A M6*10
x4
- C M6*40
x4
- D M6*60
x1
- N S5
x1

Assembly Instruction

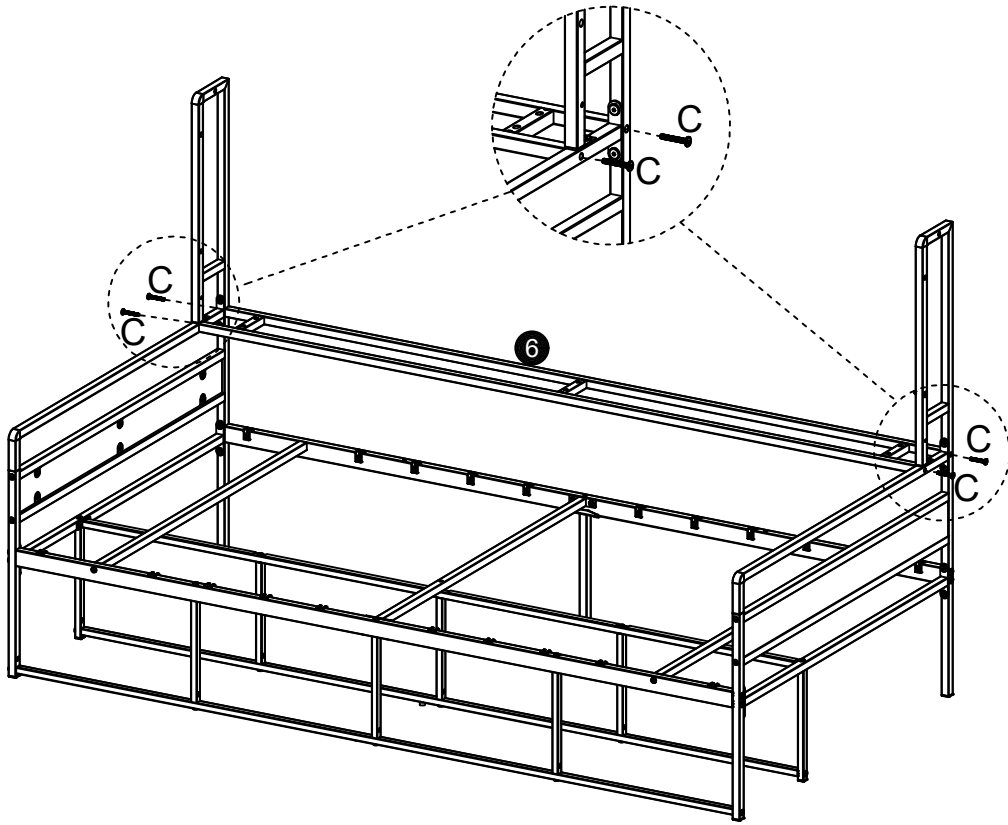
15





- C M6*40

x4
- N S5

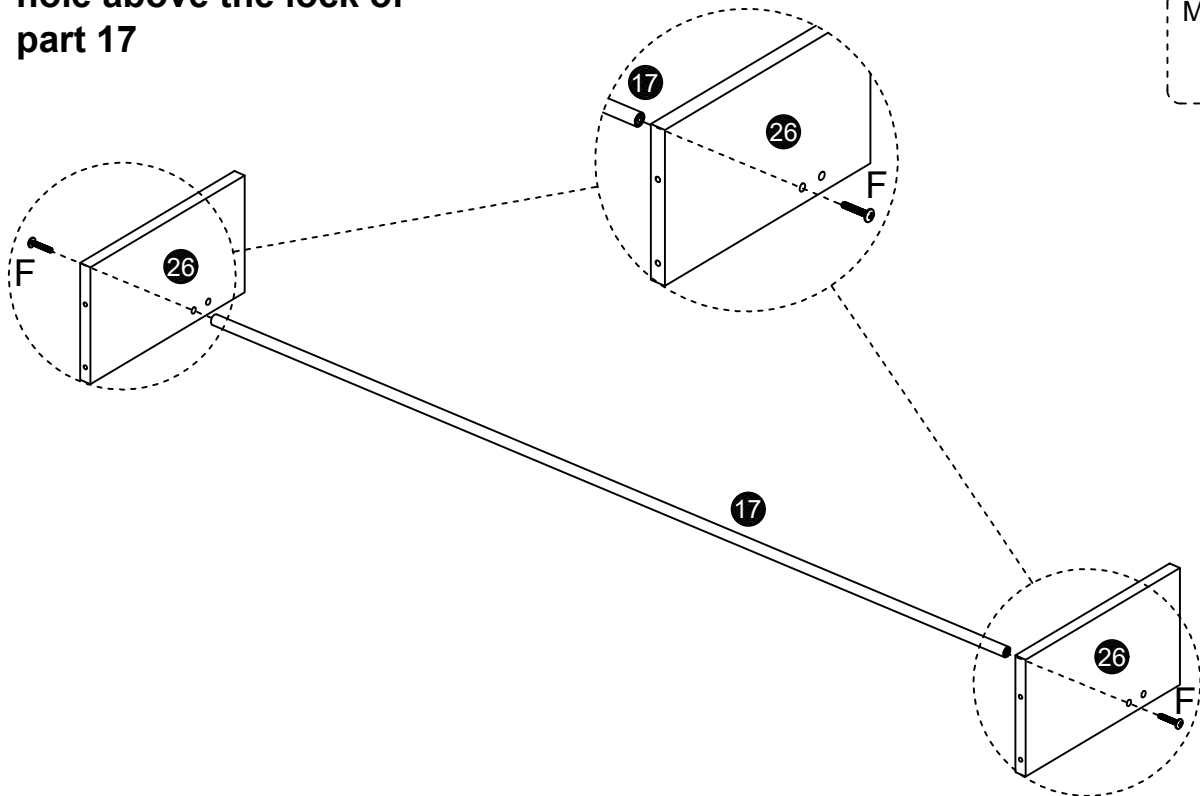
x1

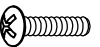
16

Pay attention to the first hole above the lock of part 17



- F M4*22

x2
- M

x1

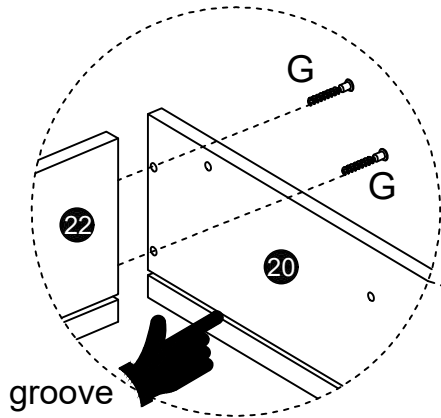
Assembly Instruction

17



groove

Note that the grooves of parts 20, 22 are facing the same direction

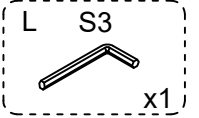
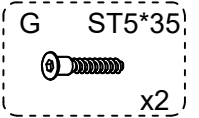
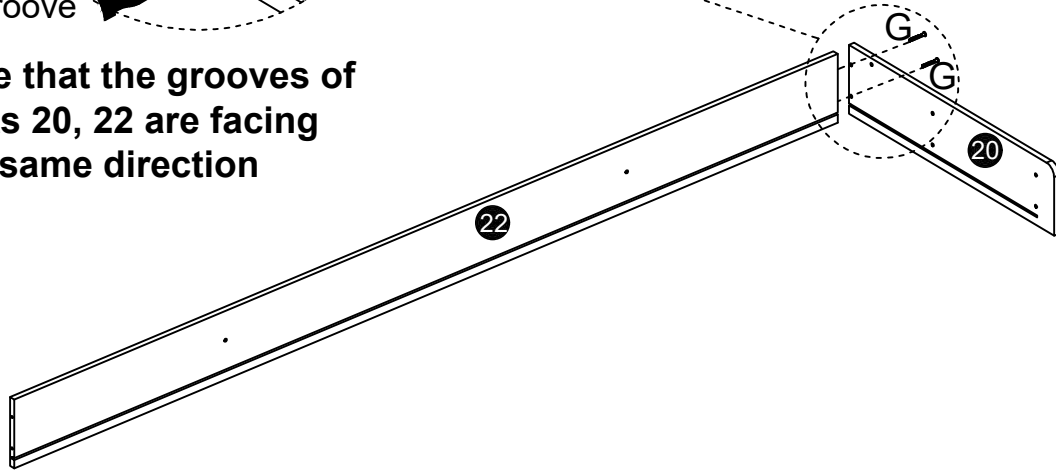

18

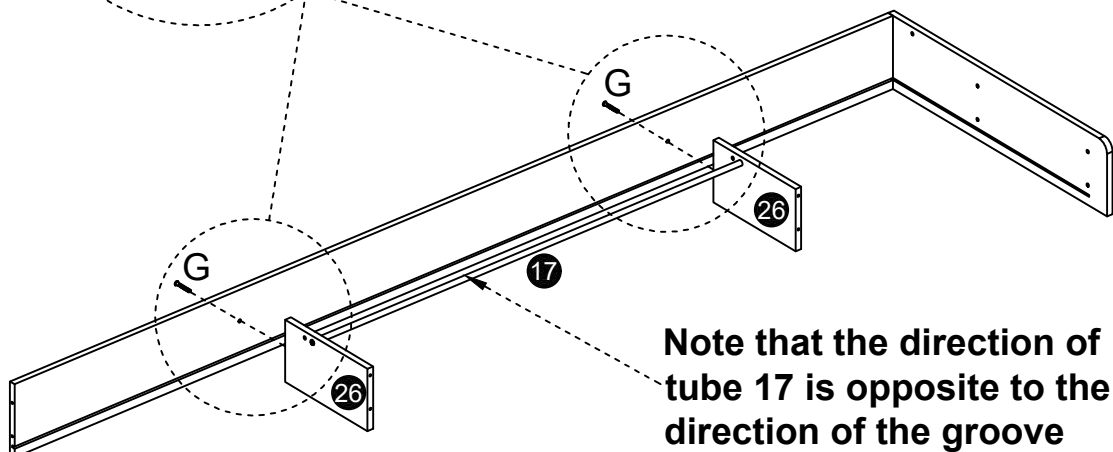
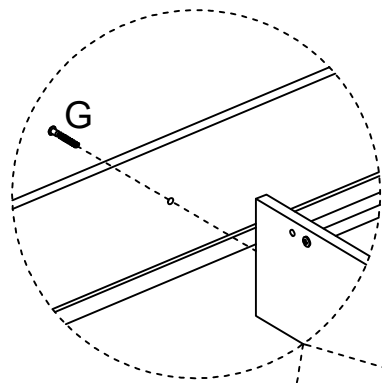

Note that the direction of tube 17 is opposite to the direction of the groove

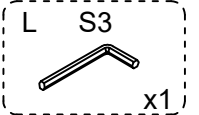
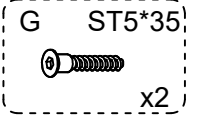

Assembly Instruction

19

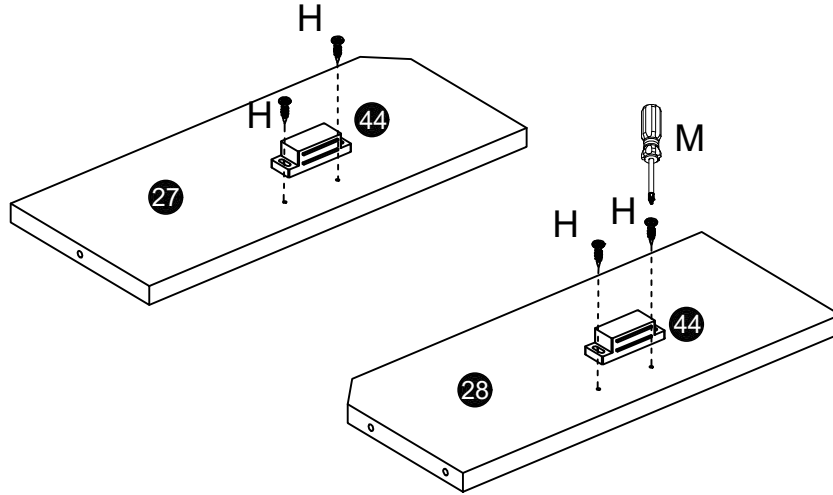

H ST3*15
x4

M
x1

44
x2

20

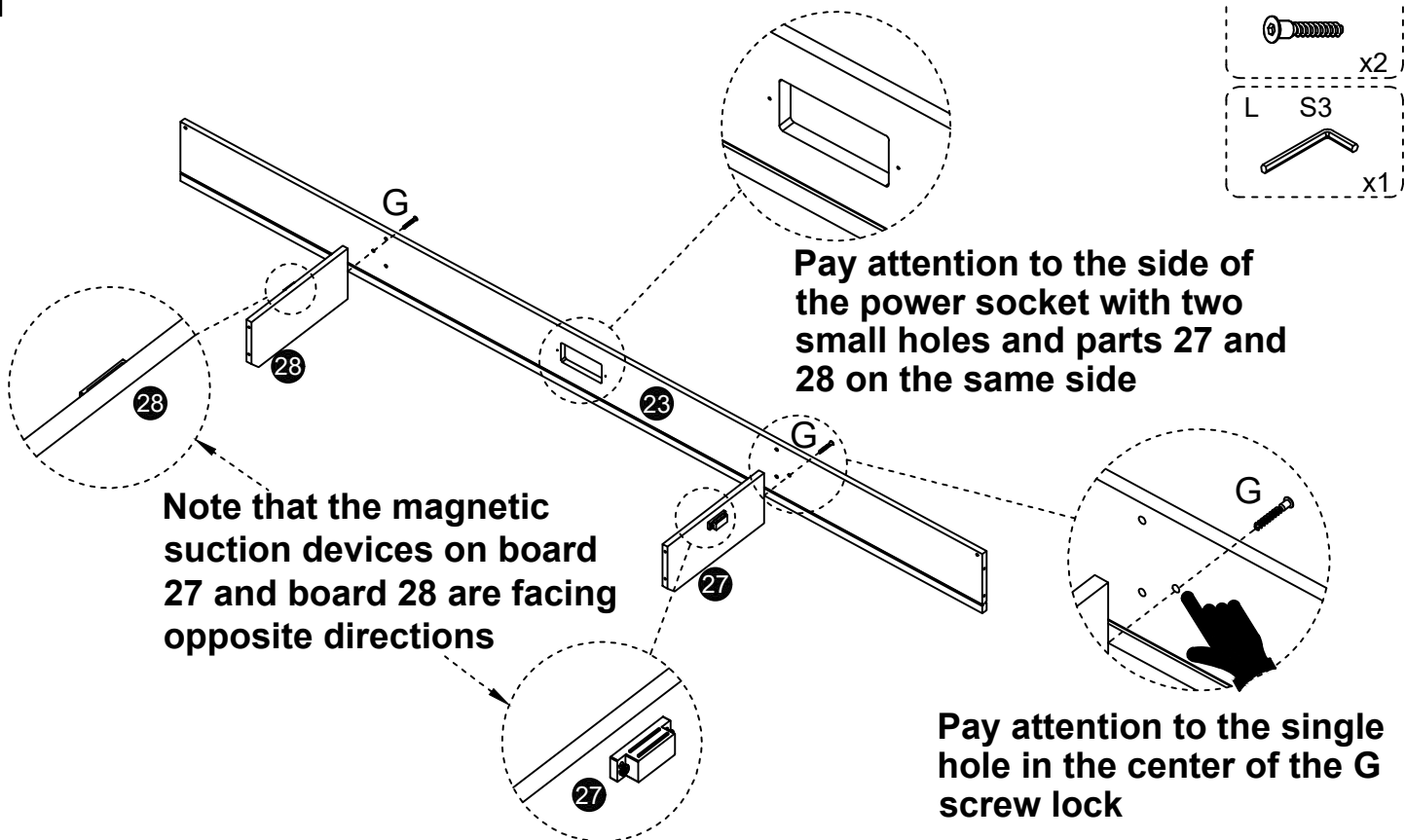

G ST5*35
x2

L S3
x1

Assembly Instruction

21

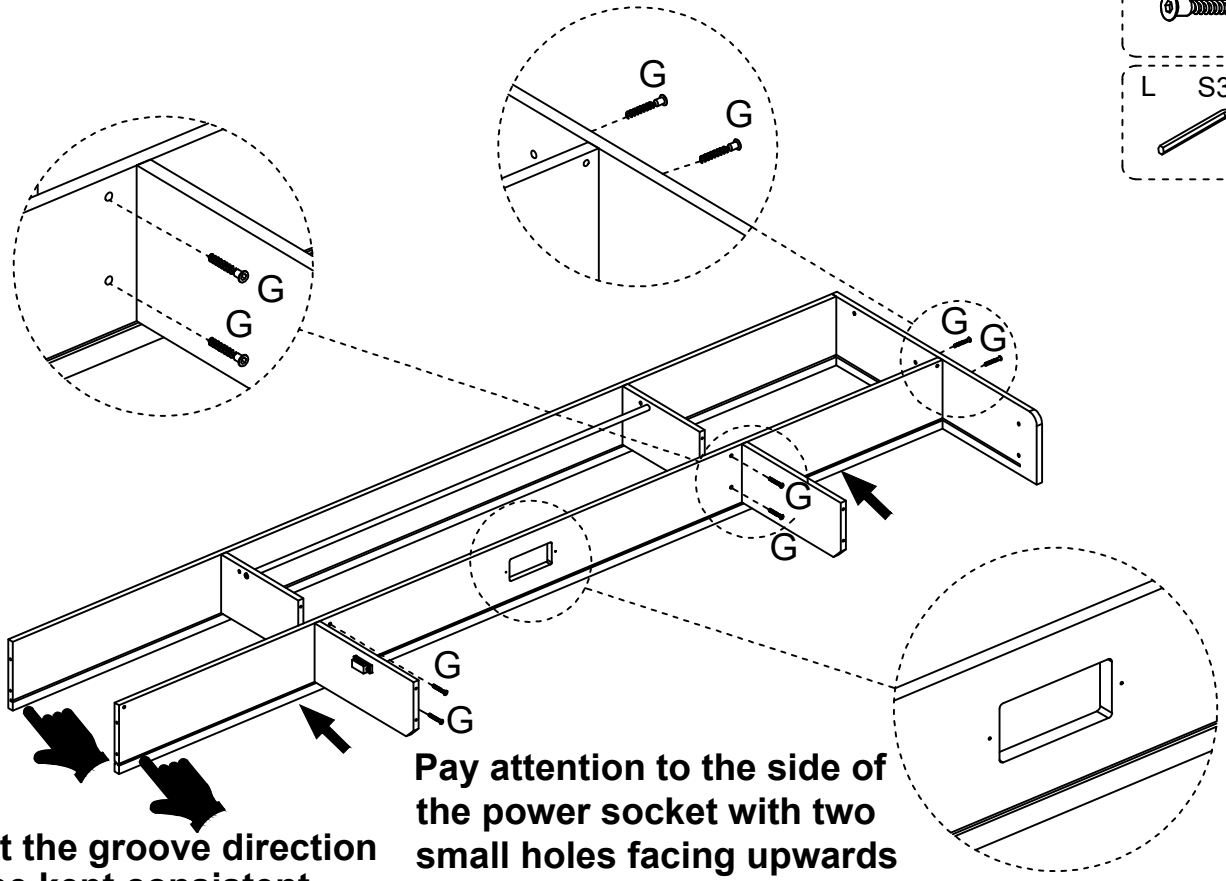

- G ST5*35 x6
- L S3 x1

22

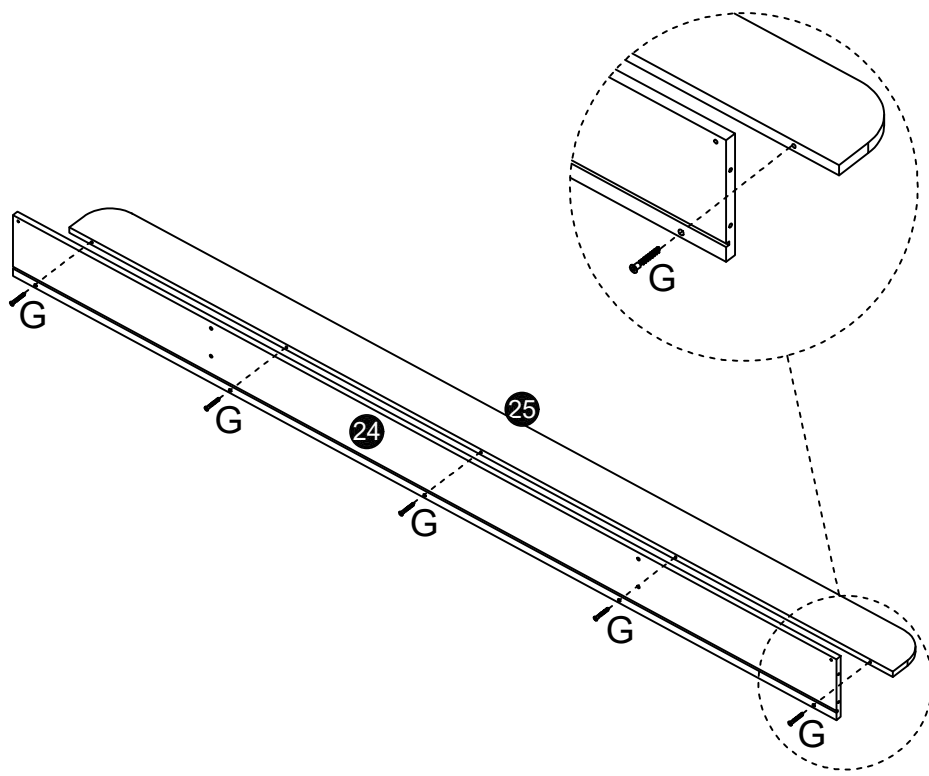

- G ST5*35 x5
- L S3 x1

Assembly Instruction

23

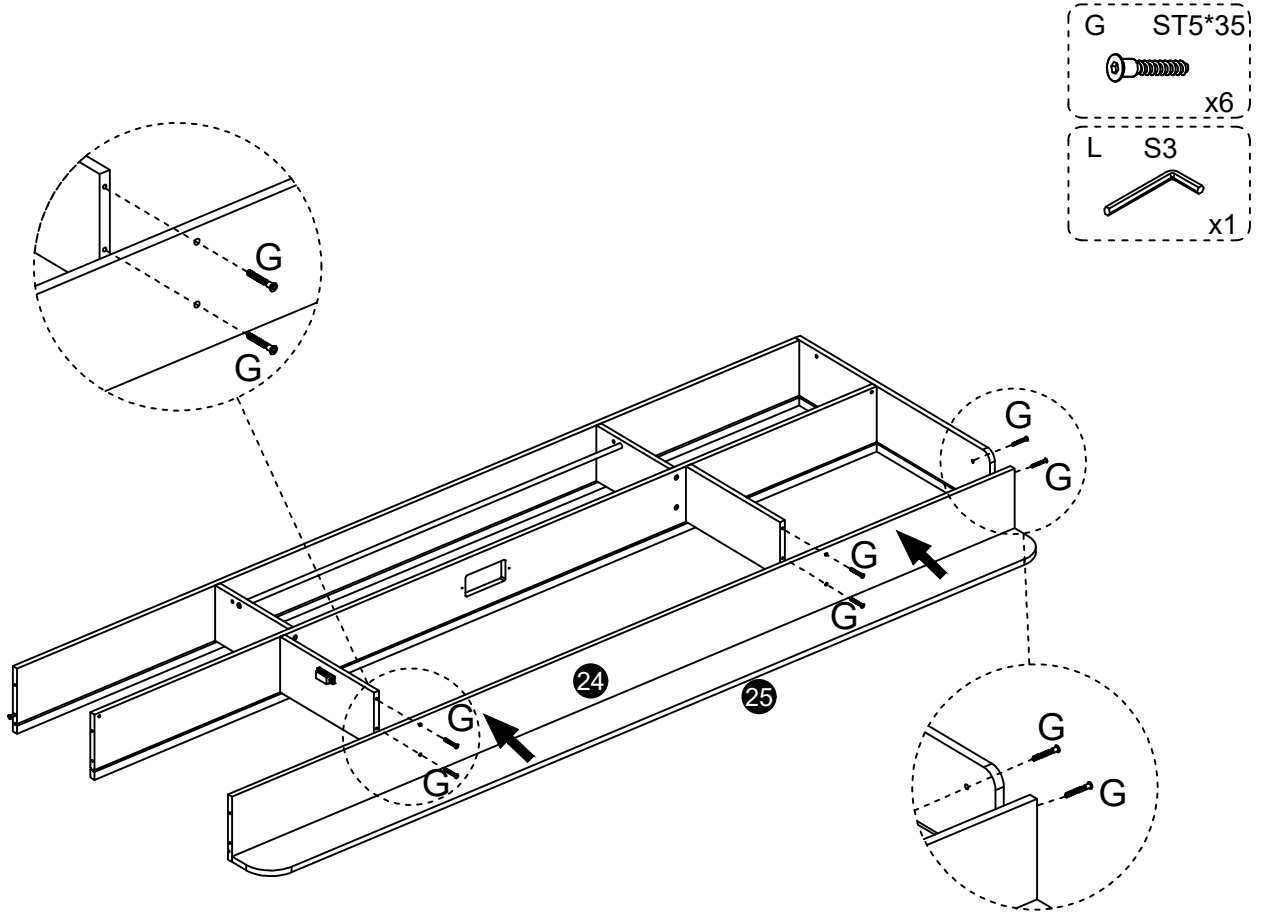

24

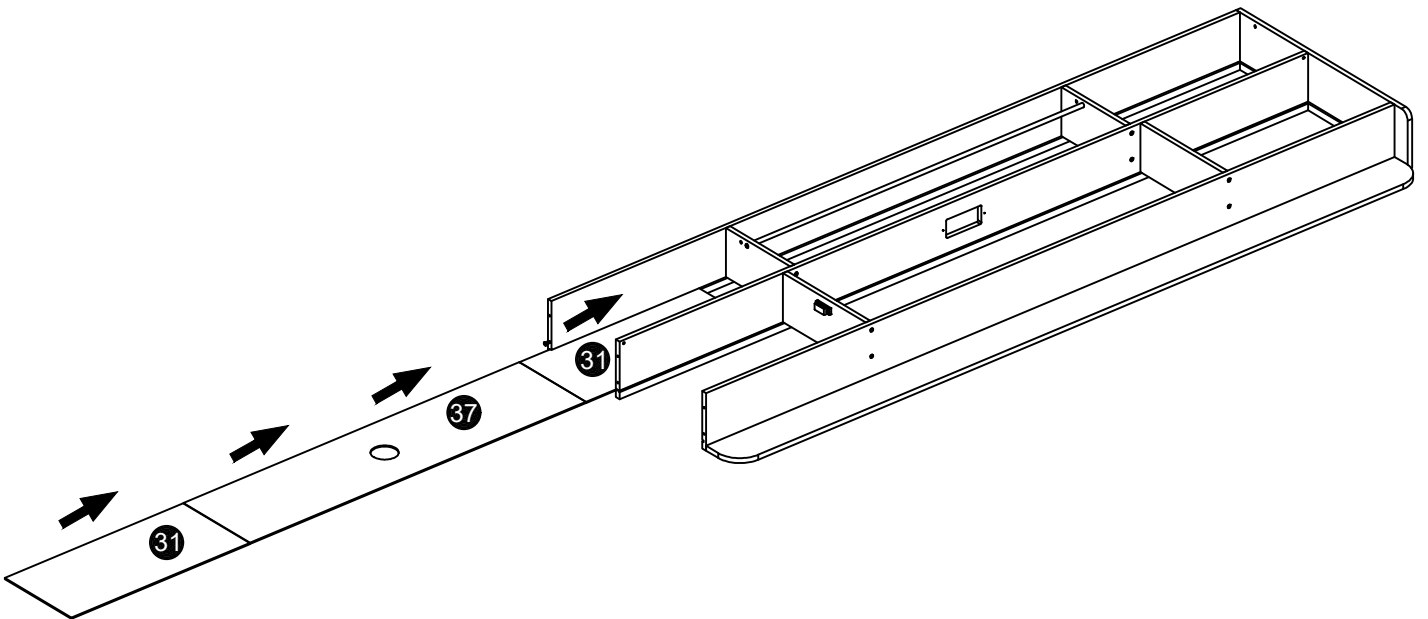

Assembly Instruction

25

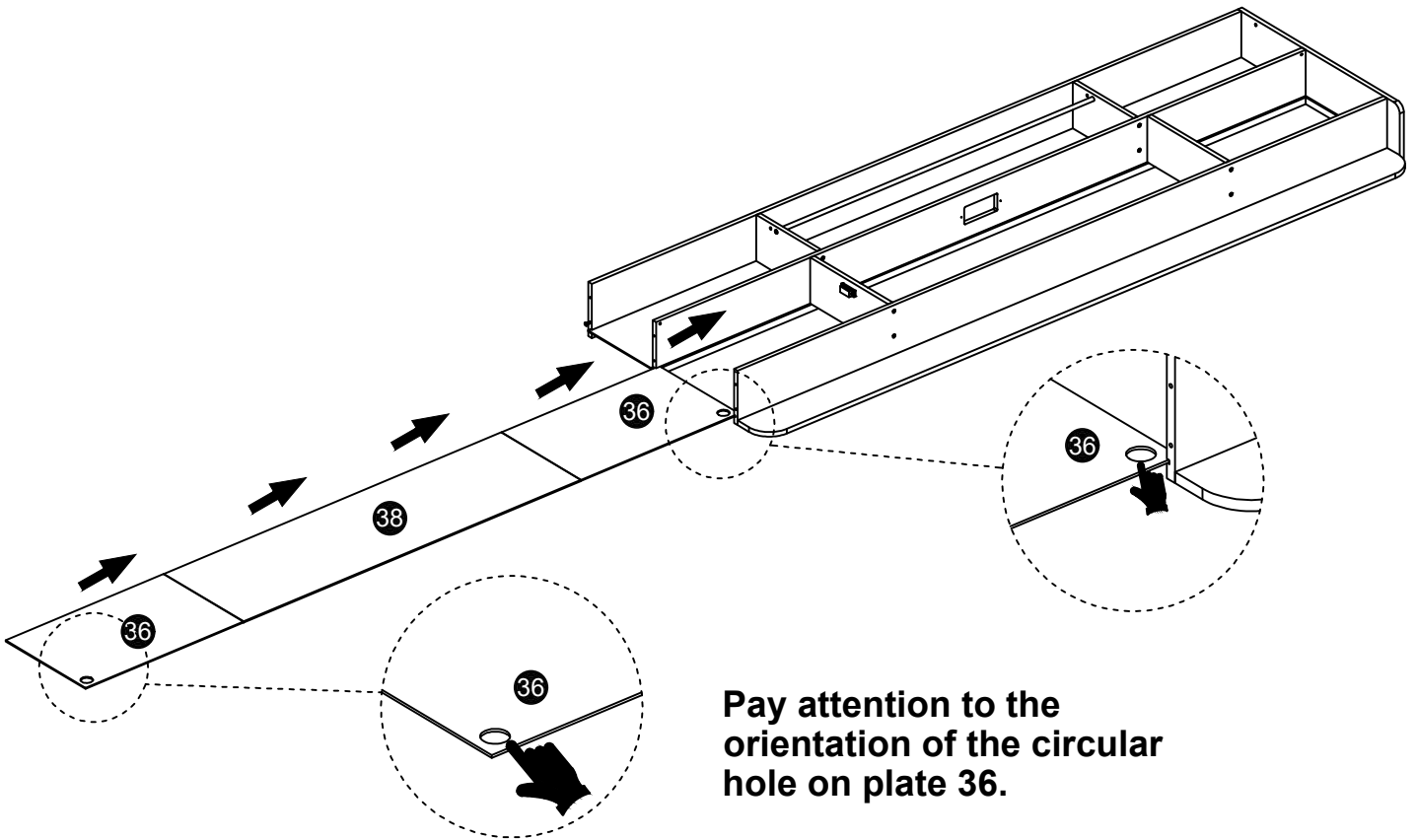

26

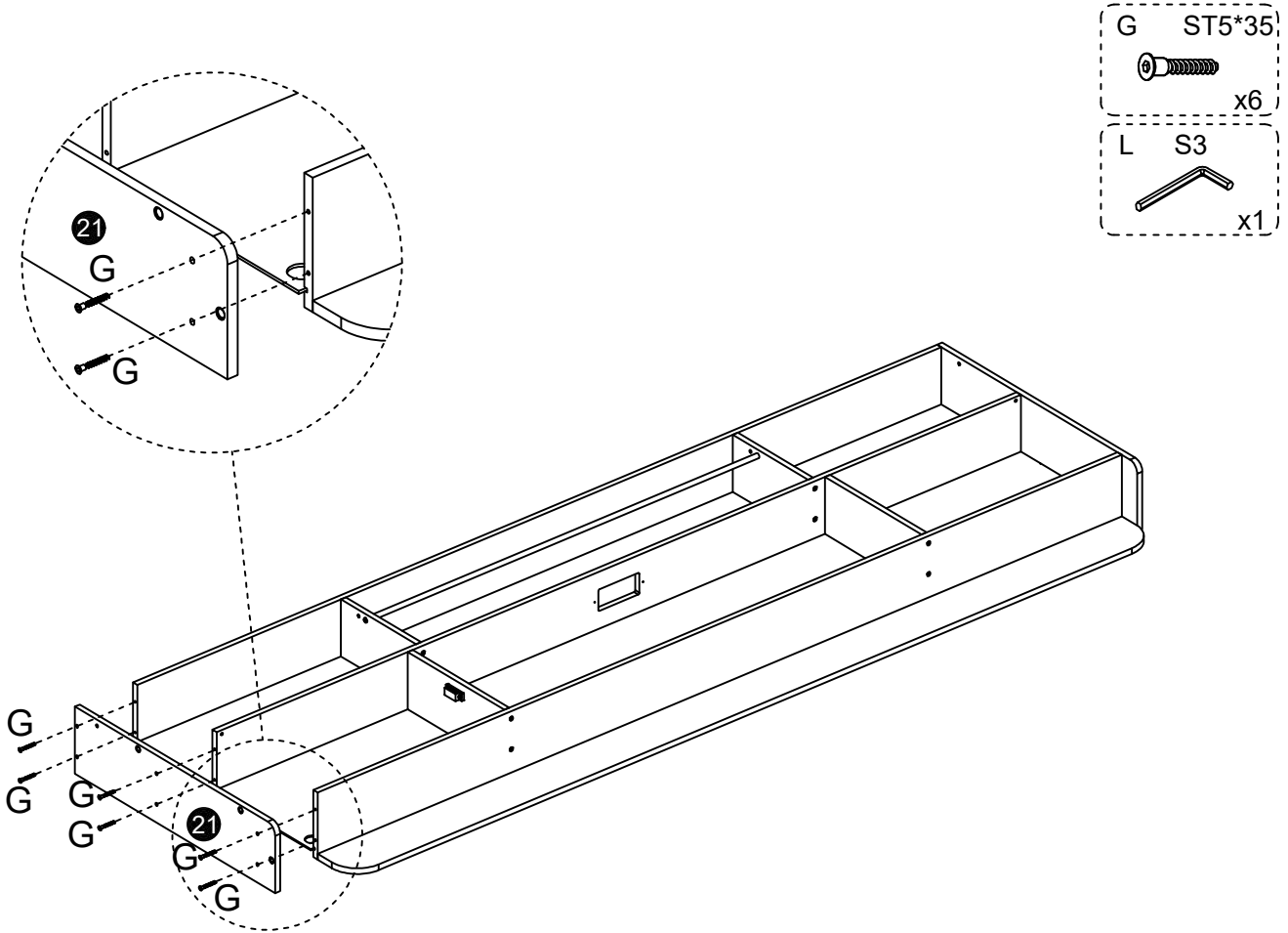

Assembly Instruction

27

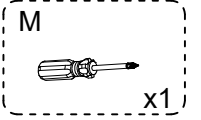
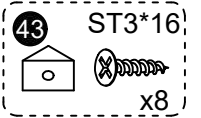
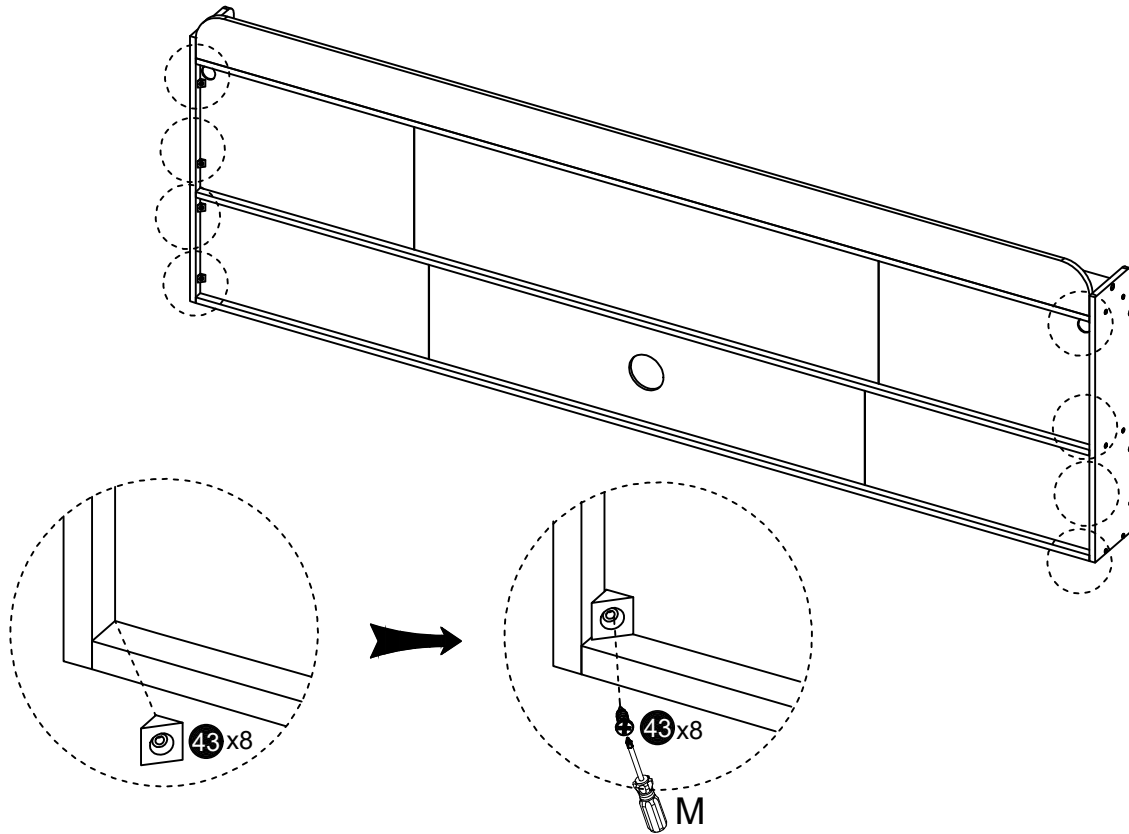

28

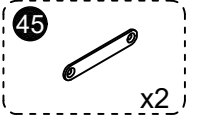
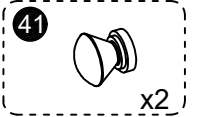
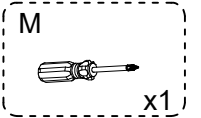
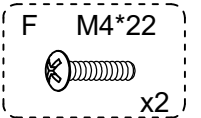
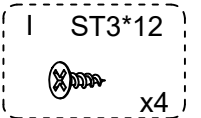
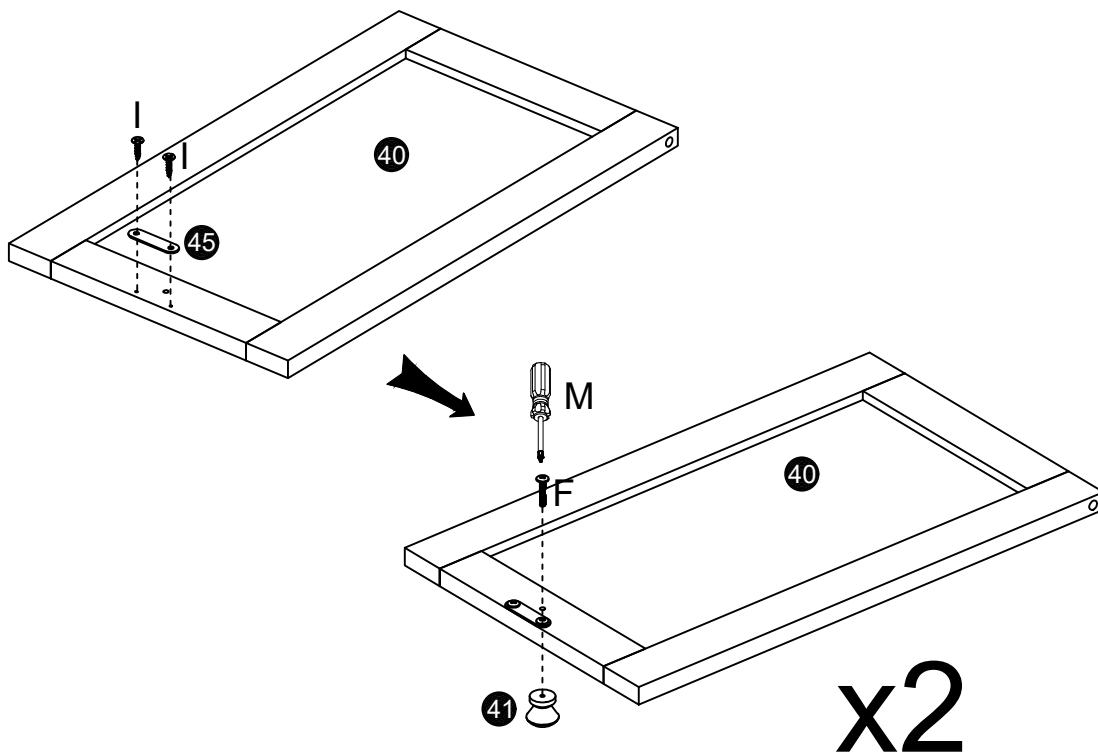

x2

Assembly Instruction

29

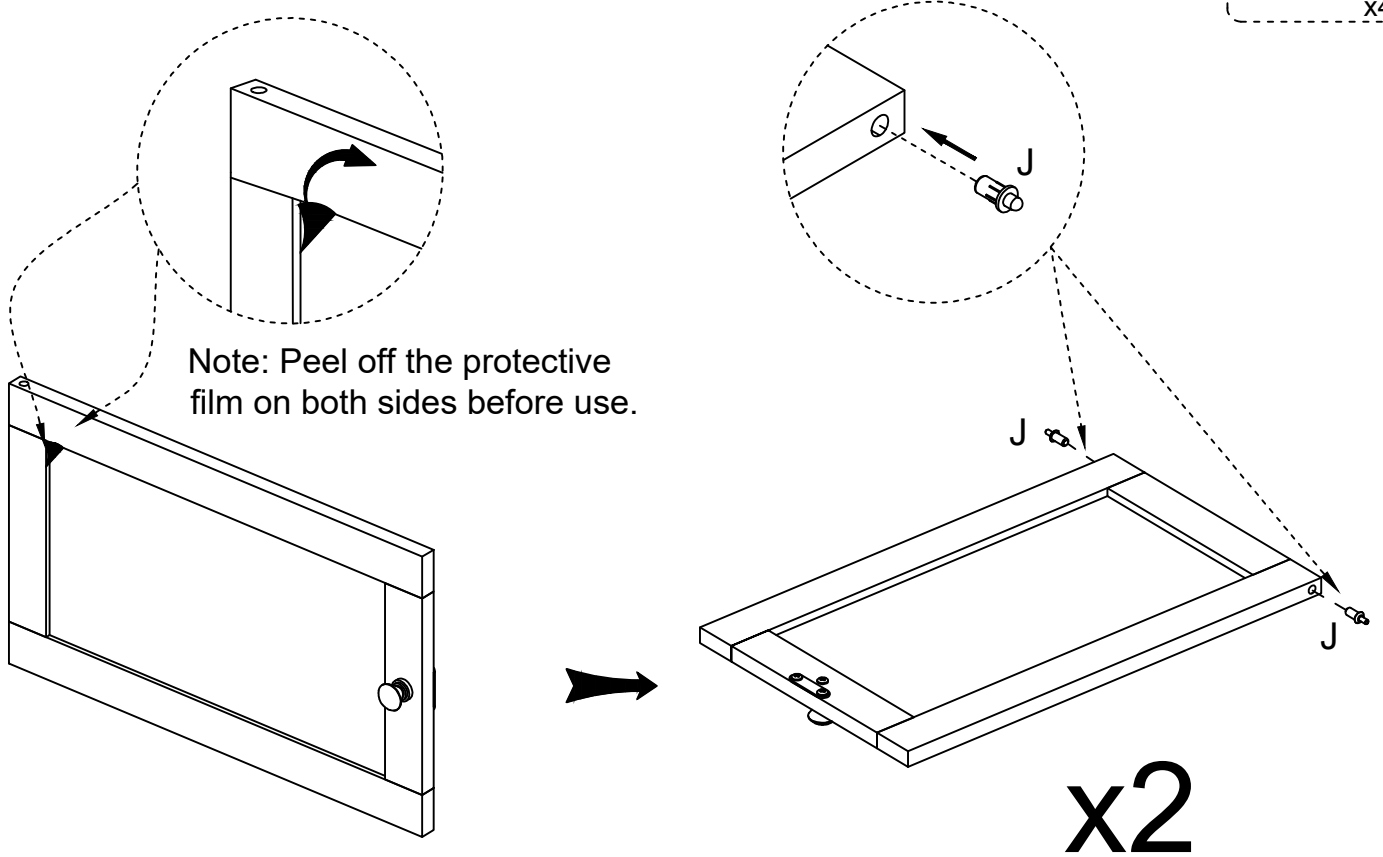
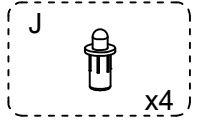

30

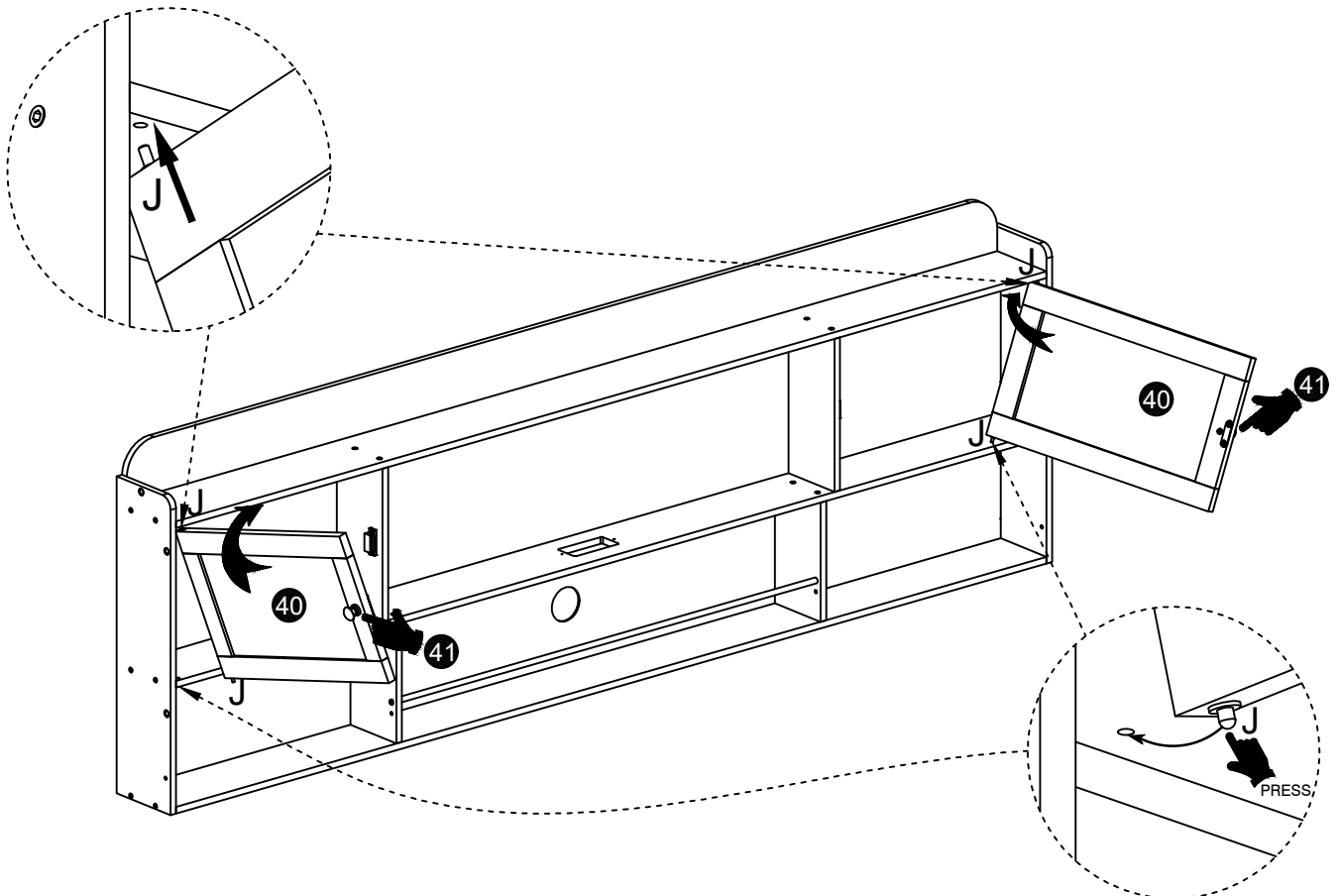

Assembly Instruction

31

NO.1 Open accessory(47)
NO.2 Place them separately on
the front and back of the(37)
hole and oress them tightly

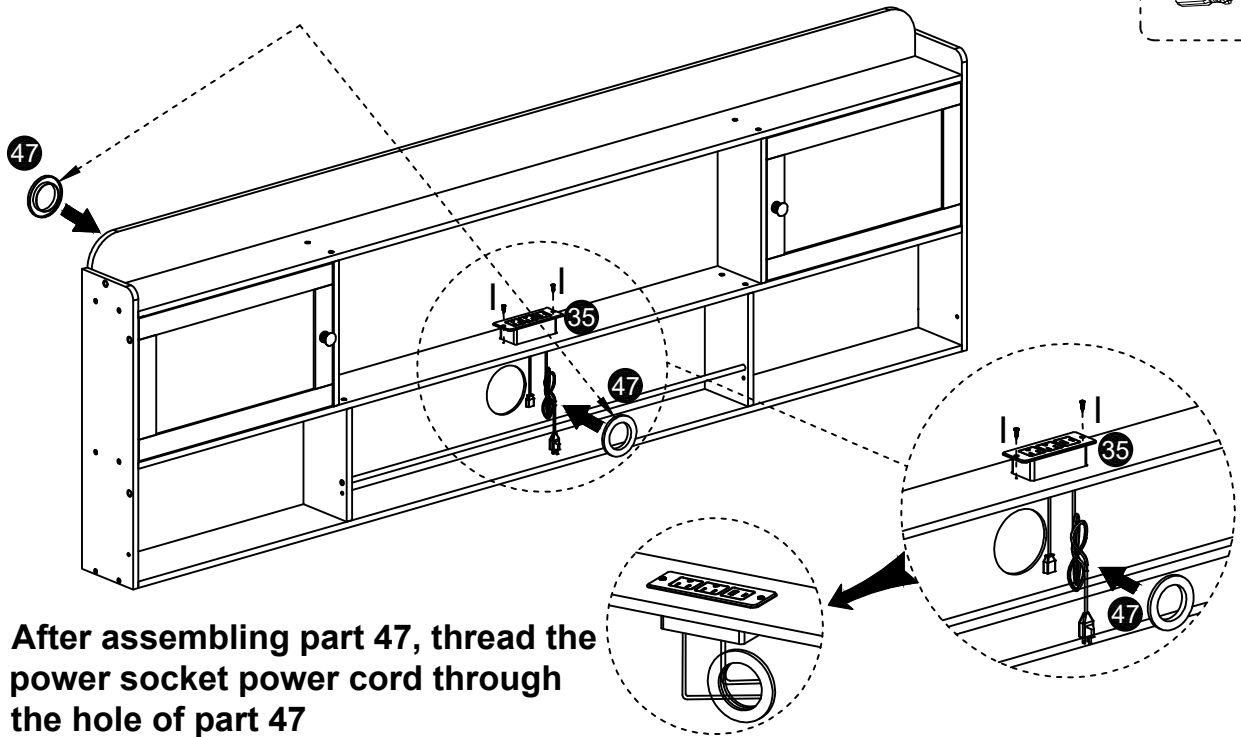
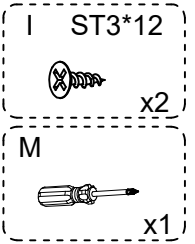

After assembling part 47, thread the
power socket power cord
through
the hole of part 47

32

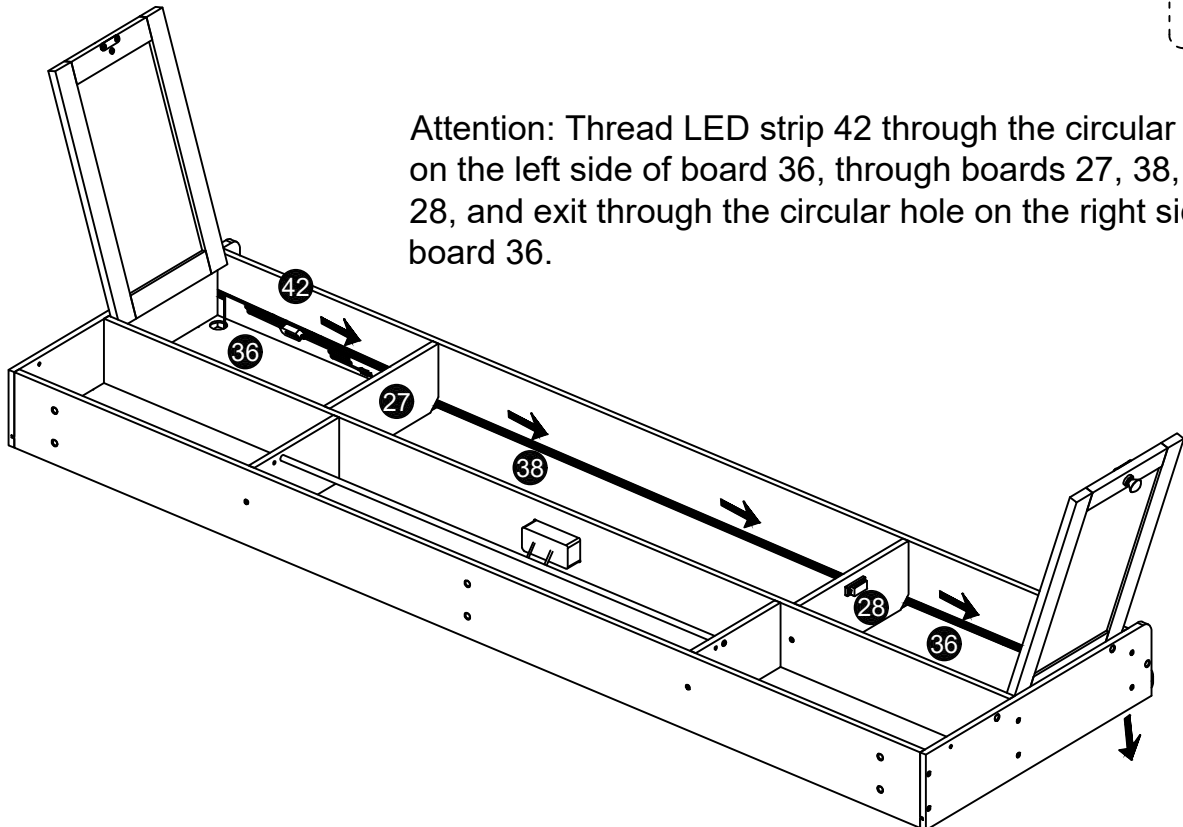
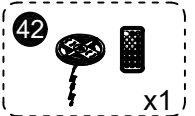

Attention: Thread LED strip 42 through the circular hole
on the left side of board 36, through boards 27, 38, and
28, and exit through the circular hole on the right side of
board 36.

Assembly Instruction

33

Loosen C screws on both sides by 50%.

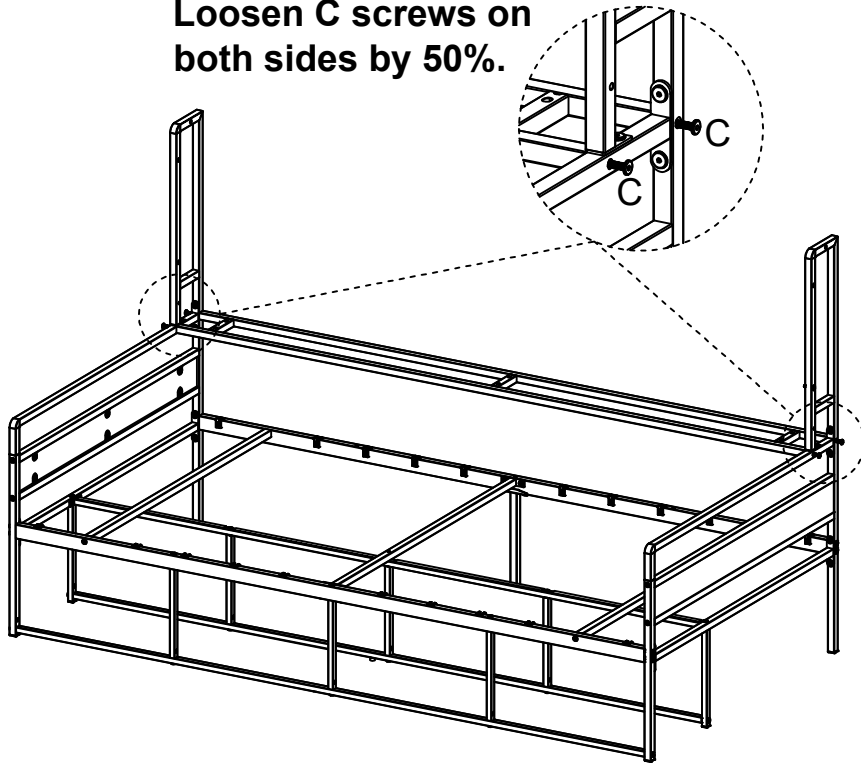

34

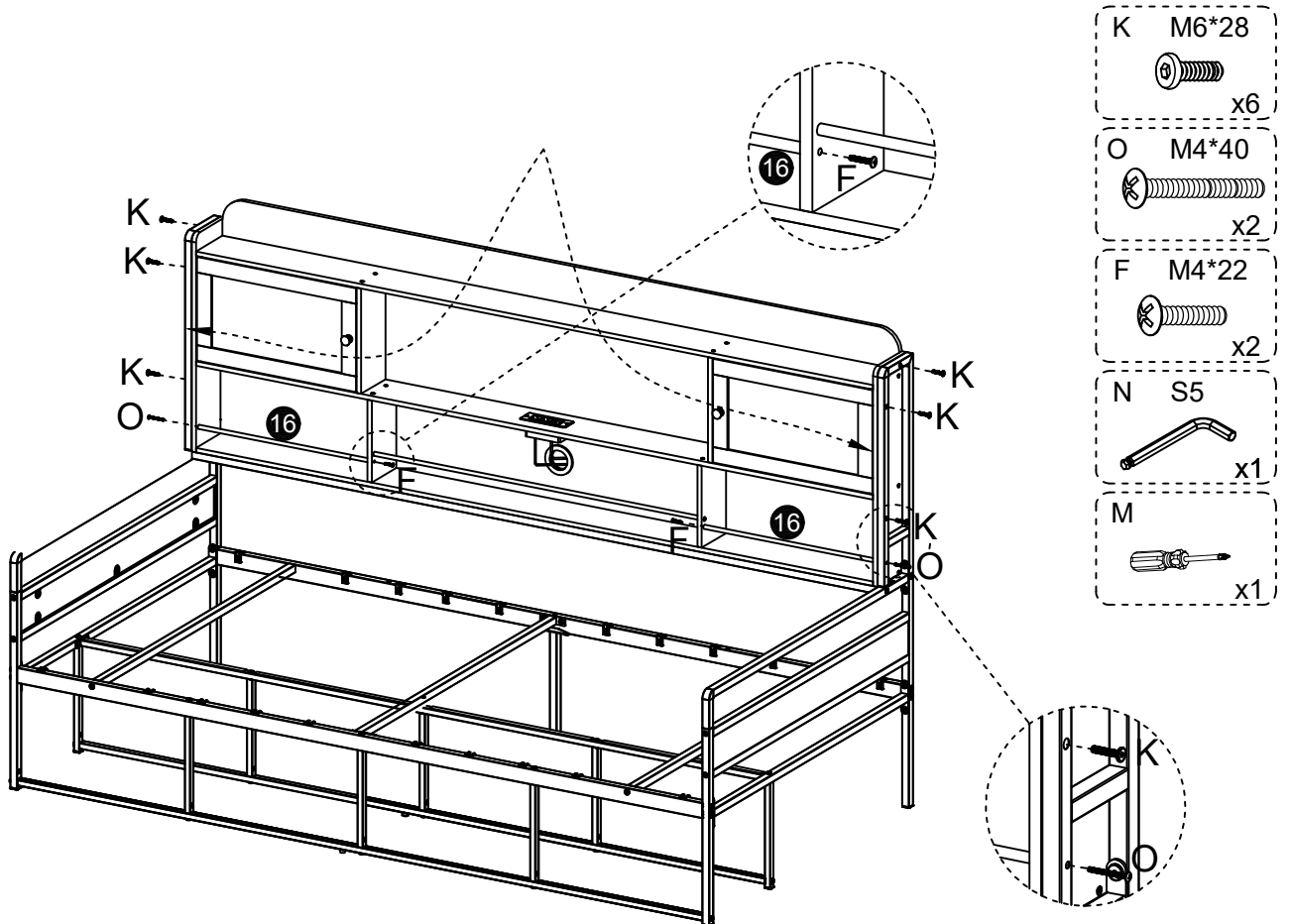

Assembly Instruction

35

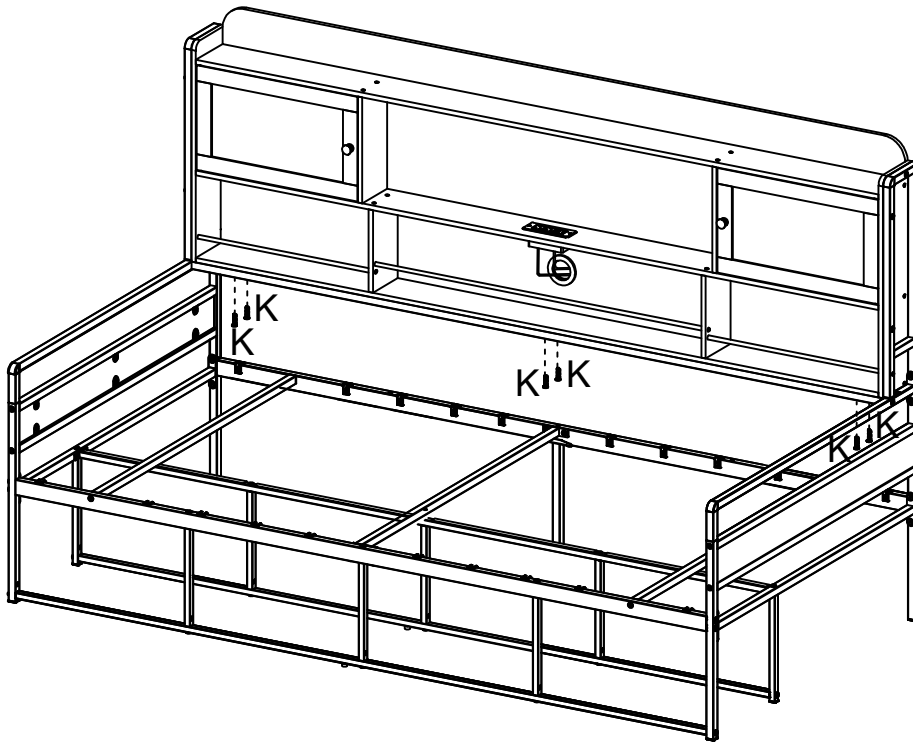
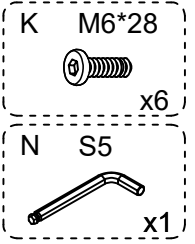

36

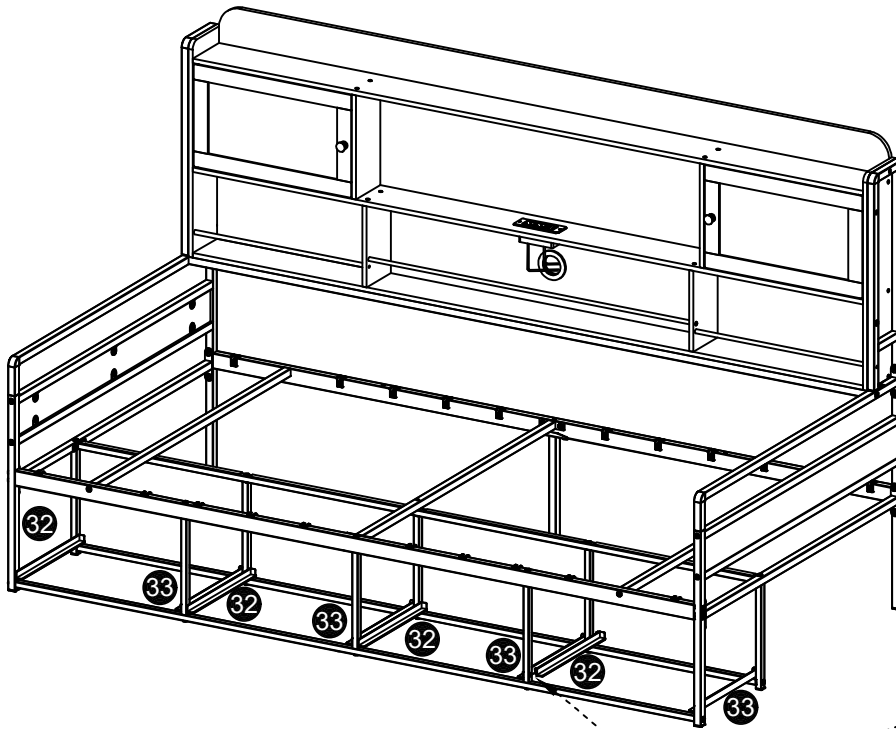

First, insert the left and right guide rails diagonally, then insert them and press down

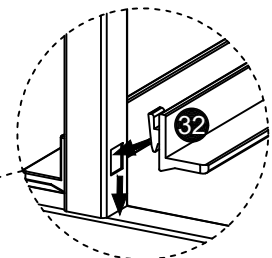

Assembly Instruction

37

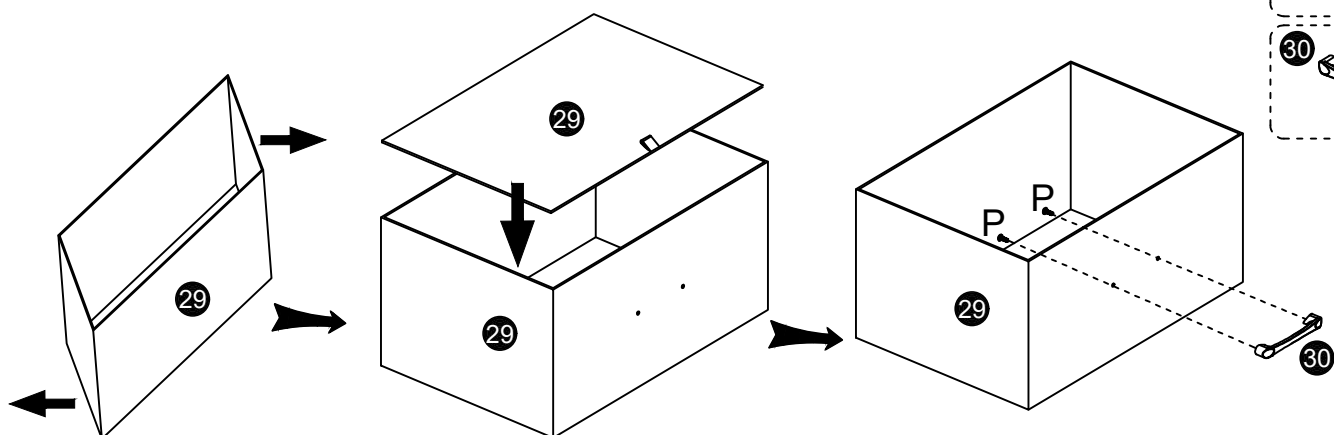

- P M4*12 x8
- M x1
- 30 x4

x4

38

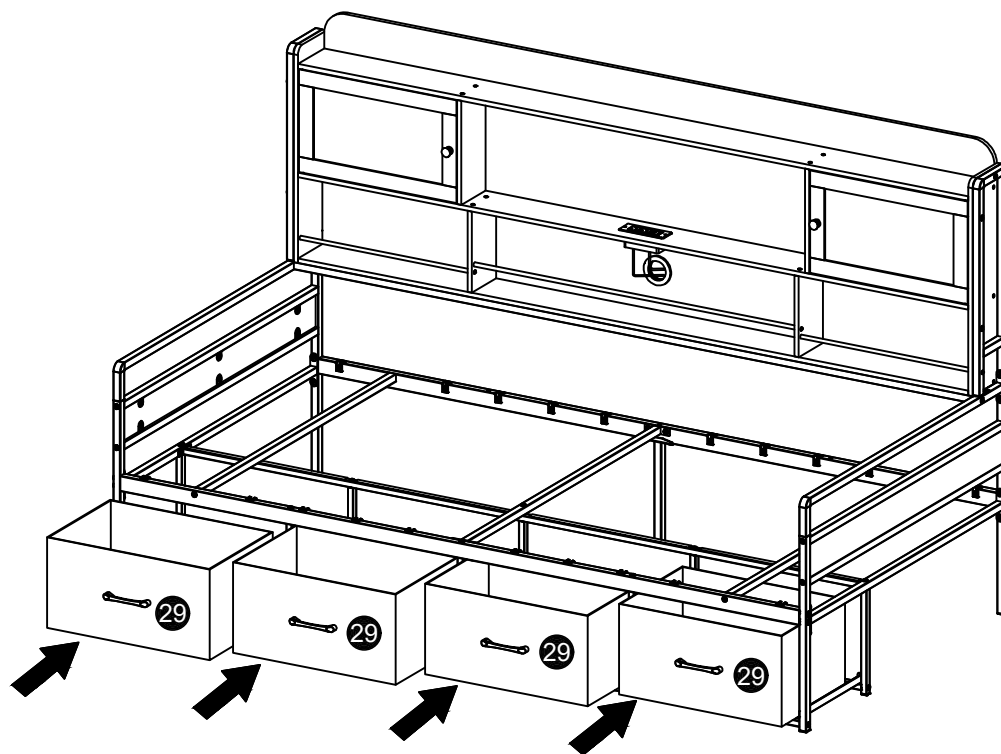

Assembly Instruction

39

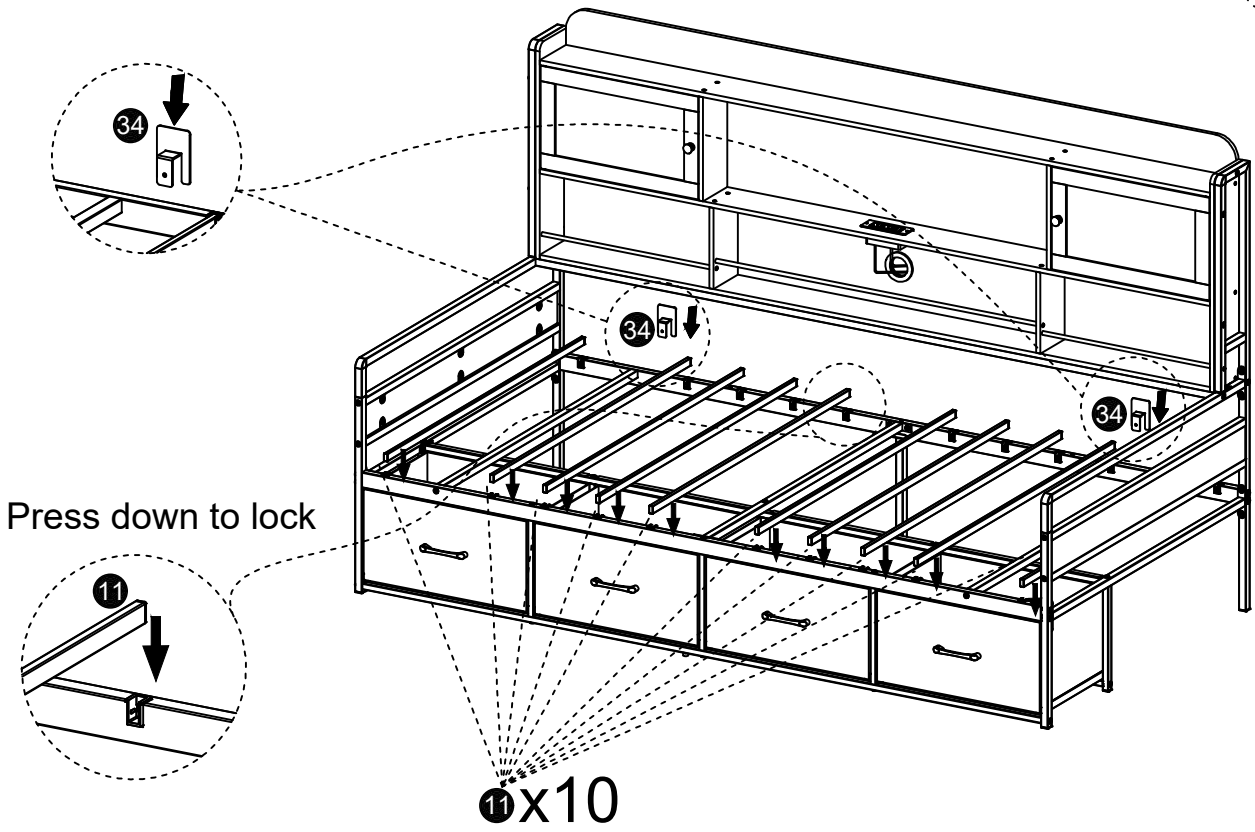
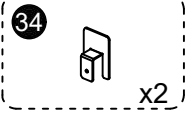

40

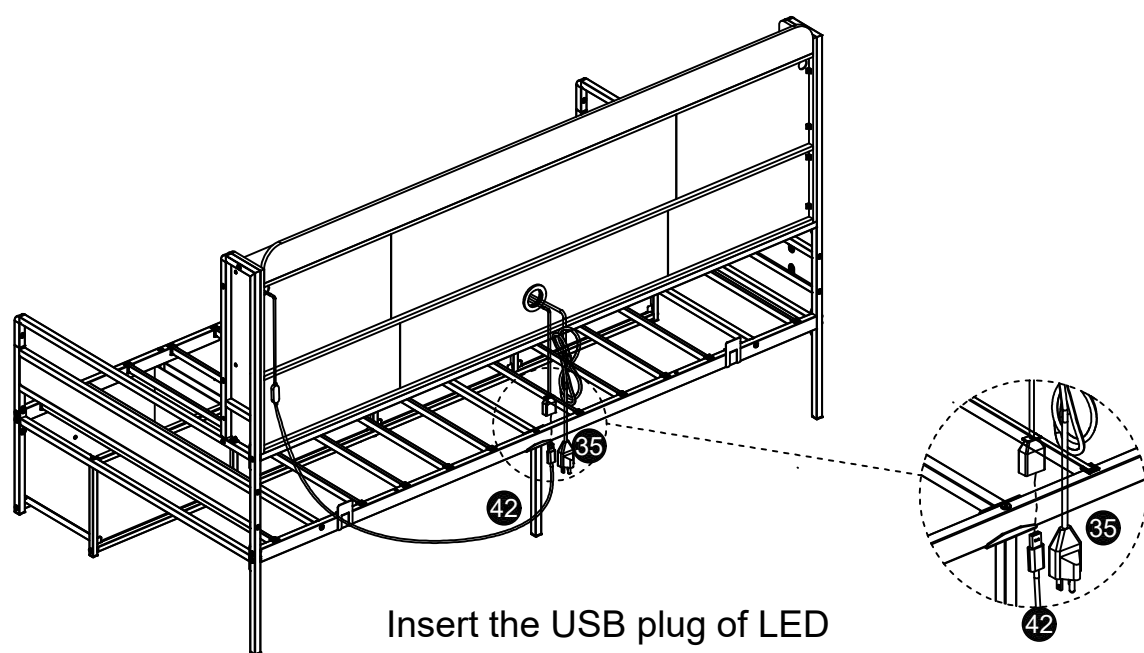

Insert the USB plug of LED light 42 into the expansion port of socket 35