

Installation Manual

Product ID. QB7VA

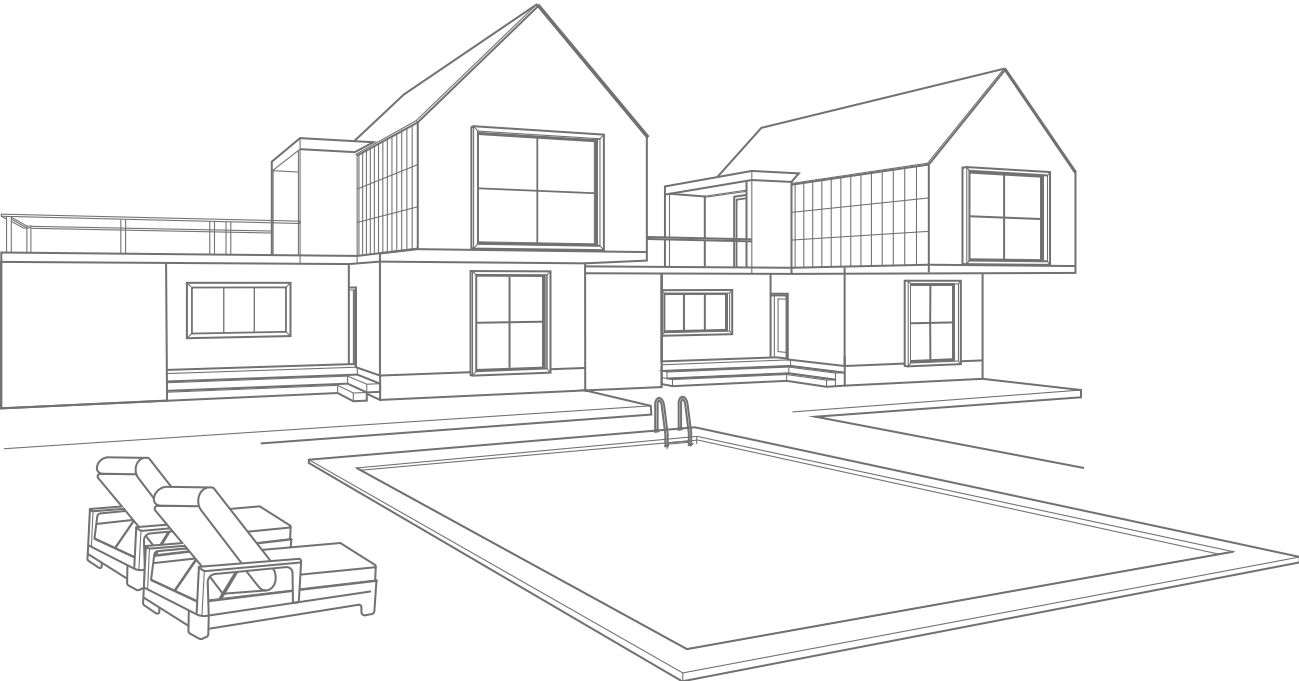

Scan for Support
support@garvee.com



Distributed by
GARVEE.com

SPU:PHO_348R

Lot NO .:YT-NO.1

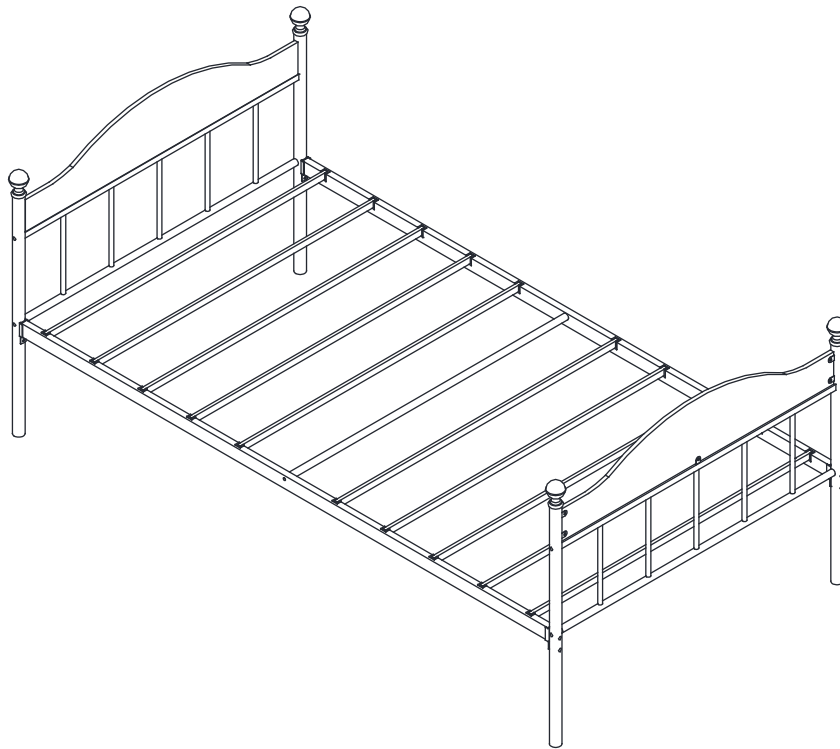

Trouble shooting:

Missing / Wrong / Broken parts and installation issues



Send email with your question, pic and order NO. to
support@garvee.com



Respond within 24 hours





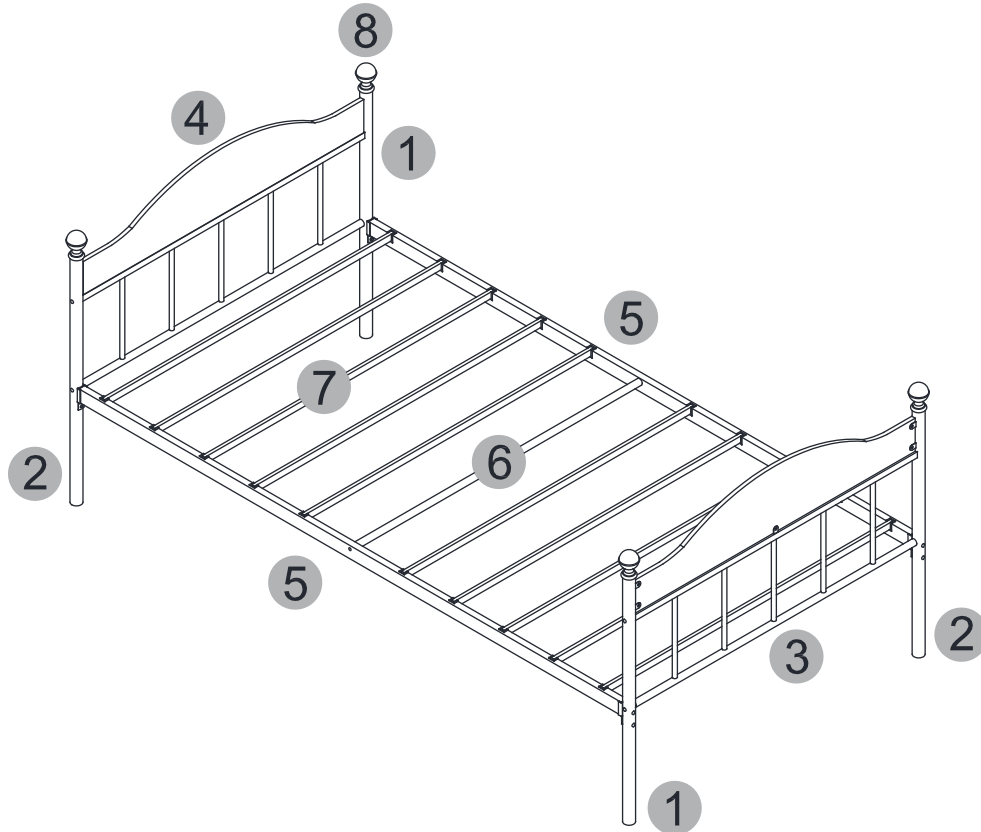





Issue resolved



Note: Don't tighten all screws during installation.

Screws & Tools ▼

A		M8x45mm	x8
B		M6x60mm	x8
C		M6x40mm	x2
D		M6x9mm	x10
E			x4
F			x16
G			x1
H			x1

Check all the components & screws before assembly

Do not install in case part is missing, contact us to get.

Send email with your question to **support@garvee.com**

We will resend with in 24 hours

Components ▼

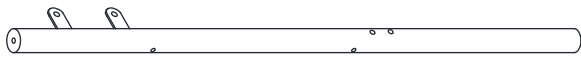

1 x2



2 x2

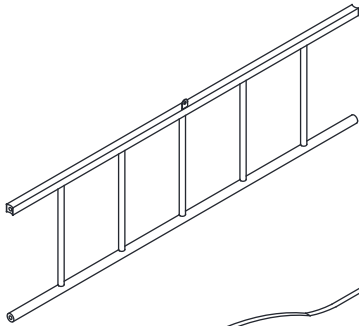

3 x2

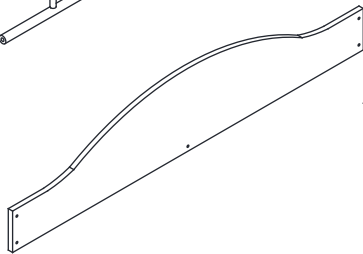

4 x2

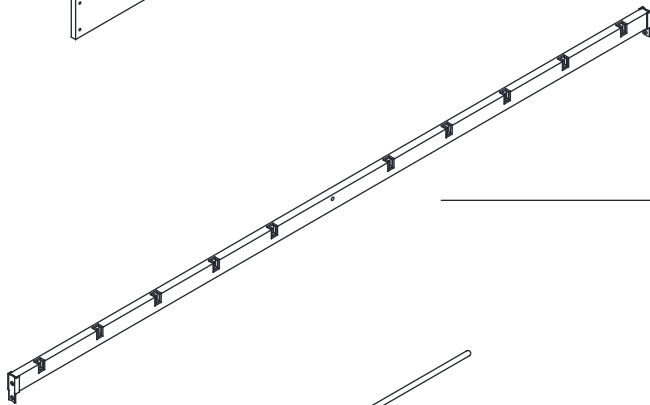

5 x2

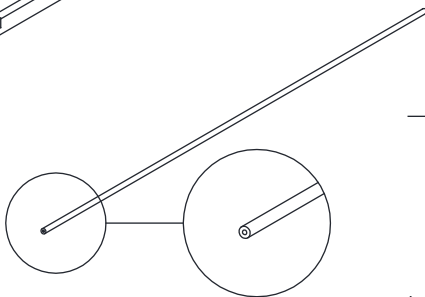

6 x1

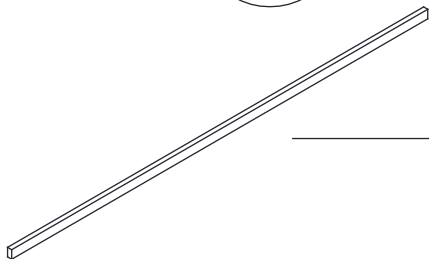

7 x10



8 x4

Step 1

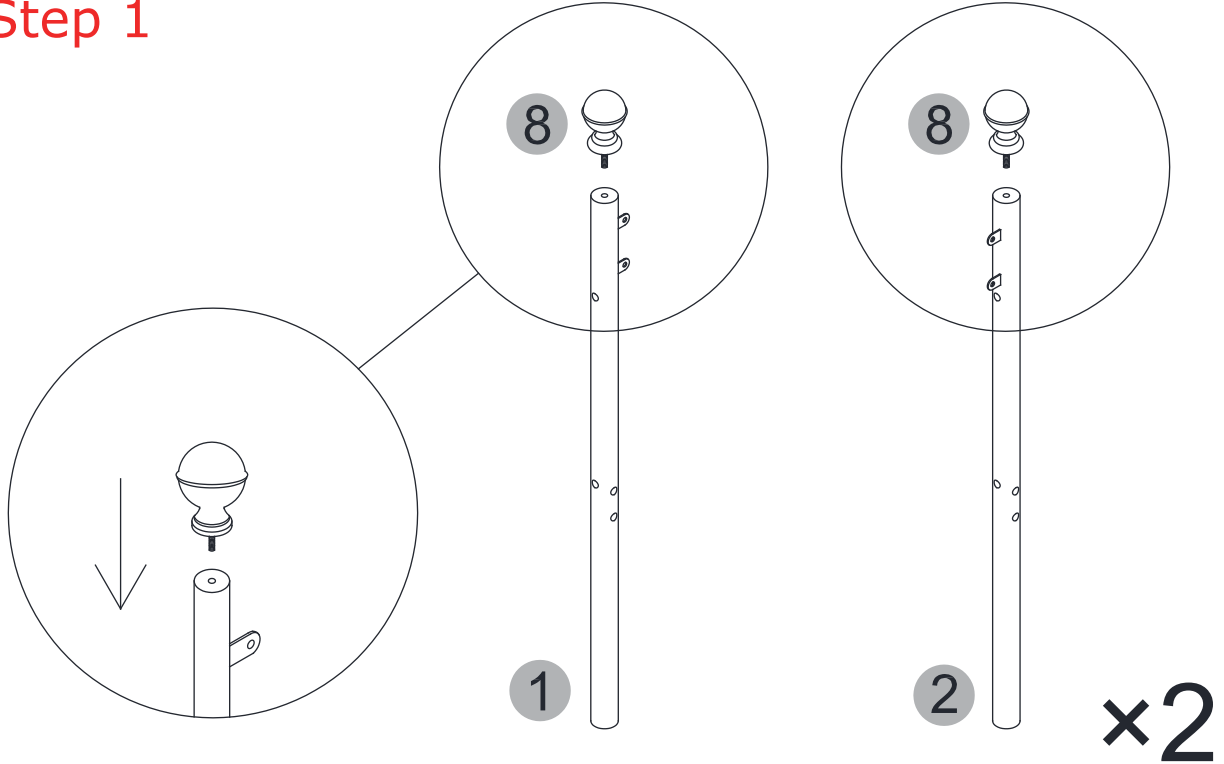

Step 2

B	M6x60mm	8PCS
F		8PCS
G		1PC

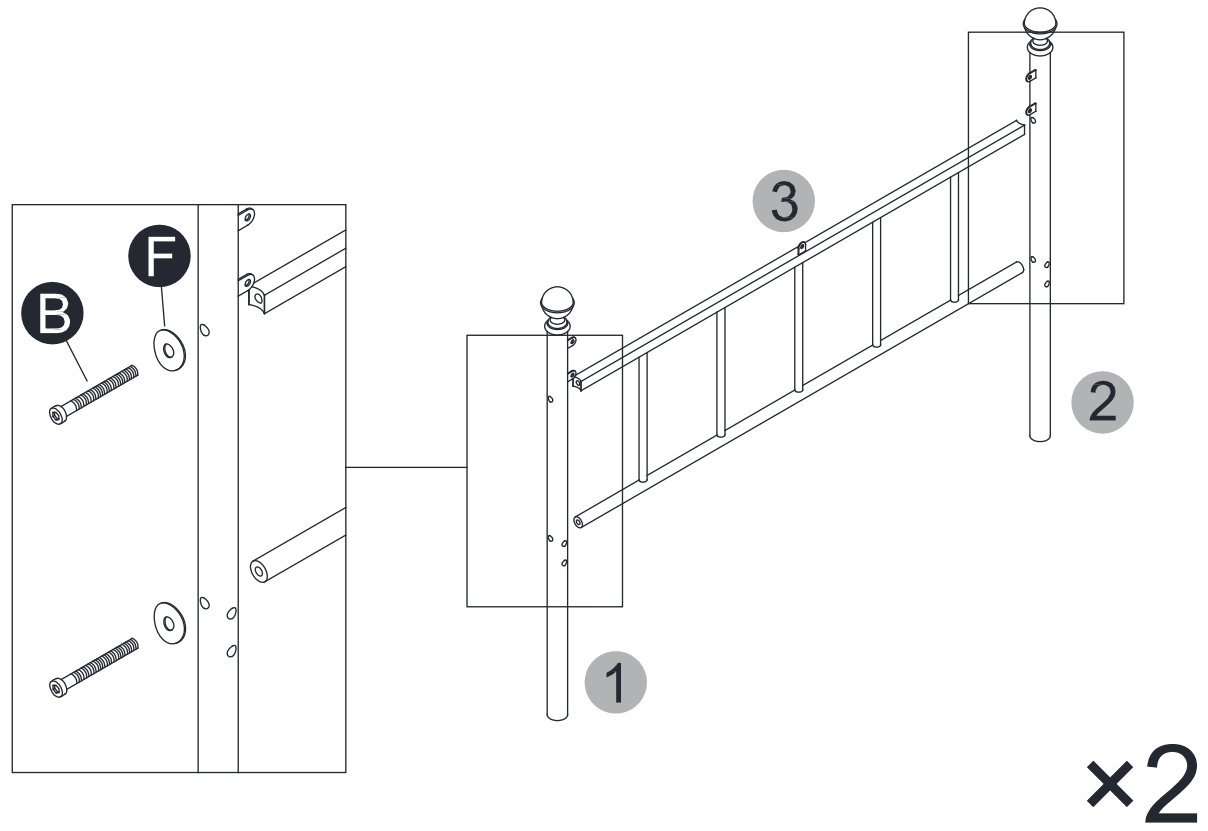



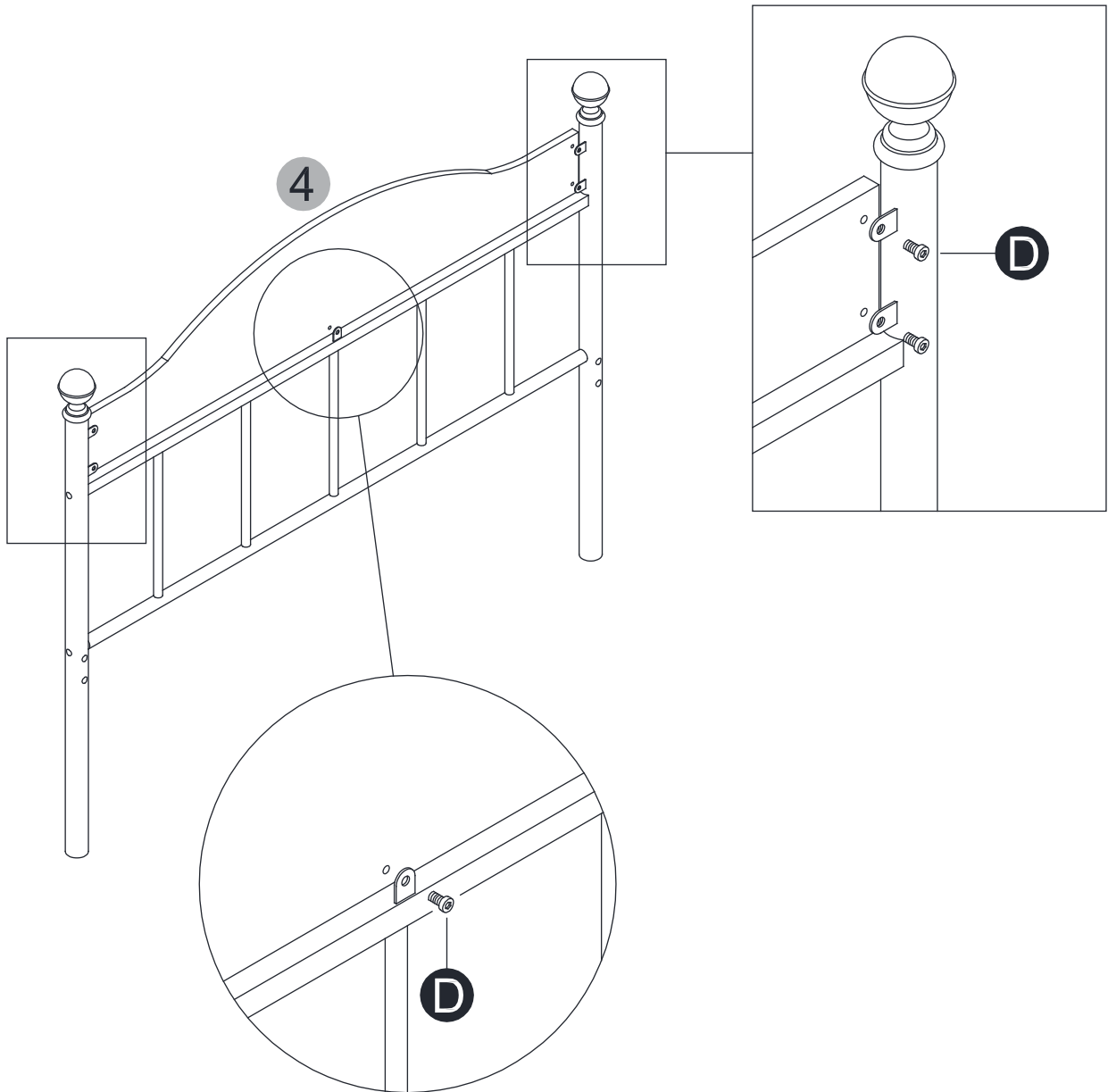

Step 3

D		M6x9mm	10PCS
G			1PC



×2

Step 4

A	 M8x45mm	8PCS
E		4PCS
F		8PCS
G		1PC
H		1PC

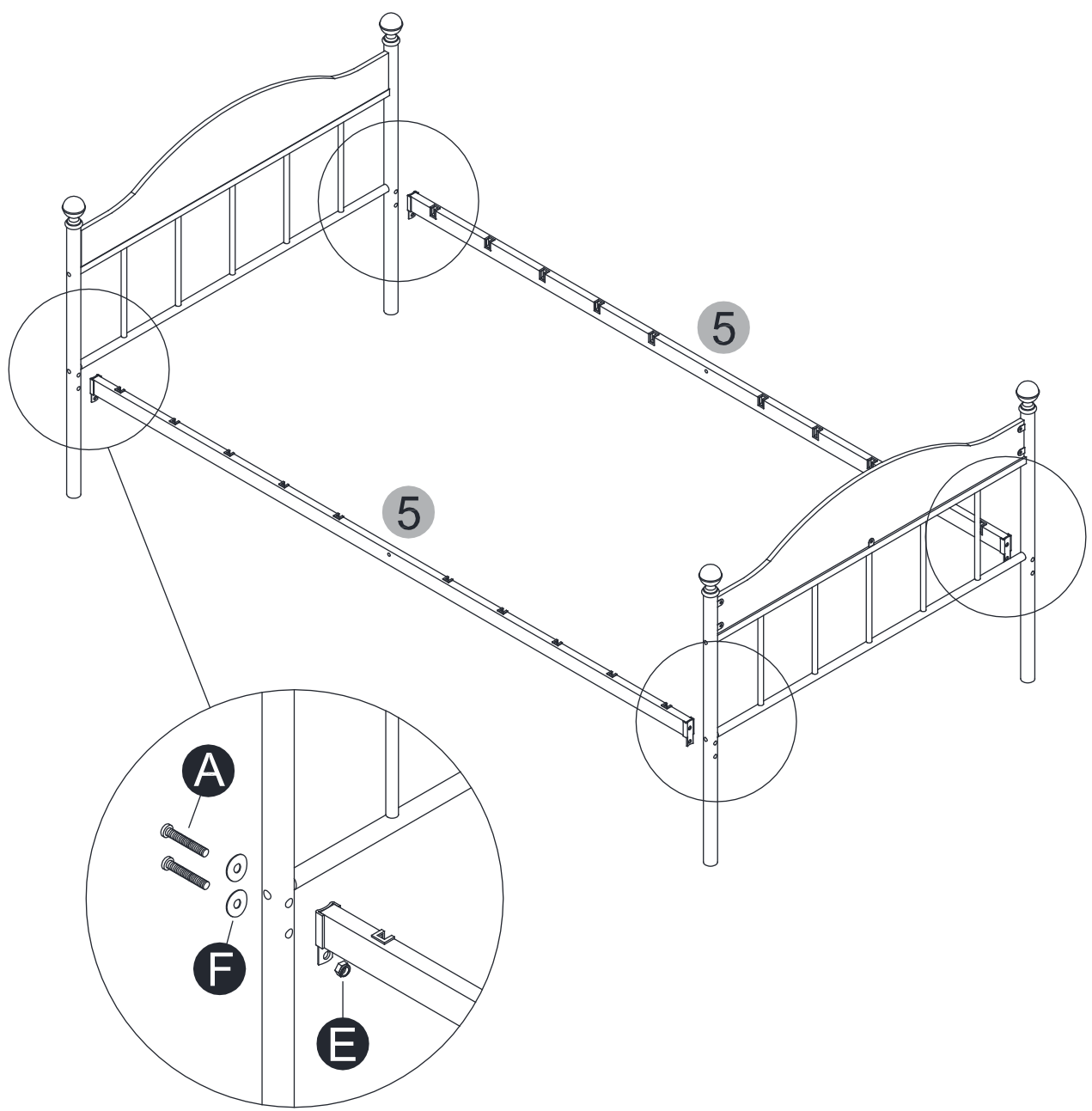

Step 5

C	 M6x40mm	2PCS
G		1PC

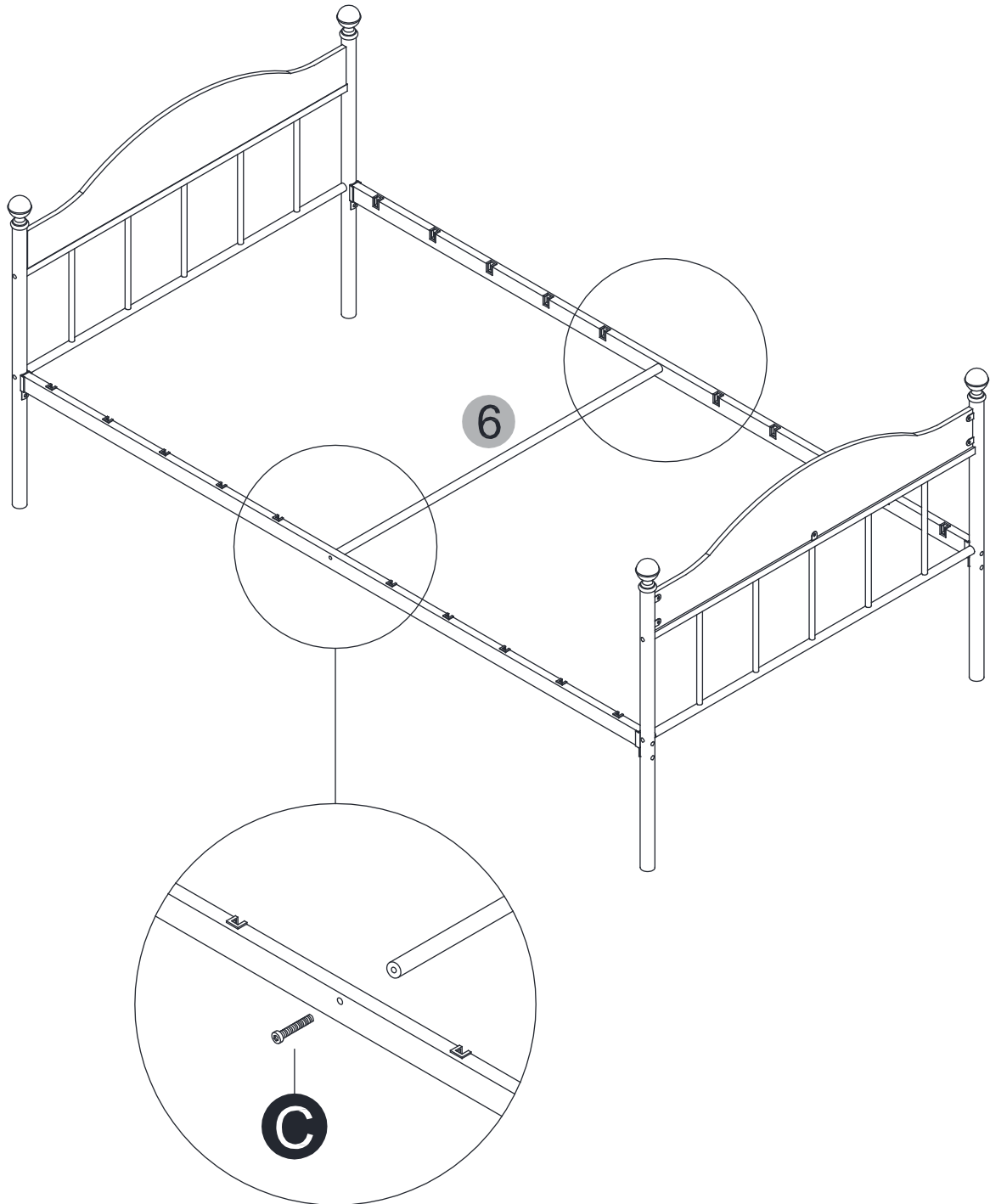

Step 6

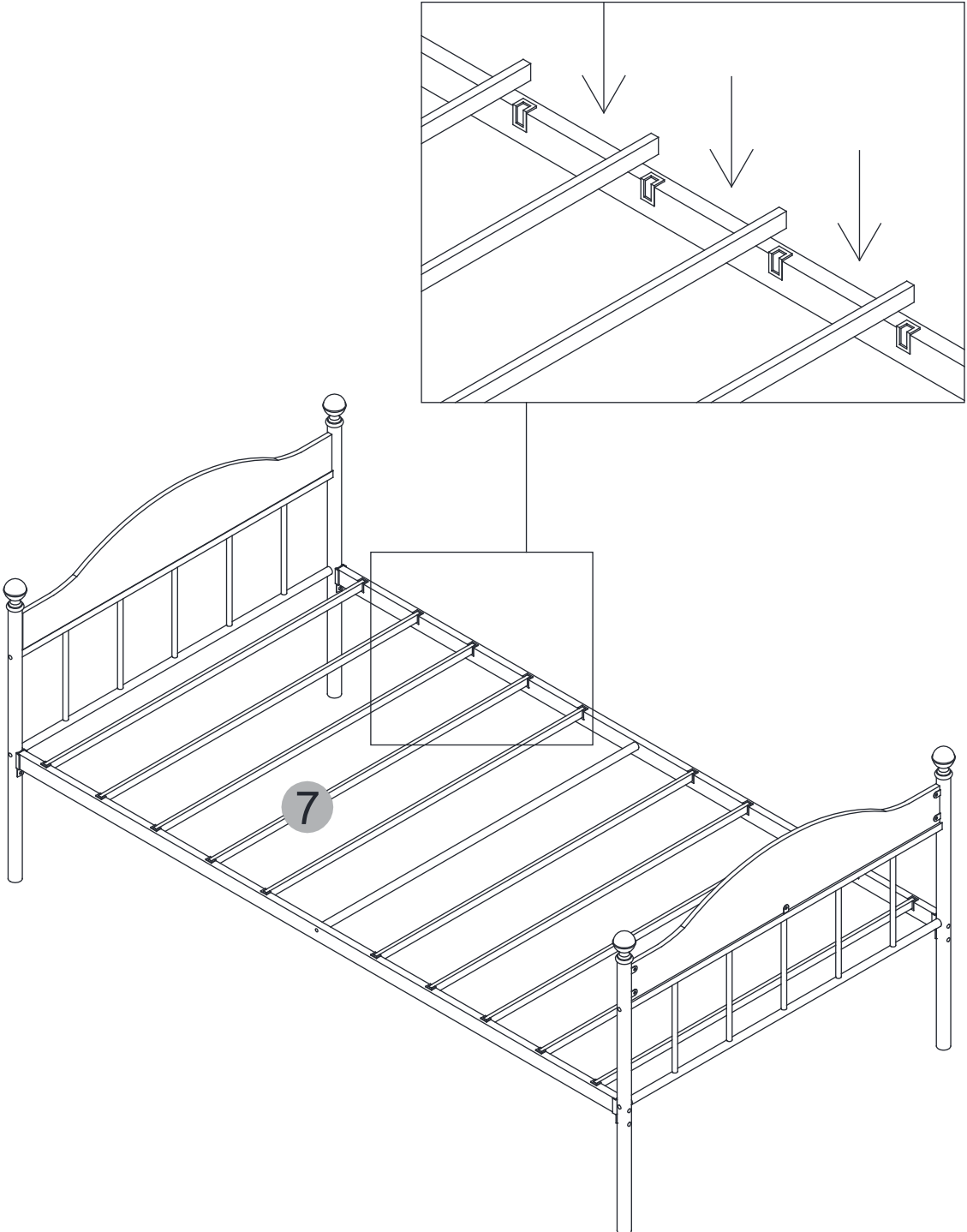

Ventilation Warning: It is recommended to ventilate for 48 hours after installation.

IMPORTANT SAFETY INFORMATION

Please carefully read the instructions and caution warnings below before assembling the product. Following this guide will ensure that you install, use and maintain the product properly.

- Please keep this installation and user manual/instructions for future reference in case you need to assemble the product.
- Do not assemble if you notice serious damage such as cracks or bends.
- During installation, please use work gloves for hand safety.
- Please assemble the unit on carpeted floor or the flat cardboard box to avoid scratching the surface or your floor while assembling on the floor.
- To assemble, please use the complimentary installation tools (Allen Wrench). Pay more attention to the direction of components at each steps.
- It is recommended that two people work together to assemble the product.
- Please do not tighten the screws up too much, just to 80% before you finish to make the installation go on successfully.

RETURN POLICY

We believe you will absolutely love your new product. But for some reason you want to return your item, please contact us within 30 days after receiving and ensure that the product which you want to return is in a good condition in the original box with all original certificates of purchase, manuals and accessories attached

HOW TO MAINTAIN YOUR PRODUCT:

- Check the screws of the product are not loose from regular use.
- Do not use sharp instruments, rubbing alcohol, corrosive chemicals, or abrasive cleaners to clean the product.
- Do not keep the product in a damp environment for a long period of time. The damp environment may cause the iron components to rust and the plates to bulge and crack.

CAUTIONS!

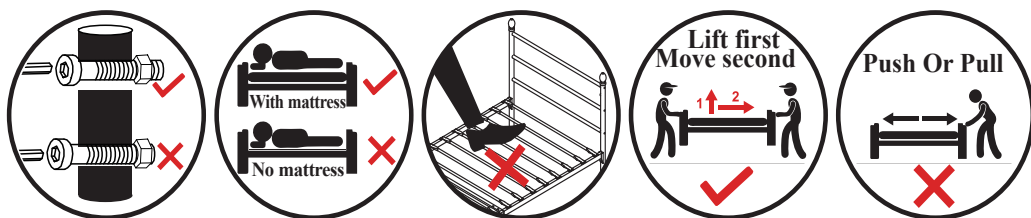

How to find us?

Customer Service

Email: support@garvee.com

CONTACT US

Dear customer, thank you for purchasing our products!

We are proud to present our customers with high quality products!



If you have any product quality or use problems, please contact our customer service by email, we will ensure your satisfaction.



support@garvee.com