















ASSEMBLY INSTRUCTIONS

Don't tighten any bolts until all bolts on a step have been started!

Thank you for purchasing this quality product. Be sure to check all packing material carefully for small parts, which may have come loose inside the carton during shipment. Identify and count all parts and compare with the **HARDWARE LIST** below.

NO.	PARTS LIST		Q'TY
A		Stool back	1
B		Bonded Fabric seat	1
C		Top ring	1
D		Metal swivel	1
		Middle ring	Pre-assy
E		Bottom ring	1
F		Leg	4

NO.	HARDWARE LIST		Q'TY
1		1/4"x2"	14
2		1/4"x1-1/2"	4
3		1/4"x1"	4
4		1/4"	22
5		1/4"x19mm	22
6		7*15mmL	4
7		Allen Wrench	1

STEP 1:

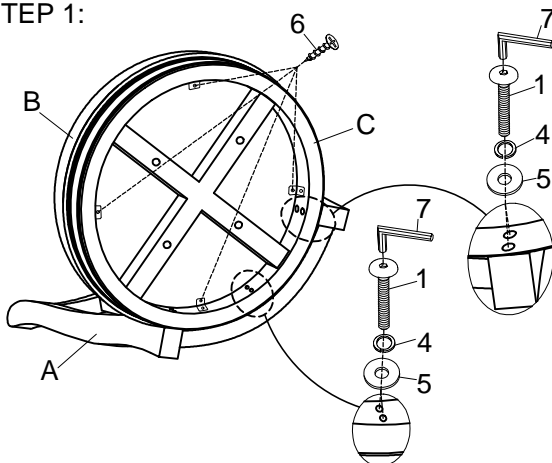

1. Attach the Stool back(A) to the Top ring(C) using Bolts(7+1+4+5) to tighten, as shown.
2. Attach the Bonded leather seat(B) to the(A+C), using Screws(6) to tighten, as shown.

STEP 2:

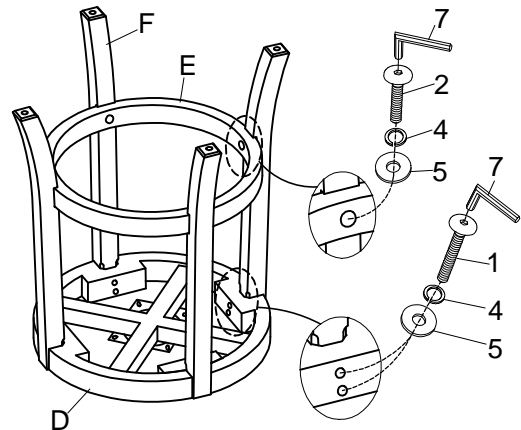

1. Attach the four Legs(F) to the Middle Ring(D), using Bolts(7+1+ 4+5) to tighten, as shown
2. Attach the Bottom Ring(E) to the Legs, using Bolts (7+2+ 4+5) to tighten, as shown.

STEP 3:

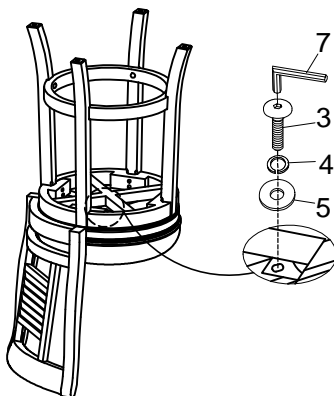

1. Upside down the Wooden Seat Back(STEP1) and put it on a smooth and stable working stand.
2. Attach the Stool Base(STEP2) to the Seat w/ pre-assembly Seat Back(STEP 1), using a Phillips head screwdriver (not included) and Bolts(7+3+4+5) to tighten, as shown.

STEP 4:

- 1.Right side up the stool.
- 2.It's complete for using.

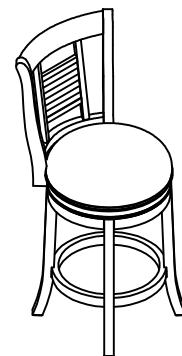

- Caution: 1. All bolts must be tightened mandatorily in each step.
2. It is also recommended to periodically check bolts and re-tighten as needed. "