

Bed Frame

Instruction Manual

Estructura de Cama

Manual de Instrucciones

Cadre de lit

Manuel d'Instruction

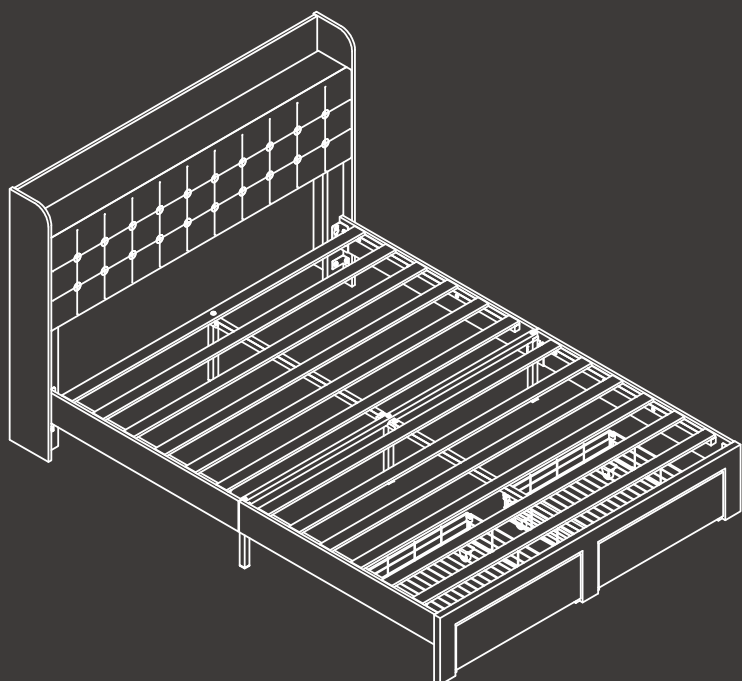

1 Precautions / Precauciones / Précautions

EN

Please read the instruction manual carefully before installation and keep it for future reference.

1. Check that all parts are present and intact. Keep them away from children.
2. Install the product on a clean, flat, and soft surface (such as carpet or cardboard) to avoid scratching or damaging it.
3. The main components of the product are relatively heavy. Please pay attention to safety during installation.
4. The product is not stable during installation. Do not move it randomly before it is completely installed.
5. If you have any questions during installation, please contact our after-sales service.

ES

Lea este manual de instrucciones minuciosamente antes de la instalación y guárdelo para referencia futura.

1. Verifique que todas las piezas estén presentes e intactas. Manténgalas fuera del alcance de los niños.
2. Instale el producto sobre una superficie limpia, plana y suave (como una alfombra o cartón) para evitar rayarlo o dañarlo.
3. Los componentes principales del producto son relativamente pesados. Preste atención a la seguridad durante la instalación.
4. El producto no es estable durante el montaje. No lo mueva hasta completar la instalación.
5. Si tiene alguna duda durante la instalación, póngase en contacto con nuestro servicio posventa.

FR

Veillez lire attentivement le manuel d'instructions avant l'installation et le conserver pour référence ultérieure.

1. Vérifiez que toutes les pièces sont présentes et intactes. Gardez-les hors de portée des enfants.
2. Installez le produit sur une surface propre, plane et souple (comme un tapis ou un carton) afin d'éviter de le rayer ou de l'endommager.
3. Les principaux composants du produit sont relativement lourds. Veillez prêter attention à la sécurité pendant l'installation.
4. Le produit n'est pas stable pendant l'installation. Ne le déplacez pas au hasard avant qu'il soit complètement installé.
5. Si vous avez des questions pendant l'installation, veuillez contacter notre service après-vente.

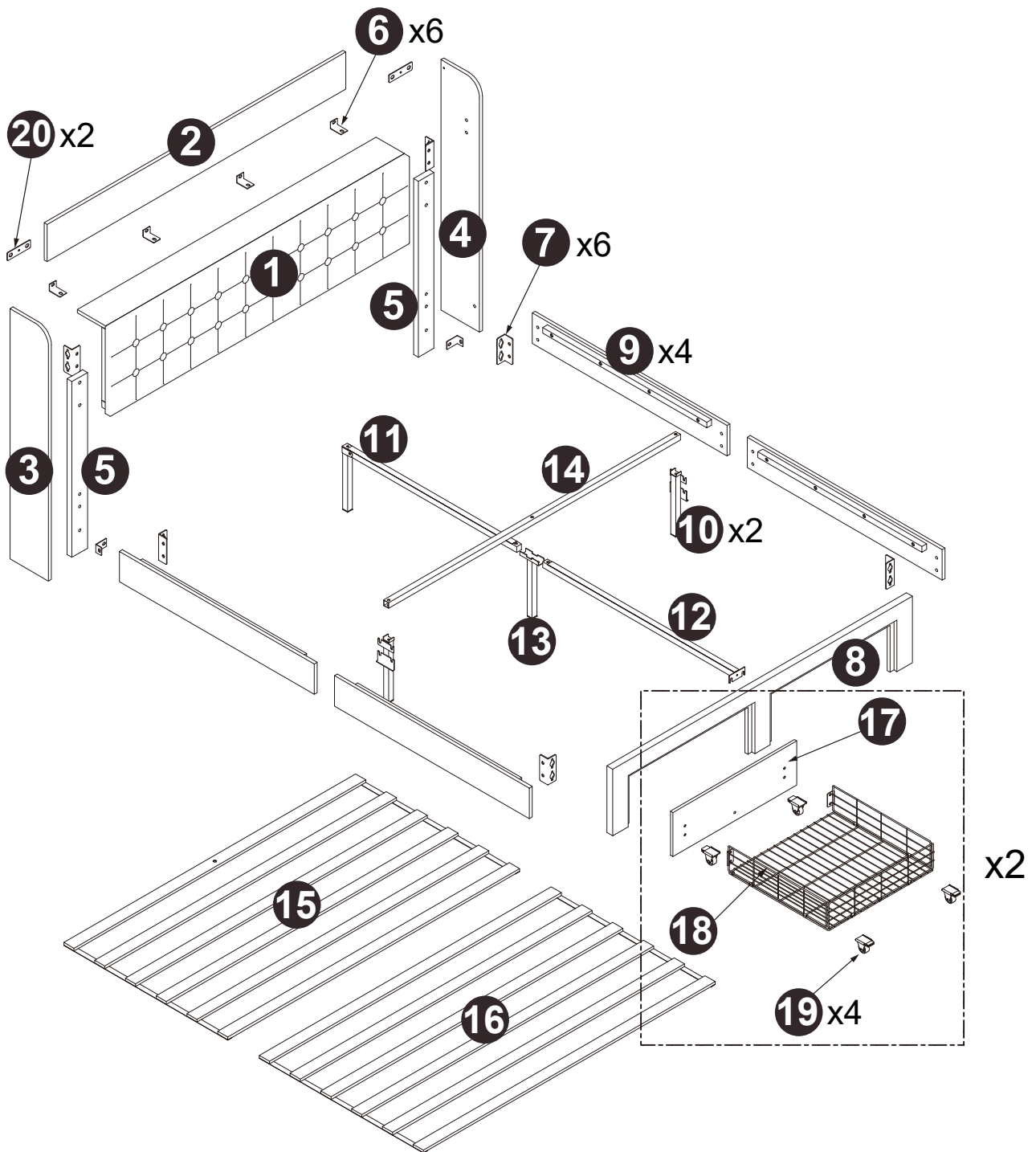

EN **Note:** The installation is easier with two people.

ES **Nota:** La instalación es más sencilla con dos personas.

FR **Remarque :** L'installation est plus facile à deux.

1 X1

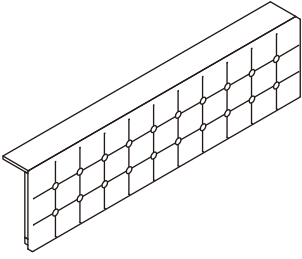

2 X1

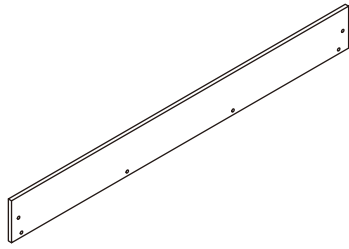

3 X1



4 X1



5 X2



6 X6

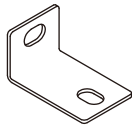

7 X6

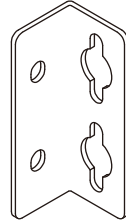

8 X1

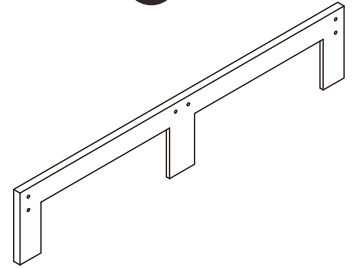

9 X4

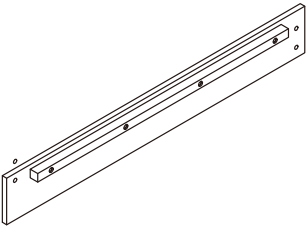

10 X2

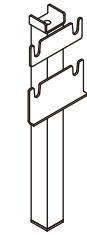

11 X1

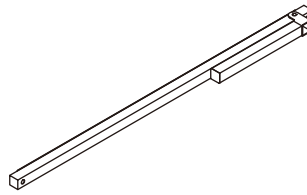

12 X1

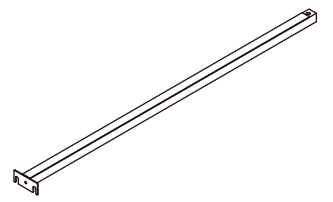

13 X1

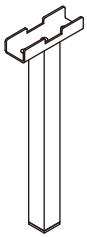

14 X1

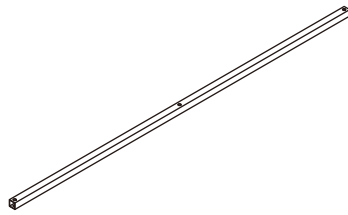

15 X1

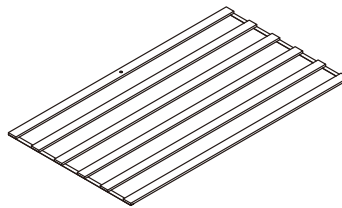

16 X1

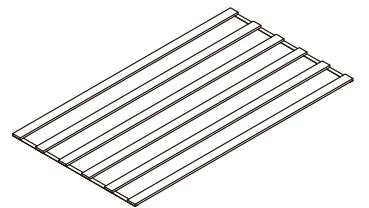

17 X2

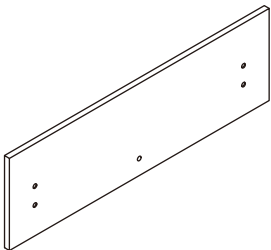

18 X2

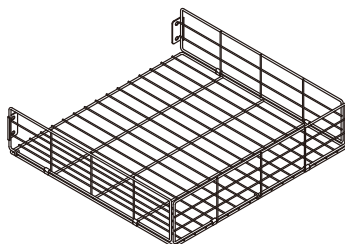

19 X8

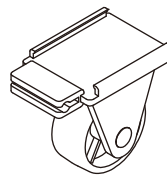

20 X2

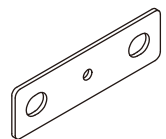

A X1



1/4" x 45mm

B X44

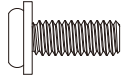

5/16" x 19mm

C X6

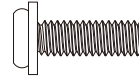

5/16" x 25mm

D X4

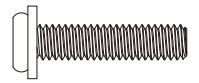

5/16" x 35mm

E X5

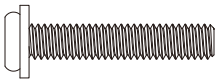

5/16" x 45mm

F X10



1/4" x 13mm

G X2

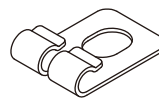

H X4

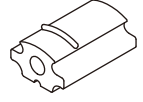

I X4

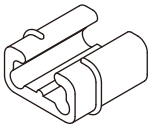

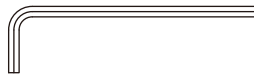

J X1





M4x100mm

5

EN:  Partially tighten the screws.

ES:  Apriete parcialmente los.

FR:  Serrez partiellement.

 Partially tighten the screws.

 Apriete parcialmente los.

 Serrez partiellement.

 Fully tighten the screws.

 Apriete completamente los tornillos.

 Serrez complètement les vis.

Step 1

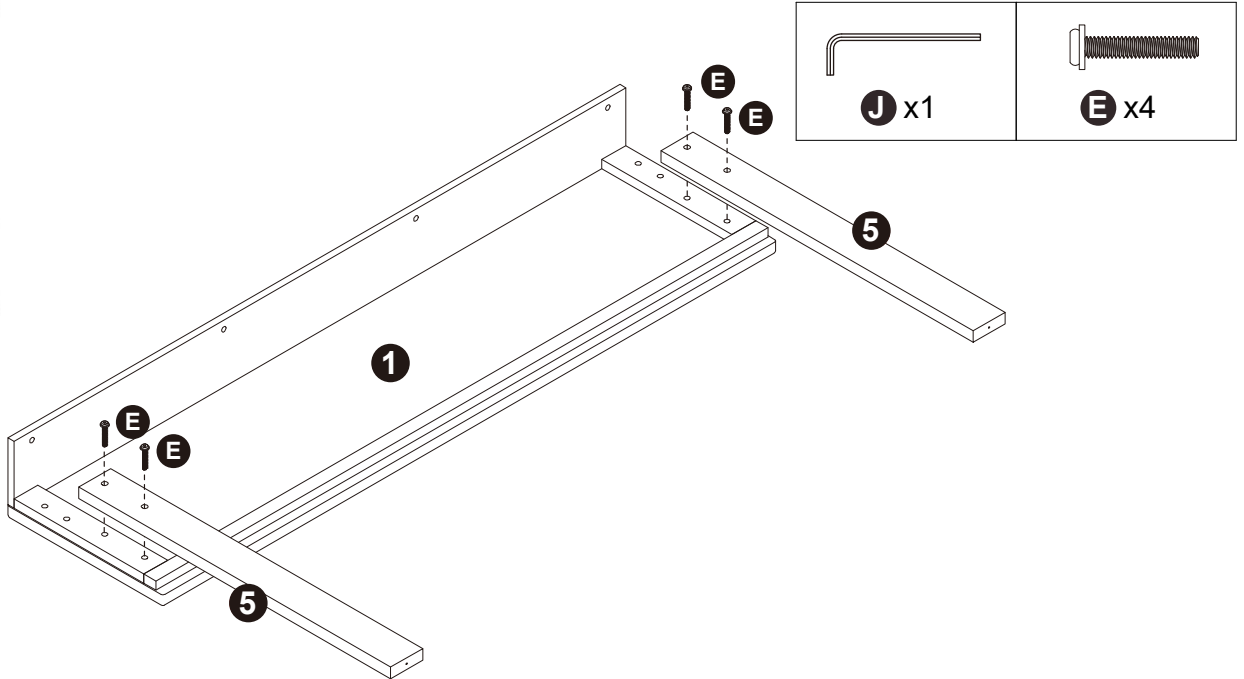
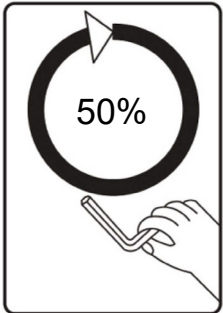

Step 2

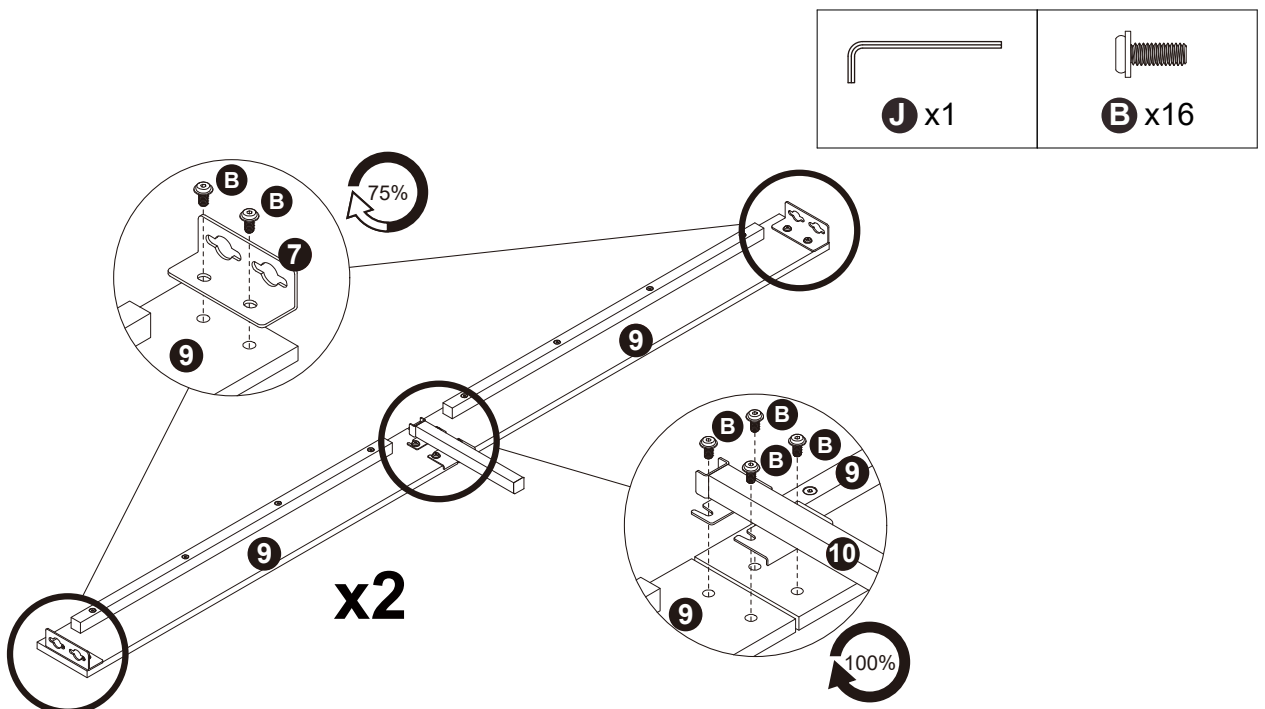

Step 3

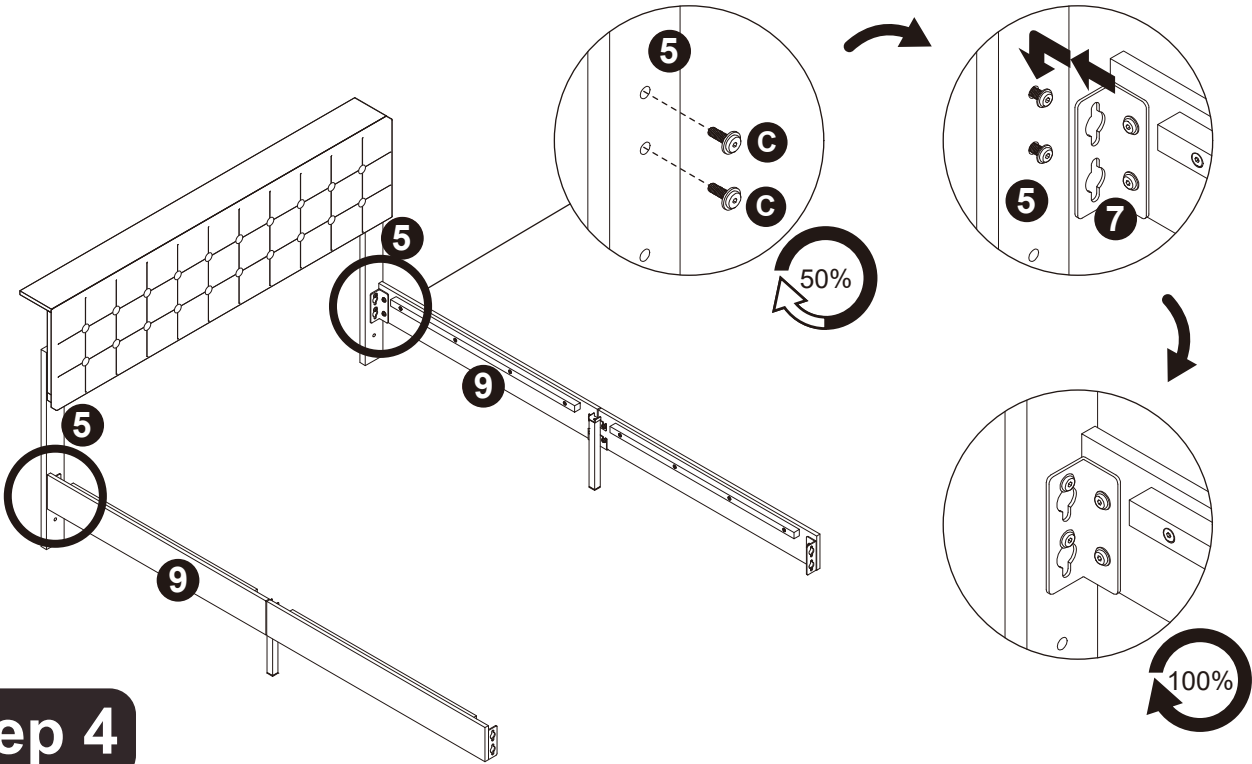
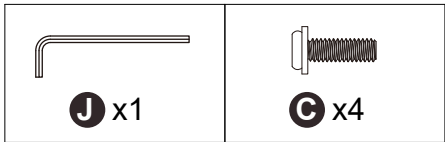

Step 4

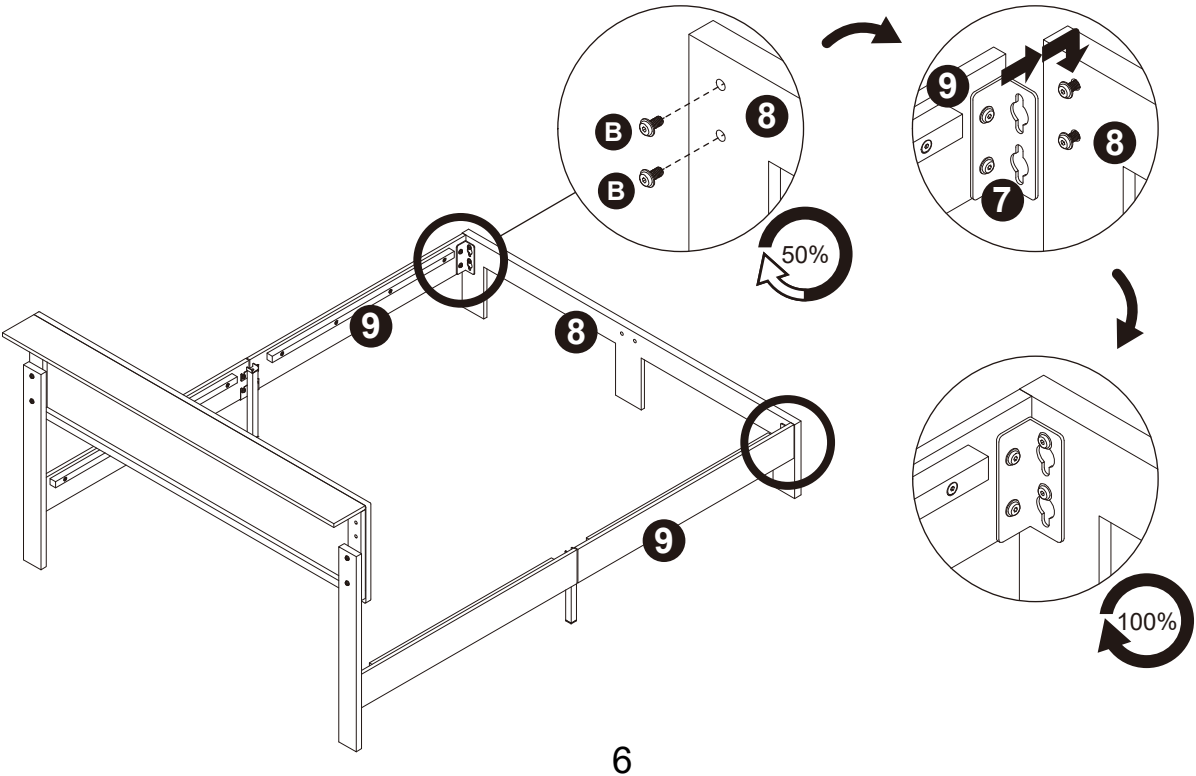
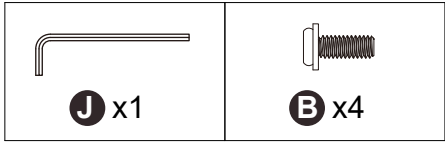

Step 5

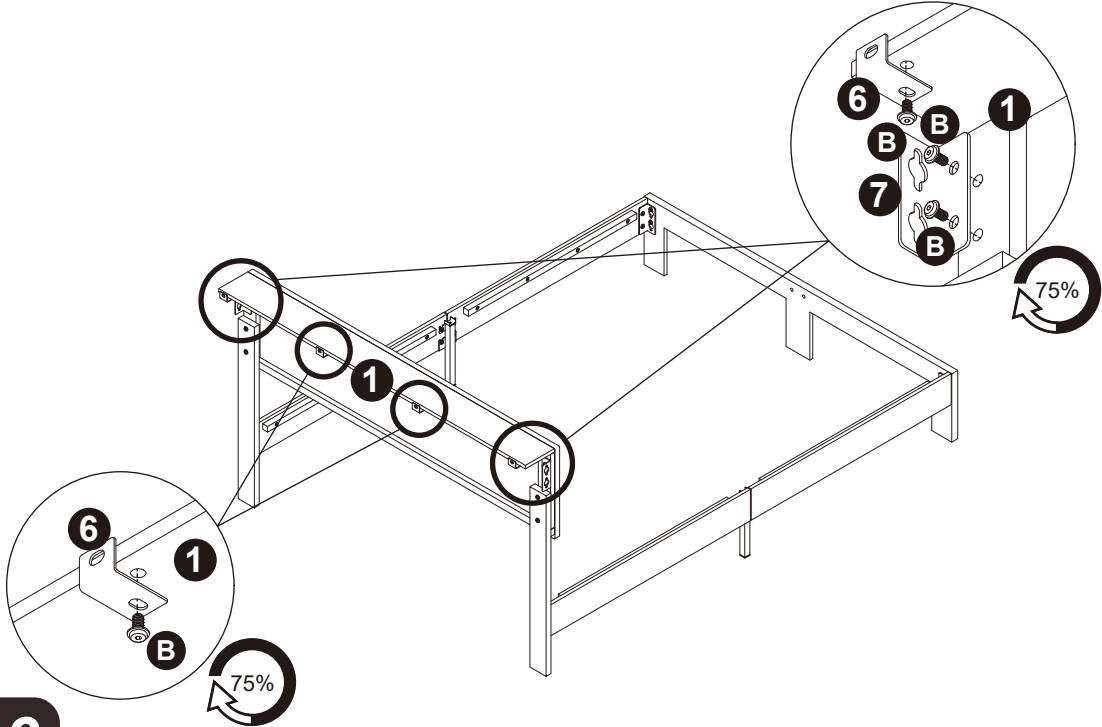
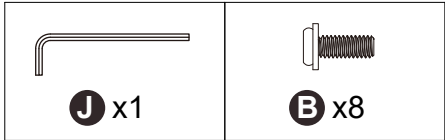

Step 6

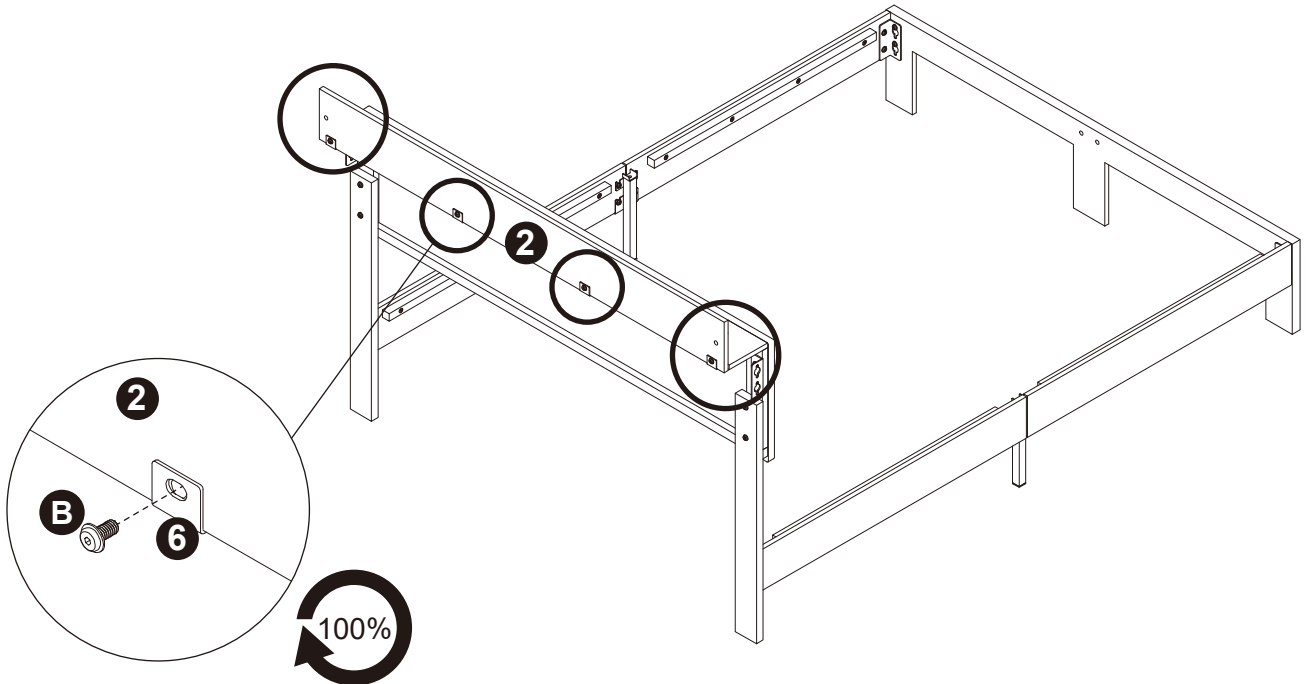
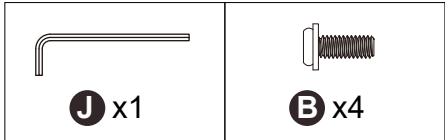

Step 7

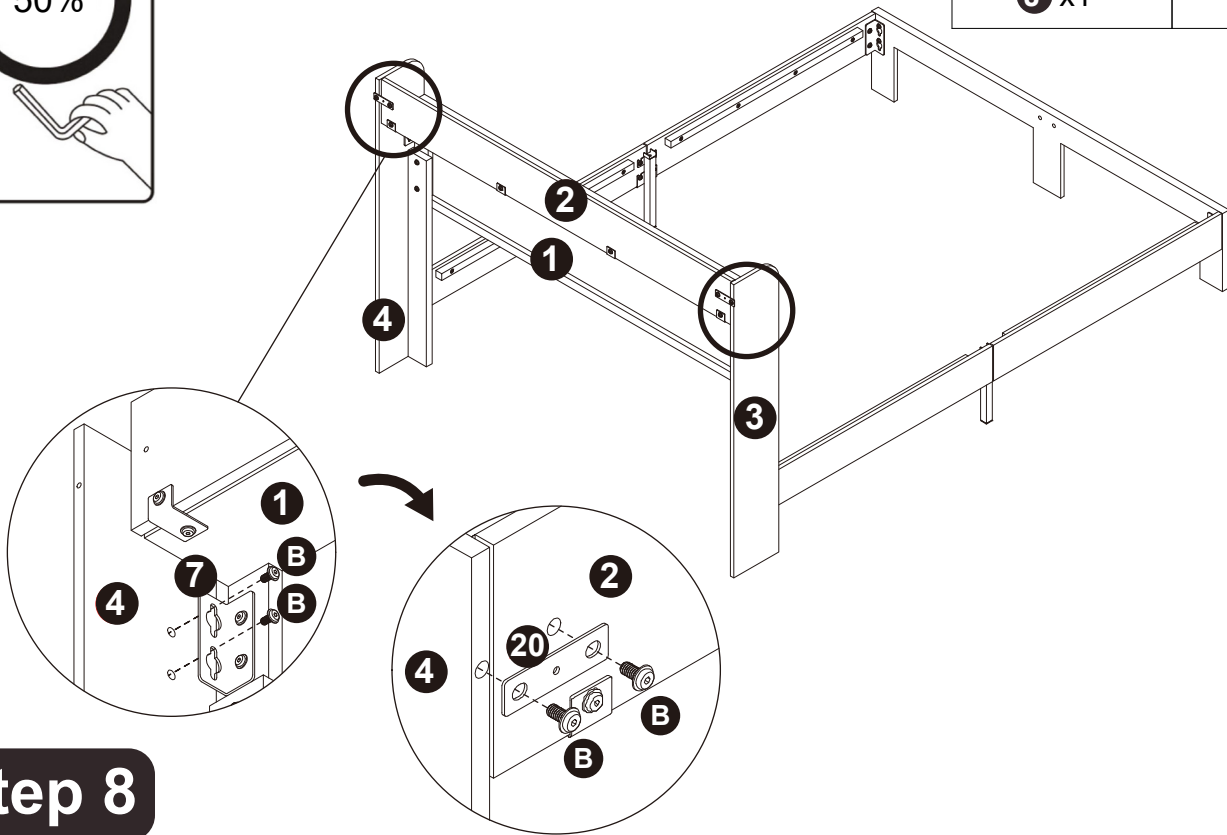
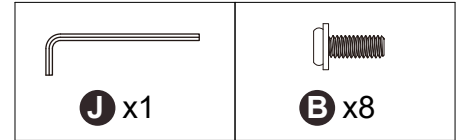
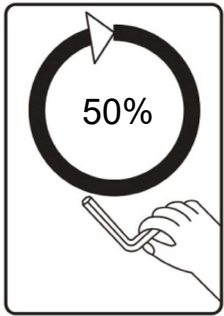

Step 8

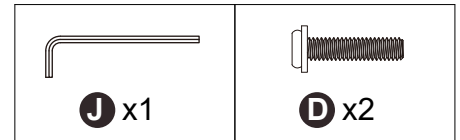
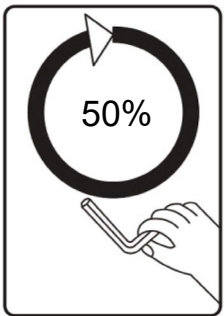

EN: Pad facing up
 ES: Con la almohadilla hacia arriba
 FR: Plaquette face vers le haut

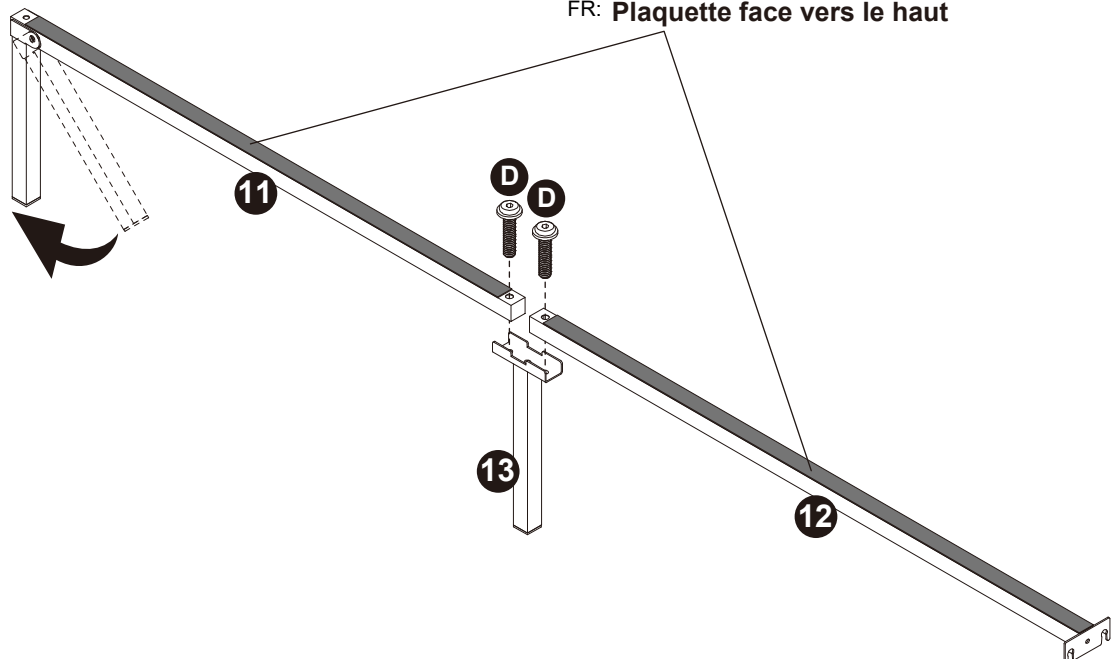

Step 9

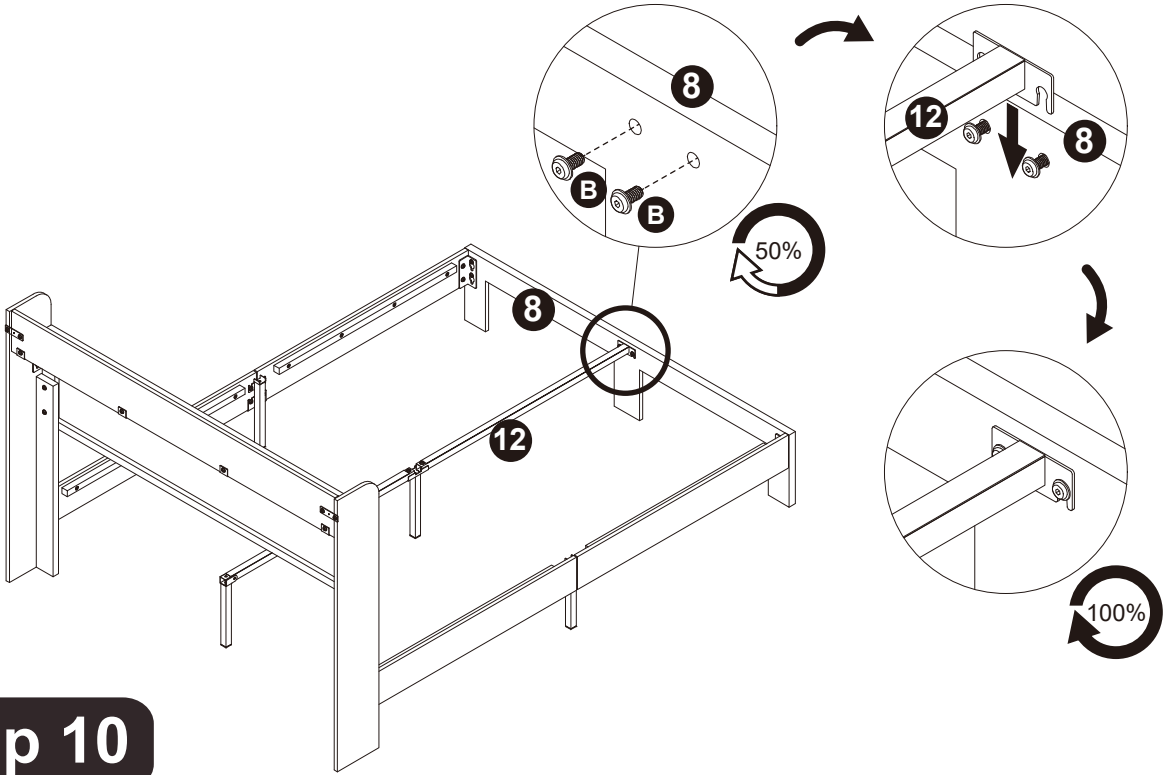
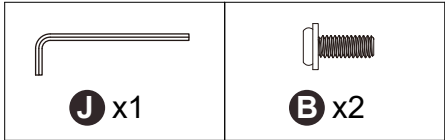

Step 10

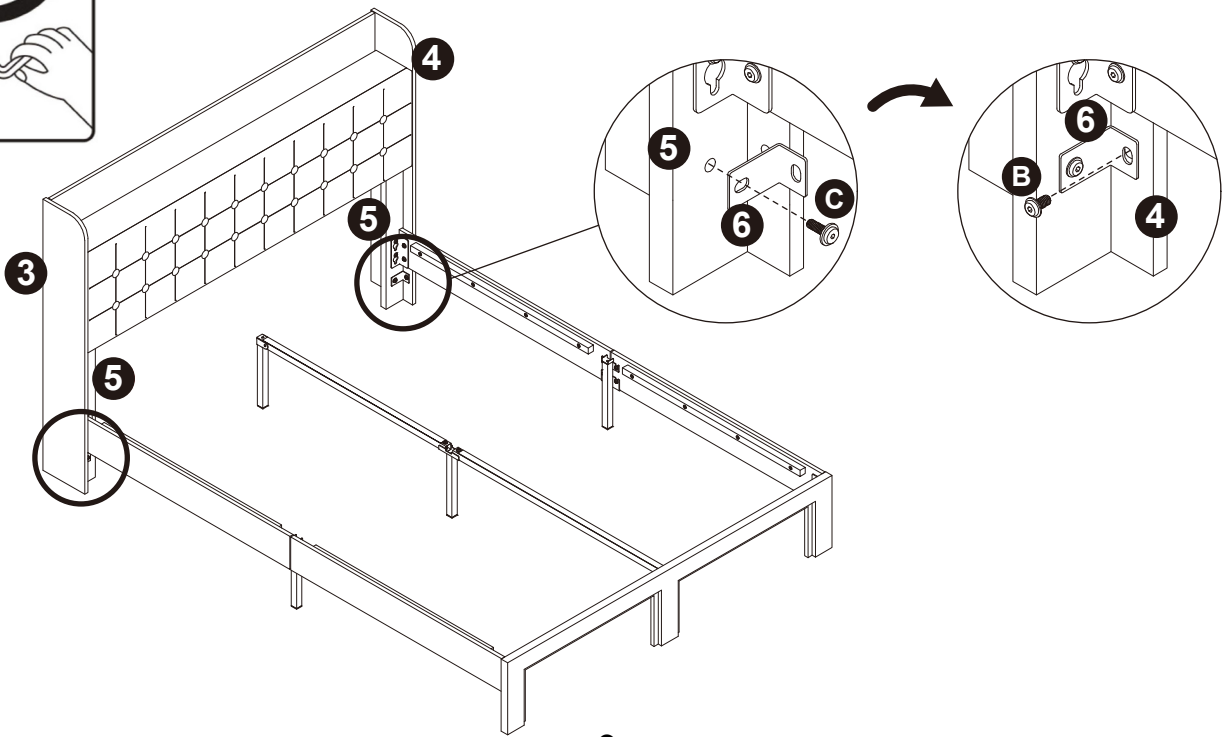
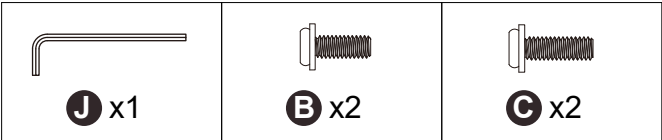
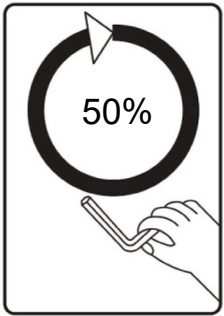

Step 11

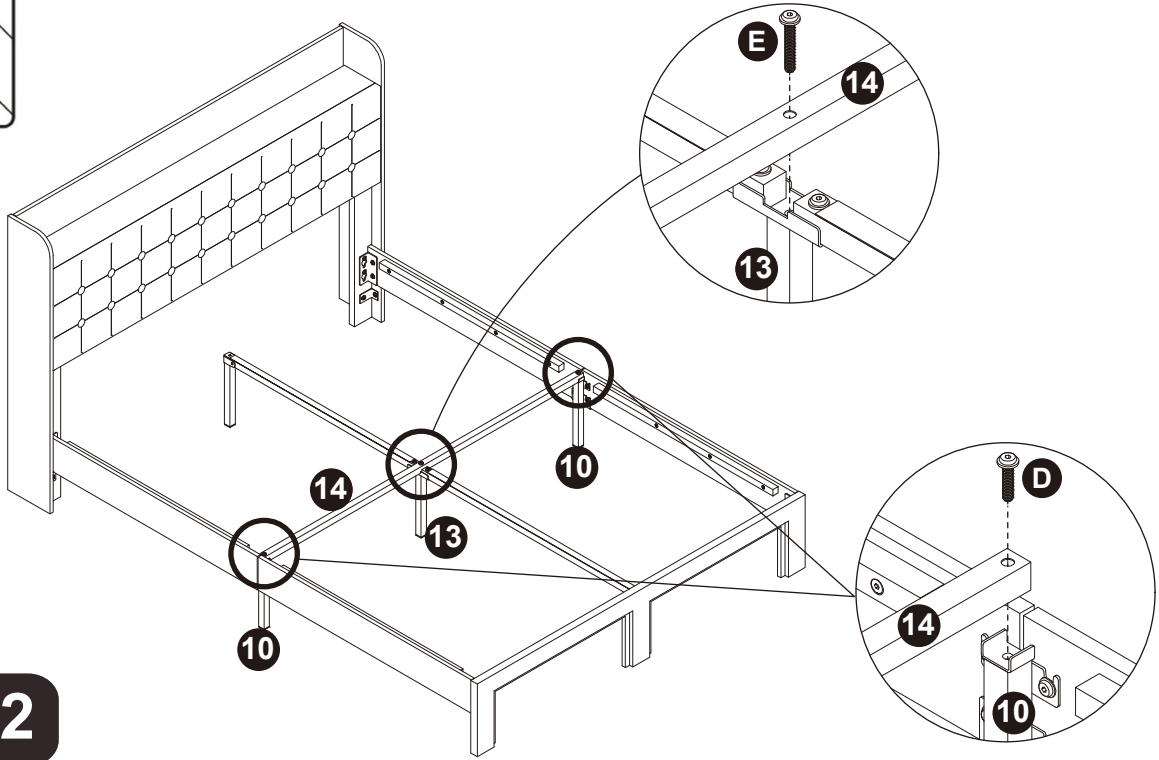
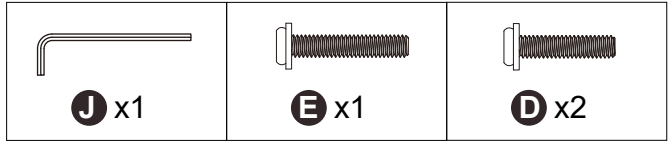
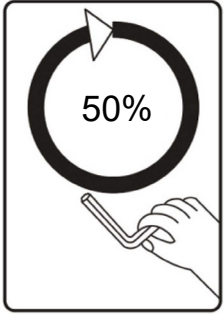

Step 12

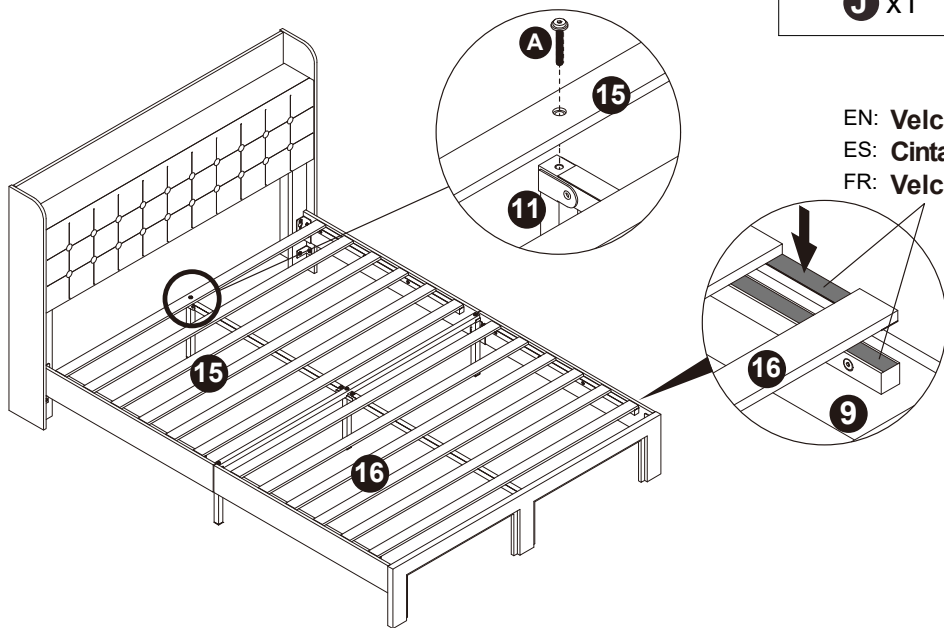
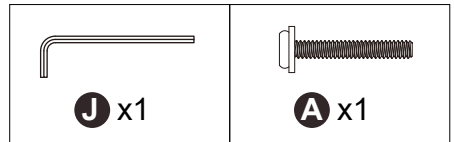
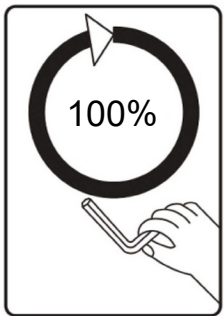

EN: **Velcro**
 ES: **Cinta de gancho y bucle**
 FR: **Velcro**

EN: **Note:** Fully tighten all screws.
 ES: **Nota:** Apriete completamente todos los tornillos.
 FR: **Remarque :** Serrez toutes les vis complètement.

Step 13

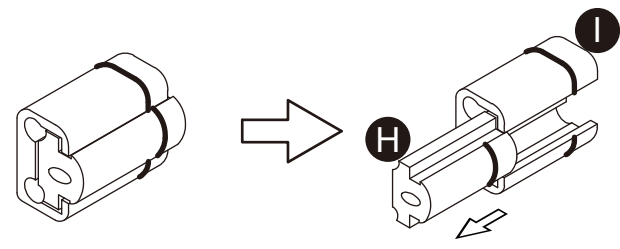
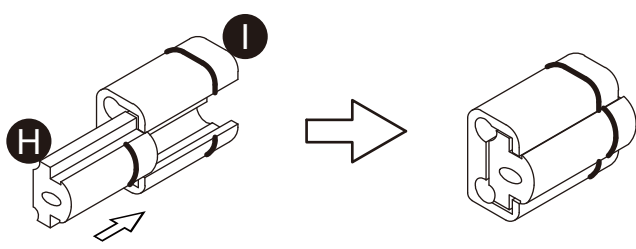
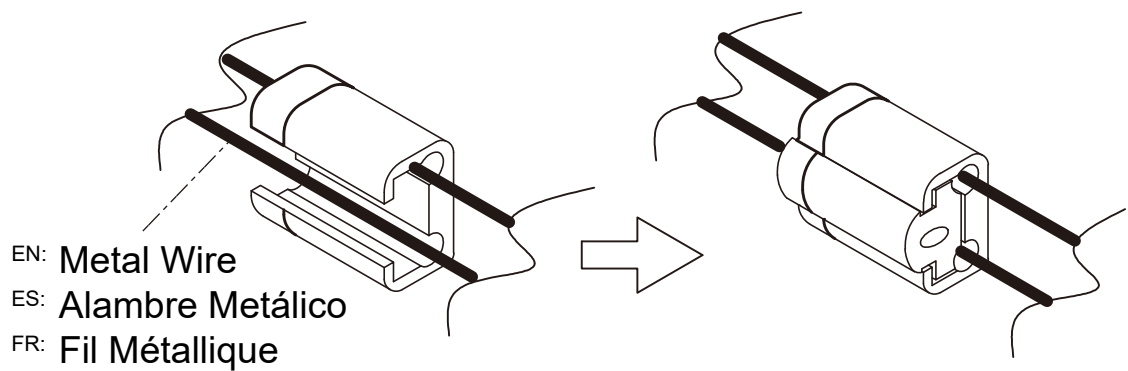

Step 14

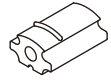
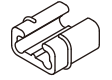
- | | | |
|---|--|--|
| 
G x2 | 
H x4 | 
I x4 |
|---|--|--|

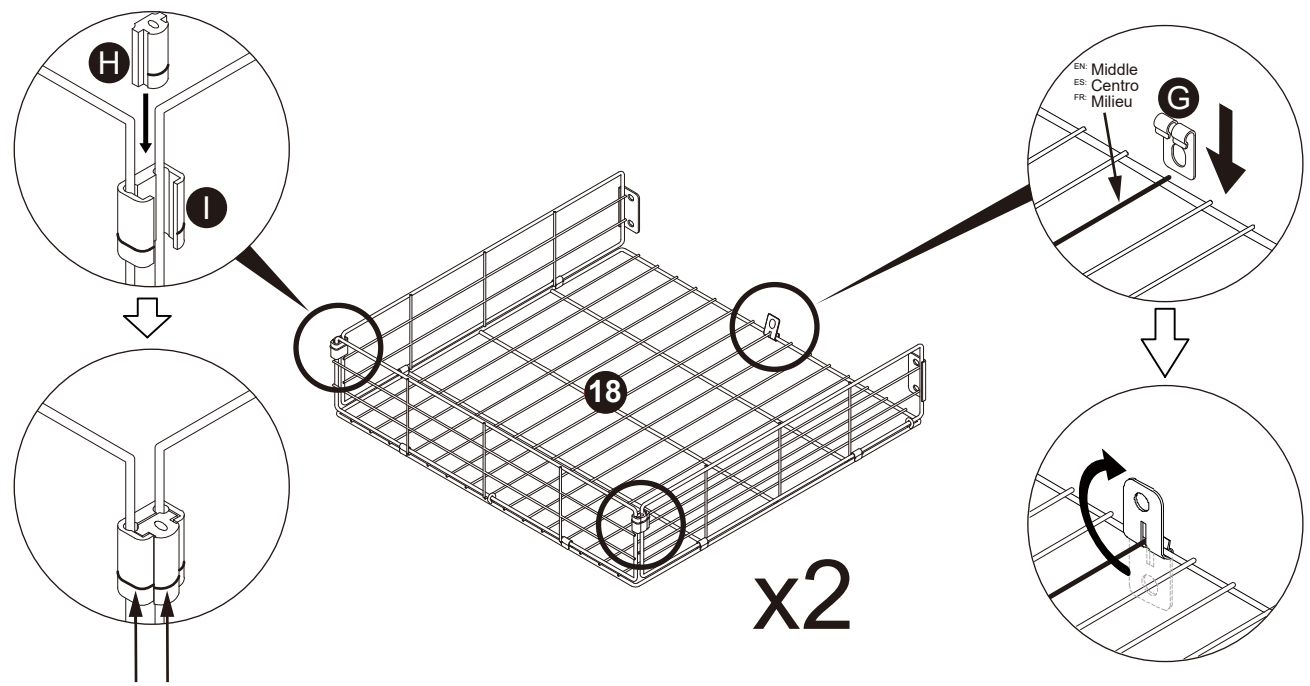

Step 15

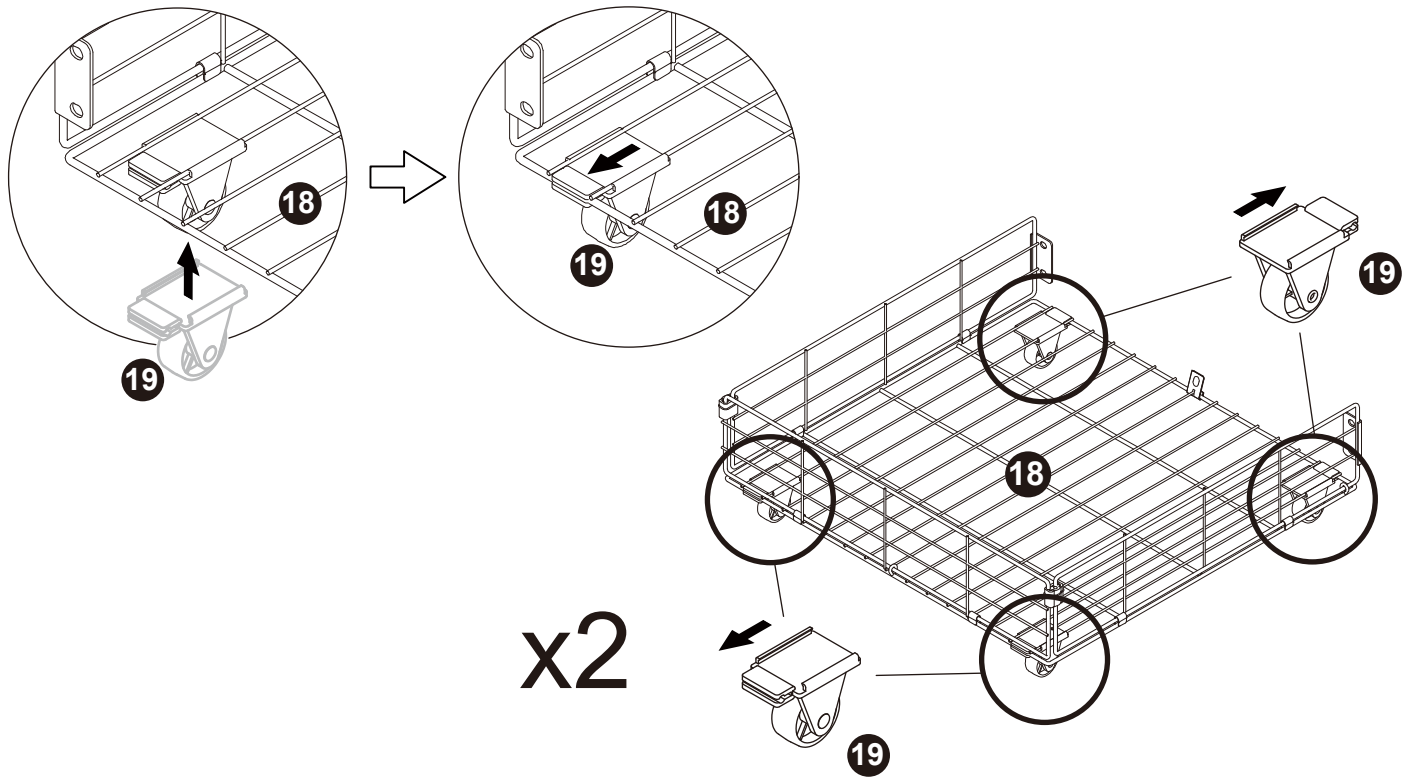

Step 16

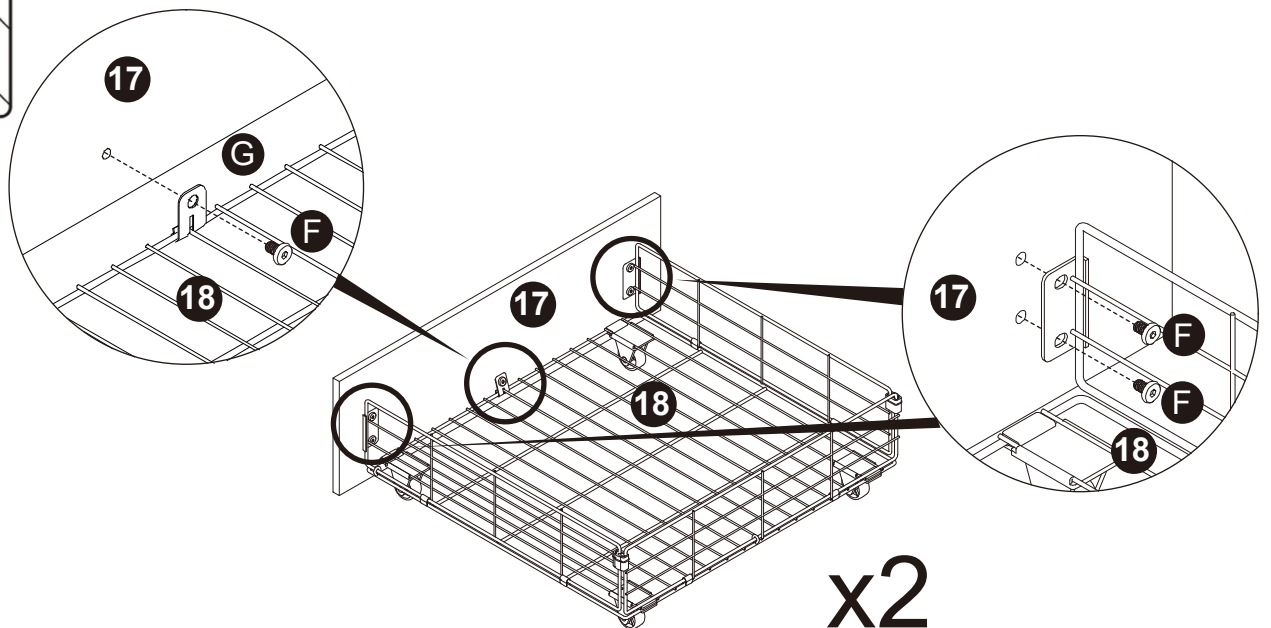
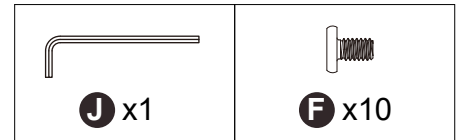
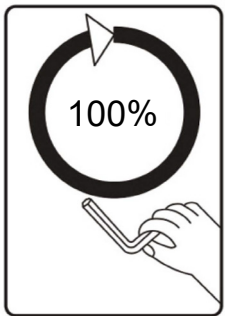

Step 17

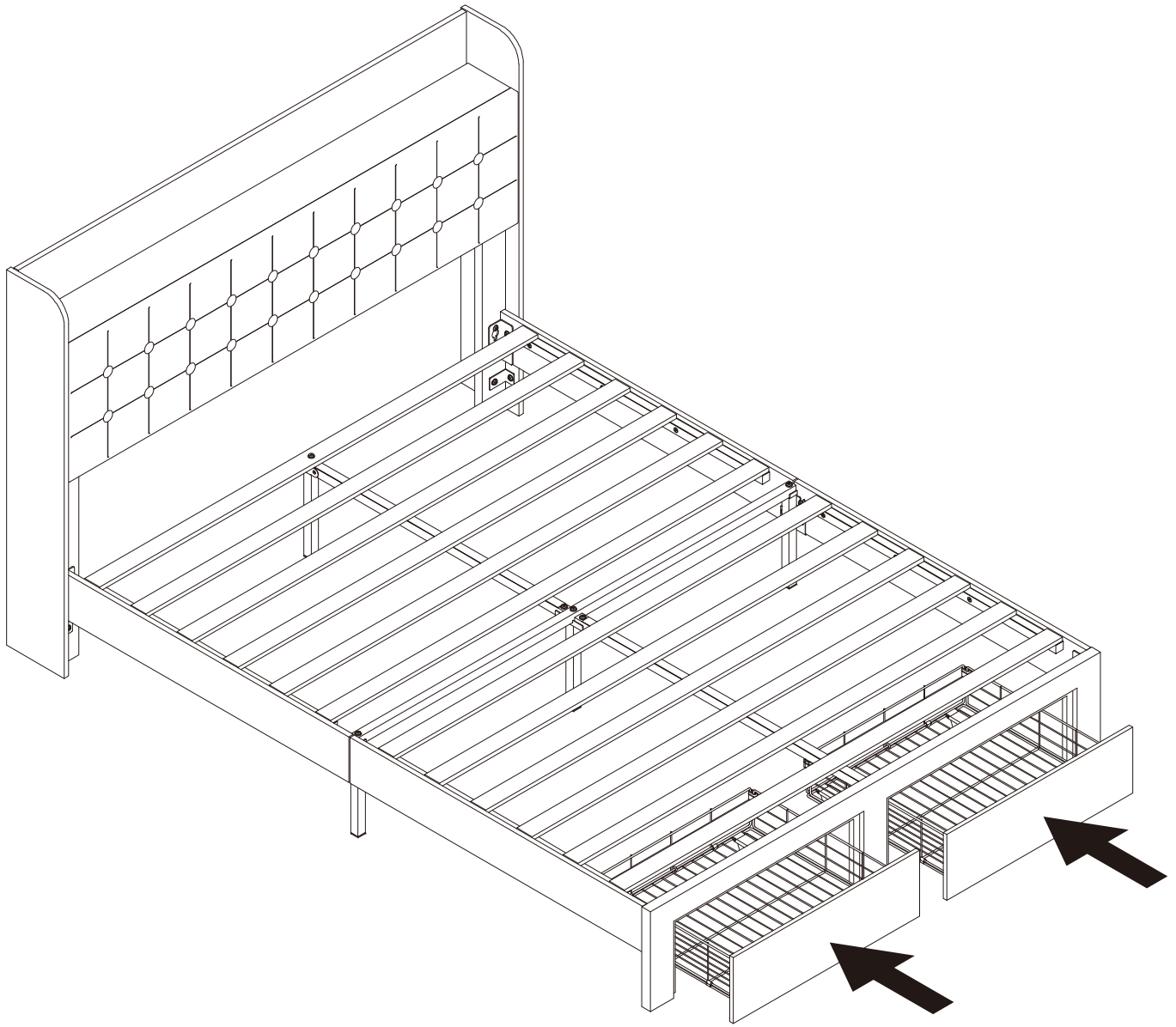

Step 18

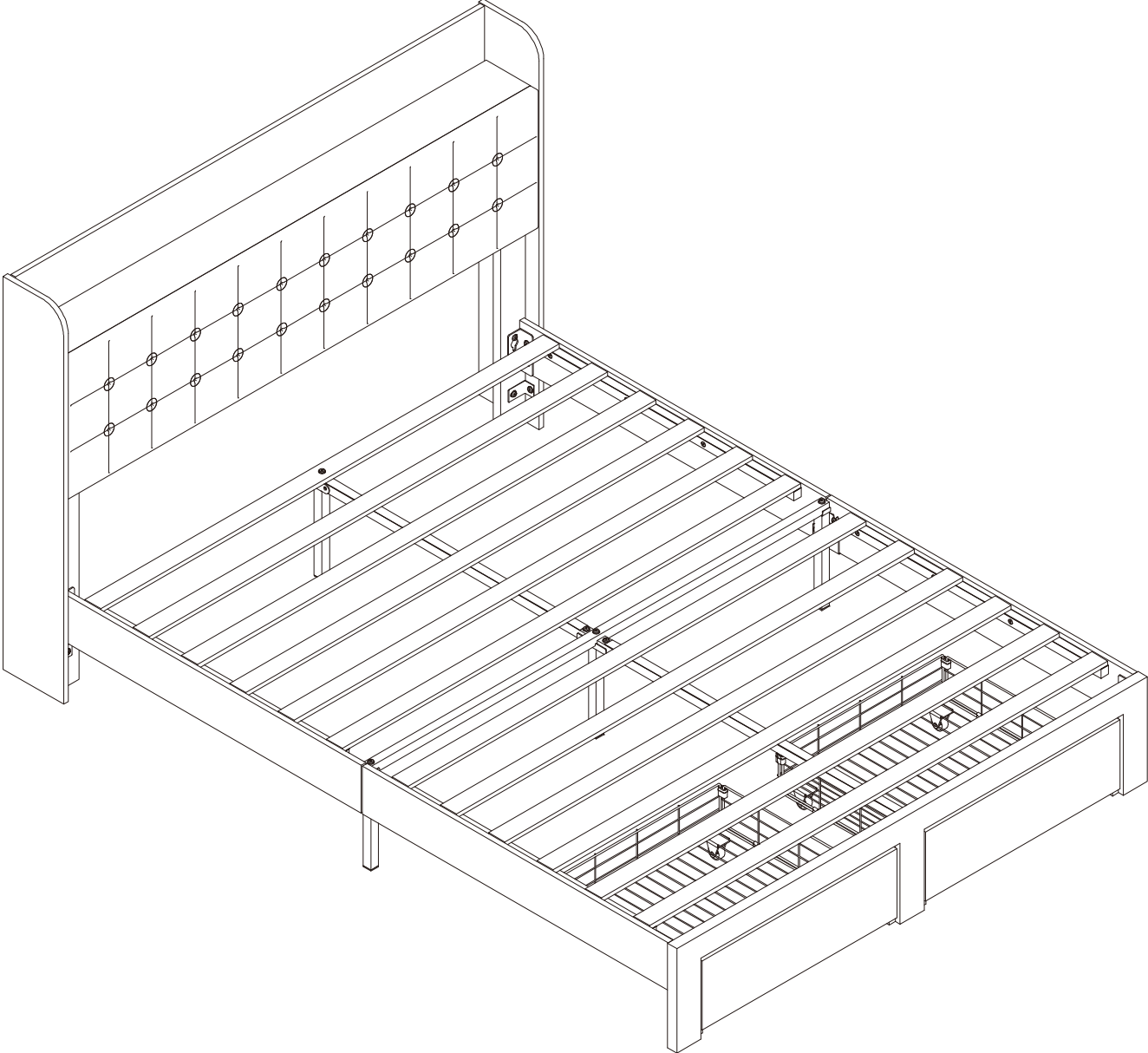

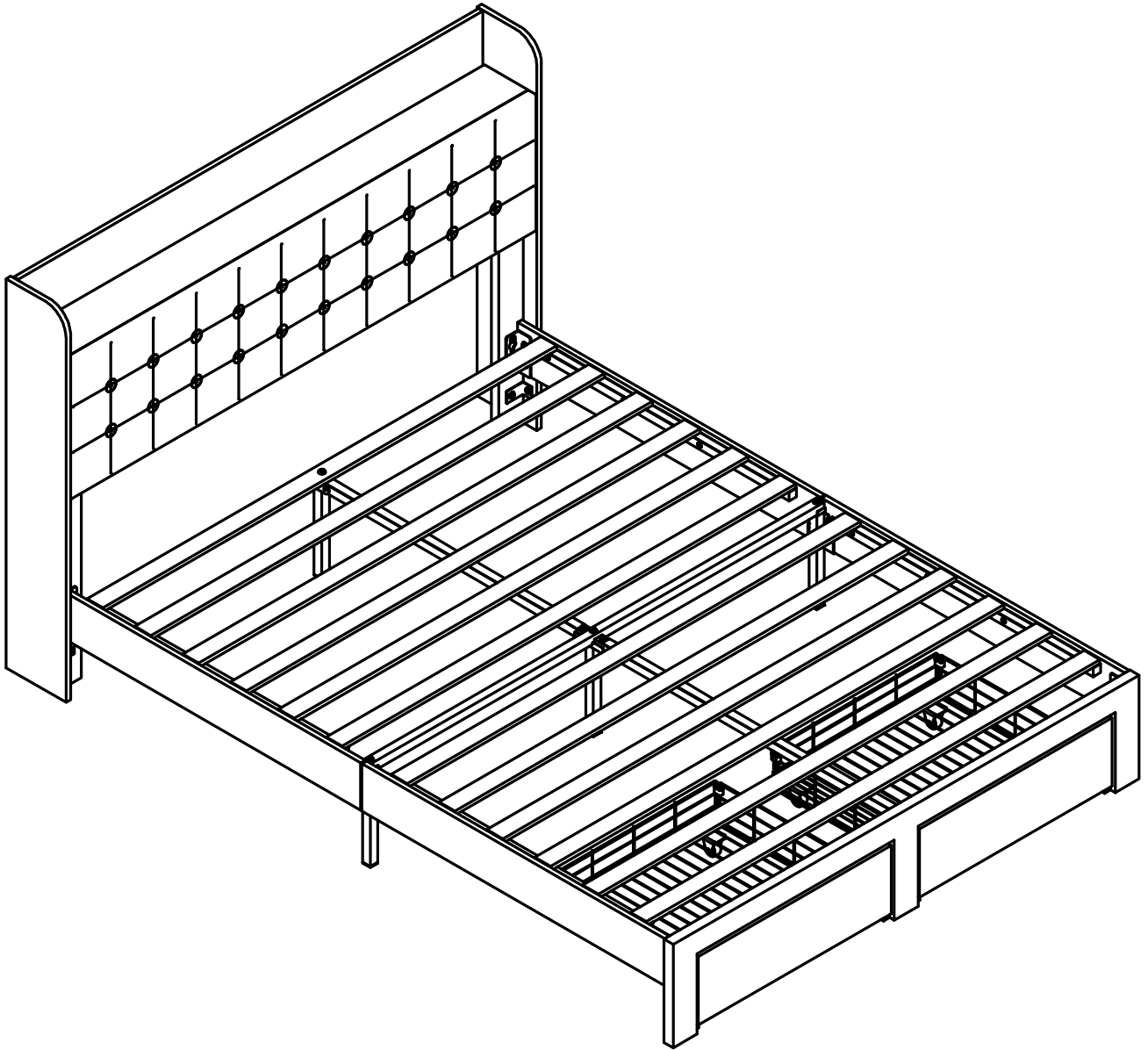

Thank you for choosing this product. We strive to provide you with the best quality products and service in the industry. Should you have any issues, please don't hesitate to contact us.