

# Assembly & Installation Instructions

**CAUTION:** Read Instructions carefully and turn electricity off at main circuit breaker panel before beginning installation.

## DHS088BB-GFCI

\*\*\*\*\*  
**WARNING** -If any Special Control Devices are used with this Fixture, Follow the instructions Carefully to assure full compliance with N.E.C. requirements. If there are any questions, contact a Qualified Electrical Contractor.  
**WARNING** -This product contains chemicals known to the State of California to cause cancer, birth defects and/or other reproductive harm. Thoroughly wash hands after installing, handling, cleaning, or otherwise touching this product.  
**CAUTION** - All glass is fragile, use care when handling Glass component(s) and or Lamp(s).  
**WARNING** -To comply with the National Electrical Code and Underwriters Laboratories requirements, when installed outdoors, or in wet locations, the edge of the wall plate coming in contact with the mounting surface, must be sealed with a latex waterproof caulking to prevent water from entering the outlet box.  
 \*\*\*\*\*

### ASSEMBLY STEPS:

### PASOS PARA ENSAMBLAR:

1. C,B \_\_\_\_\_ A
2. J \_\_\_\_\_ K 
3. D,E \_\_\_\_\_ B
4. P \_\_\_\_\_ N

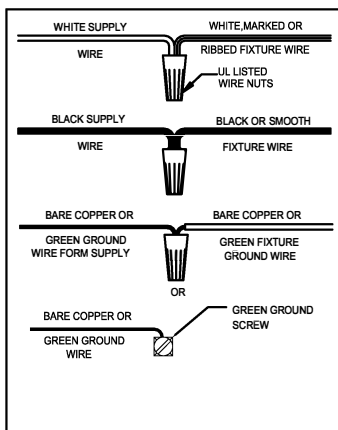
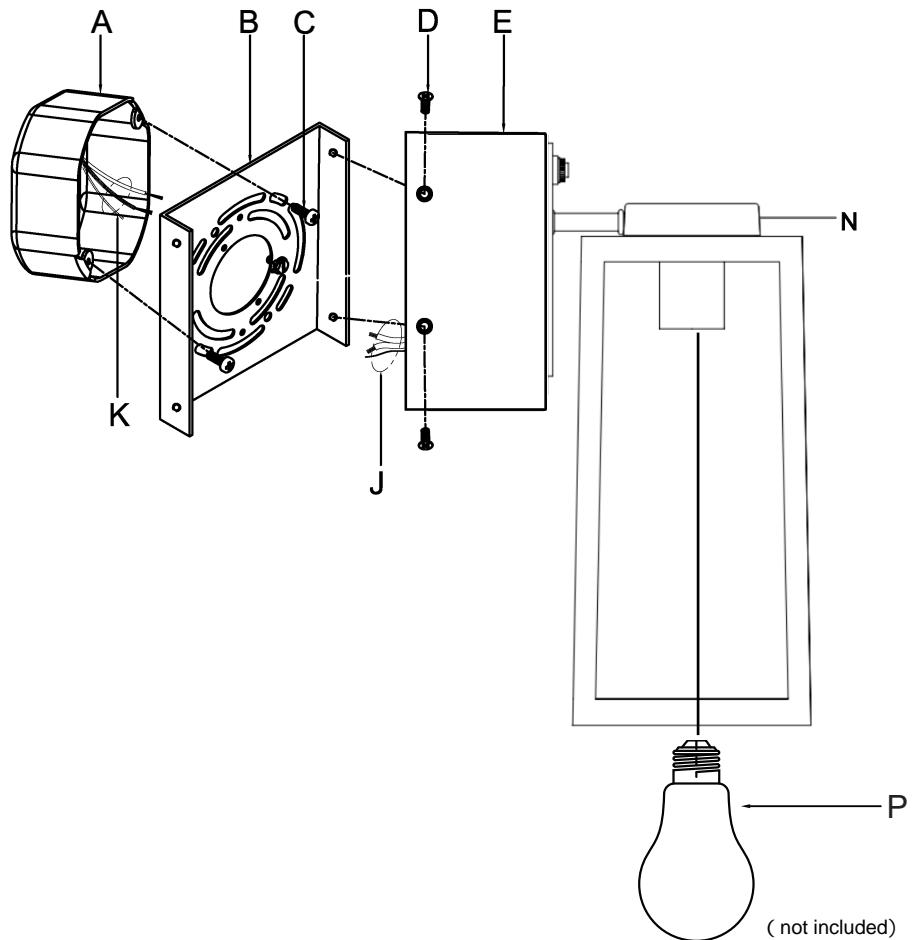

**A,P,K  
 (NOT FURNISHED)  
 (NO INCLUIDA)  
 (NON FOURNIE)**

### CAUTION

To prevent severe shock or electrocution, always turn the power OFF at the service panel before working with the wiring.

Use this GFCI receptacle with copper or copper-clad wire. Do not use it with aluminum wire

Do not install this GFCI receptacle on a circuit that powers life support equipment because if the GFCI trips, it will shut down the equipment. For installation in damp or wet locations, the GFCI receptacle must be Listed and marked as Weather Resistant (WR).

For installation in wet locations, protect the GFCI receptacle with a weatherproof cover that will keep both the receptacle and any plug dry. Must be installed in accordance with national and local electrical codes.

Tamper resistant mechanism stops access to outlet contacts unless a two-prong plug is inserted

### 1 What is a GFCI?

A GFCI receptacle is different from conventional receptacles. In the event of a ground fault, a GFCI will tip and quickly stop the flow of electricity to prevent serious injury.

Definition of a ground fault: Instead of following its normal safe path, electricity passes through a person's body to reach the ground. For example, a defective appliance can cause a ground fault.

A GFCI receptacle does not protect against circuit overload, short circuits, or shocks. For example, you can still be shocked if you touch bare wires while standing on a conducting surface such as cement or grease.

### 2 The GFCI's features

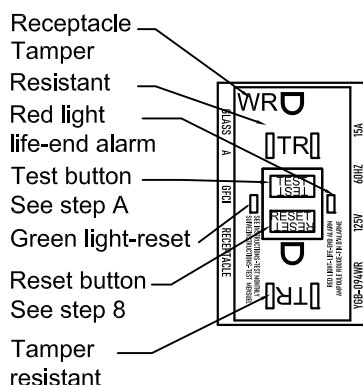

### 3 Test your work

Why perform this test?

If you miswire the GFCI it may not prevent personal injury or death due to a ground fault (electrical shock).

If you mistakenly connect the LINE wires to the LOAD terminals, the GFCI will not reset and will not provide power to either the GFCI receptacle face or any receptacles fed from the GFCI.

Procedure:

a. This GFCI is shipped from the factory in the tripped condition and cannot be reset until the Line and Load are wired correctly and power is supplied to the device. Turn the power ON at the service panel. Press the RESET button fully. If the indicator (LED) glows green, you have installed the GFCI receptacle correctly. Plug a lamp or radio into the GFCI (and leave it plugged in). Ensure that the GFCI can be tripped by pressing the TEST button. If the GFCI receptacle cannot be reset, the indicator (LED) does not glow, and there is no power in the lamp or radio, go to the Troubleshooting because LINE and LOAD wiring connections have been reversed.

b. Press the test button in order to trip the device. This should stop the flow of electricity, making the radio or lamp shut off. Note that the reset button will pop out. If the power goes off, the green indicator (LED) goes out, you have installed the GFCI receptacle correctly. To restore power, press the reset button.

c. If you installed your GFCI using step 7B, plug a lamp or radio into surrounding receptacles to see which one(s), in addition to the GFCI, lost power when you pressed the test button. Do not plug life saving devices into any receptacles that lost power. Place a "GFCI Protected" sticker on every receptacle that lost power.

d. Press the test button (then reset button) every month to assure proper operation. In case the life-end indicator (Red LED) is off the GFCI will still provide ground fault protection.

e. The GFCI includes an end-of-life monitoring function. When a GFCI receptacle is incapable of passing its internal test function (it can no longer provide ground fault protection), one of the following alarm indications will be present:

i. When the GFCI reaches the end of its' life the red indicator will turn on. The GFCI must be replaced.

ii. If there is no power output the GFCI has reached the end of its' life.

The GFCI must be replaced.

### TROUBLESHOOTING

Turn the power off and check the wire connections against the appropriate wiring diagram in step 7A or 7B. Make sure that there are no loose wires or loose connections. Also, it is possible that you reversed the line and load connections if the GFCI can not be reset and there is no power at the receptacle. Start the test from the beginning of step 8 if you rewired any connections to the GFCI. The GFCI includes an end of life monitoring function. When a GFCI receptacle is incapable of passing its internal test function (it can no longer provide ground fault protection) one of the following alarm indications will be present: When the GFCI reaches the end of its' life the red indicator will turn on. The GFCI must be replaced. If there is no power output the GFCI has reached the end of its' life. The GFCI must be replaced.