

# Claim your extended 90 day product warranty

## **NOTICE REGARDING HIGH GLOSS PROTECTIVE FOIL AND PRODUCT CARE:**

After removing the protective foil from the gloss fronts, the acrylic surface of the boards is still soft and easy to scratch. With air contact, the hygroscopic acrylic layer hardens, and the board becomes more resistant to scratches. It takes approximately 48 hours for the acrylic layer of the board to fully harden.

**DO NOT CLEAN, WIPE, OR POLISH THE  
ACRYLIC FRONTS FOR 48 HOURS AFTER  
REMOVING THE PROTECTIVE FOIL!!!**



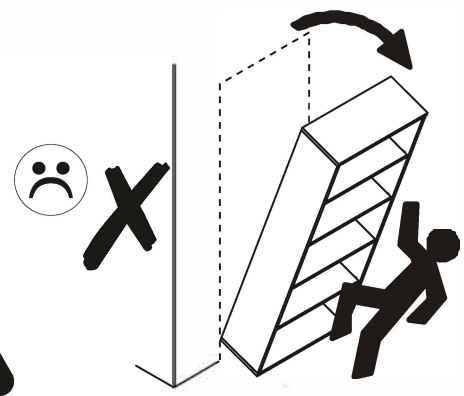
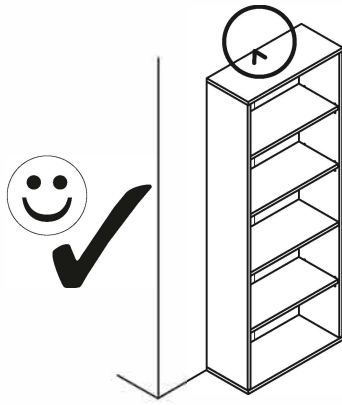

PL

UWAGA! Mebel należy trwale zamocować do ściany, aby uniknąć ryzyka związanego z przewróceniem się mebla. W paczce znajdują się elementy mocujące odpowiednie wyłącznie do ścian betonowych lub z pełnej cegły. Jeśli Twoja ściana wykonana jest z innego materiału lub nie masz pewności co do budowy tej ściany, skonsultuj w kwestii montażu ze specjalistą.

RU

нП-1МЕ4АИ-1Е! 3ТУ Ме6еАв Нео6хОАНМо есerАа нР1КрeнА5ИТb КСТеHe, \*1Т06bl \*1368)1(0Тb П-1КСОВ, СБ530ННbХ С neпeeopОТОМ Ме6еА1-1, 8 наКeTe НОХОА5ТС51 1<пeнv1reAbHbl8 3А5М9НТb1, КОТОПb1S нОАХОА5ИТ 1-1КСА1О4НТ8АВНОК 6eТОНОБbМ СТ5НОМ Н4Н 18 USAOro 1G1pm1-1a. ЕСАН СТ5НО \*13ДТОБА8НО JБ АРyрoгo MOT9p\*10АO J1A1 Bbl He yeepHbl OTHOCИT8АВНО СТО8НИ5И СТ5Нbl, нпOKOHCYAbTHпyиllrecb OTHOCИT8АВНО МОHTЦДКО e o cнeУOHAOCTOM.

I.

ATTENZIONE! Il mobile deve essere permanentemente fissato alla parete per evitare i rischi derivanti da un ribaltamento del mobile. La confezione contiene solo elementi di fissaggio adatti per pareti in calcestruzzo o in laterizio pieno. Se la vostra parete è realizzata in materiale diverso o avete dubbi sulla costruzione della parete, consultare uno specialista per un montaggio corretto.

EN.

**WARNING!** To prevent this furniture from tripping over, fix it to the wall permanently. The package includes fastening elements only suitable for concrete or full-brick walls. If your wall is made of a different material or you are unsure as to the construction of the wall, please consult a specialist regarding installation.

FR

ATTENTION! Ce meuble doit être fixé en permanence au mur pour éviter les risques de chute. L'ensemble comprend des moyens de fixation adaptés uniquement aux murs de béton ou de brique. Si votre mur est fait d'un matériau différent ou si vous êtes incertain quant à la construction du mur, consultez un spécialiste.

HR

NAPOMENA! Namjestaj mora biti trajno pričvršćen za zid, kako bi se izbjegao rizik a njegova prevrtanja. U paketu se nalaze elementi za pričvršćivanje prikladni isključivo za betonske zidove ili punu ciglu. Ako je Vas zid izrađen a drugog materijala ili niste sigurni a cega je napravljen Vas zid, konzultirajte se sa stručnjakom u vezi sa montažom.

CN.

D.

ACHTUNG! Um alle mit dem Umkippen des Mobels verbundenen Risiken auszuschließen, muss das Möbel fest an der Wand verankert werden. Die im Paket enthaltenen Beschläge für die Wandbefestigung sind ausschließlich für Wände aus Beton oder Vollziegel geeignet. Sollten die heimischen Wände aus anderem Baumaterial bestehen oder sollte es Zweifel in Hinsicht auf dieses Baumaterial geben, bitte eine Fachkraft zu Rate ziehen.

HU.

FIGYELEM! Rogzftse a butorokot a falhoz, hogy elkerülje a butor felborulásának kockázatát. A keszletben kizárólag beton- vagy teglafalhoz használatú kotoelemek találhatók. Ha a fal más anyagból készült, vagy ha nem tudja, milyen falak találhatók otthonában, forduljon szakemberhez.

CZ.

POZOR! N6bytek je nutné pevně připevnit ke zdi, abychom se vyhnuli riziku spojenému s jeho převrnutím. V balíčku se nacházejí připevňovací prvky vhodné výhradně do betonových zdí nebo zdí z plných cihel. Pokud jsou Vase zdi zhotoveny z jiného materiálu nebo si nejste jejich konstrukci jisti, konzultujte otázku montáže se specialistou.

E

¡ATENCIÓN! El mueble debe ser fijado permanentemente a la pared para evitar el riesgo relacionado con el vuelco del mueble. En el paquete hay elementos de fijación adecuados solo para paredes de hormigón o de ladrillo entero. Si su pared está hecha de otro material o no está seguro sobre la construcción de esta pared, consulte el montaje con un especialista.

SK.

POZOR! N6bytok musí byť trvalo pripevnený k stene tak, aby sa zamedilo riziku prevrátenia. V balíku sú nachádzajúce upevňovacie komponenty výlučne pre betónové steny alebo steny z plnej tehly. Ak je Vasa stena z iného materiálu alebo ak si nie ste istí, z čoho je stena vyhotovená, vyžadujte si odbornú pomoc.

SLO.

POZOR! Pohistvo trajno pritrdite no steno, do preprecite tveganje, da se prevrne. V paketu so prilrdilni elementi, ki so ustremi izključno za betonske stene in za stene iz pains opeke. Če je vasa steno izdelana iz drugih materialov ali niste gotovi glede konstrukcije stene, se o montaji posvelujte s strokovnjakom.

PL

UWAGA! Mebel należy trwale zamocować do ściany, aby uniknąć ryzyka związanego z przewróceniem się mebla. W paczce znajdują się elementy mocujące odpowiednie wyłącznie do ścian betonowych lub z pełnej cegły. Ponieważ rodzaj mocowania należy odpowiednio dobrać do rodzaju ściany, dobierz właściwe do Twojego rodzaju ściany.

SK.

POZOR! Nabytok musí byť trvalo pripevnený k stene tak, aby sa zamedilo riziku prevrátenia. Balík neobsahuje upevňovacie skrutky, pretože typ upevnenia je treba vybrať podľa typu steny. Vyberte typ vhodný pre Vasu stenu.

FR.

ATTENTION! Ce meuble doit être fixé en permanence au mur pour éviter les risques de chute. Les vis de fixation ne sont pas livrées car le type de fixation doit être choisi en fonction du type de mur. Sélectionnez les fixations adaptées au mur.

D.

ACHTUNG! Um alle mit dem Umkippen des Mobels verbundenen Risiken auszuschließen, muss das Möbel fest an der Wand verankert werden. Beschläge für die Wandbefestigung sind nicht beige packt, da diese von der jeweiligen Wandbeschaffenheit abhängig sind. Bitte solche Befestigungsschläge wählen, die für die heimischen Wände geeignet sind.

EN.

**WARNING!** To prevent this furniture from tripping over, fix it to the wall permanently. Fixing devices are not included since different wall materials require different types of fixing devices. Please make sure you chose the correct ones for your type of wall.

I.

ATTENZIONE! Il mobile deve essere permanentemente fissato alla parete per evitare i rischi derivanti da un ribaltamento del mobile. La confezione non include le viti di fissaggio, in quanto il tipo di fissaggio deve essere scelto in base al tipo di parete. Utilizzare viti appropriate in base al materiale della parete.

SLO.

POZOR! Pohistvo trajno pritrdite na steno, da preprecite tveganje, da se prevrne. V paketu ni prilrdilnih vijakov, saj je treba način pritrditve ustrezno izbrati glede na vrsto stene. Izberite način, ki je ustrezen za vasa steno.

RU.

нП-1МЕ4АИ-1Е! 3рy Ме6еАв Нео6хОАИМО ссerАа нР11Крeн1Тb КСТеHe, \*нo6bl 11136e)аТb п11КСОВ, СБ53аННbХ С neпeeopОТОМ Ме6e1111. B наКeRe НeТ Крeнe)(НbХ БИИТОВ, pOTOMY 4TO TИлл КрeнeИИИ4 АOИ)(eH 6b1Тb Bbl6паH B COOTBeTCTBИИ c TИллOM creHbl. Bbl6eп111re, нo)l(aflycra, нпаБИИИbHble БИИИТb KBaвe CTeHe.

CZ.

POZOR! Nabytek je nutné pevně připevnit ke zdi, abychom se vyhnuli riziku spojenému s jeho převrnutím. Součástí balení nejsou připevňovací šrouby, protože způsob připevnění je nutné zvolit podle druhu steny. Vyberte správný pro Vas typ steny

HU.

FIGYELEM! Rogzftse a butorokot a falhoz, hogy elkerülje a butor felborulásának kockázatát. A keszletben nem találhatók rogzftcsavarok, mivel a rogzftes Upusa a fal Upusat6 fugg. Valassza ki a fal trpusanak megfelel6 k6telemeket

HR.

NAPOMENA! Namjestaj mora biti trajno pričvršćen za zid, kako bi se izbjegao rizik a njegova prevrtanja. U paketu nema vijaka za pričvršćivanje, jer se vrsta montaze mora prilagoditi vrsti zida. Odaberite pravu vrstu prema Vasoj vrsti zida.

E

¡ATENCIÓN! El mueble debe ser fijado permanentemente a la pared para evitar el riesgo relacionado con el vuelco del mueble. En el paquete no hay tornillos de fijación, ya que se debe elegir el tipo de fijación adecuado para el tipo de pared. Elija el apropiado para su tipo de pared.

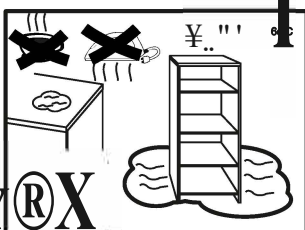
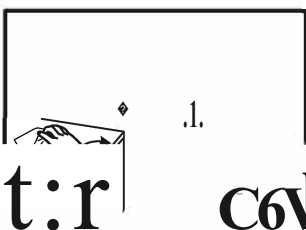
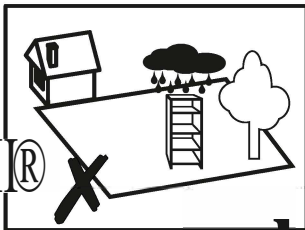
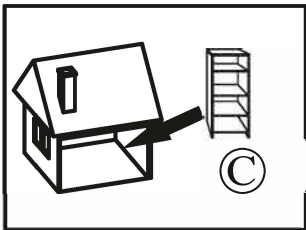
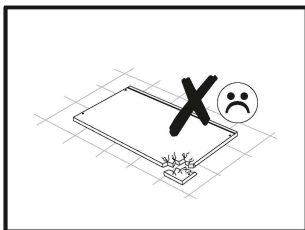
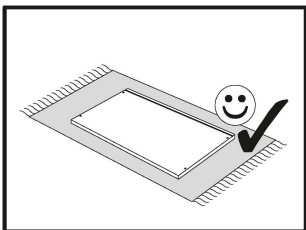
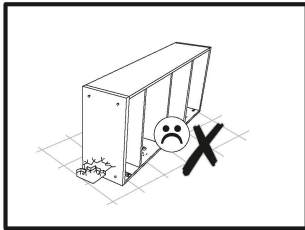
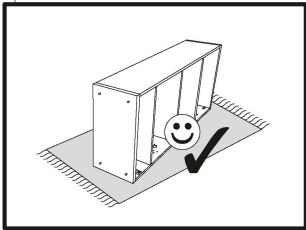
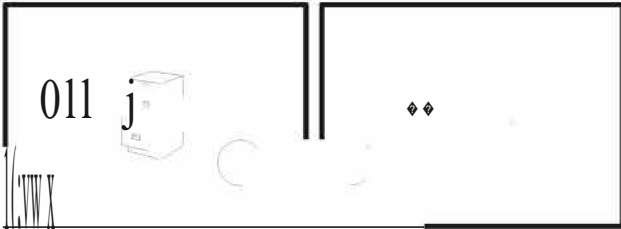
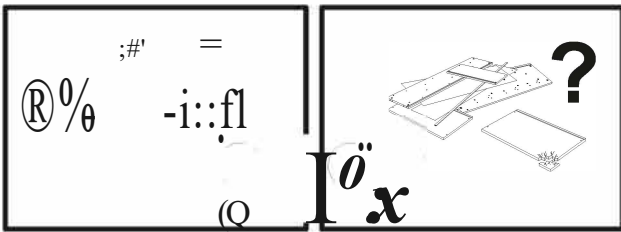

**D: ALLGEMEINE HINWEISE FÜR MOSEL AUS HOLZ UND HOLZWERKSTOFFE: MELAMIN, LAMINAT, ARMATURENBRETT**  
Zu reinigen, verwenden Sie ein feuchtes Tuch. Verwenden Sie nur Wasser oder ein mildes Reinigungsmittel. Wischen Sie mit einem Tuch trocken.

**GB: GENERAL INSTRUCTIONS FOR FURNITURE OF WOOD AND WOOD MATERIALS: MELAMINE, LAMINATE, DASHBOARD**  
To clean, use a damp cloth. Use only water or a mild detergent. Wipe dry with a cloth.

**ES: INSTRUCCIONES GENERALES PARA MUEBLES DE MADERA Y MATERIALES: MELAMINA, LAMINADO, TABLERO DE INSTRUMENTOS**  
Para limpiar, utilice un paño húmedo. Utilice solo agua o un detergente suave. Seque con un paño

**FR: INSTRUCTIONS GÉNÉRALES DE MEUBLES DE MATÉRIEL/AUX DE BOIS ET: MELAMINES, STRATIFIÉS, TABLEAU DE BORD**  
Pour nettoyer, utilisez un chiffon humide. d'eau ou d'un détergent doux. Essuyer avec un chiffon.

**CZ: VŠEOBECNÉ POKYNY PRO NABÝTEK Z DŘEVĚ A DŘEVĚNÝCH MATERIÁLŮ; MELAMINE, LAMINÁT, DASHBOARD**  
K čištení použijte vlhký hadřík. Používejte pouze vodu nebo jemným čisticím prostředkem. Vytríte do sucha hadříkem.

**PL: OGÓLNE INSTRUKCJE DOTYCZĄCE MEBLI Z DREWNA ORAZ MATERIAŁÓW DREWNOPOCHODNYCH: MELAMINA, LAMINAT, OKLEINA**  
Do czyszczenia należy używać wilgotnej ściereczki. używać wyłącznie wody lub delikatnego detergentu. Wycierać do sucha ściereczką.

**HU: A BUTOR ALTALANOS FAANYAGOK ÉS FAPAR/ANYAGOK: MELAMIN, LAMINÁT, MUSZERFAL**  
A tisztításhoz használjon egy nedves ruhával. Csak vizet vagy enyhe tisztítószerrel. Toroid szárazra egy ronggyal.

**HU: A BUTOR ALTALANOS FAANYAGOK ÉS FAPAR/ANYAGOK: MELAMIN, LAMINÁT, MUSZERFAL**  
A tisztításhoz használjon egy nedves ruhával. Csak vizet vagy enyhe tisztítószerrel. Toroid szárazra egy ronggyal.

**SK: VŠEOBECNÉ POKYNY PRO NABÝTEK Z DŘEVĚ A DŘEVĚNÝCH MATERIÁLŮ; MELAMINE, LAMINÁT, DASHBOARD**  
Na čistenie použite vlhku handričku. používať iba vodu a/bo jemným čističím prostriedkom. Vytrite do sucha handrickou.

**RU: ОБЩИЕ ПОДСОУЩЕ ПОКАЗАНИЯ ПО НАБЫТИЮ ИЗ ДРЕВА И ДРЕВЯНЫХ МАТЕРИАЛОВ: МЕЛАМИН, ЛАМИНАТ, ДАШБОРД**  
[In Russian text describing cleaning instructions]

**IT: /STRUZZIONI GENERALI PER MOBILI DI LEGNO E LEGNO MATERIAL: MELAMIN/CO, LAMINATO, CRUSCOTTO**  
Per la pulizia, utilizzare un panno umido. Utilizzare solo acqua o un detergente neutro. Asciugare con un panno.

**RO: INSTRUCȚIUNI GENERALE DE MOBILIER DE LEMNOASA ? MATERIALE LEMNOASE: PAL, LAMINAT, TABLOU DE BORD**  
Pentru a curăța, folosiți o cârpă umedă. Folosiți numai apă sau un detergent slab. Stergeți cu o cârpă.

**TR: AHŞAP VE AHŞAP MALZEMELERİN MOBİL YAKI:İN GENEL BİLGİLER: MELAMIN, LAMINAT, PANEL**  
Temizlemek için, nemli bir bez kullanın. Sadece su veya hafif bir deterjan kullanın. Bir bez ile kurulayın.

**NL: ALGEMENE RICHTLIJNEN VOOR MEUBELEN VAN HOUT EN HOUTPRODUCTEN MATERIALEN: MELAMINE, LAMINAAT, DASHBOARD**  
Schoon te maken, gebruikt u een vochtige doek. Gebruik alleen water of een mild schoonmaakmiddel. Veeg met een doek droog.

**PL: Komplementowanie akcesorii oraz proces pakowania odbywa się pod nadzorem kontroli jakości oraz monitoringu.**

**EN: Complementing the accessories and the packaging process is carried out under the supervision of quality control and monitoring.**

**DE: Die Ergänzung des Zubehörs und des Verpackungsprozesses erfolgt unter der Aufsicht der Qualitätskontrolle und -überwachung.**







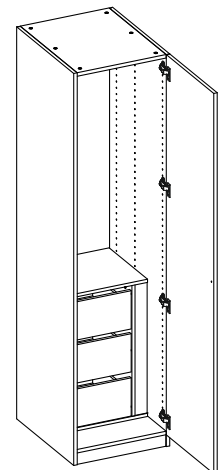
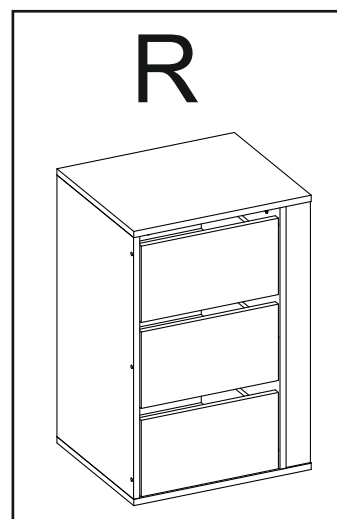
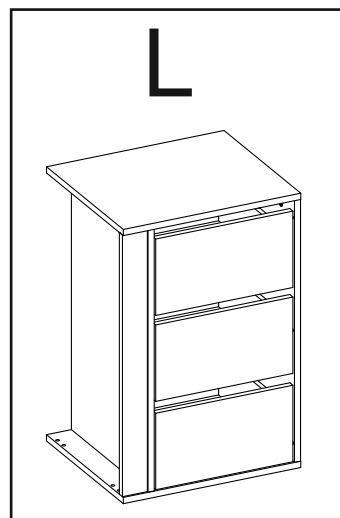
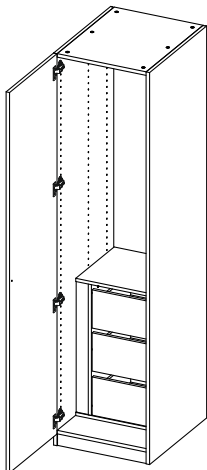
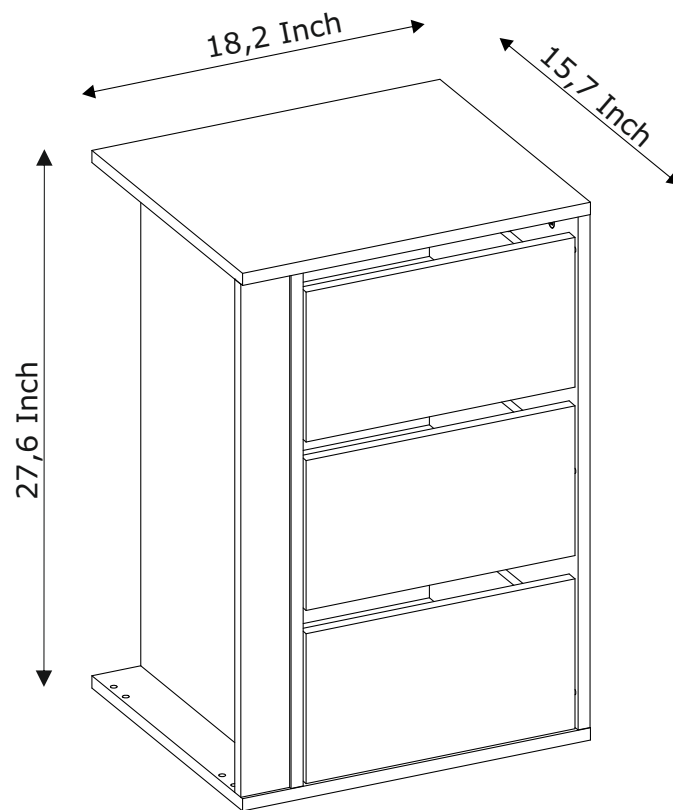

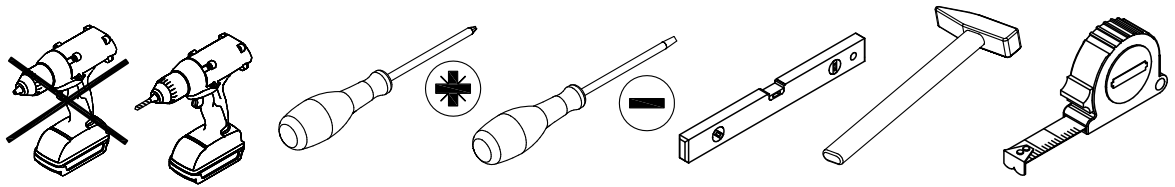
**FR: Le complément des accessoires et du processus d'emballage s'effectue sous la supervision d'un contrôle et d'une surveillance de la qualité.**

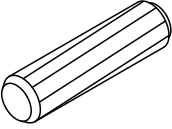
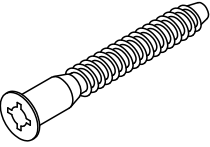

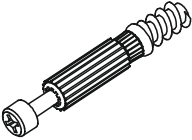
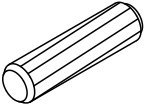
# 3 drawers

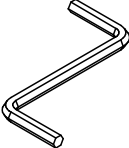

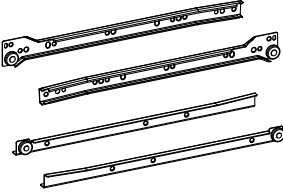

|  |   |  |   |
|--|---|--|---|
| <p>A x 8</p>  <p>8x35</p>     | <p>B x 13</p>  <p>7x50</p>   | <p>C x 4</p>  <p>15x12</p> | <p>D x 16</p>  <p>5x44</p> |
| <p>E x 12</p>  <p>6x30</p>   | <p>G x 12</p>  <p>6,3x13</p> | <p>I x 21</p>  <p>3x20</p> | <p>N x 1</p>  <p>4 mm</p> |
| <p>Q x 12</p>  <p>15x10</p> | <p>R x 12</p>  <p>20</p>   | <p>U x 3</p>  <p>350</p> | <p>Z x 10</p>  <p>20</p> |

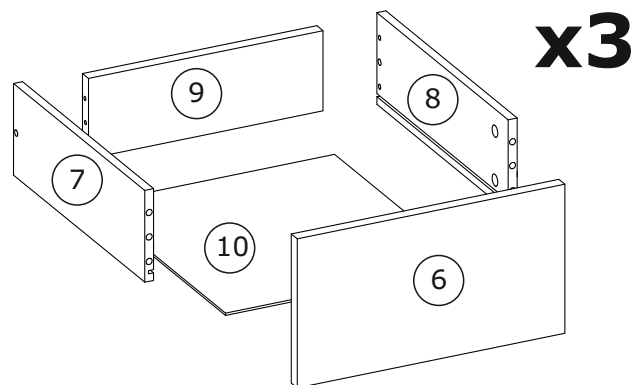
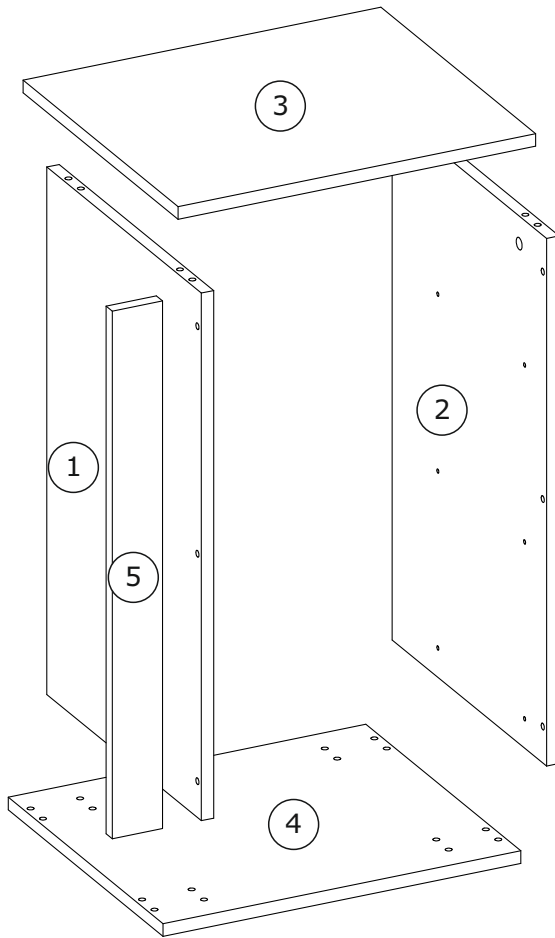

# BOX 1/1:

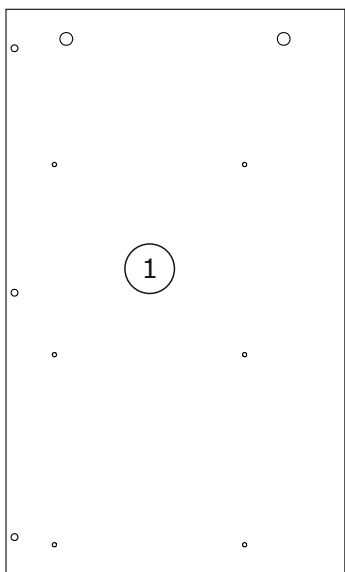

26 19/64 x 15 45/64 x 5/8 Inch

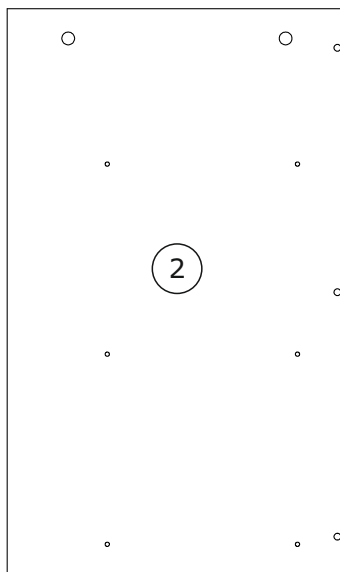

26 19/64 x 15 45/64 x 5/8 Inch



26 19/64 x 2 9/16 x 5/8 Inch

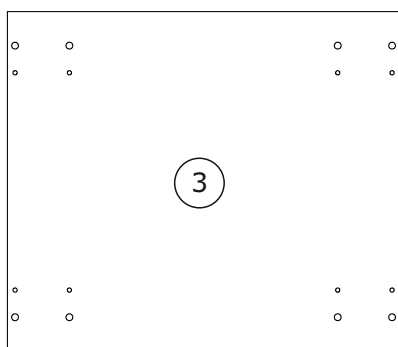

18 3/16 x 15 3/4 x 5/8 Inch

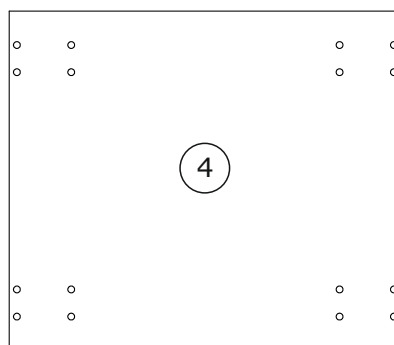

18 3/16 x 15 3/4 x 5/8 Inch

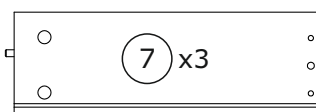

13 25/32 x 4 23/32 x 15/32 Inch

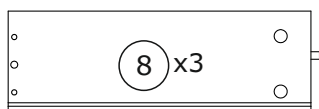

13 25/32 x 4 23/32 x 15/32 Inch

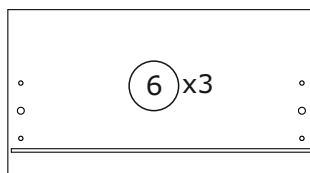

14 1/16 x 7 43/64 x 5/8 Inch

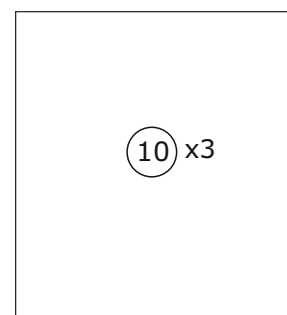

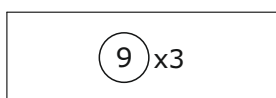

12 3/4 x 14 1/16 x 1/8 Inch

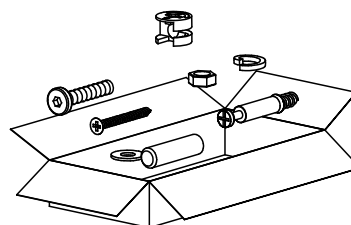

12 21/64 x 4 9/64 x 15/32 Inch



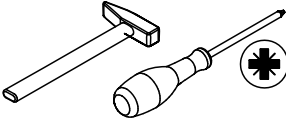

1

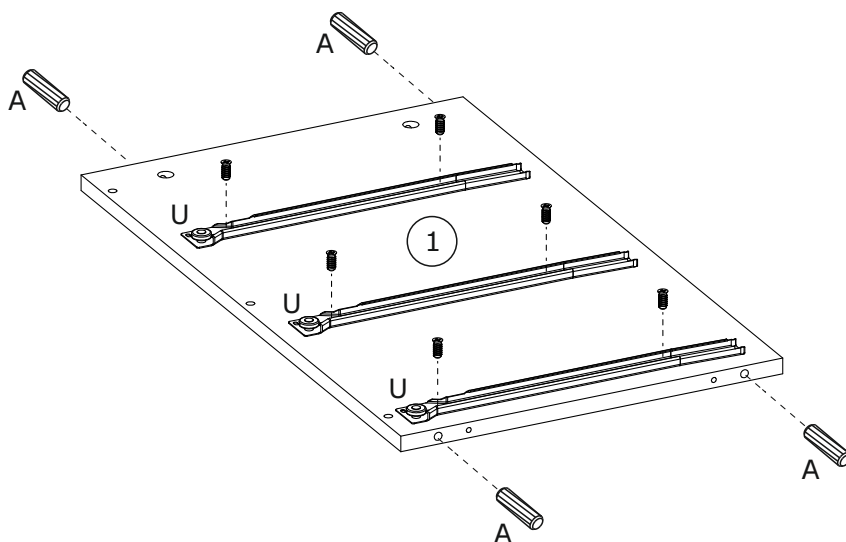
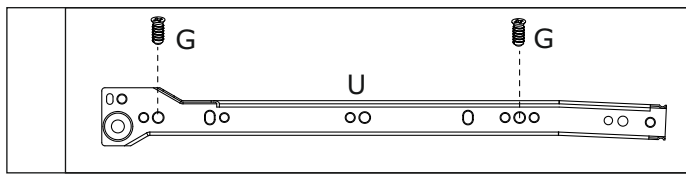
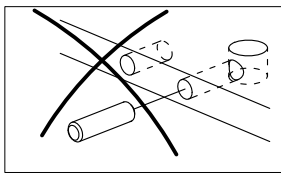
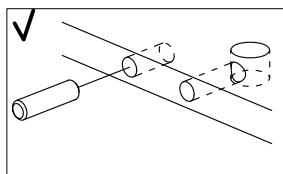
|  |  |   |   |
|--|--|---|---|
| A x 4<br><br>8x35 | G x 6<br><br>6,3x13 | U x 3<br><br>350 |  |
|--|--|---|---|

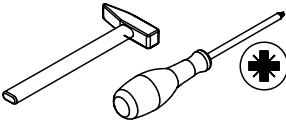

2

|  |  |   |   |
|--|--|---|---|
| A x 4<br><br>8x35 | G x 6<br><br>6,3x13 | U x 3<br><br>350 |  |
|--|--|---|---|

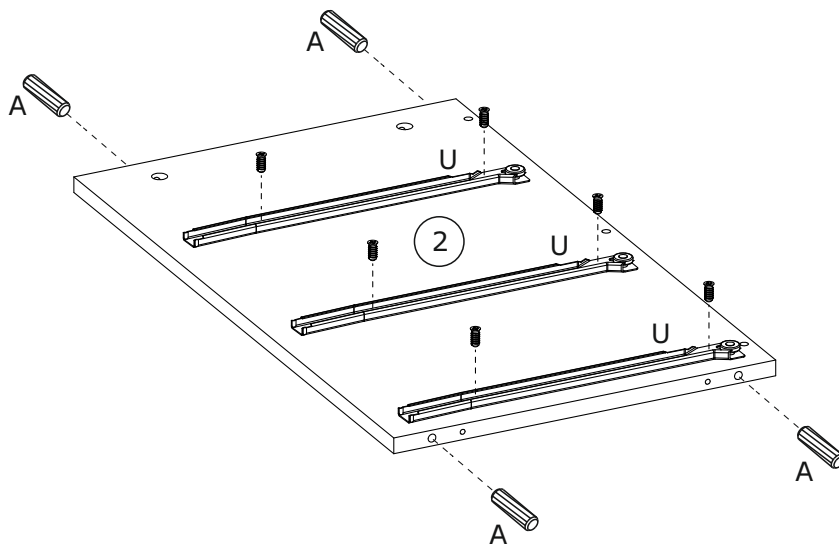
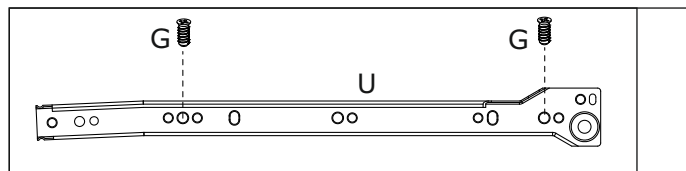
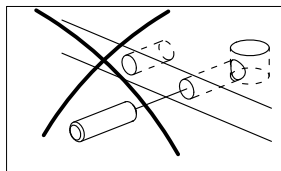
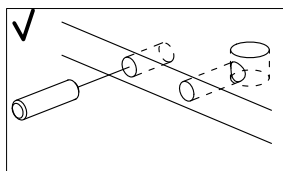

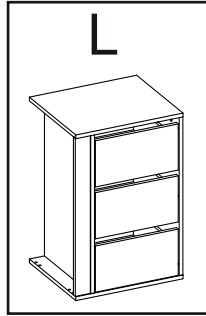
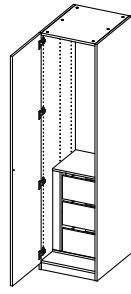

3

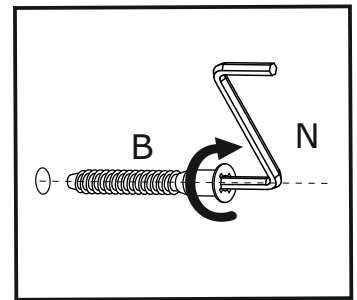
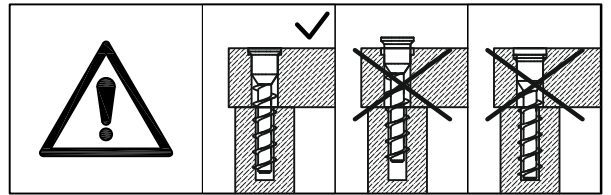
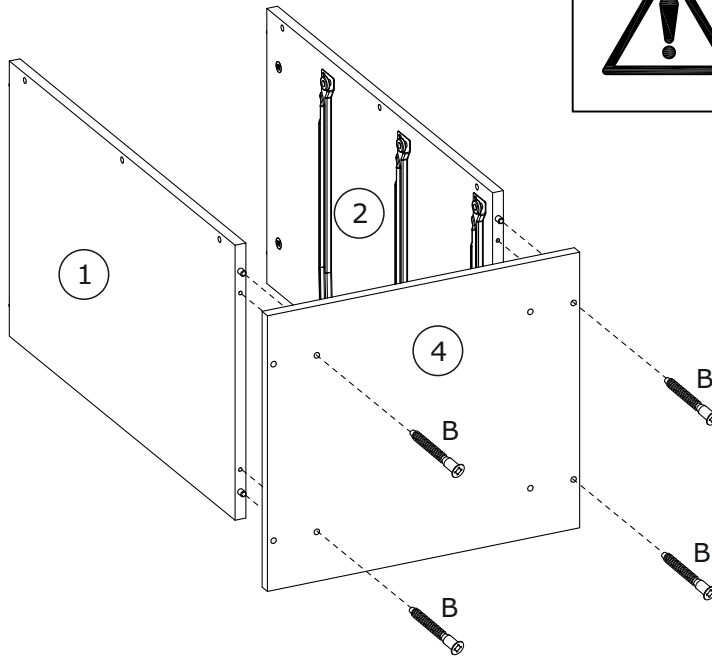
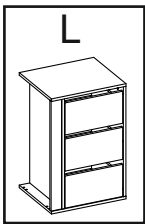
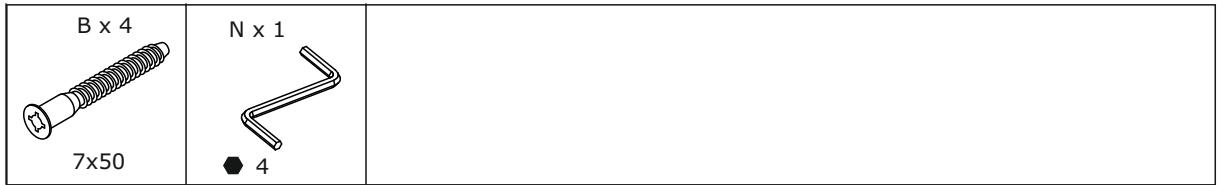

4

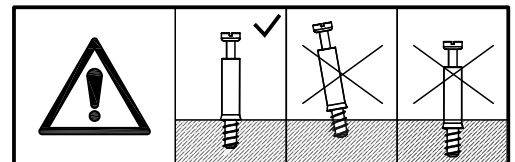
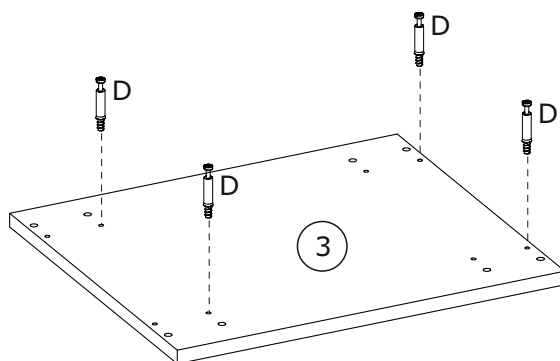
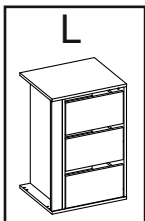

5

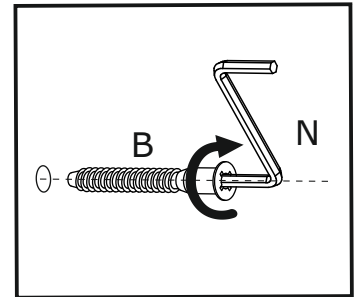
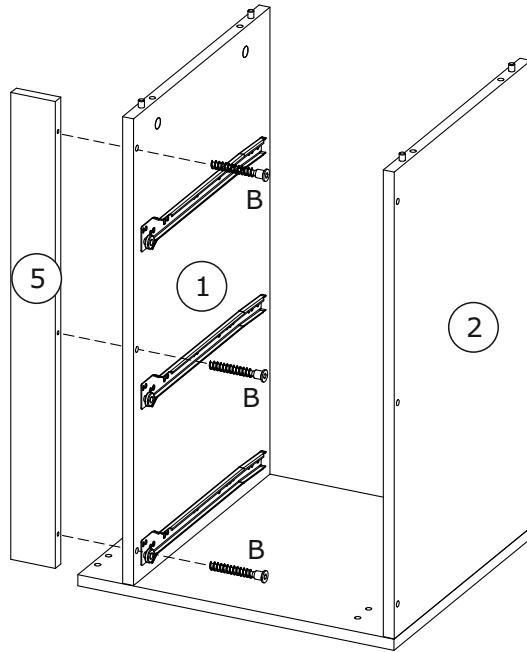
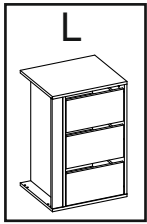
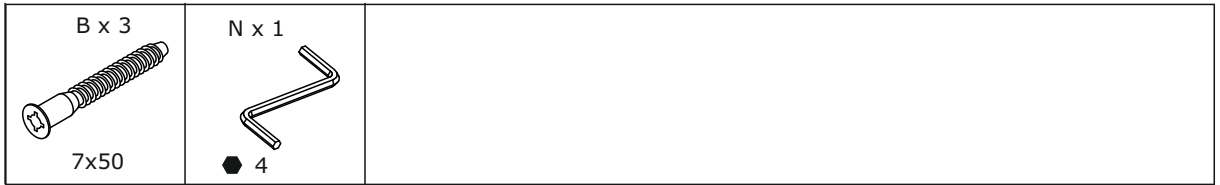

6

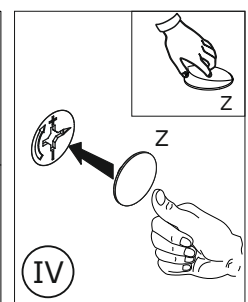
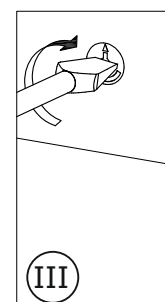
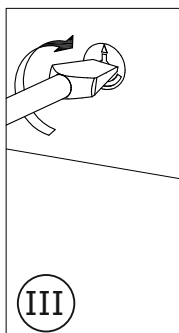
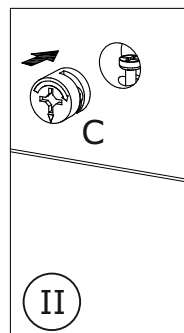
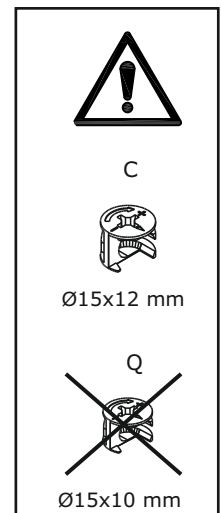
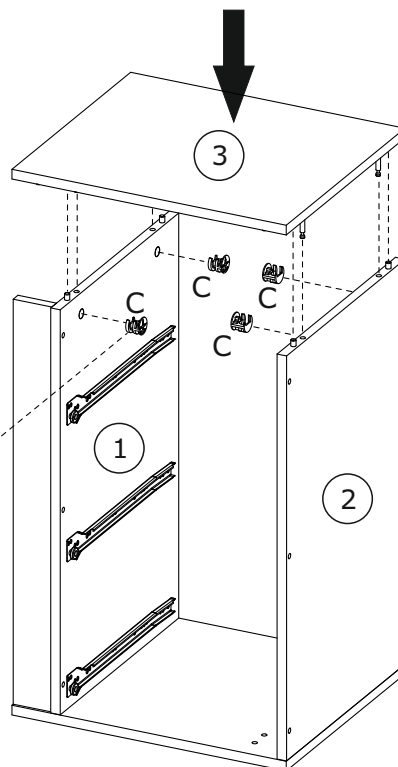
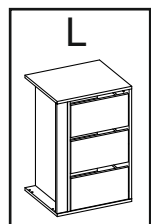
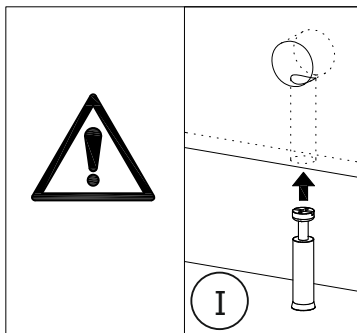

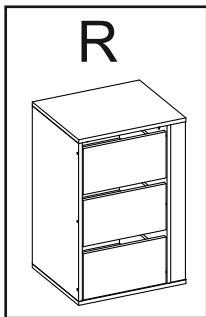
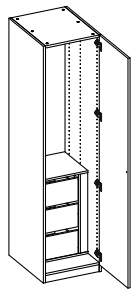

7

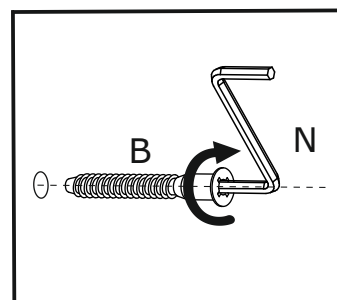
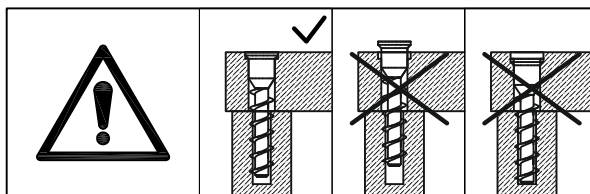
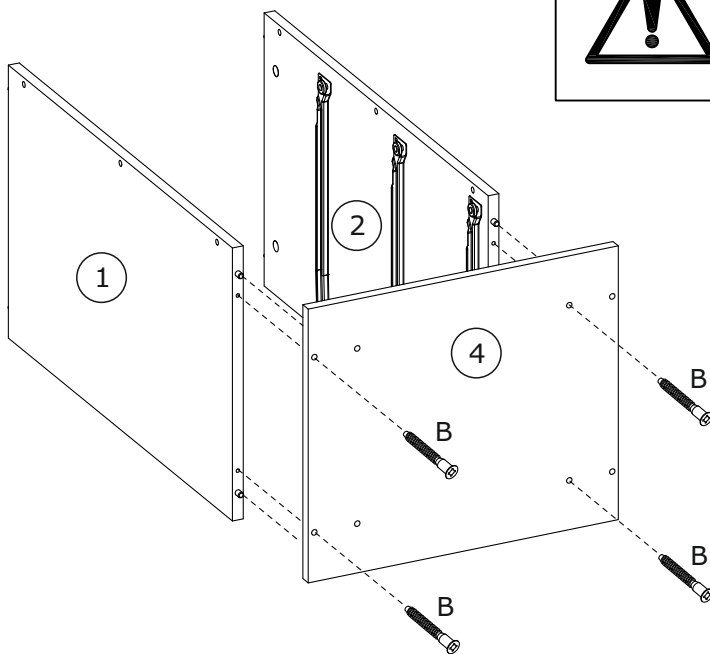
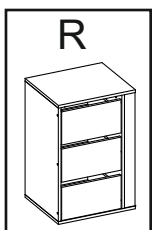

8

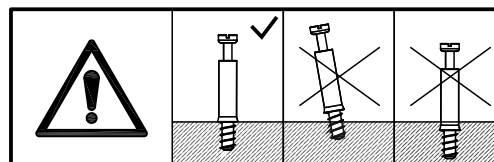
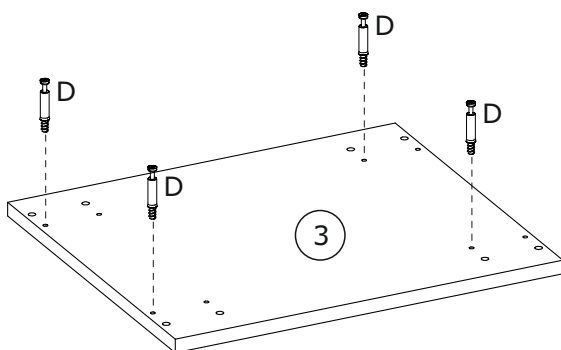
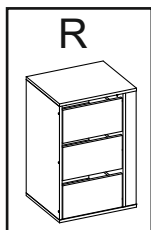

9

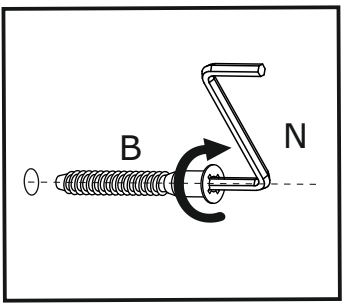
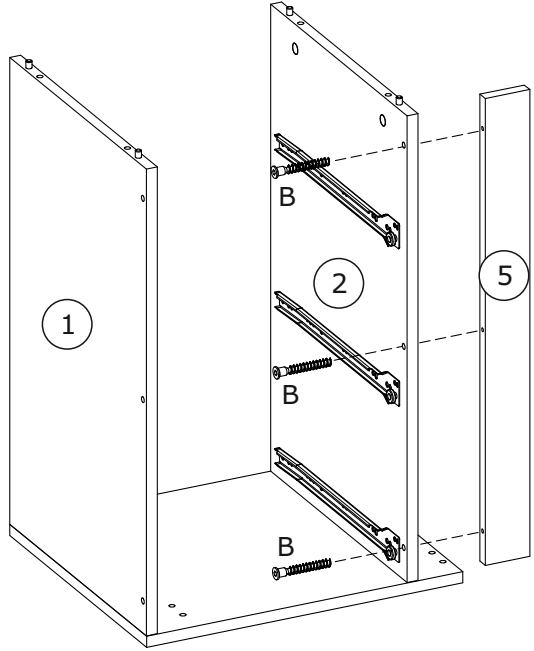
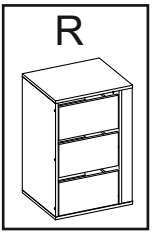
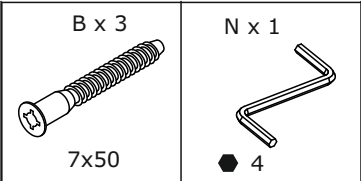

10

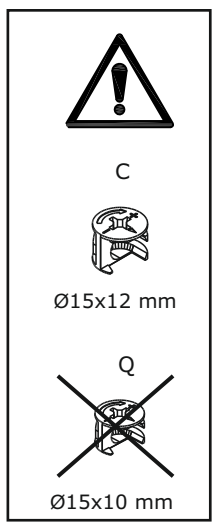
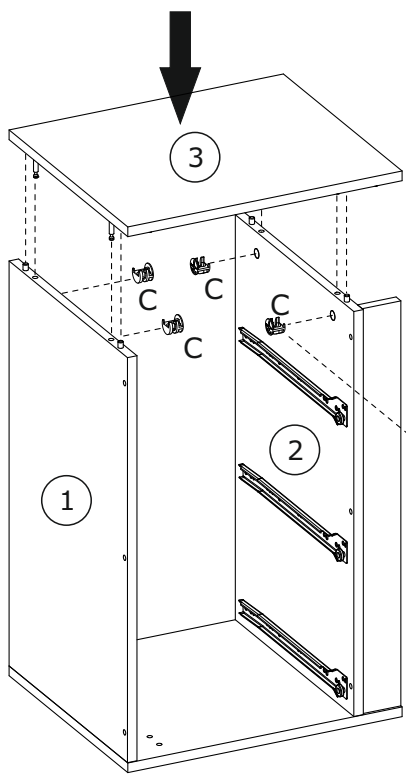
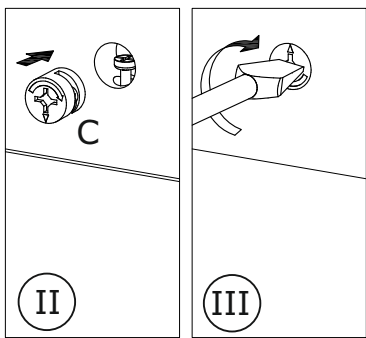
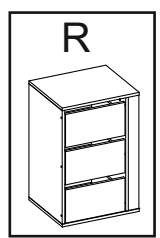
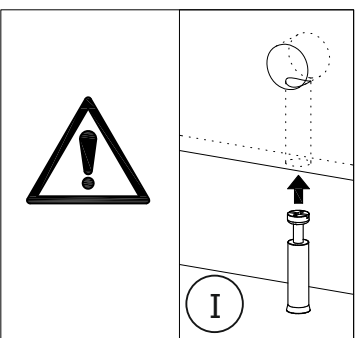
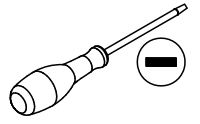

11

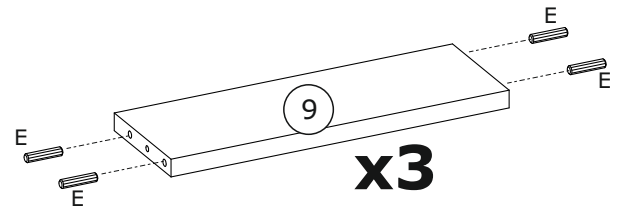
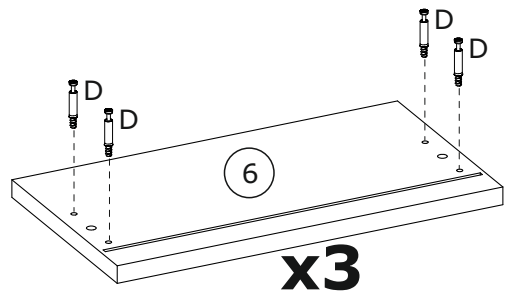
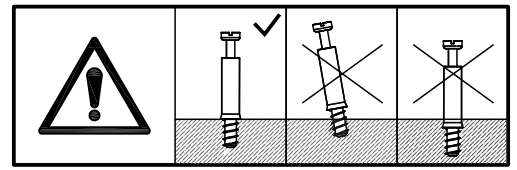
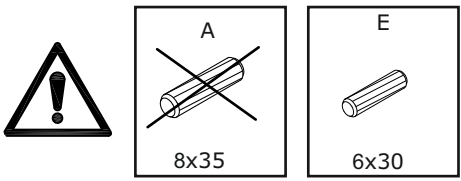
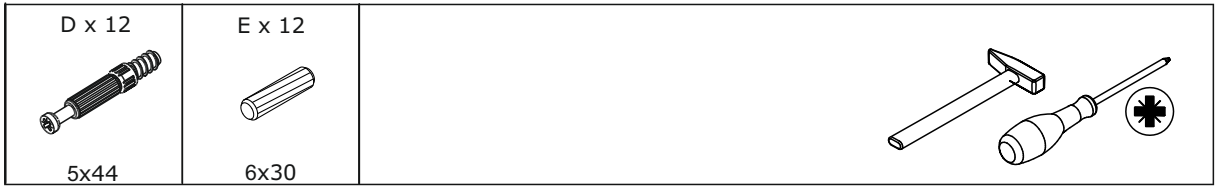

12

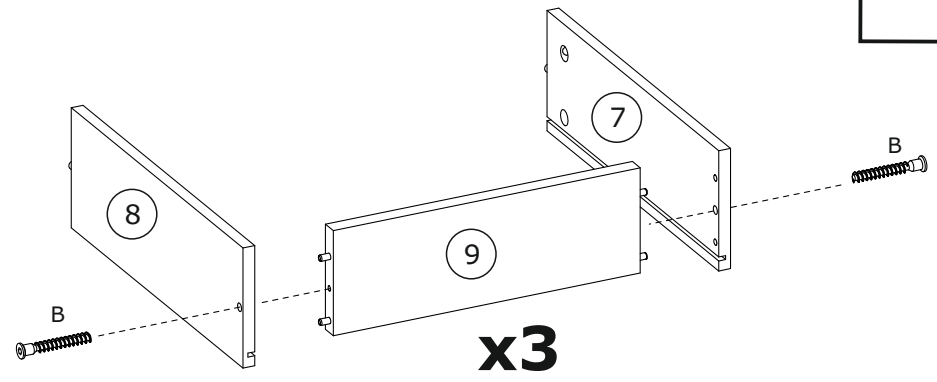
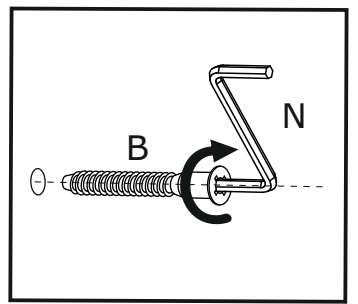
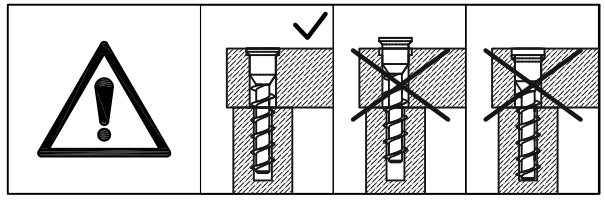
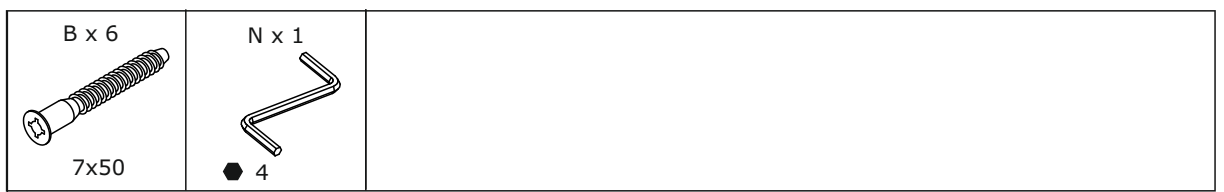

13

|   |   |   |
|---|---|---|
| Q x 12  | R x 12  |  |
|  |  |   |
| 15x10   | 20  |   |

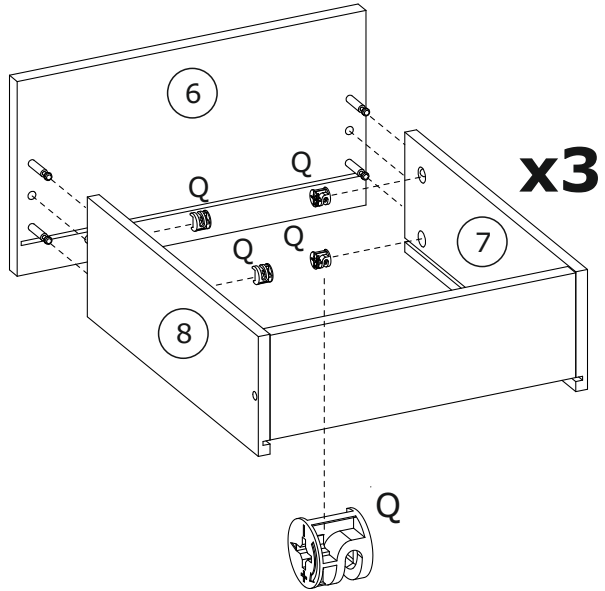
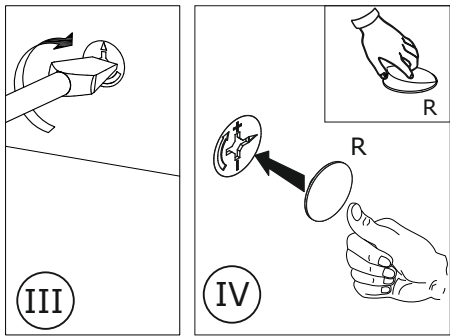
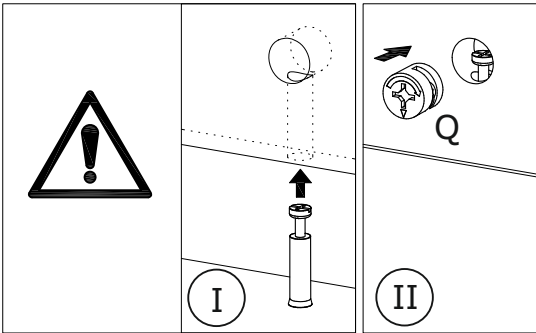

14

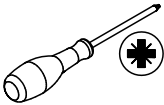
|   |  |   |
|---|--|---|
| I x 9   |  |  |
|  |  |   |
| 3x20  |  |   |

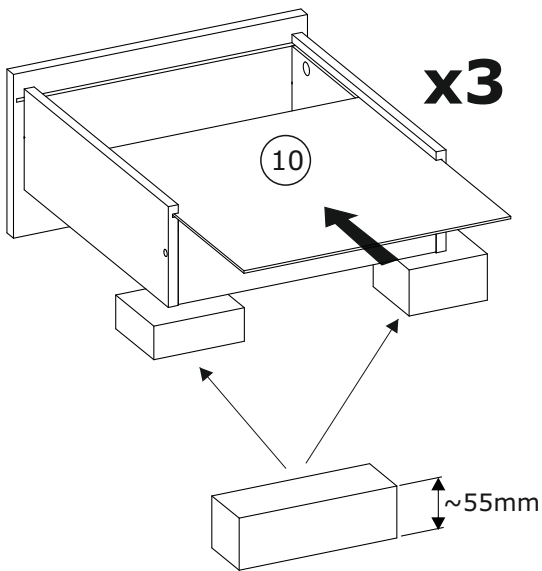

$xx = yy = 90^\circ$

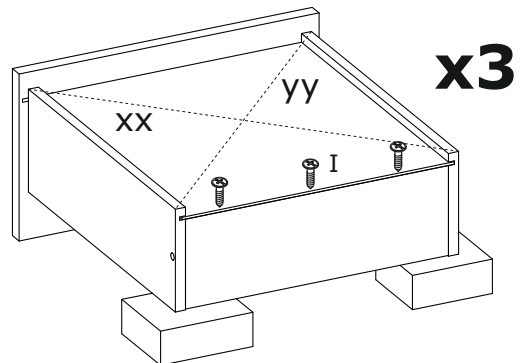
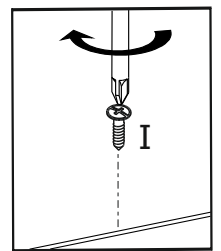

15

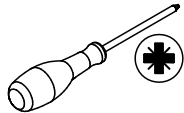
|   |   |   |
|---|---|---|
| I x 12<br><br>3x20 | U x 3<br><br>350 |  |
|---|---|---|

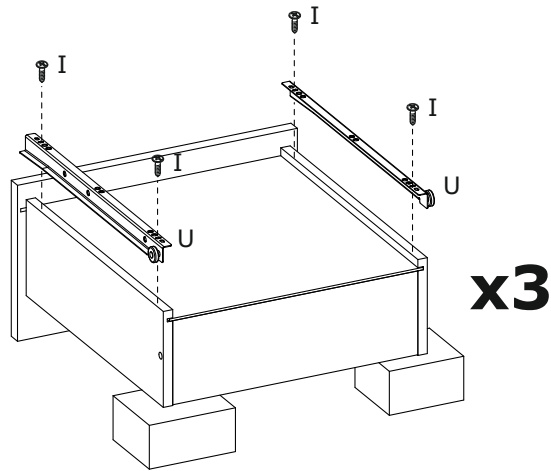
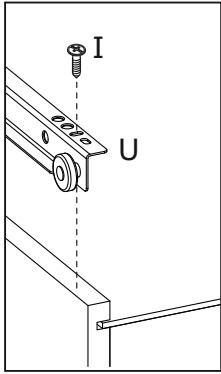

x3

16

