

Instructions and Precautions for Chair Use

Instructions for use

Sit steadily:

Be careful to sit steadily when using the chair, and do not shake or swing the chair to avoid accidental falls or unstable sitting posture.

Don't jump:

Don't jump up or down from the chair to prevent the chair from tipping over or spraining.

Don't climb:

Don't put your feet on the chair, don't lean on the back or armrests of the chair, so as not to cause the chair to be unstable, resulting in a fall.

Should not be too heavy:

The chair has a limited weight capacity, do not exceed 300 lbs to avoid damage or accidental injury.

Regular inspection:

Regularly check the sturdiness and stability of the chair, if found loose, wear and tear or other damage, should be promptly repaired or replaced.

Precautions

⚠ Pay attention to the environmental humidity:

The chair is more sensitive to the environmental humidity, should be placed in the temperature and humidity of the environment to avoid changes in humidity caused by deformation of the wood or color changes.

⚠ Avoid contact with sharp objects:

Avoid contact with sharp objects, hydrochloric acid, salt and other substances to prevent damage, deformation and corrosion.

⚠ Cleaning and maintenance:

Regular cleaning of the chair, you can use a damp cloth to wipe debris and stains, avoid the use of too stimulating detergents and chemicals or sharp objects to avoid damage to the chair.

USER MANUAL

Bar Stools

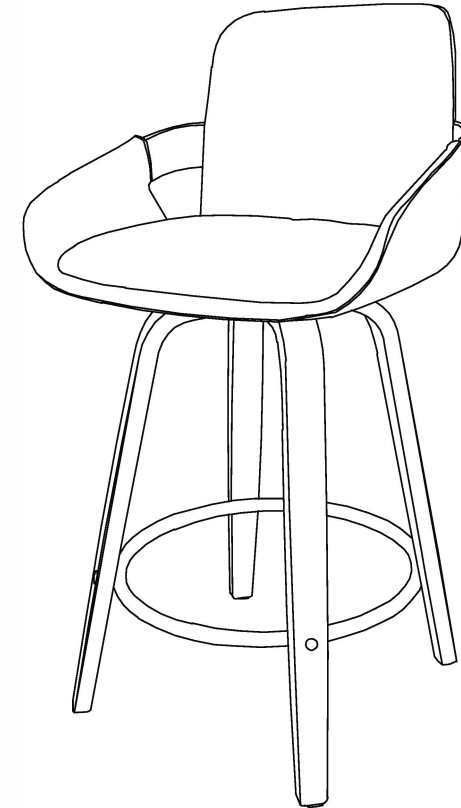

- All of our chairs are test fitted to ensure the quality of the chair before leaving the factory, so there may be signs of use, please rest assured that this is not a used chair.
- Please make sure the screws are tightened when installing the chair, which can ensure the firmness of the chair and no noise.

List of accessories

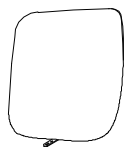

A1 x1

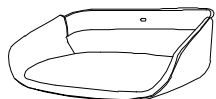

A2 x1



B x4

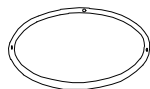

C x1

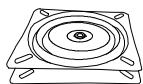

D x1



M6*20

E x14



M6*30

F x5



G x4



H x1



I x4



J x1

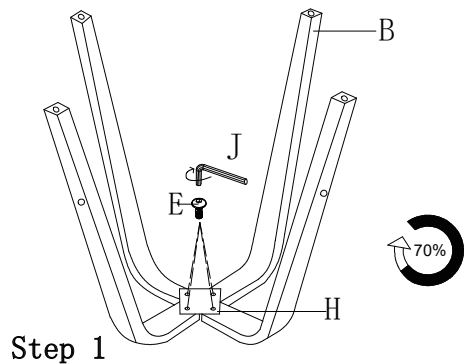

Step 1

Tip:
If the screw hole on the last leg cannot align with the hole, loosen the screws on the front three legs to adjust the distance.

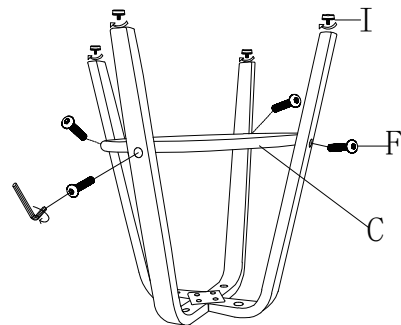

Step 2

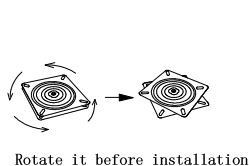

Step 3

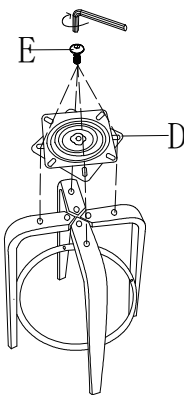

Tip:
Align the holes, tighten the screws to 70%, ensure smooth connection, and then tighten to 100%

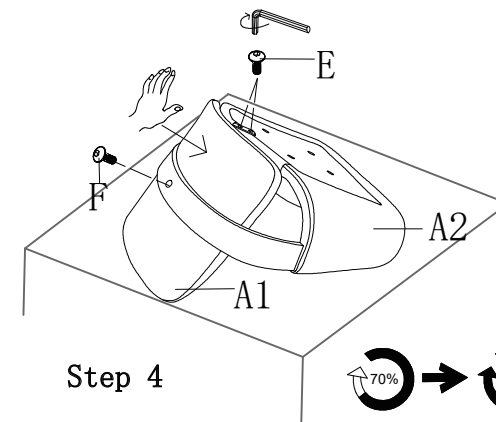

Step 4

Tip:
1. Place the chair upside down on a flat surface, align the holes, and tighten the E screw to 70%.
2. When operating the F screw, you can press it down by hand and tighten the screw to 70%.
3. After the hole position is smooth, tighten all screws to 100%

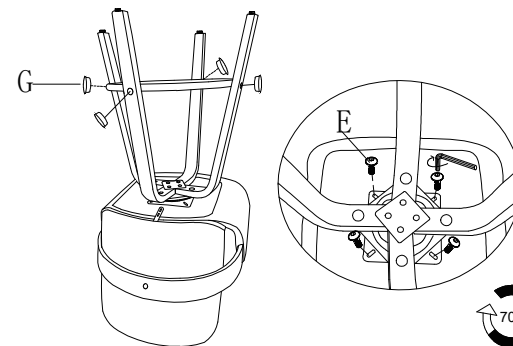

Step 5

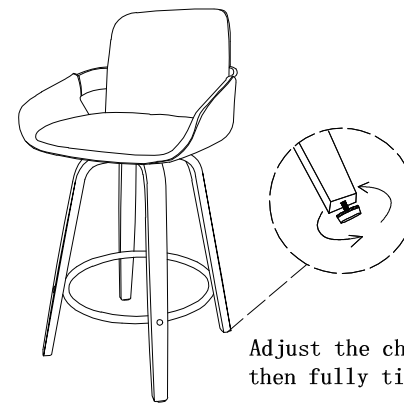

Step 6

Adjust the chair so that it is leveled, then fully tighten all the screws