

INSTALLATION

Product Manual

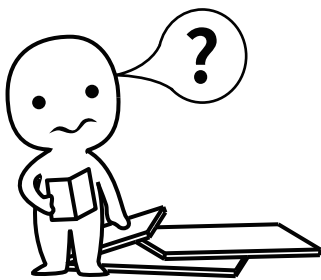

IMPORTANT INFORMATION!

please read the entire manual before starting to assemble and/or using this product. follow the manual thoroughly and keep it for further reference.

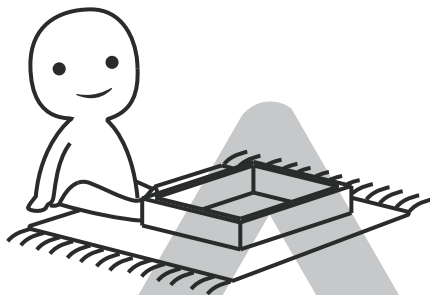

AVOID SCRATCHES!

In order to avoid scratching this furniture should be assembled on a soft layer- could be a rug.

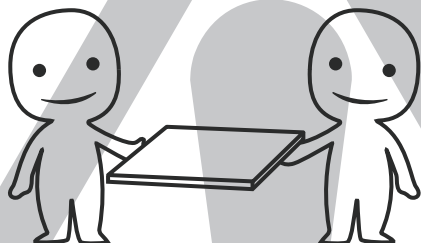

IMPROVE EFFICIENCY !

Try to find a partner to install with you, which can speed up the installation efficiency and shorten the time.

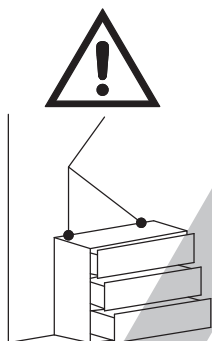

ANTI-TOPPLE WARNING !

Overturnd furniture can cause serious or fatal crush injuries. To prevent tipping over, be sure to use the wall attachment, if not included with this product. Please purchase the wall attachment that fit your wall. If unsure, seek professional advice. Please read and follow each step of the instructions carefully.

IMPORTANT !

It is important that any product which is assembled using any kind of screw is re-tightened 2 weeks after assembly, and once every 3 months - in order to assure stability through-out the lifespan of the product.

For regular maintenance and cleaning of the product, for the frame, please use a rag dipped in neutral detergent to fully wipe it, and then dry it with a clean rag. For glass materials, wipe with a rag dampened with water glass cleaner, and then dry with a dry rag.

Do not use an electric screwdriver, and do not use too much force when installing, because the board is easy to break.

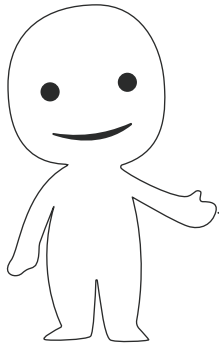

Please prepare the following tools

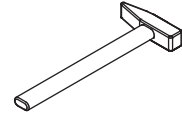
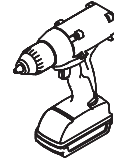
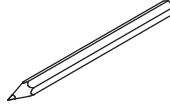
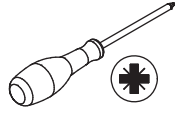

When installing, please carefully confirm whether each screw corresponds to the manual, accessories with similar shapes can be distinguished by size

A x 12



CRE0420A

B x 70



∅ 2 x 16 mm

C x 4



D x 21



CRC0540A

E x 66



CRB1595A

F x 72



CRD0416A

G x 66

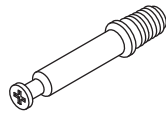

CRA0635A

H x 6

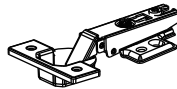

DGA861A

I x 6



DGA861B

J x 4

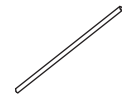

400 mm

K x 1

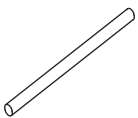

374 mm

L x 18

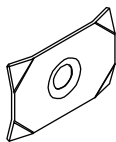

M x 1

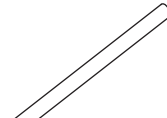

768 mm

N x 2



200 mm

O x 2

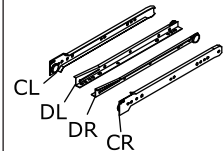

WX0816A

P x 2



Q x 24



CRD3514A

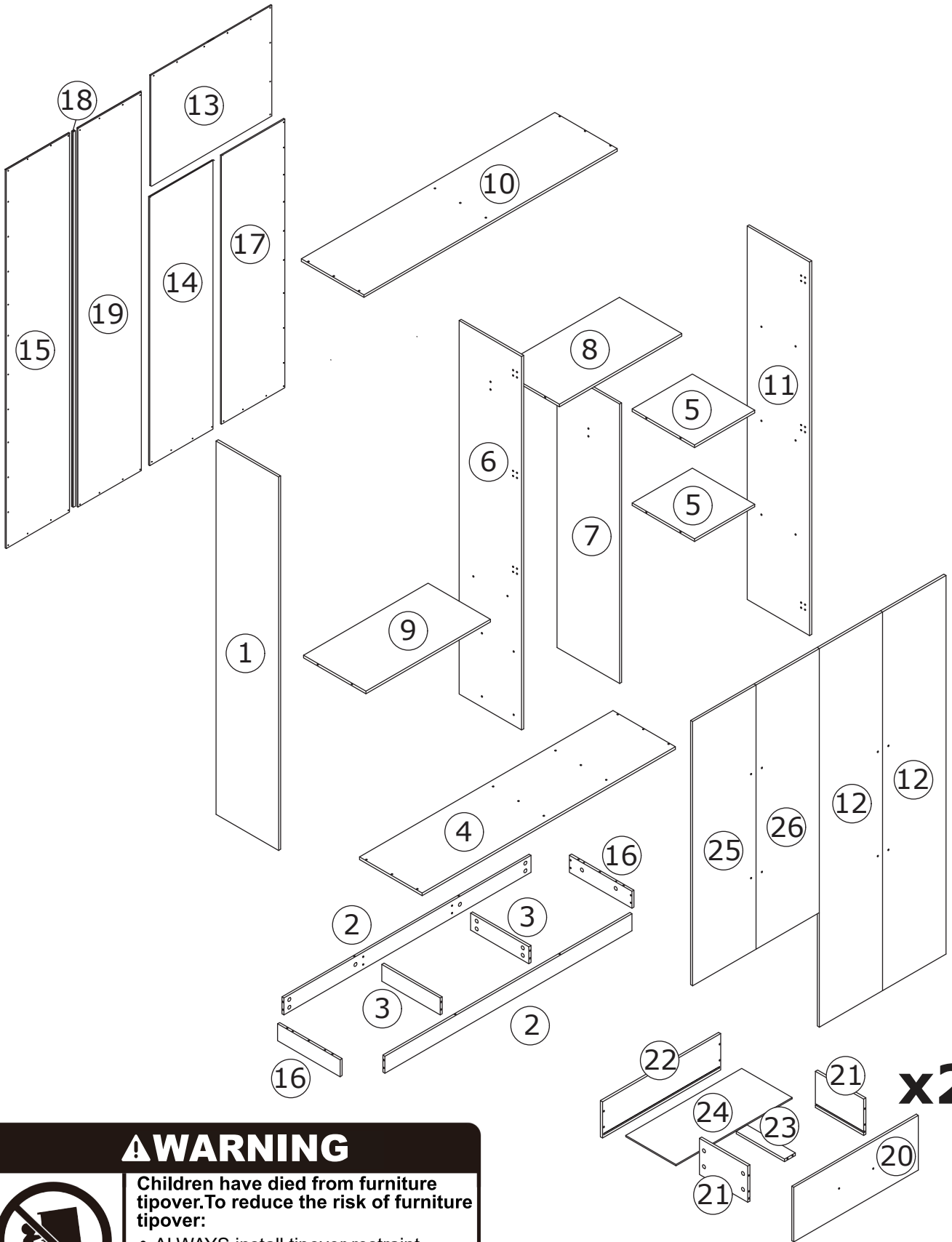

⚠ WARNING

Children have died from furniture tipover. To reduce the risk of furniture tipover:

- ALWAYS install tipover restraint provided.
- NEVER put a TV on this product.
- NEVER allow children to stand, climb or hang on drawers, doors, or shelves.
- NEVER open more than one drawer at a time.
- Place heaviest items in the lowest drawers.

This is a permanent label. Do not remove!

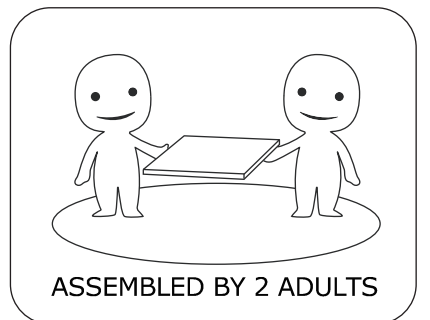
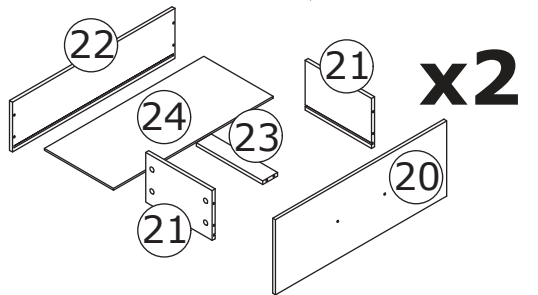

1

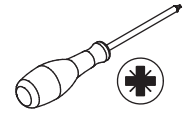
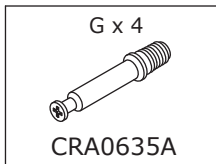

Insert eccentric rod(G) into board 7 with a screwdriver as shown.

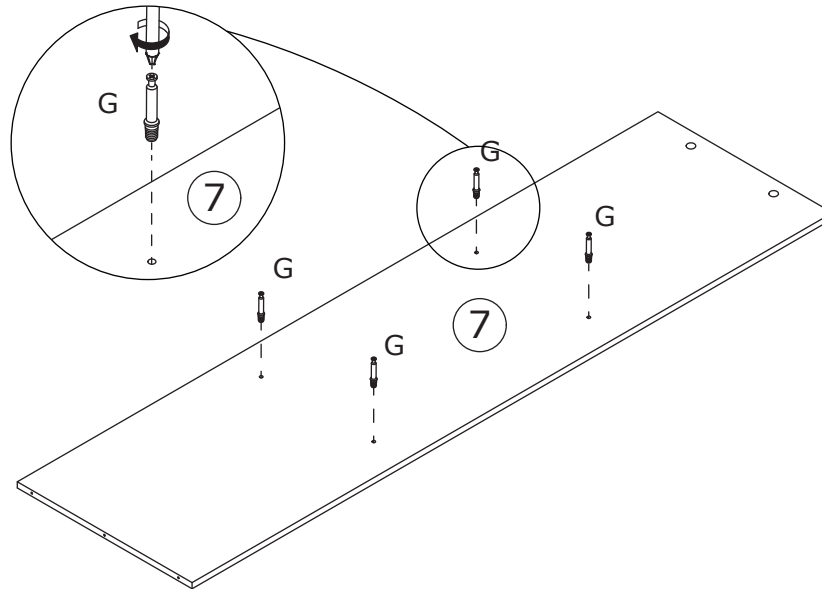
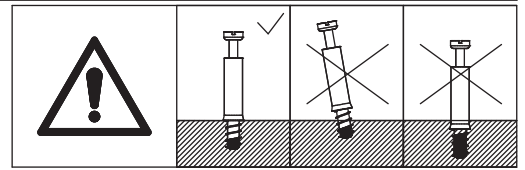

2

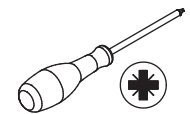
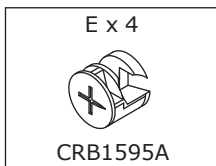

Attach two board 5 to board 7, put cam lock(E) into holes in board 5 and turn clockwise to tighten as shown.

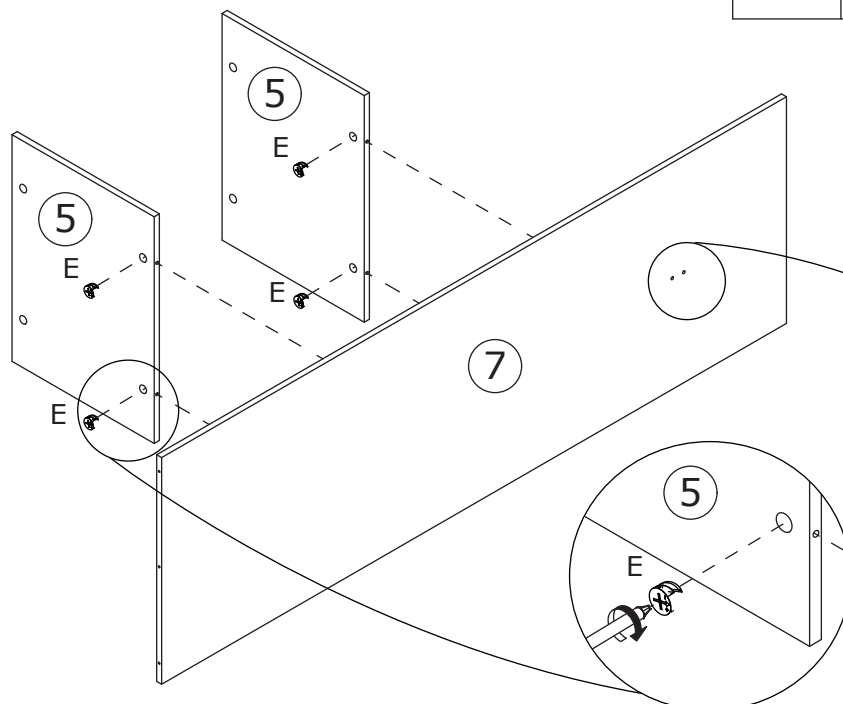
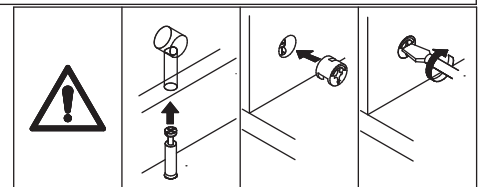

The holes are facing up



3

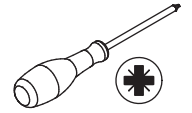
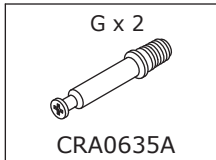

Insert eccentric rod(G) into board 8 with a screwdriver as shown.

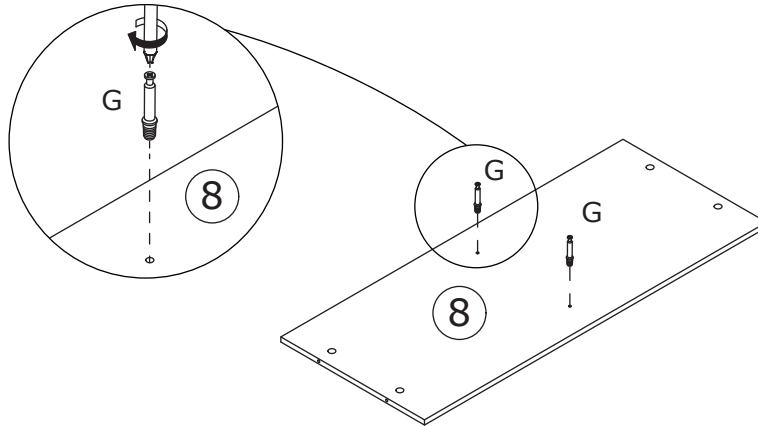
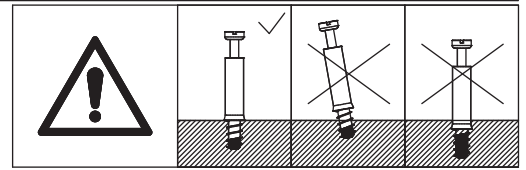

4

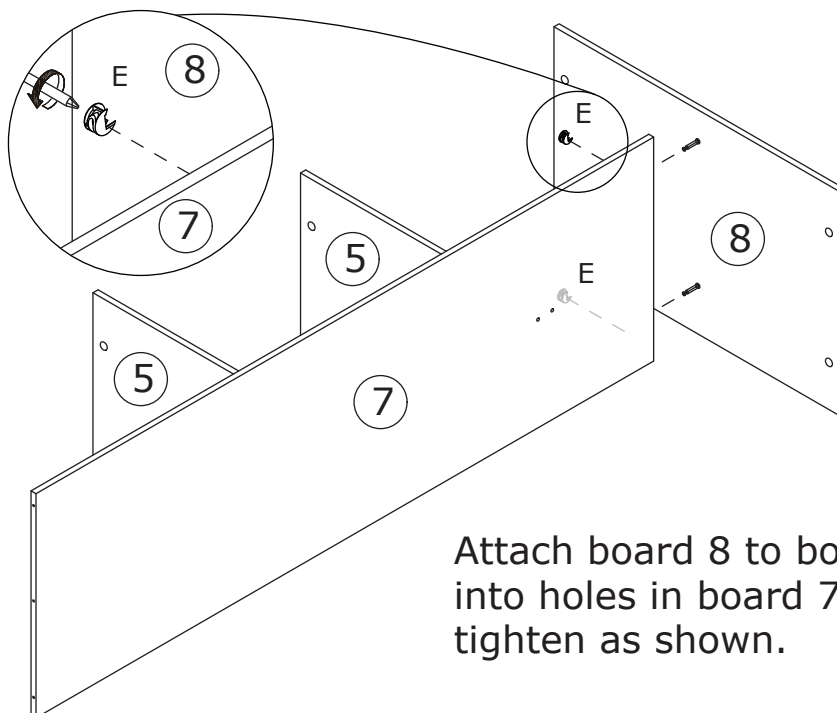
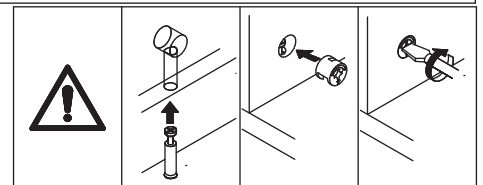
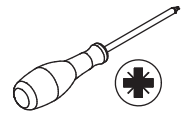
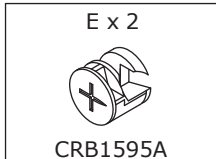

Attach board 8 to board 7, put cam lock(E) into holes in board 7 and turn clockwise to tighten as shown.

5



Fix slide rail(CR) to board 6 using screw(Q) as shown.

CR

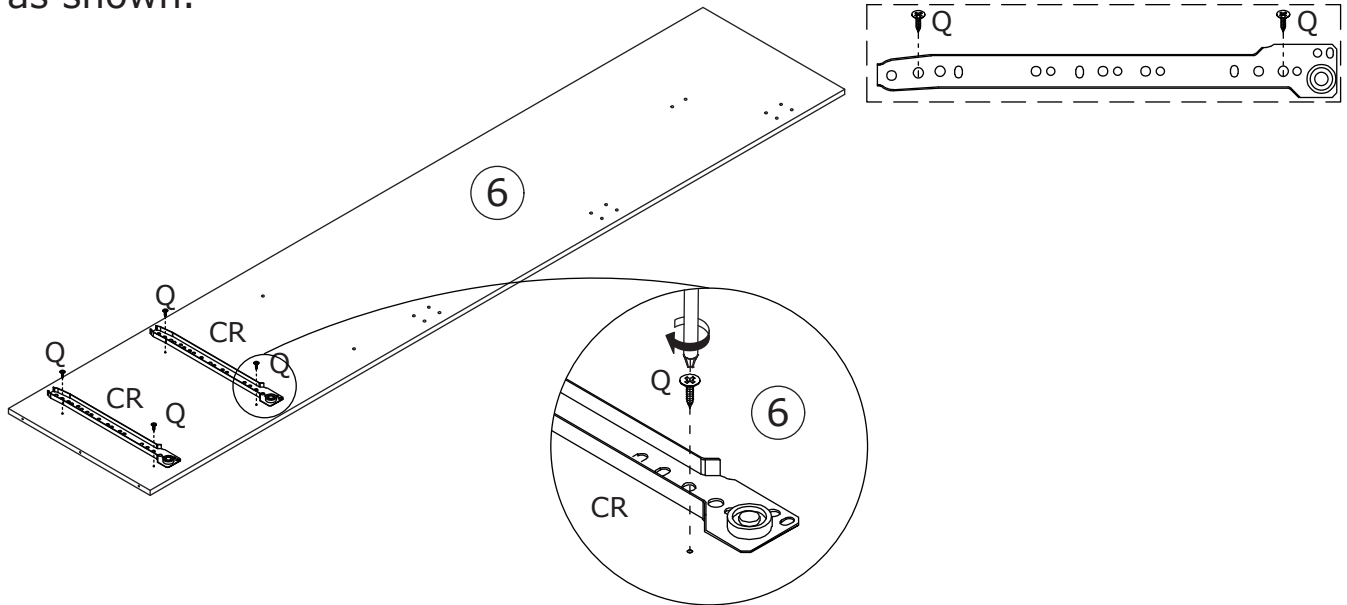

6

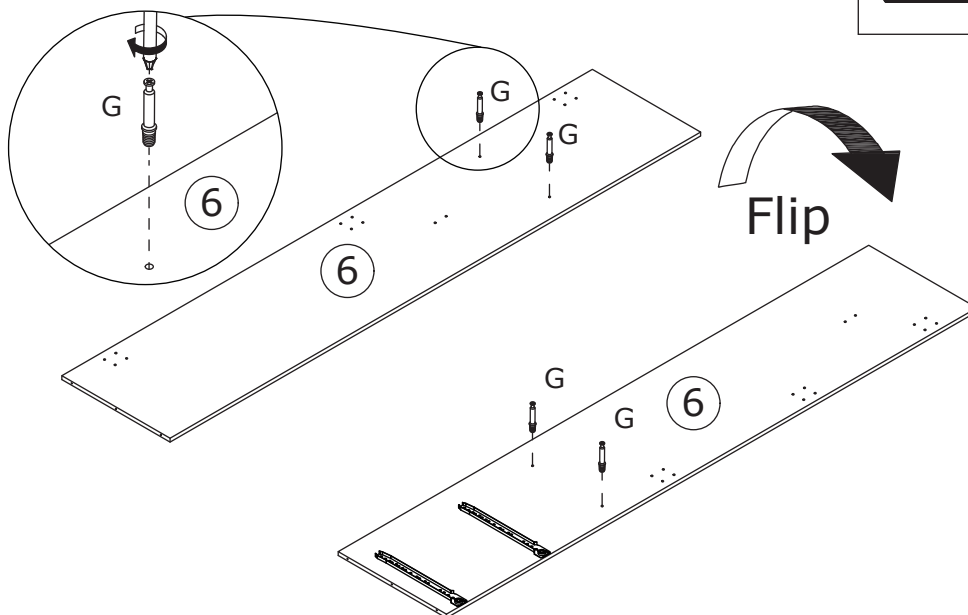
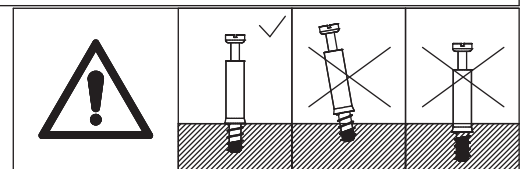

Insert eccentric rod(G) into corresponding holes in board 6 at first. Flip the plate, insert quickfit screw(G) as shown.

7

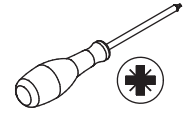
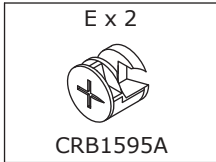

Attach board 6 to board 8, put cam lock(E) into holes in board 8 and turn clockwise to tighten as shown.

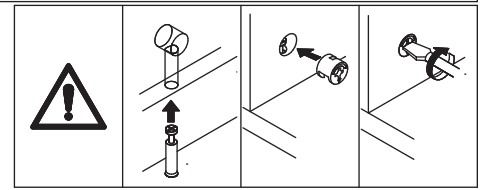

The holes are facing down

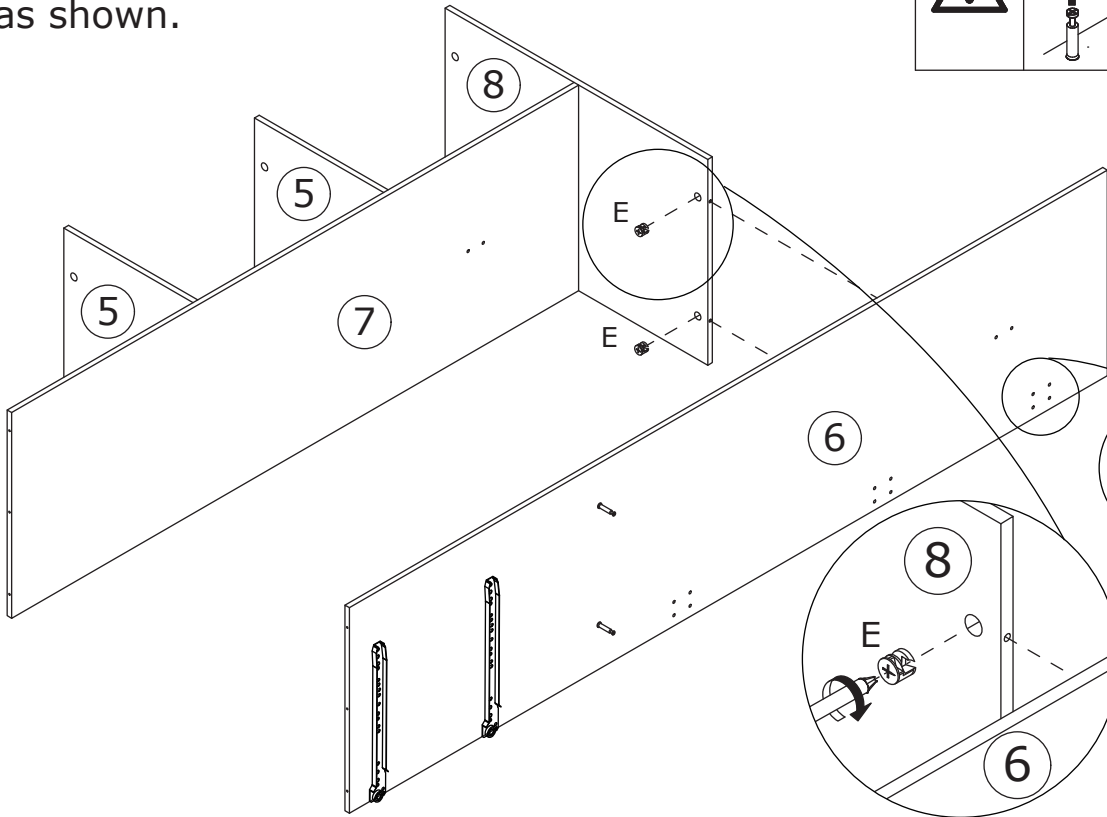

8

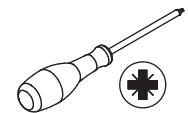
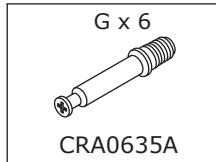

Insert eccentric rod(G) into corresponding holes in board 11 as shown.

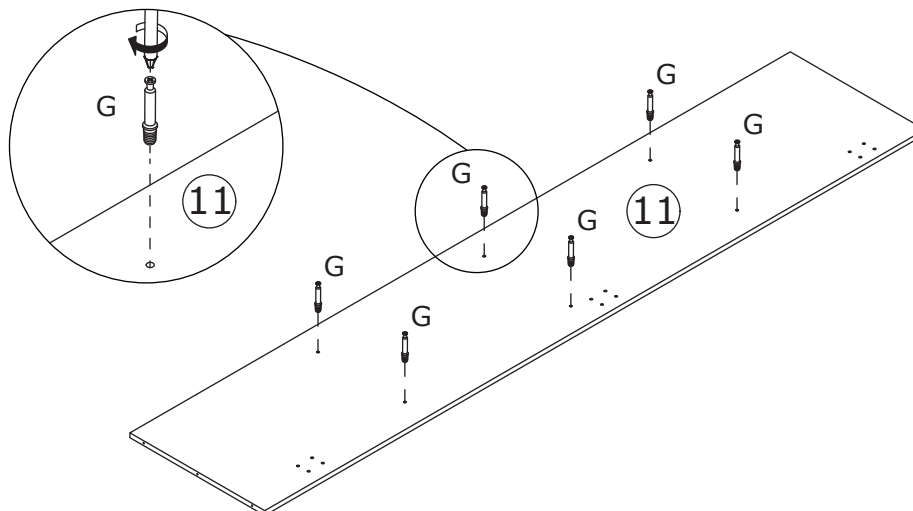
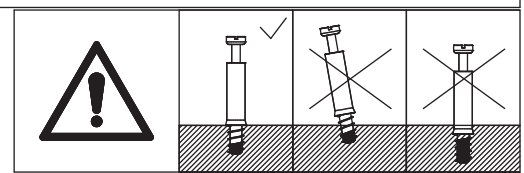

9

E x 6
CRB1595A

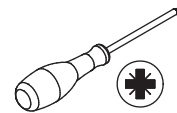

Attach board 11 to board 5 and 8, put cam lock(E) into holes in board 5,8 and turn clockwise to tighten as shown.

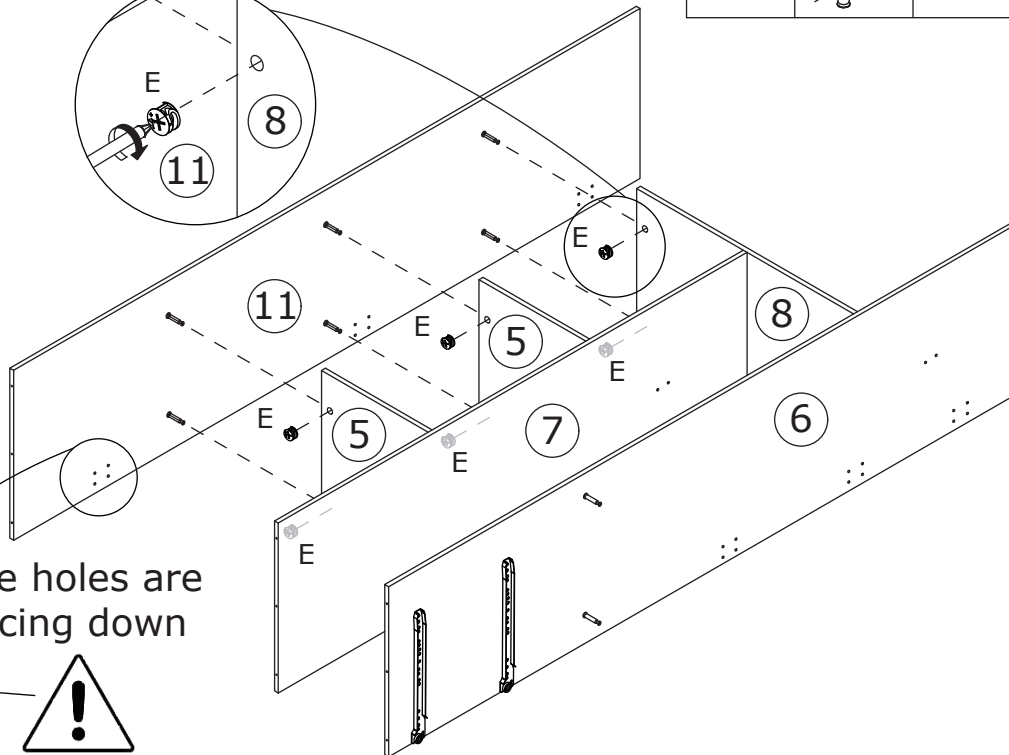
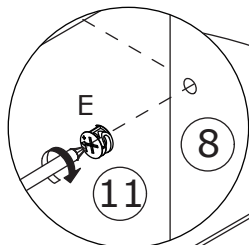
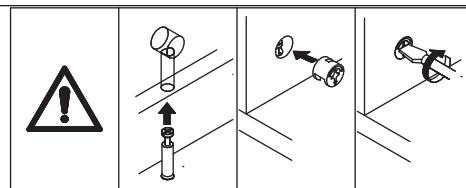

The holes are facing down



10

E x 2
CRB1595A

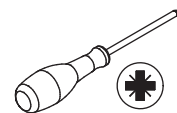

Attach board 9 to board 6, put cam lock(E) into holes in board 9 and turn clockwise to tighten as shown.

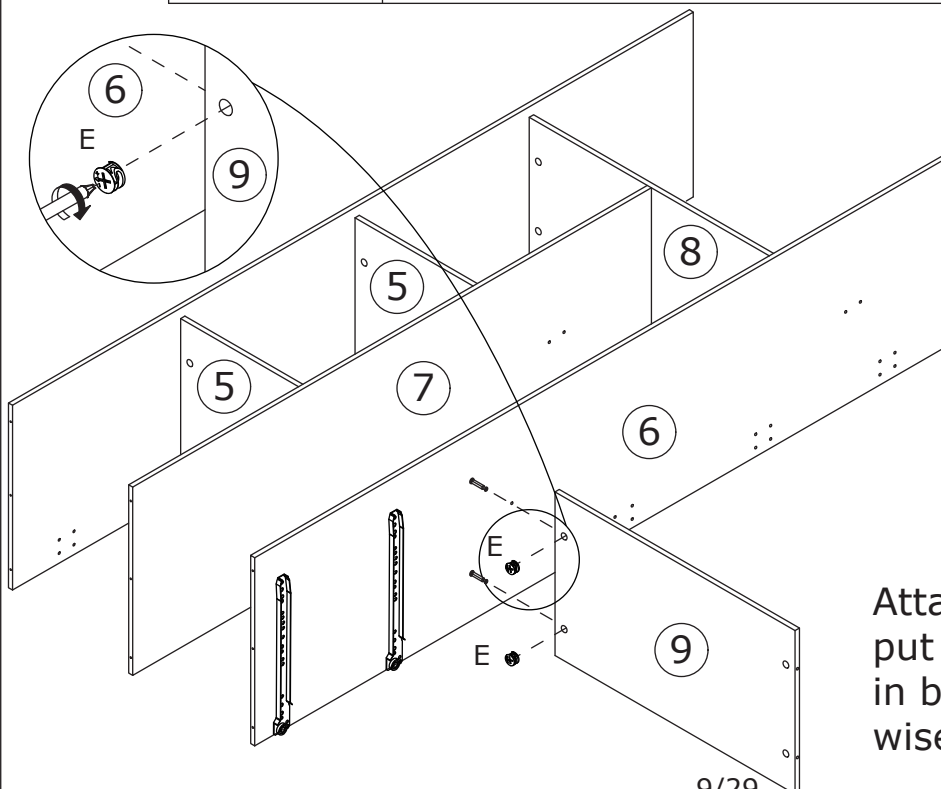
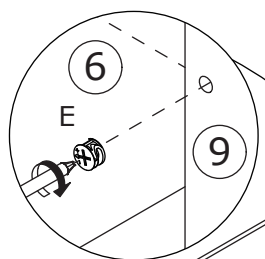
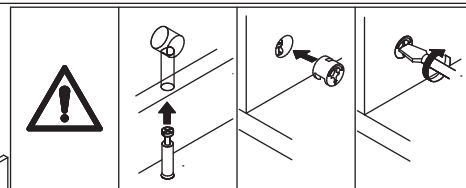

11

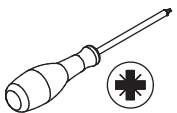
Q x 4  CRD3514A	O x 2  CL WX0816A	
--	---	---

Fix slide rail(CL) to board 1 using screw(Q) as shown.

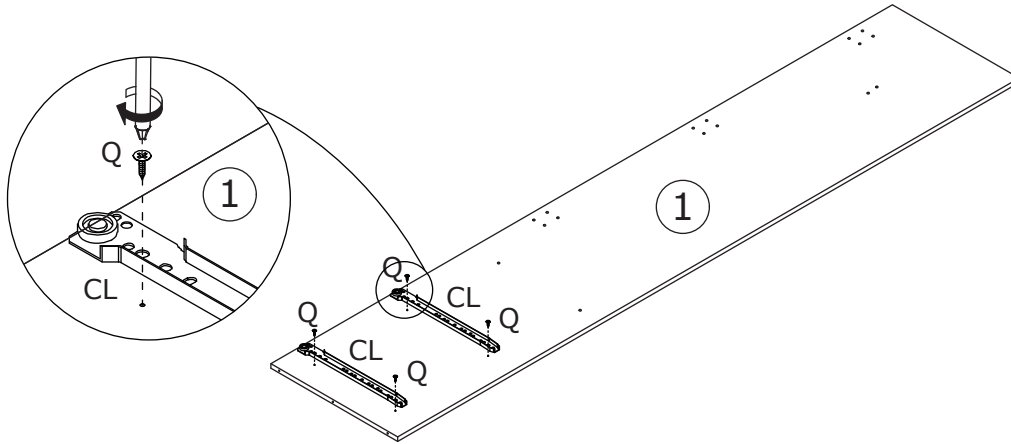
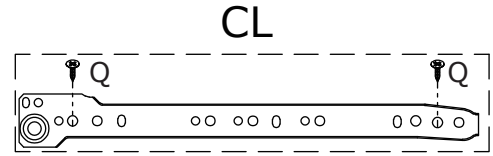

12

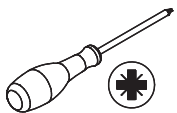
G x 2  CRA0635A	
--	---

Insert eccentric rod(G) into board 1 as shown.

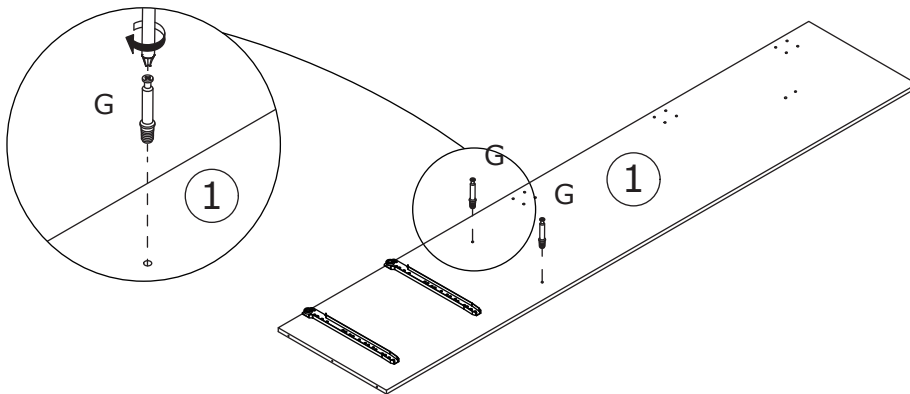
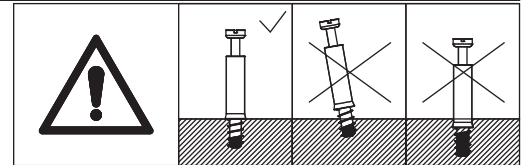

13

E x 2



CRB1595A

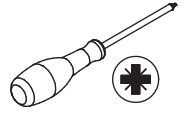

Attach board 1 to board 9, put cam lock(E) into holes in board 9 and turn clockwise to tighten as shown.

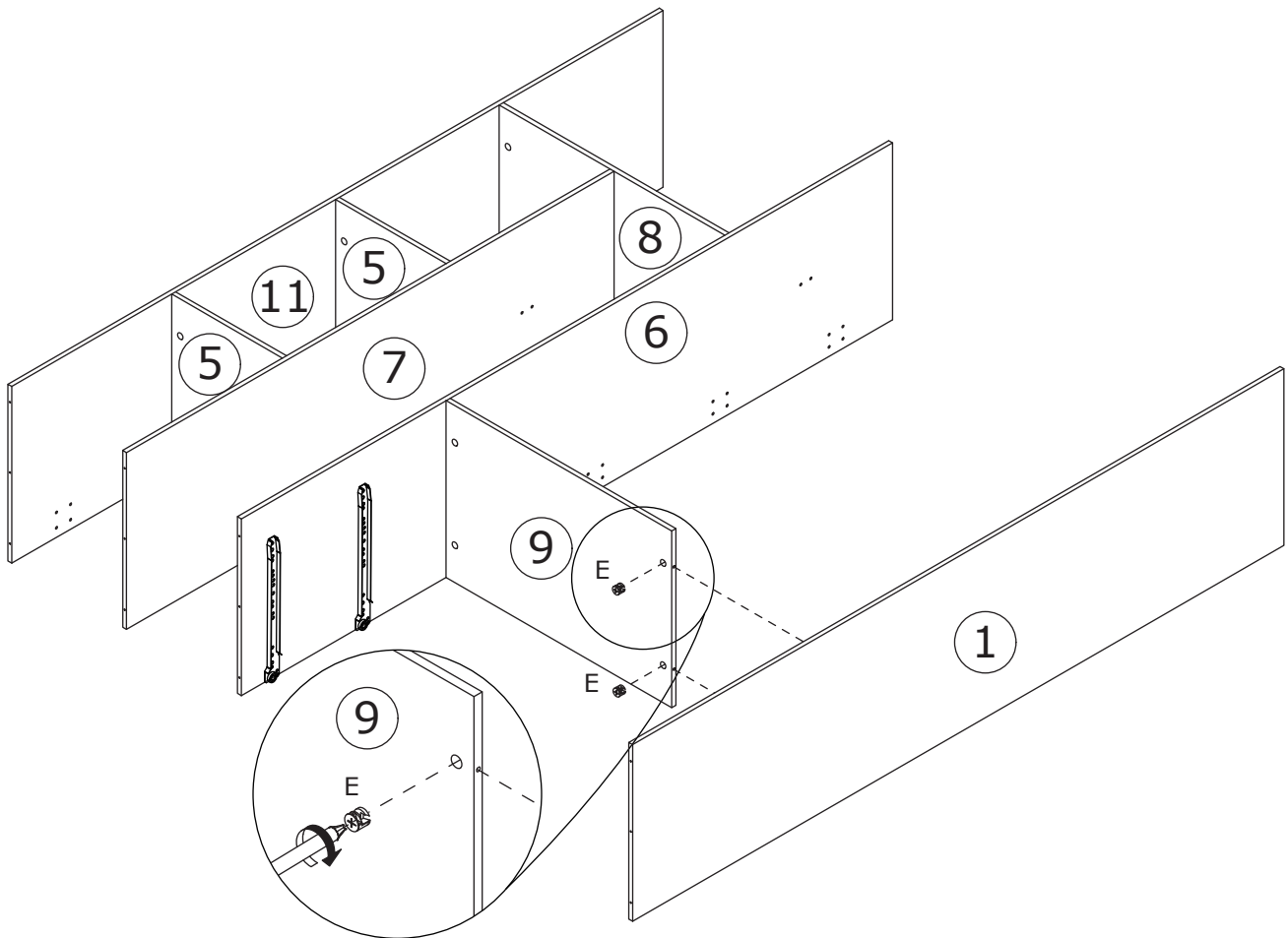
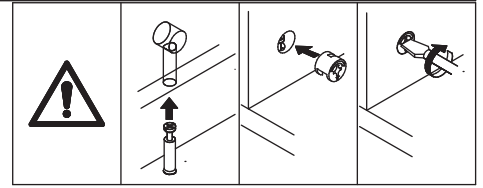

14

D x 9
CRC0540A

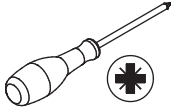

Cover board 10 to board 11, 6 and 1, then fix using screw(D) as shown.

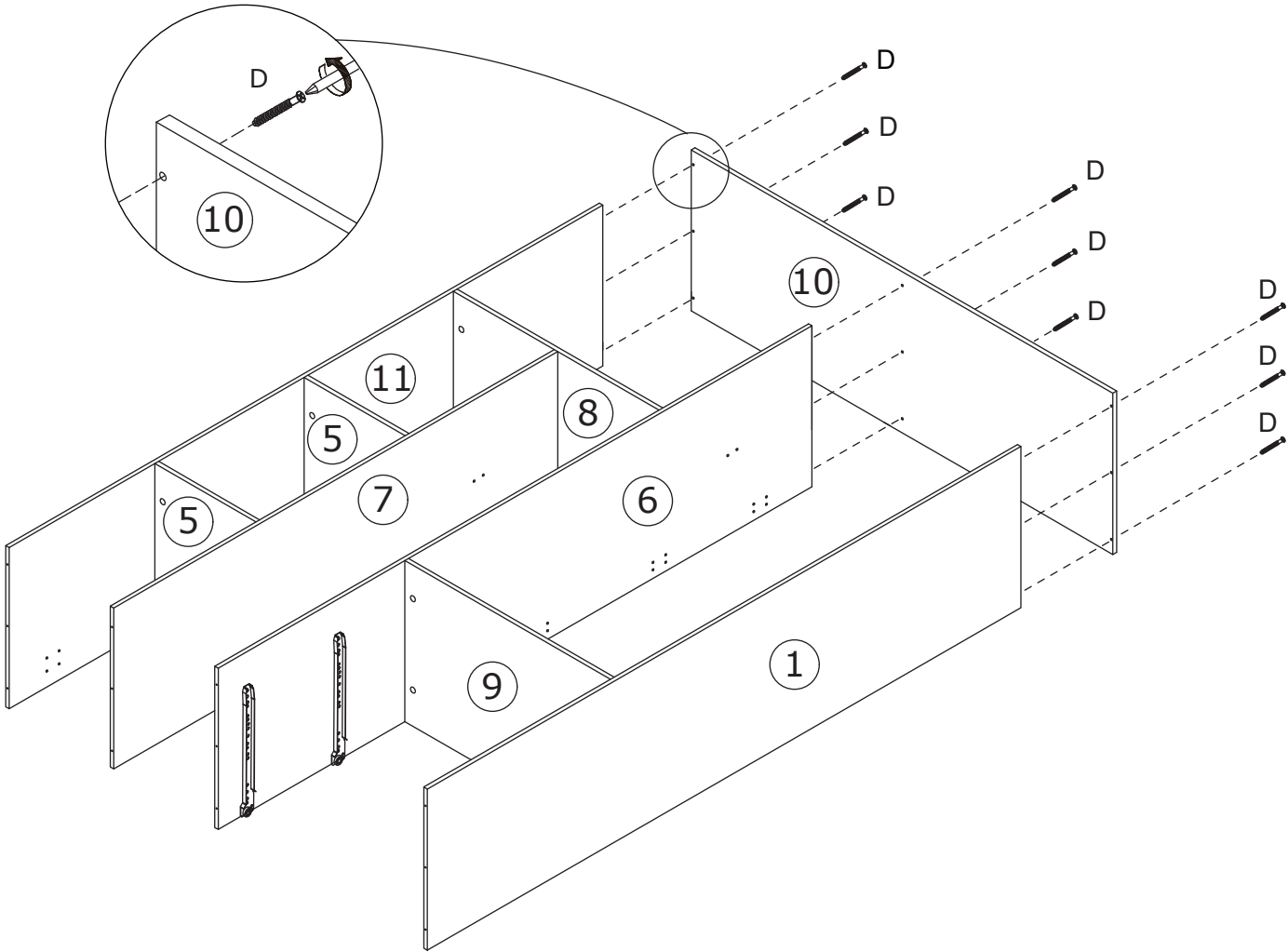

15

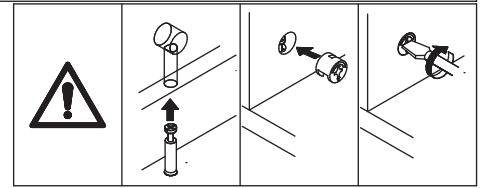
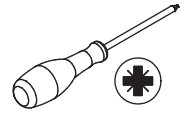
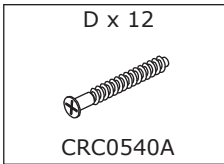

Then fix plate 4 to plate 11,7,6 and 1 using screw(D) as shown.
Please pay attention where the holes are inserted.

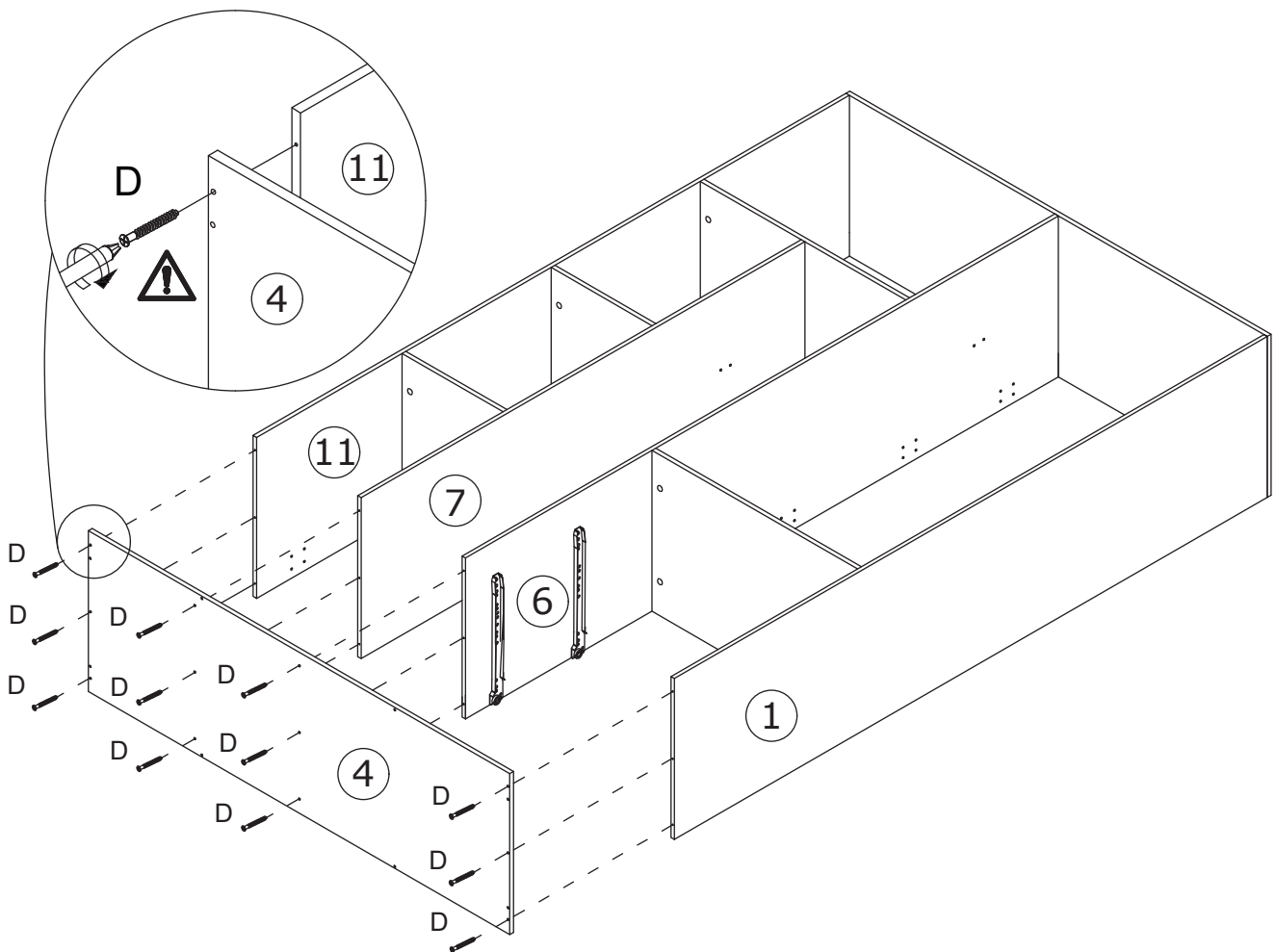

16

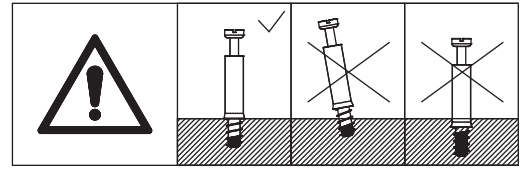
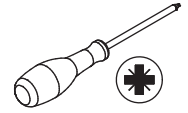
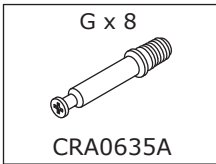

Insert eccentric rod(G) into corresponding holes in board 4 as shown.
Please pay attention where the holes are inserted.

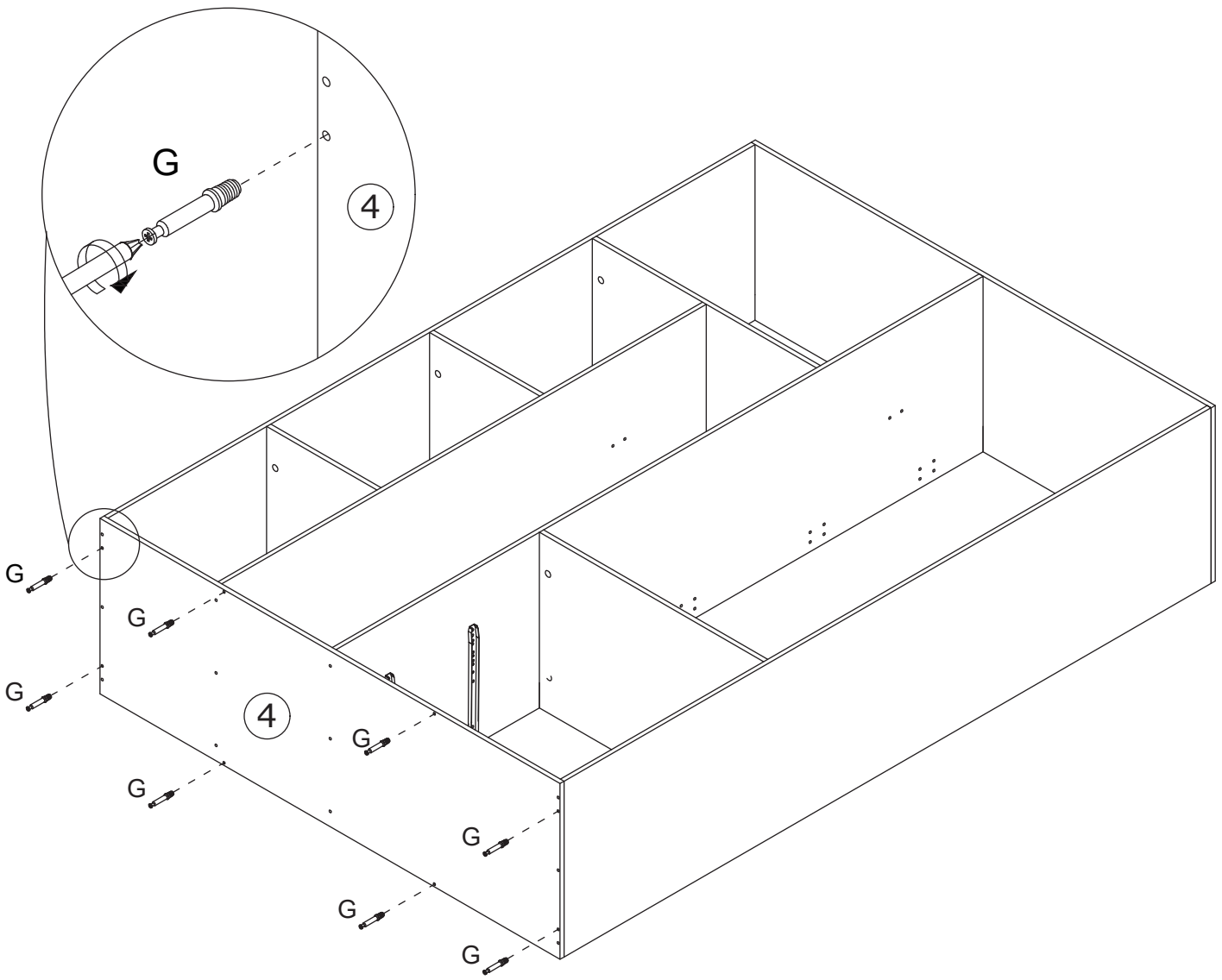

17

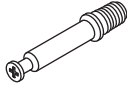
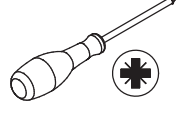
G x 8  CRA0635A	
--	---

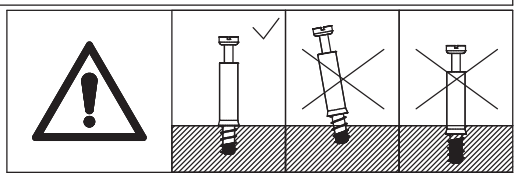
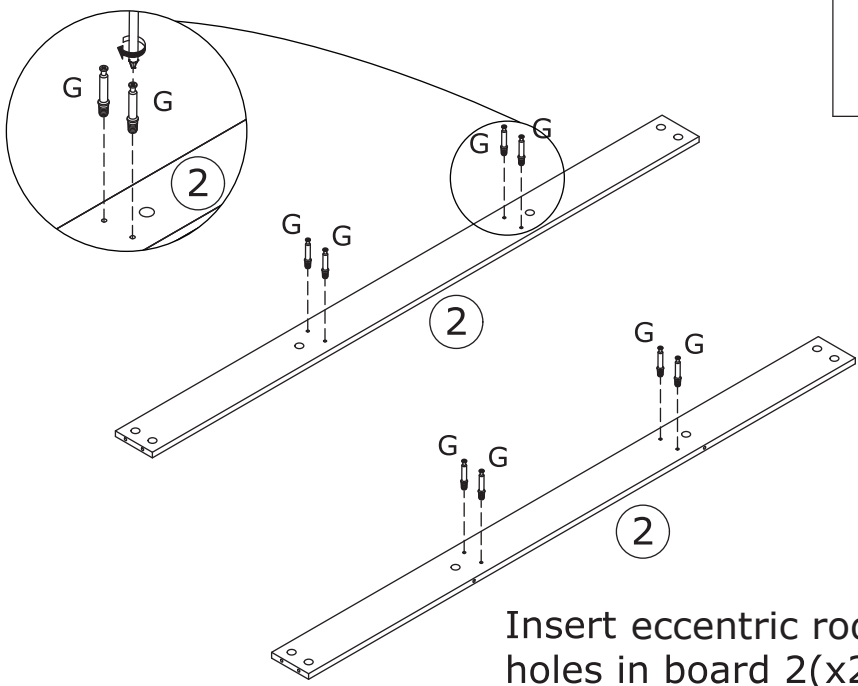

Insert eccentric rod (G) into corresponding holes in board 2(x2) as shown.

18

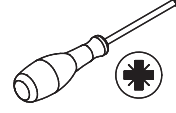
E x 8  CRB1595A	
--	---

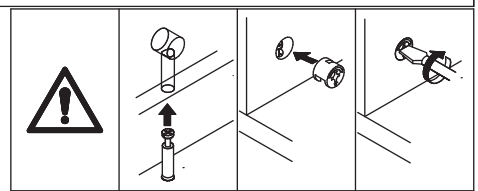
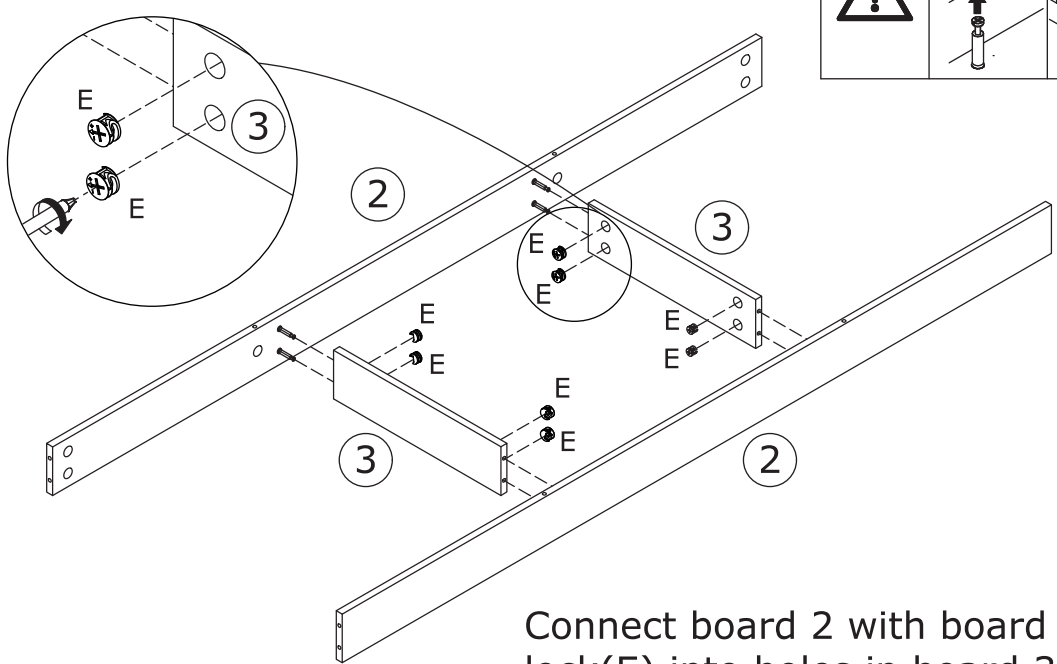

Connect board 2 with board 3, put cam lock(E) into holes in board 3 and turn clockwise to tighten as shown.

19

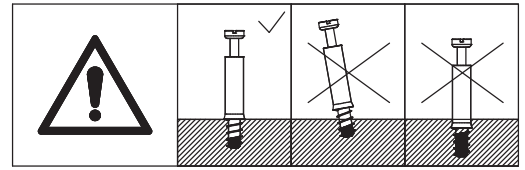
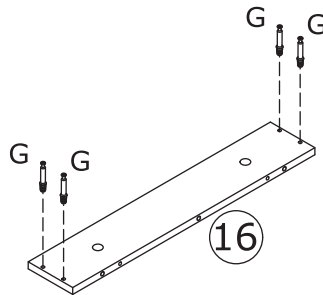
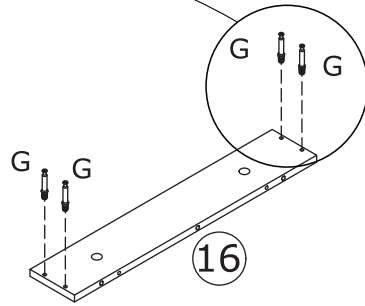
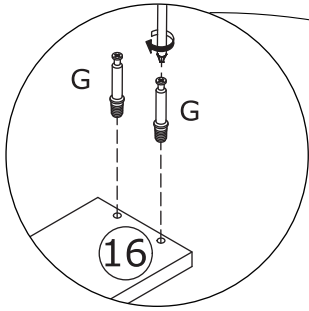
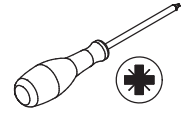
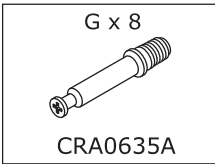

Insert eccentric rod (G) into board 16(x2) as shown.

20

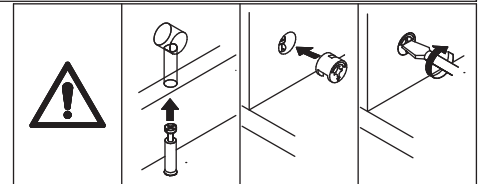
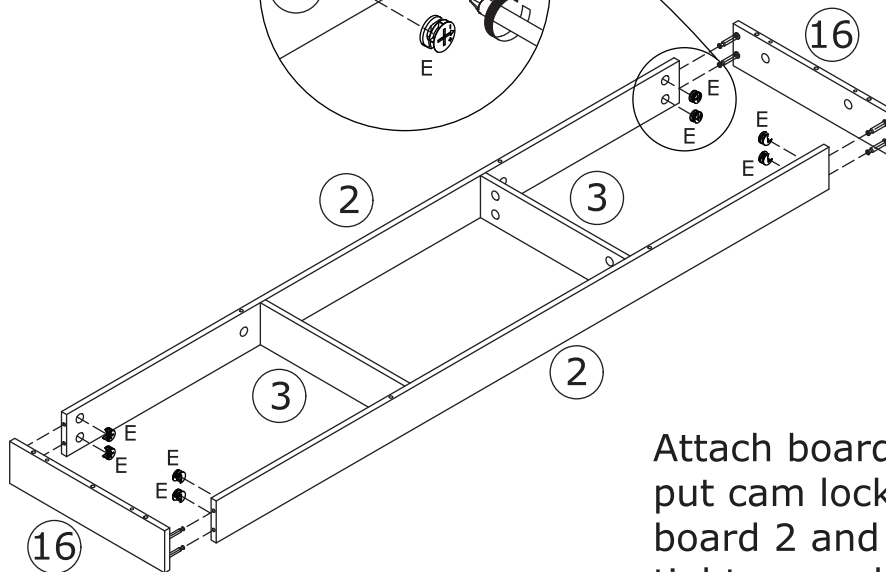
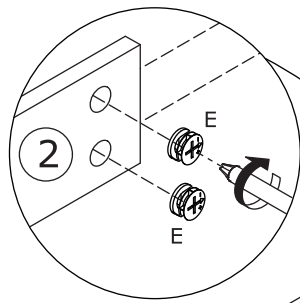
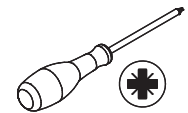
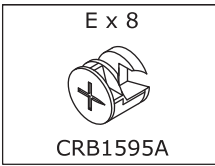

Attach board 16 to board 2, put cam lock(E) into holes in board 2 and turn clockwise to tighten as shown.

21

E x 8
CRB1595A

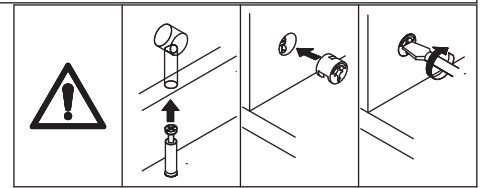
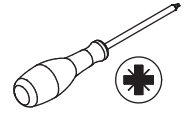

Attach the frame to board 4, put cam lock(E) into holes in board 2,16 and turn clockwise to tighten as shown.

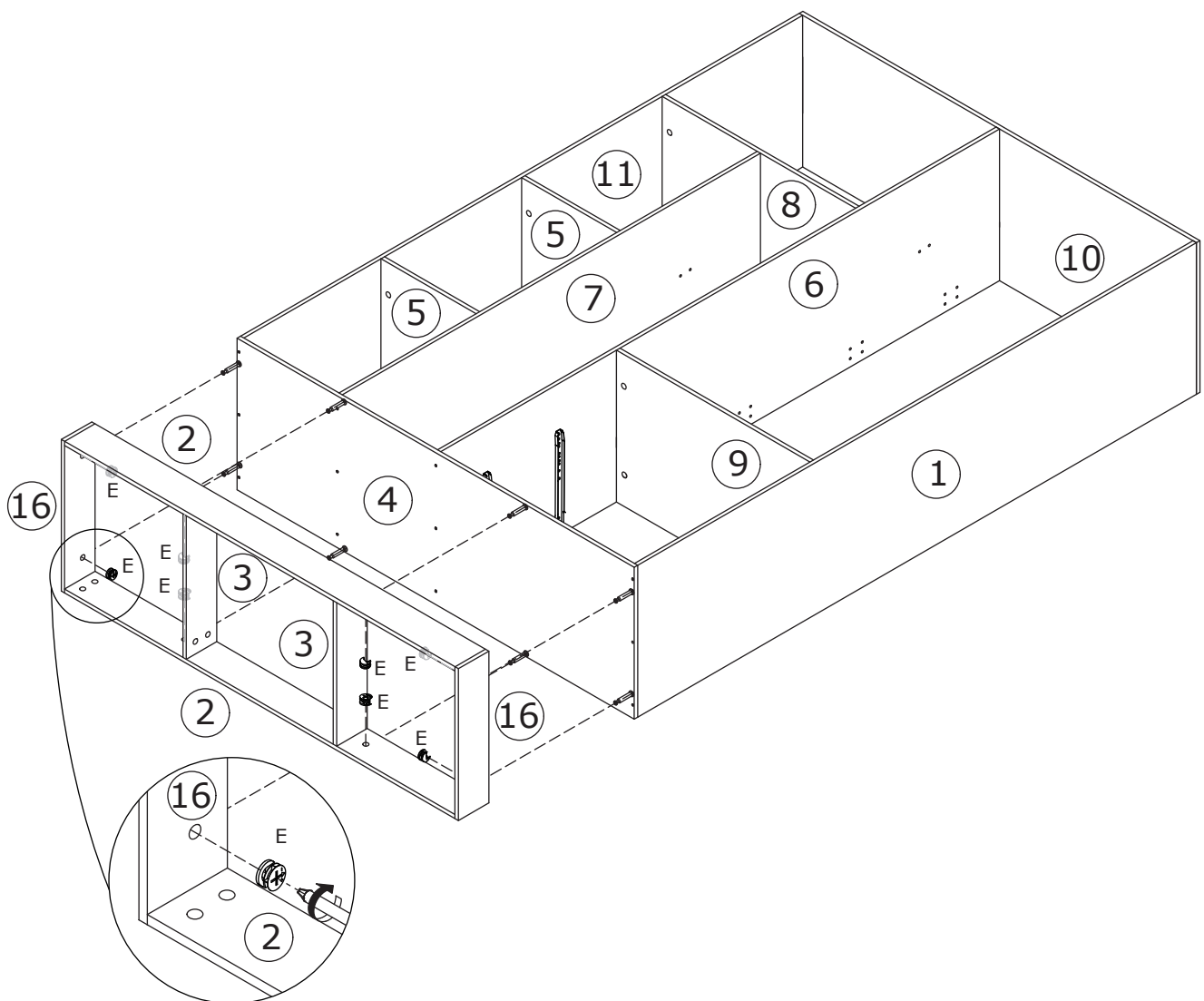

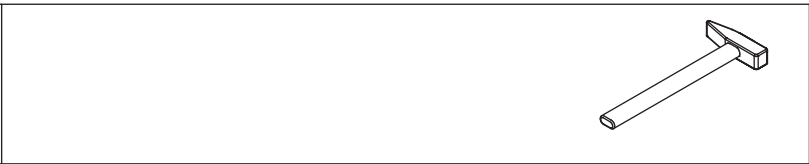
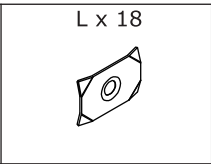
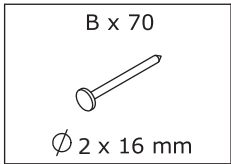

22

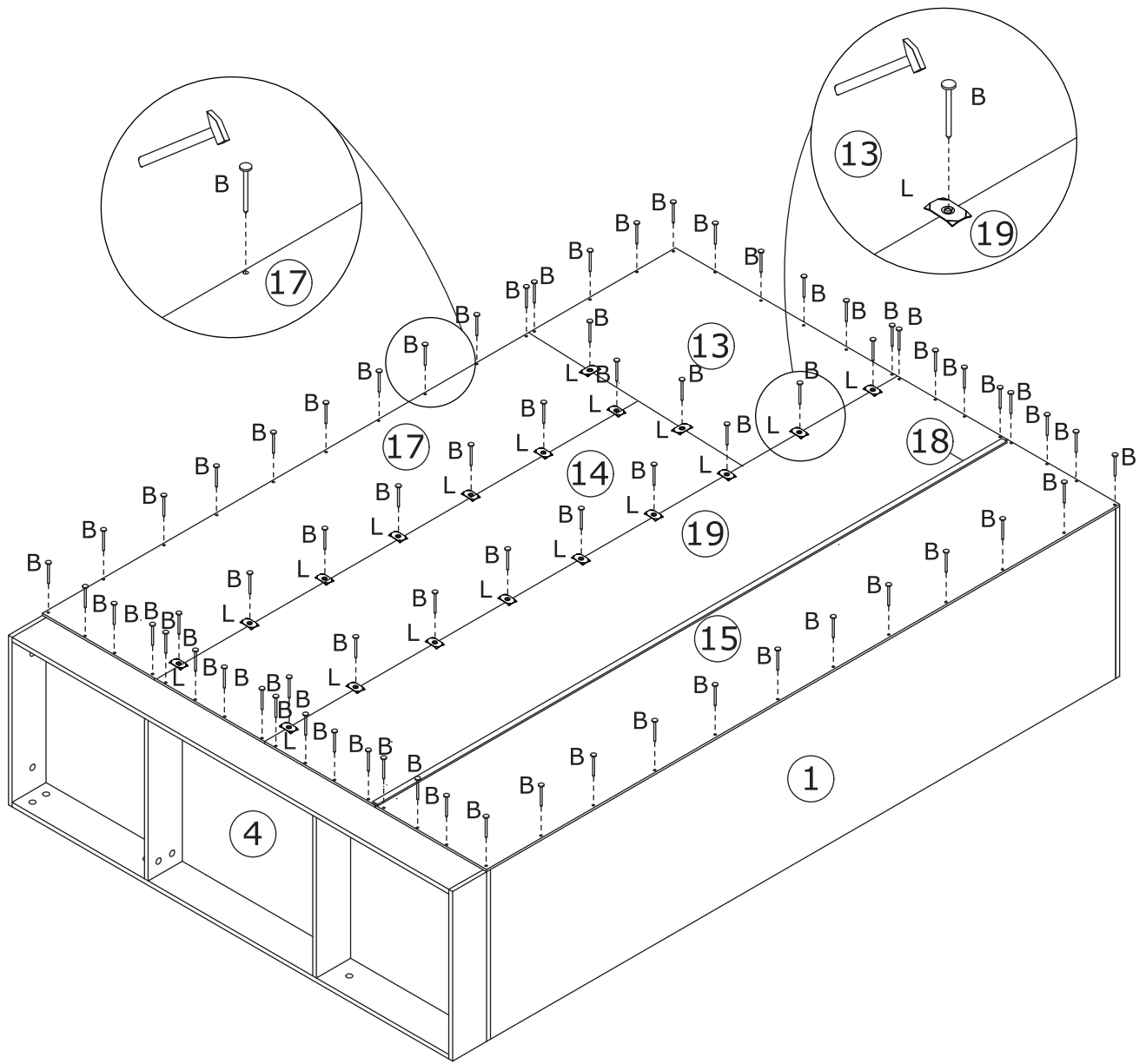

Connect board 19,15 with strip 18 as shown.
Fix back board 17,13,14,15 and 19 to the cabinet using nail(B) as shown.
Fix each board 17,13,14, and 19 together using part(L) with nail(B) as shown.

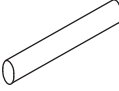
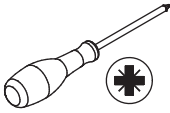

23

C x 4 	Q x 8  CRD3514A	M x 1  768 mm	K x 1  374 mm	
--	--	--	---	---

Fix part(C) to board 1,6 and 7 with screw(Q) as shown.
Put the clothing rods(M&K).

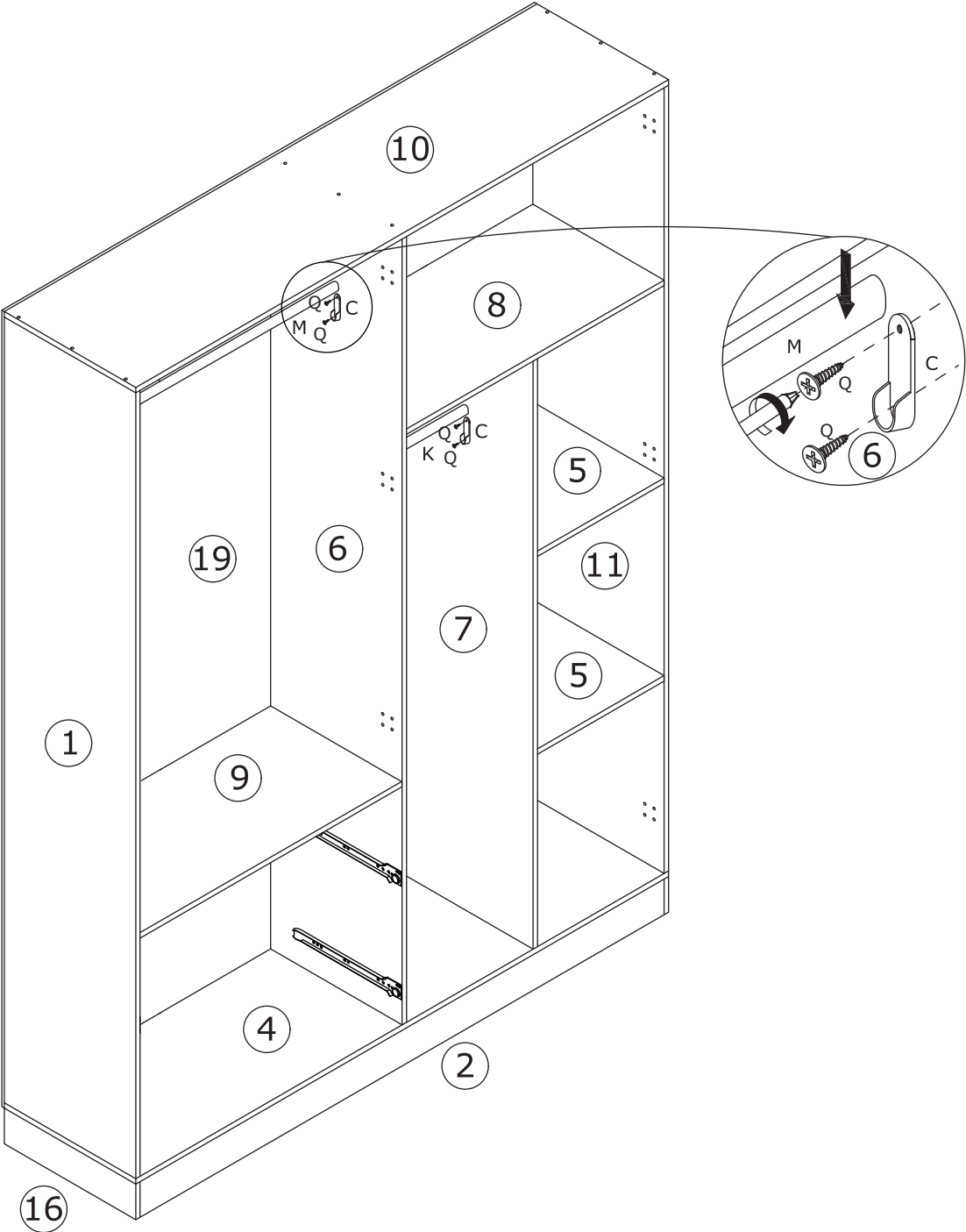



Please note, here are two different types of hinges.

The **full coverage door hinges(H)** are used on **outermost door panel**.

The **curved door hinges(I)** are used on the door panel in **the middle of** the cabinet.

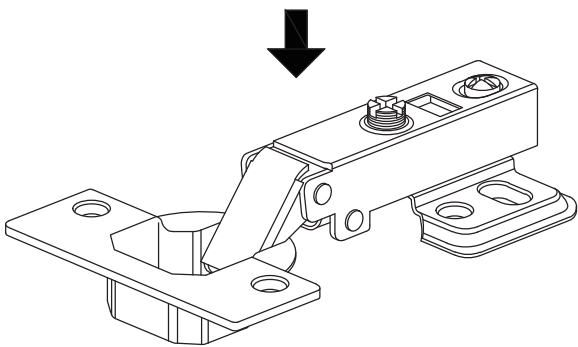

**H**

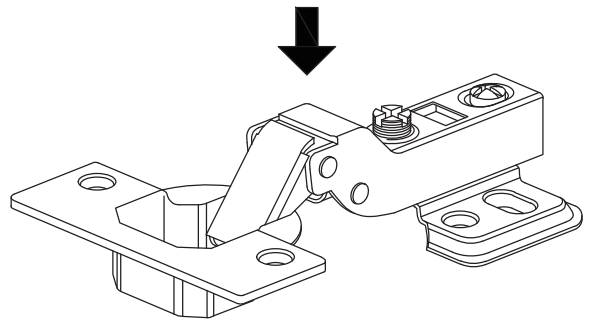
Full overlay hinge

**I**

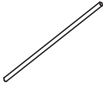
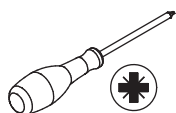

Half overlay hinge

25

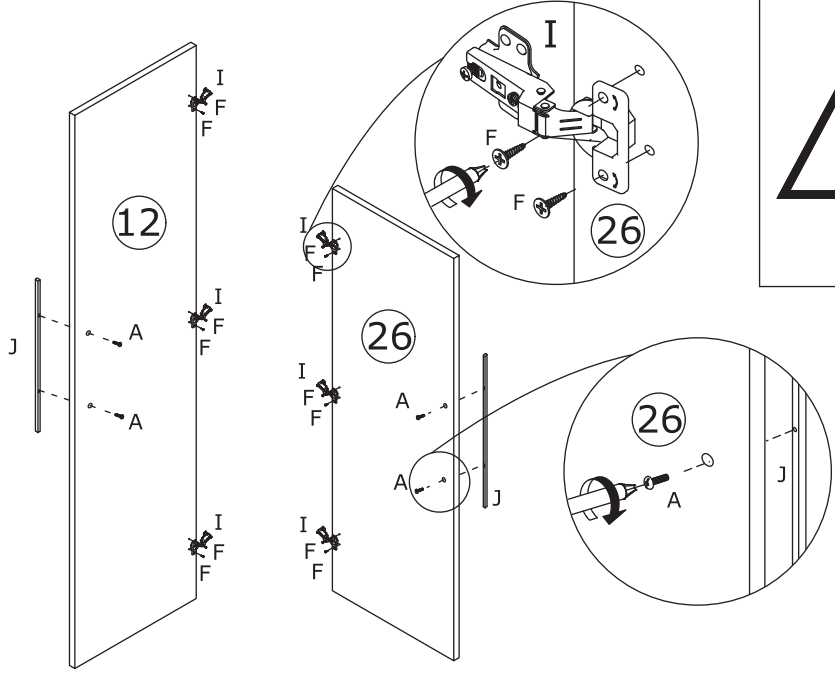
A x 4  CRE0420A	F x 12  CRD0416A	I x 6  DGA861B	J x 2  400 mm	
--	---	---	---	---

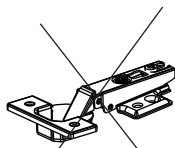

H I





DGA861A DGA861B

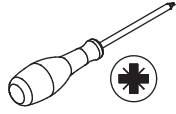

Fix hinge(I) to board 12 and 26 using screw(F), fix handle(J) using screw(A) as shown.

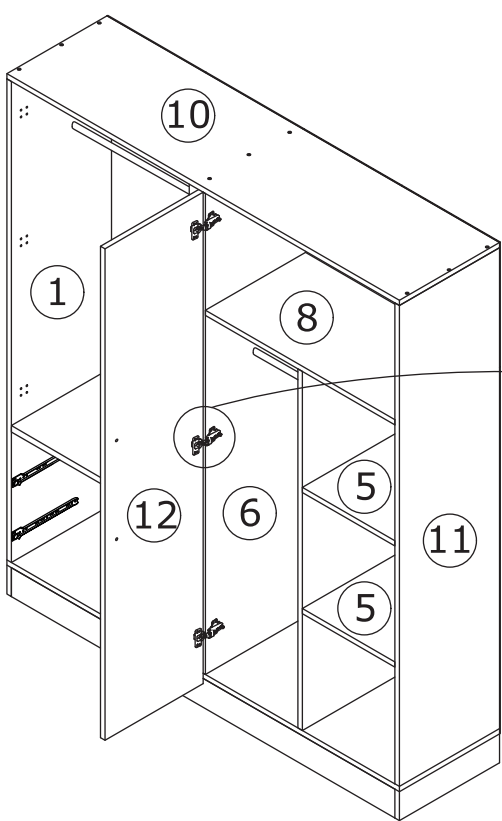
26

F x 12  CRD0416A	
---	---

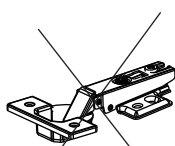

H I



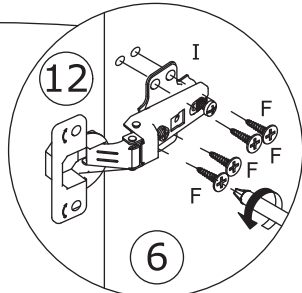

DGA861A DGA861B

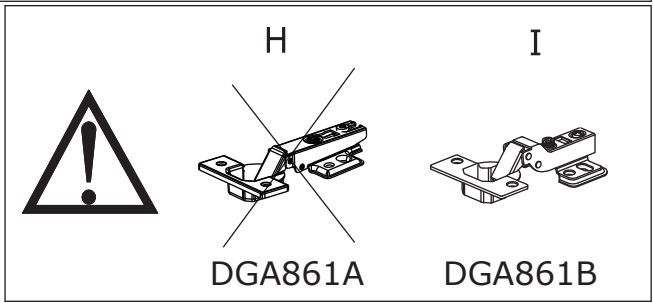
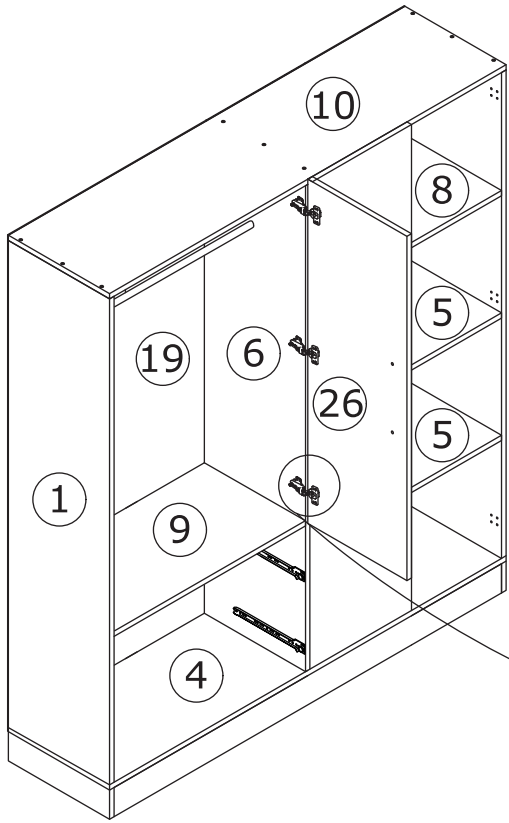
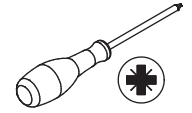
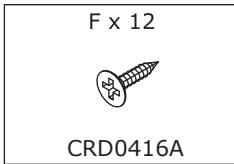

Attach board 12 to right of board 6 by fixing hinge(I) with screw(F) as shown.

27



Attach board 26 to left of board 6 by fixing hinge(I) with screw(F) as shown.

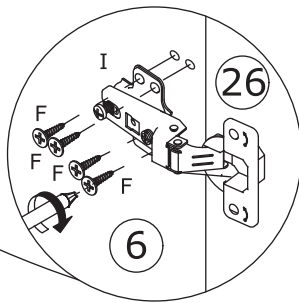

28

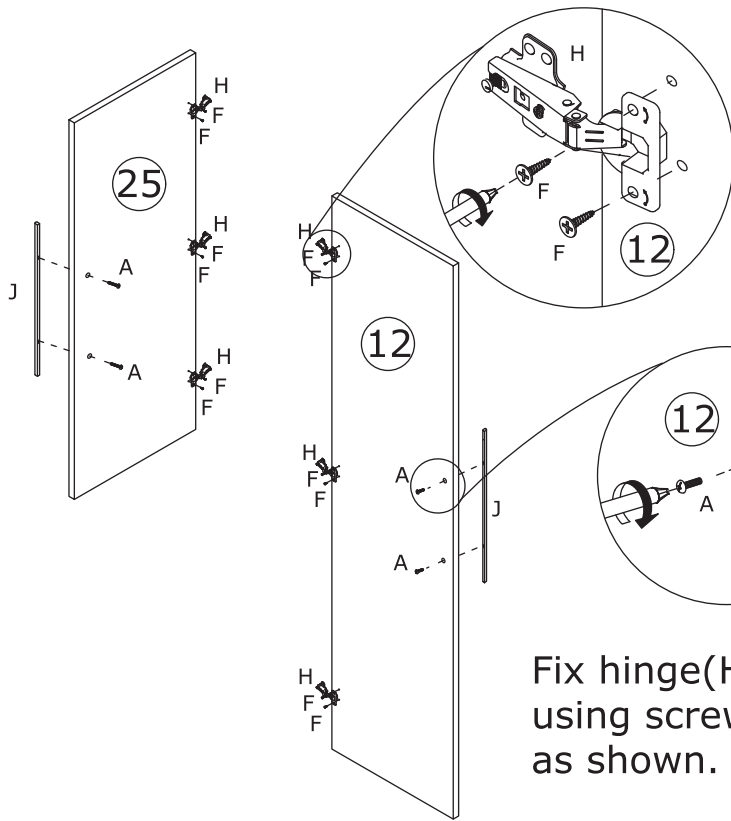
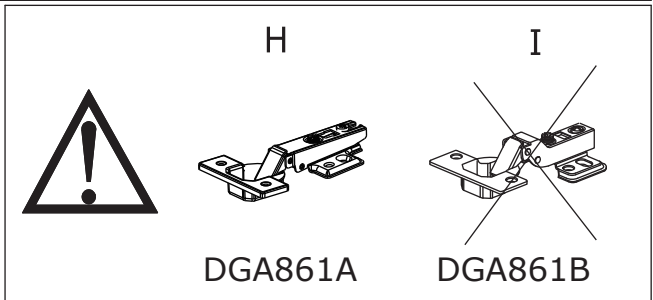
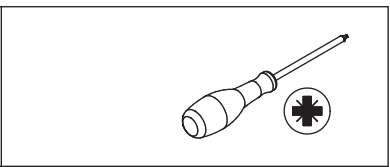
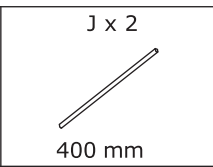
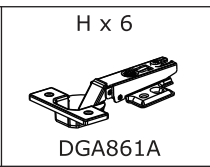
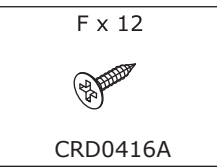
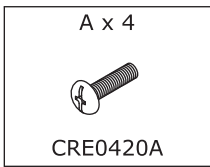

Fix hinge(H) to another board 12 and 25 using screw(F), fix handle(J) using screw(A) as shown.

29

F x 24
CRD0416A

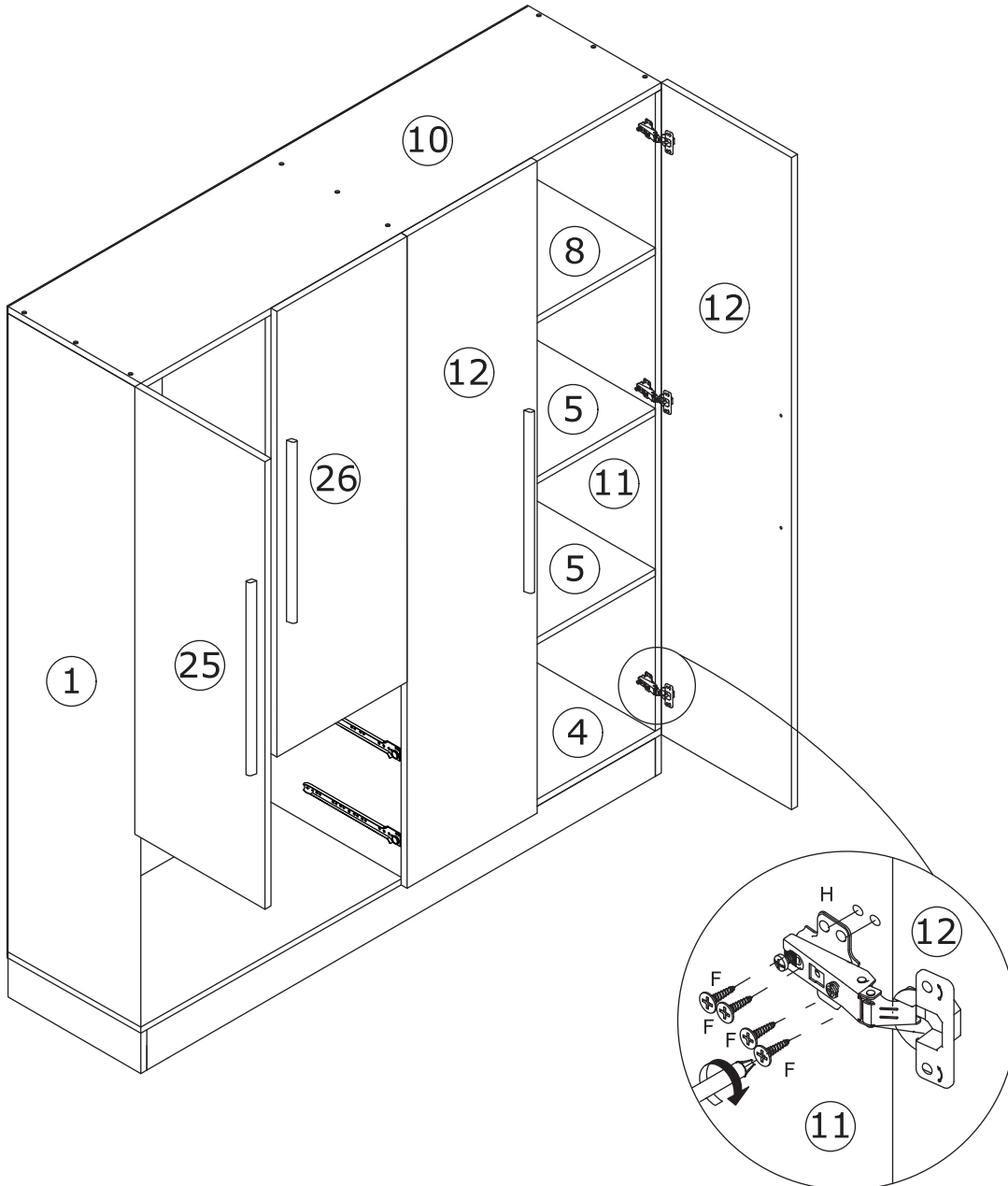
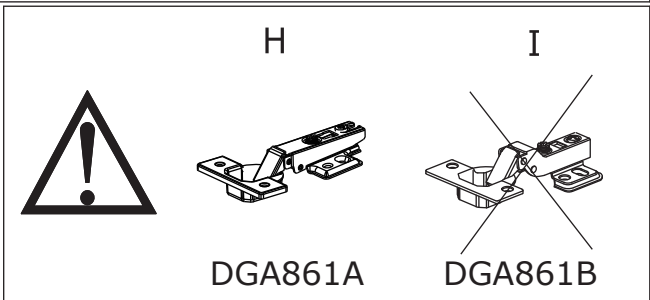
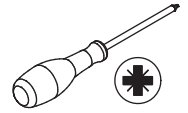

Attach board 25 to board 1, attach another board 12 to board 11 by fixing hinge(H) with screw(F) as shown.

30

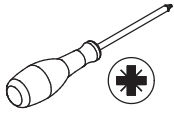

Insert eccentric rod (G) into board 20 as shown.

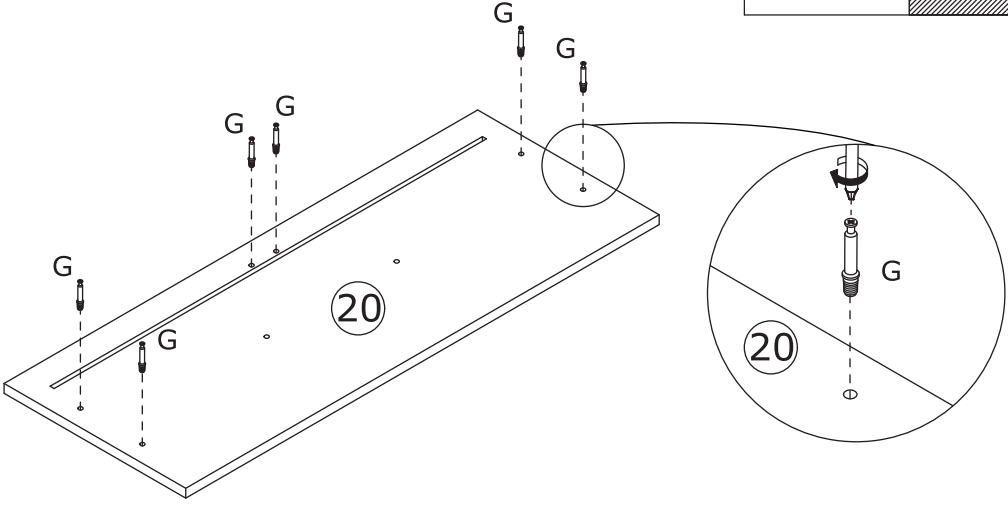
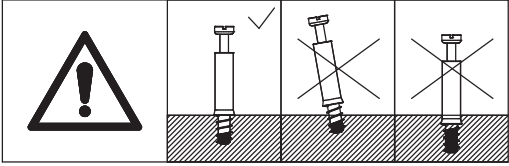

x2

31

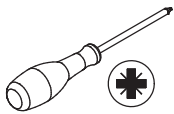
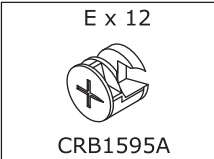

Attach board 21 and 23 to board 20, put cam lock(E) into holes in board 21,23 and turn clockwise to tighten as shown.

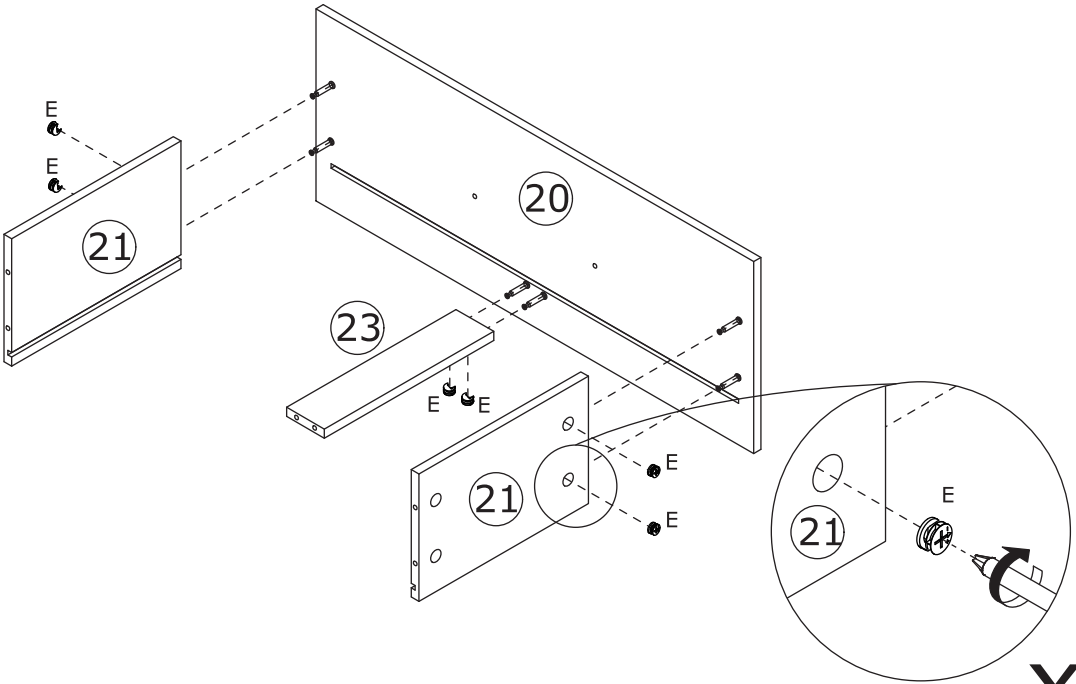
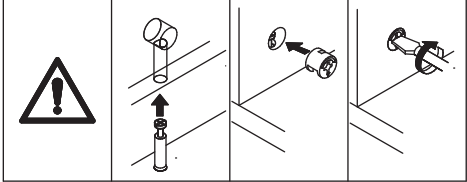

x2

32

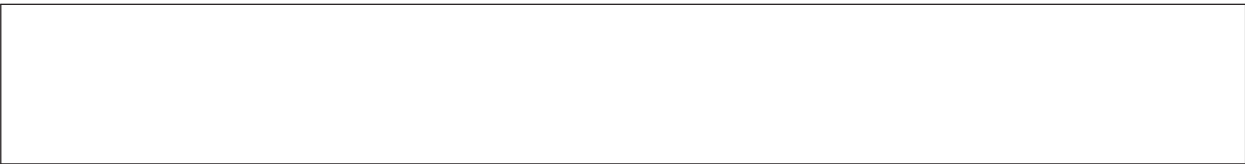

Slide board 24 along grooves as shown.

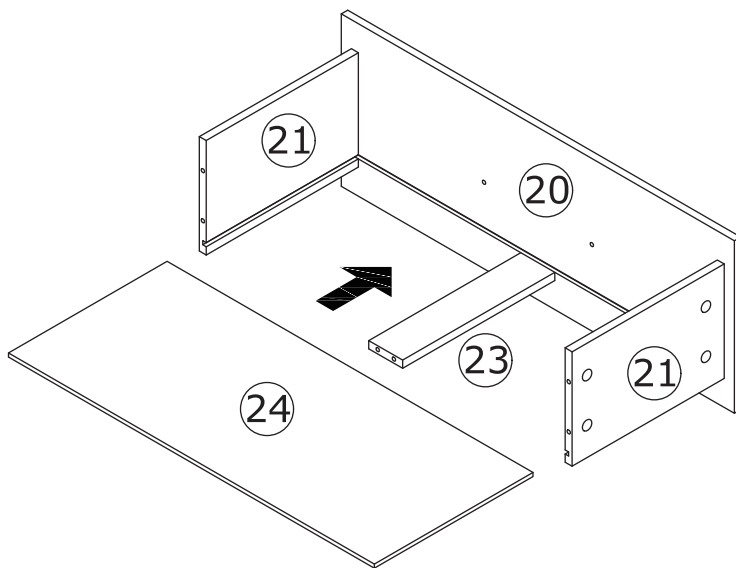

x2

33

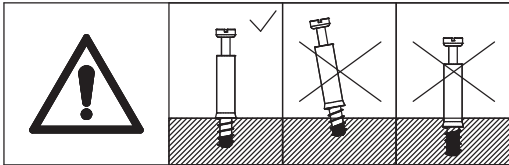
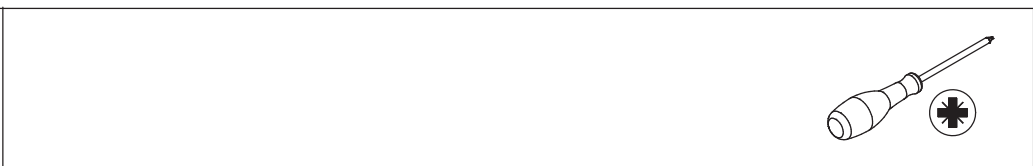
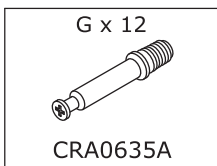

Insert eccentric rod (G) into board 22 as shown.

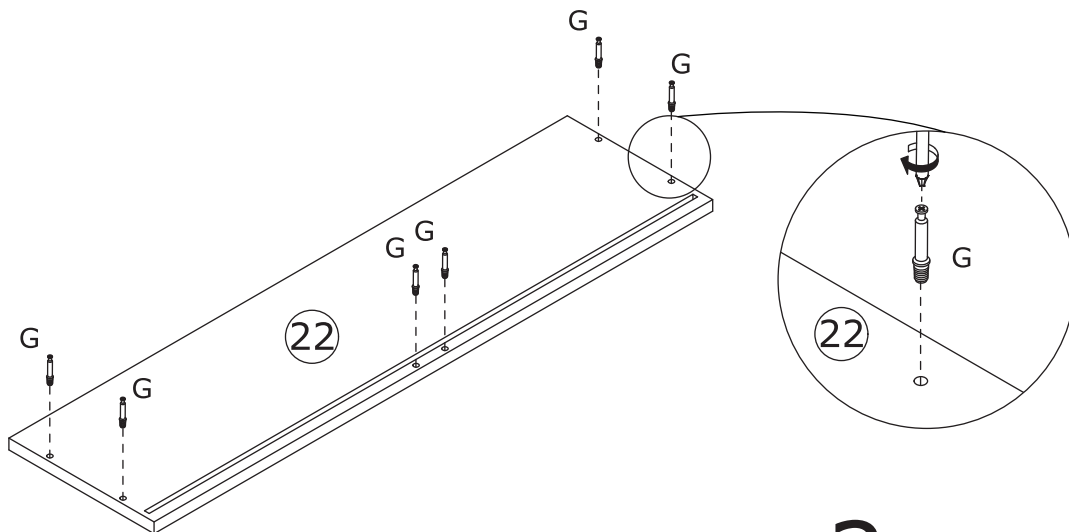

x2

34

E x 12
CRB1595A

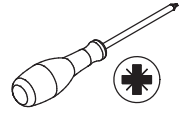

Attach board 22 to the drawer component, put cam lock(E) into holes in board 21,23 and turn clockwise to tighten as shown.

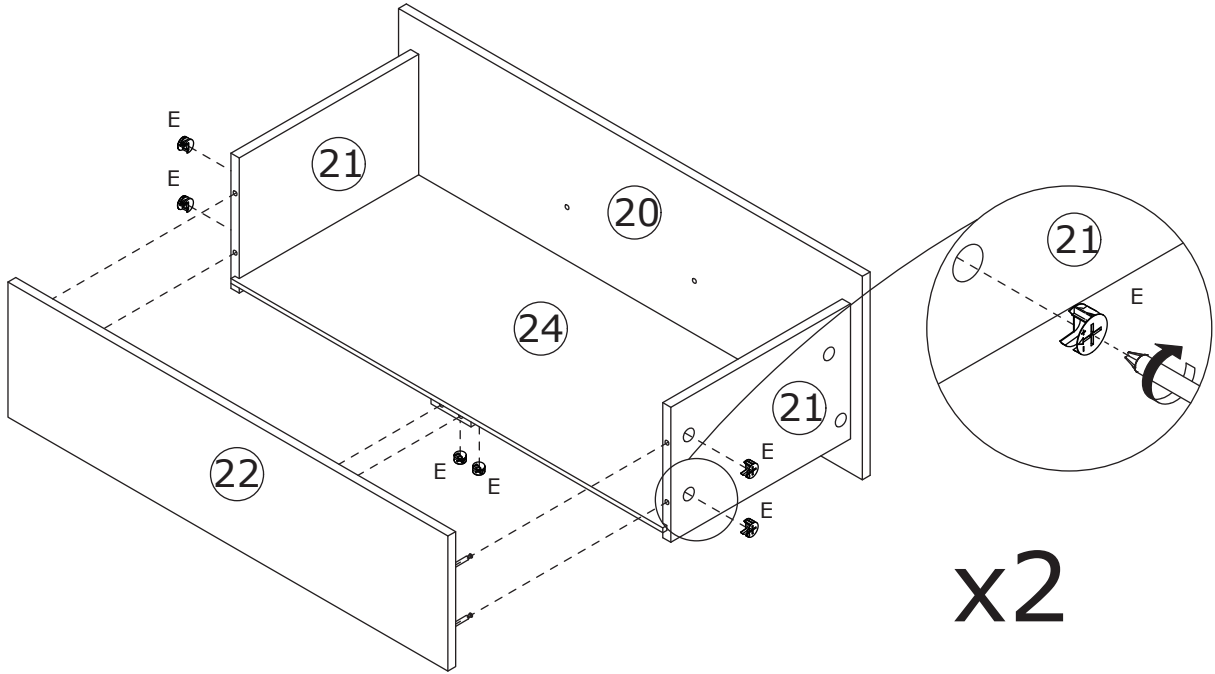
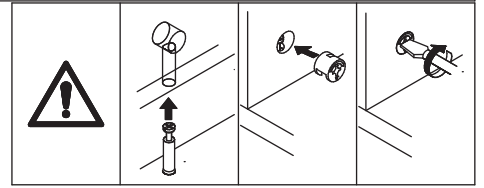

x2

35

A x 4
CRE0420A

N x 2
200 mm

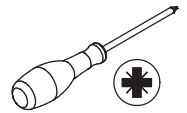

Fix handle(N) to board 20 using screw(A) as shown.

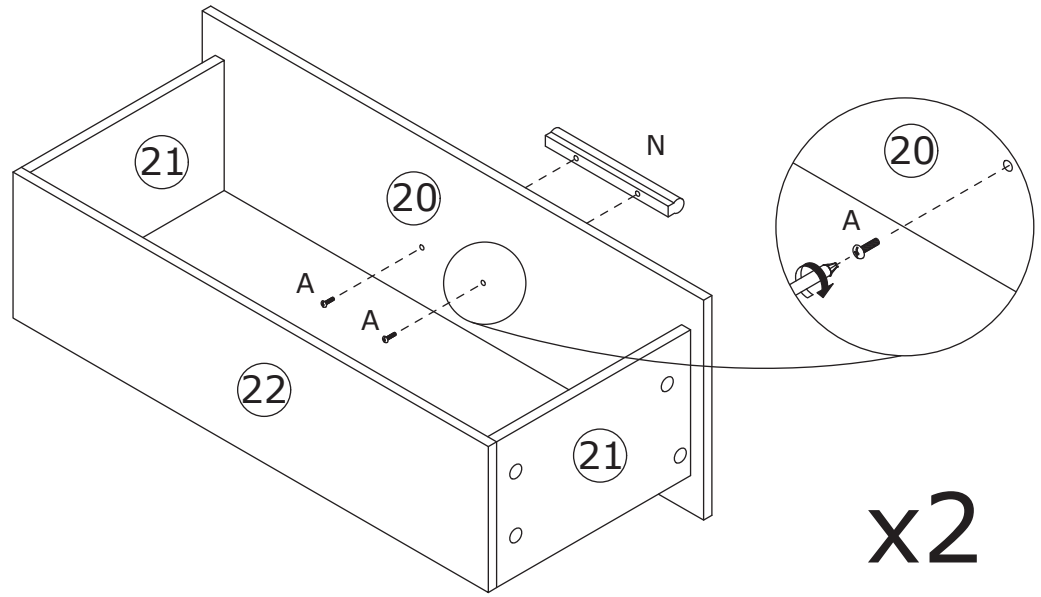

x2

36

Q x 8



CRD3514A

O x 2



WX0816A

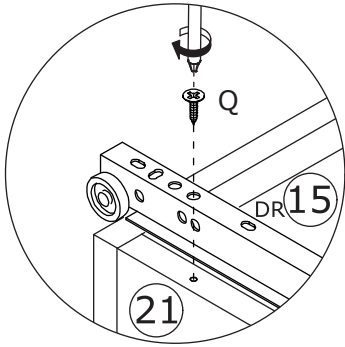
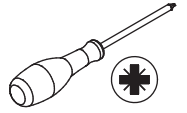

Fix runner(DL) and (DR) to drawer side using screw(Q) as shown.

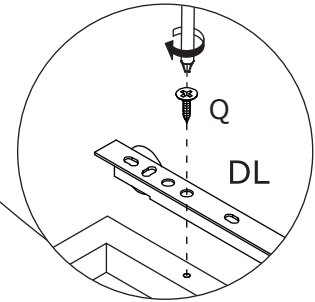
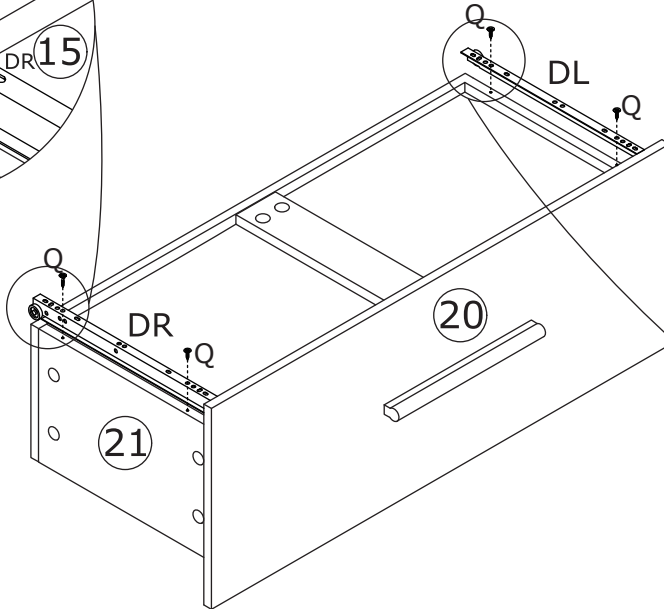
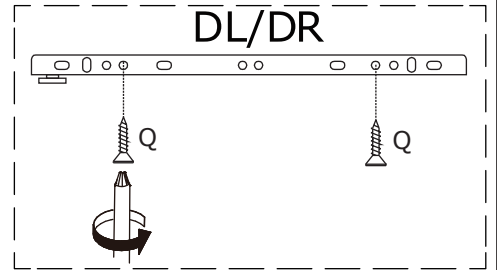

x2

37

Align rails, slide drawers.

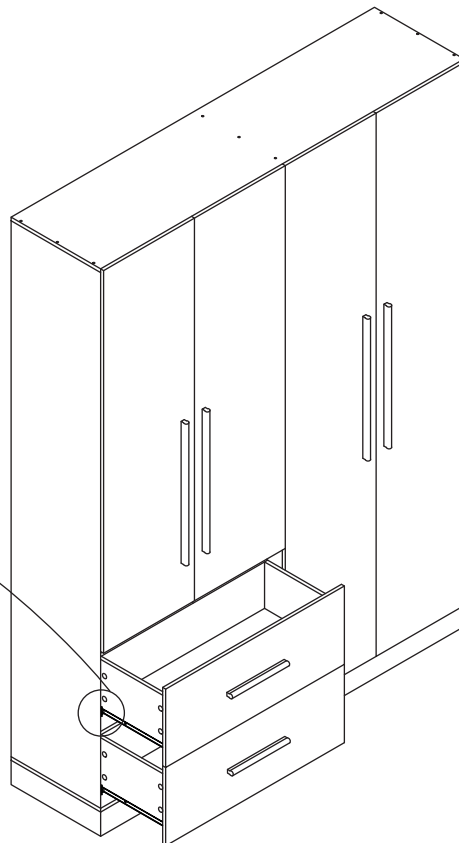
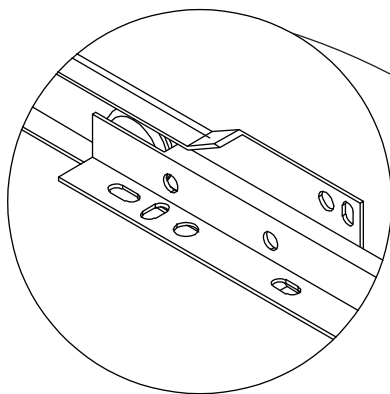

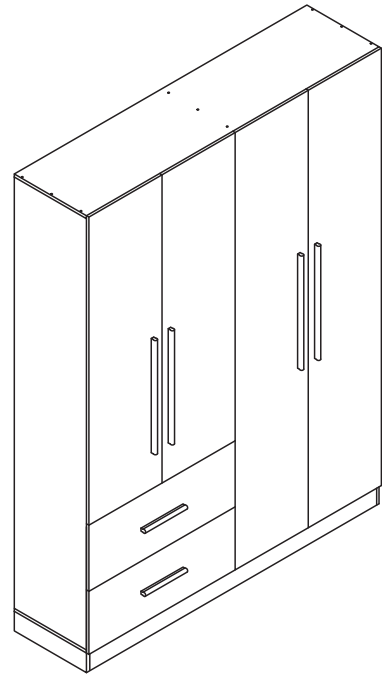
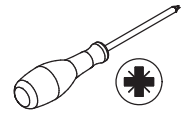

If doors are still not aligned if the hinges are properly correctly, please watch the video.

If there is misalignment after you install, adjust the screw to the best condition

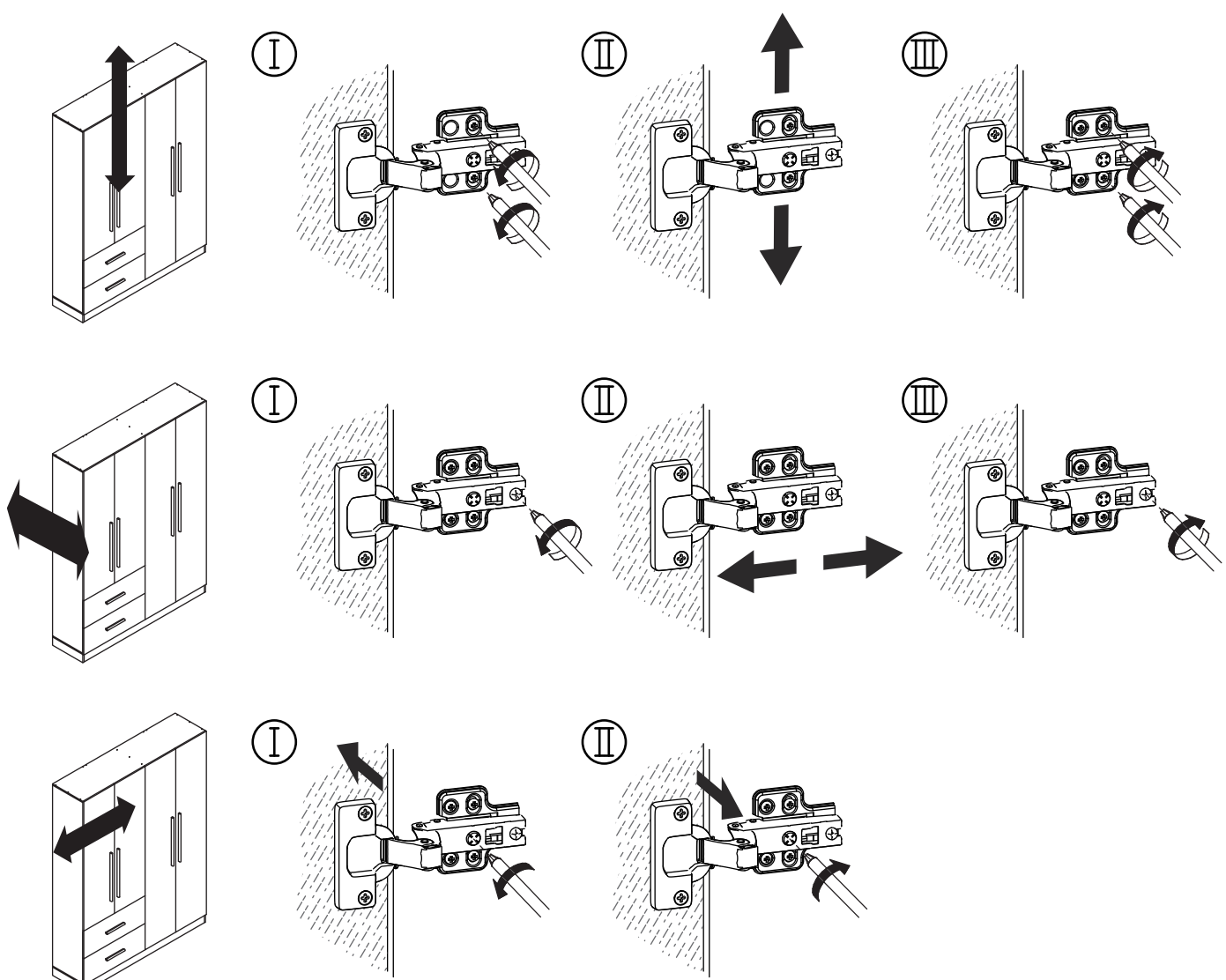

39

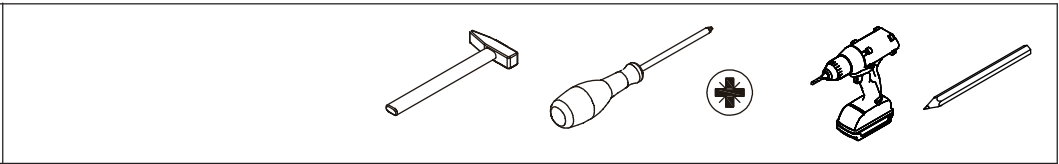
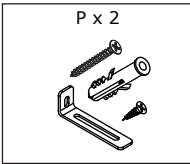

Install anti-tipping device(P) as shown.

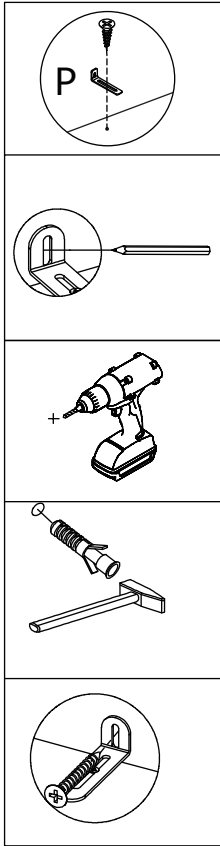
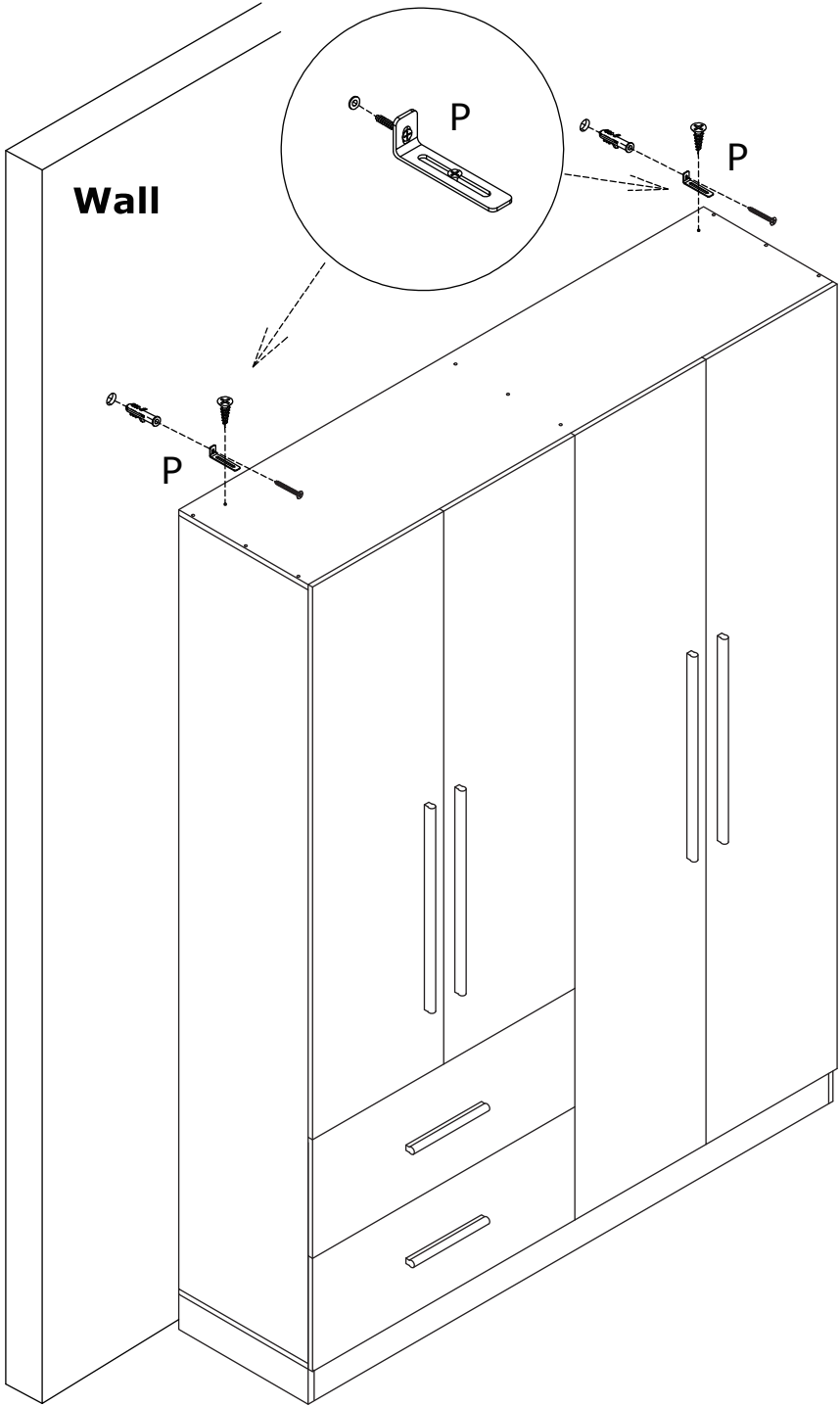

WARRANTY

WARRANTY CLAIMS

- There is a 30-day warranty for broken furniture or any other problems that do not work properly. The warranty will start from the date of purchase which must be verified by proof of purchase.
- Before making a claim, we may be able to answer your query, simply call us. Please leave your purchase order number, along with some details of the problem, if you want a replacement part. We will arrange within 48 hours. If there is out of stock, we will reply with a shipping date.
- The product must be used in accordance with the instructions provided. For health reasons.
- For other reasons, if the furniture needs to be returned, it must be cleaned and dried and operated within 30 days of receipt.

Type of Warranty Claim

- Failure to follow the furniture instructions will invalidate the warranty. Attention please.
- Does not include damage during installation, but includes damage during transportation.

Scope of responsibility

- Shall not bear any responsibility for misuse or user damage and / or loss of parts during the installation of furniture.
- After using, the damage and scratches of the furniture are not covered by the warranty.

The Warranty Relates to All Bought in The Us and Covers The Following Areas

- Sheet parts: 1 month from the date of purchase.
- Electrical parts: 1 month from the date of purchase.