

User's Manual

F/Q/K/CK

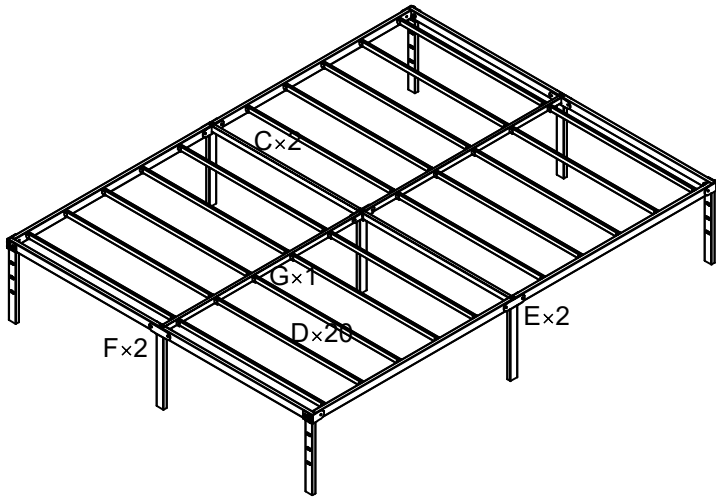

Give us the chance to do better for you !

If you have any questions about the product, please don't hesitate to contact us. You can reach us through your order. Thanks for your support !

Components

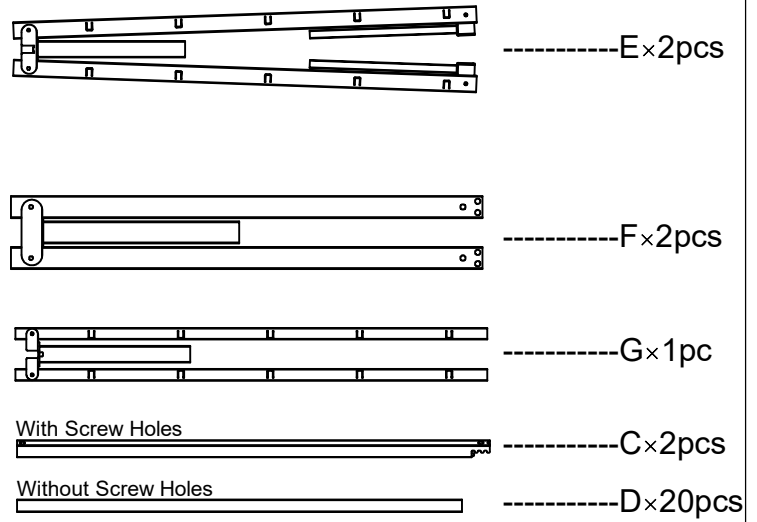

Screws & Tools

L	S	O	J	N	R
M8*37	M8*29	M8	M8*35	Allen key	Wrench
8pcs	4pcs	4pcs	5pcs	1pc	1pc

Step 1

Unfold and layout E as shown

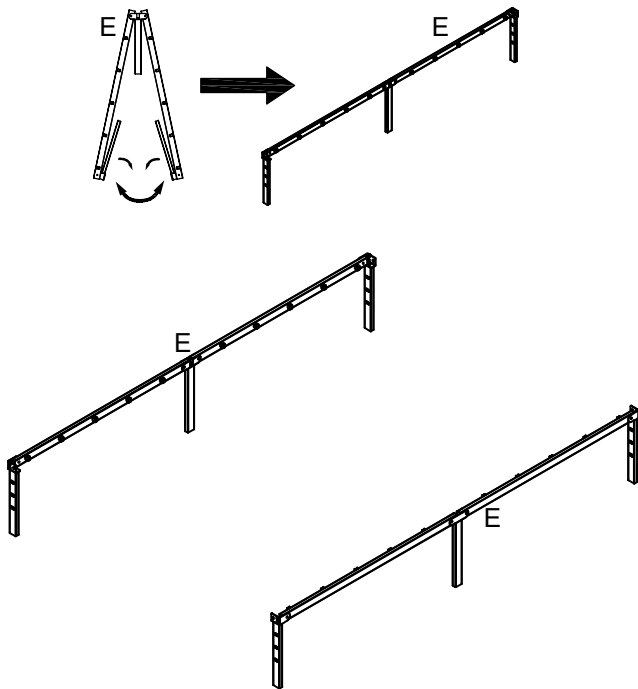

Note:
For easy setup intention, do not tighten screws during the installation process.

Step 2

Unfold and layout F as shown

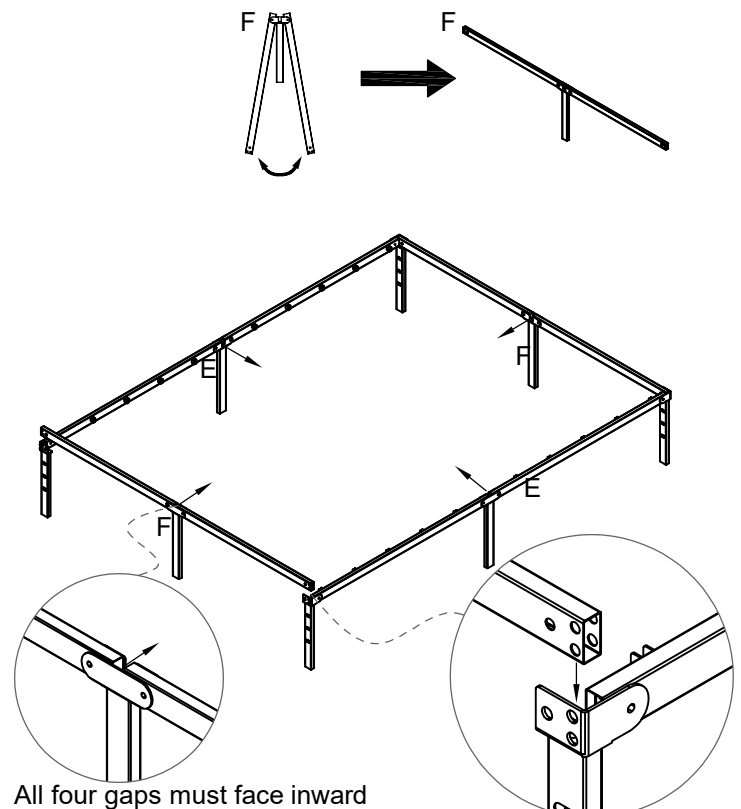

Step 3

Join E to F with bolt L and (bolt S+Nut O) as shown

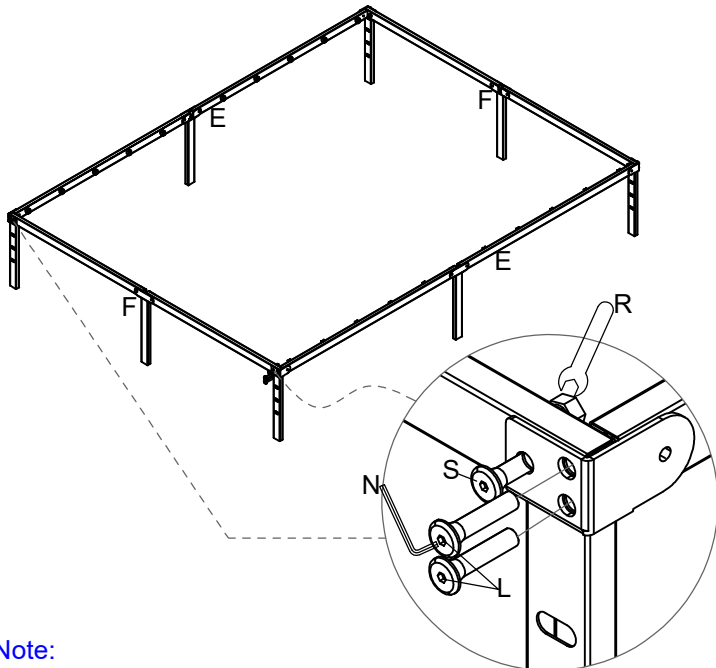

Note:
When tightening S and O, please use N to hold S screw head on one end while using R to tighten Nut O on the other end, Please do not use your hand alone to tighten O as it may not tum O properly.

Step 4

Unfold and layout G as shown

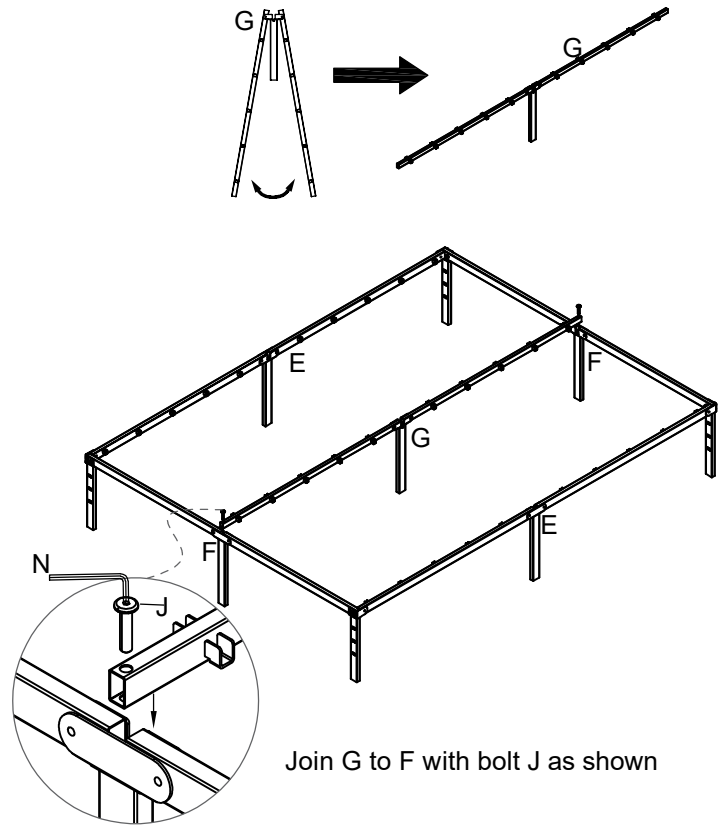

Join G to F with bolt J as shown

Step 5

The two parts labeled C join together first as shown, then fastened with screw J to connect C and G

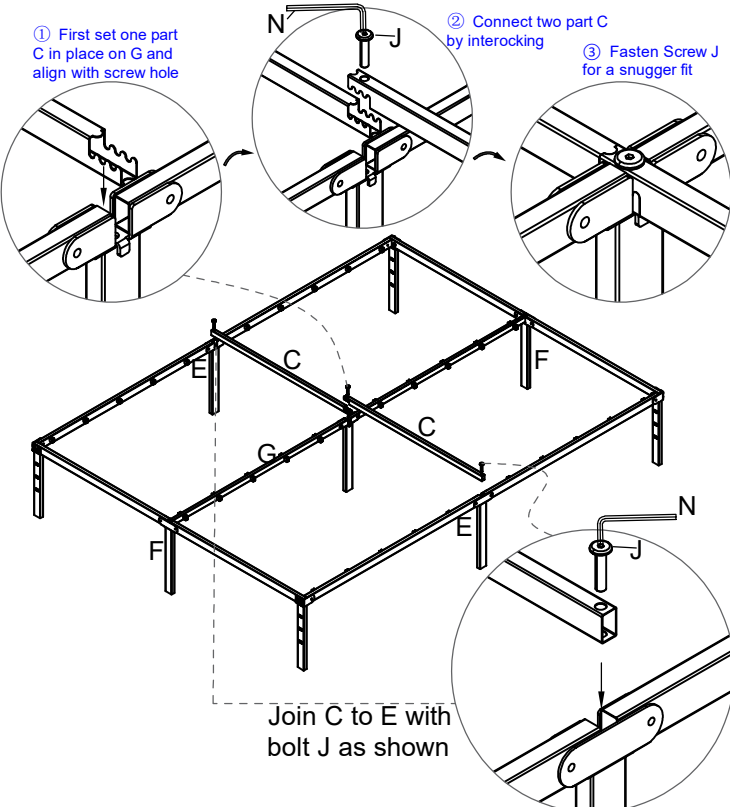

Step 6

Insert 20 D slats Complete

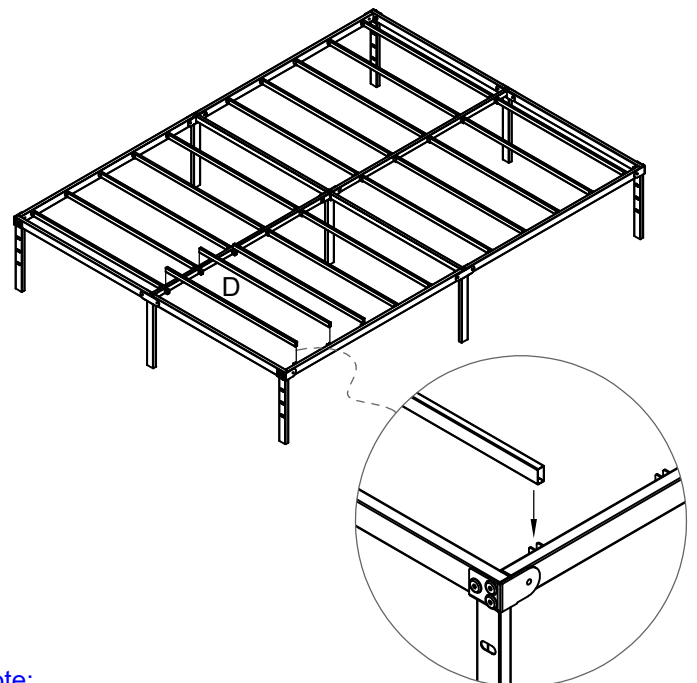

Note:
In the last step, please make sure all the screws are tightened

User's Manual

Twin/Twin XL

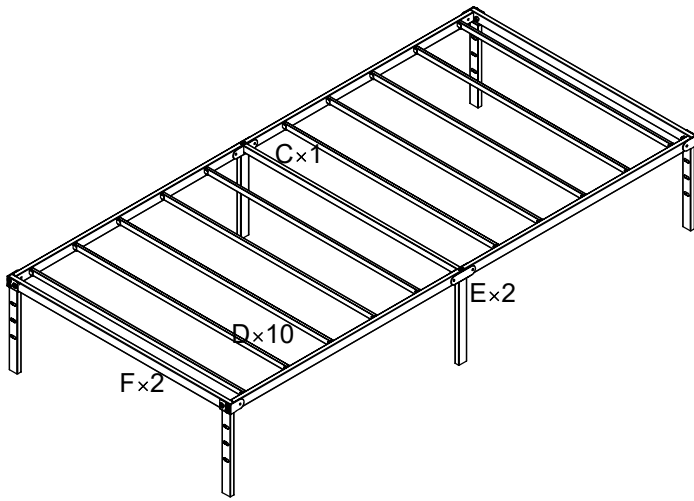

Give us the chance to do better for you !

If you have any questions about the product, please don't hesitate to contact us. You can reach us through your order. Thanks for your support !

Components

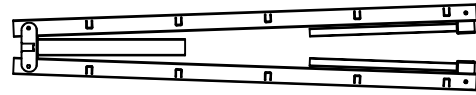

-----E×2pcs

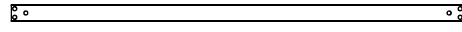

-----F×2pcs

With Screw Holes

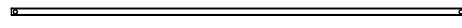

-----C×1pc

Without Screw Holes

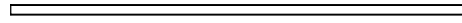

-----D×10pcs

Screws & Tools

L	S	O	J	N	R
M8*37	M8*29	M8	M8*35	Allen key	Wrench
8pcs	4pcs	4pcs	2pcs	1pc	1pc

Step 1

Unfold and layout E as shown

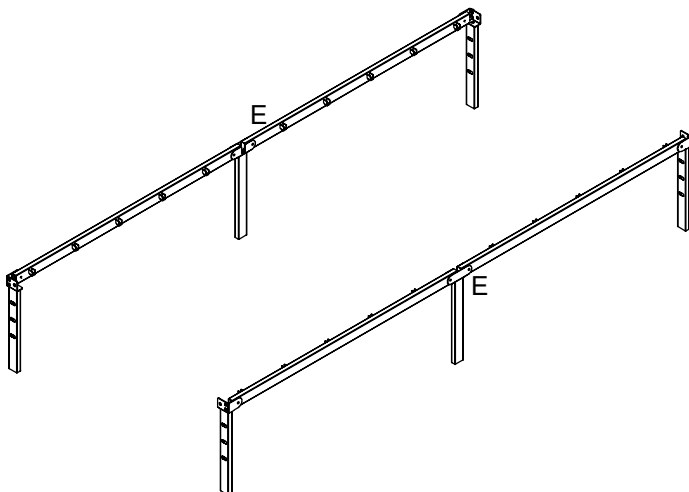
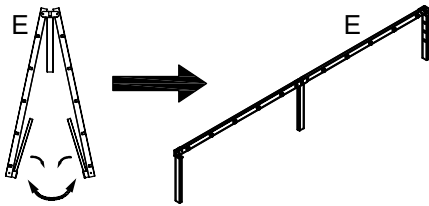

Note:
For easy setup intention, do not tighten screws during the installation process.

Step 2

Select F as shown

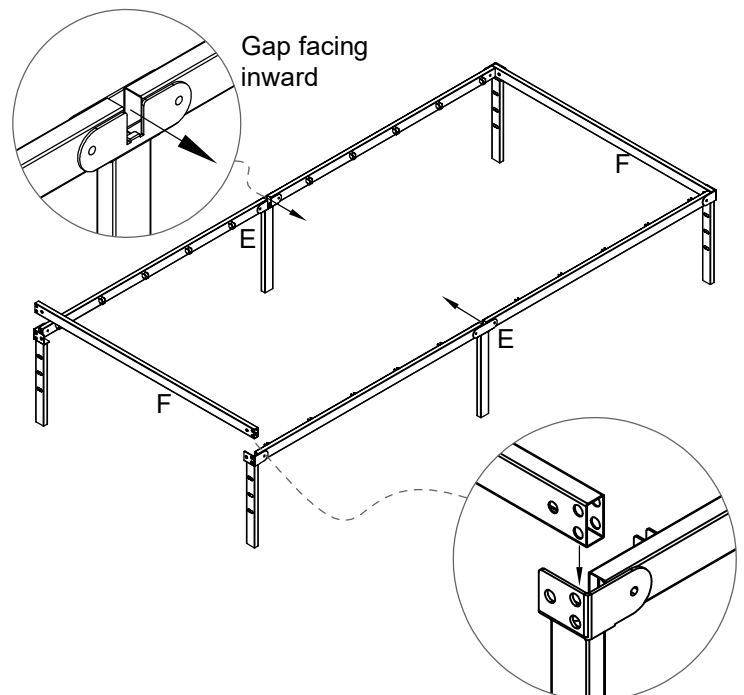
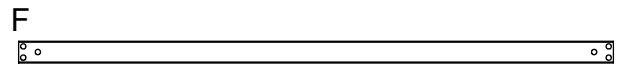

Step 3

Join E to F with bolt L and (bolt S+Nut O) as shown

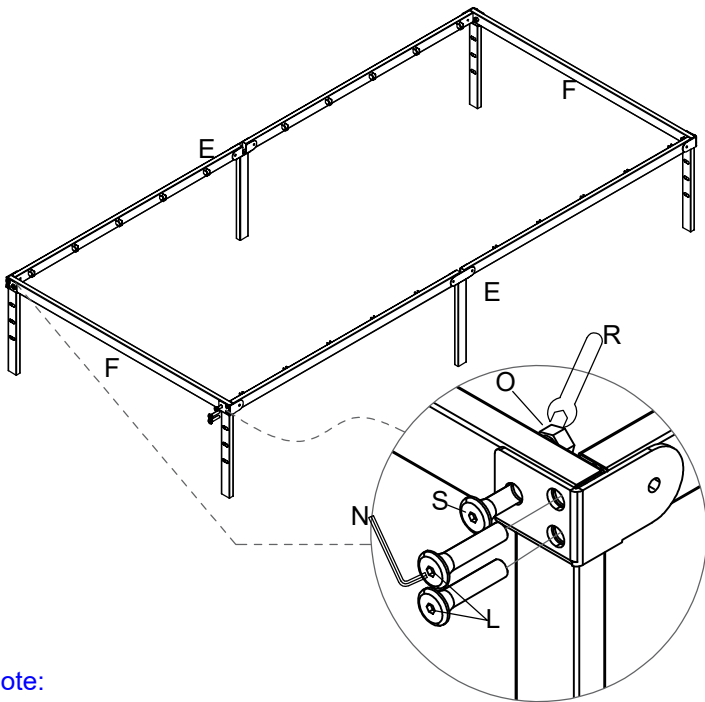

Note:
When tightening S and O, please use N to hold S screw head on one end while using R to tighten Nut O on the other end, Please do not use your hand alone to tighten O as it may not tum O properly.

Step 4

Fastened with screw J to connect C and E

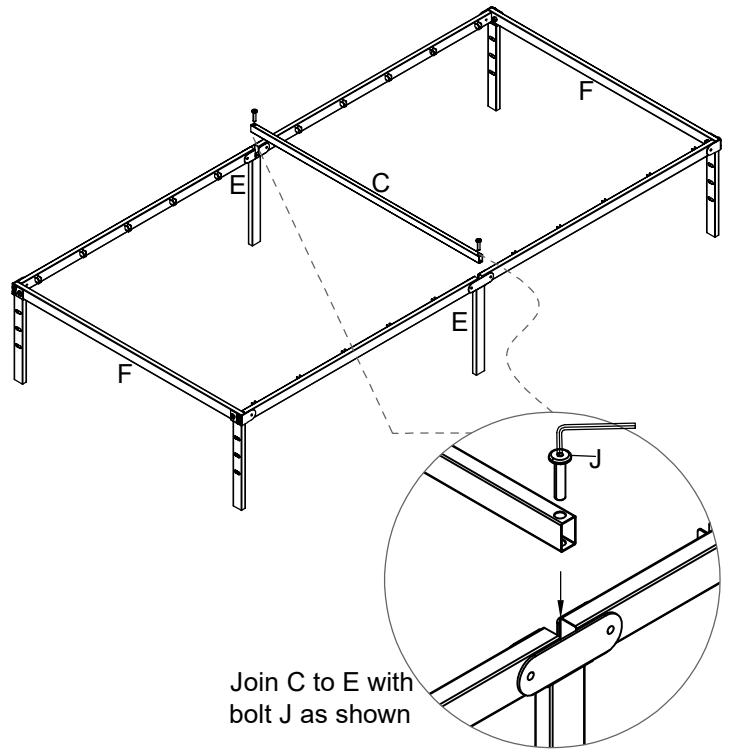

Join C to E with bolt J as shown

Step 5

Insert 10 H slats Complete

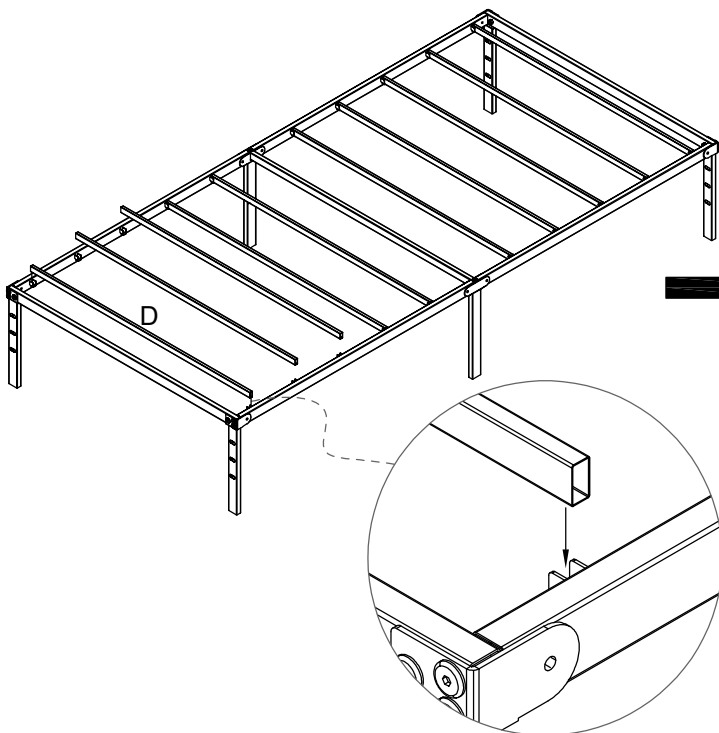

Insert 10 D slats Complete

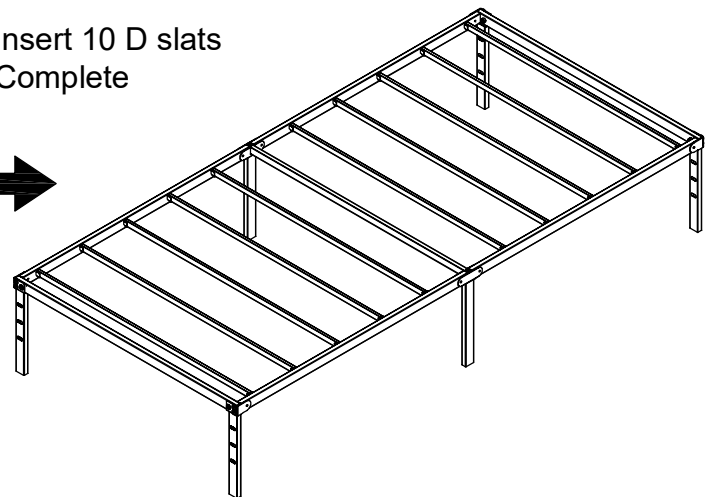

Note:
In the last step, please make sure all the screws are tightened