

# Installation & Assembly

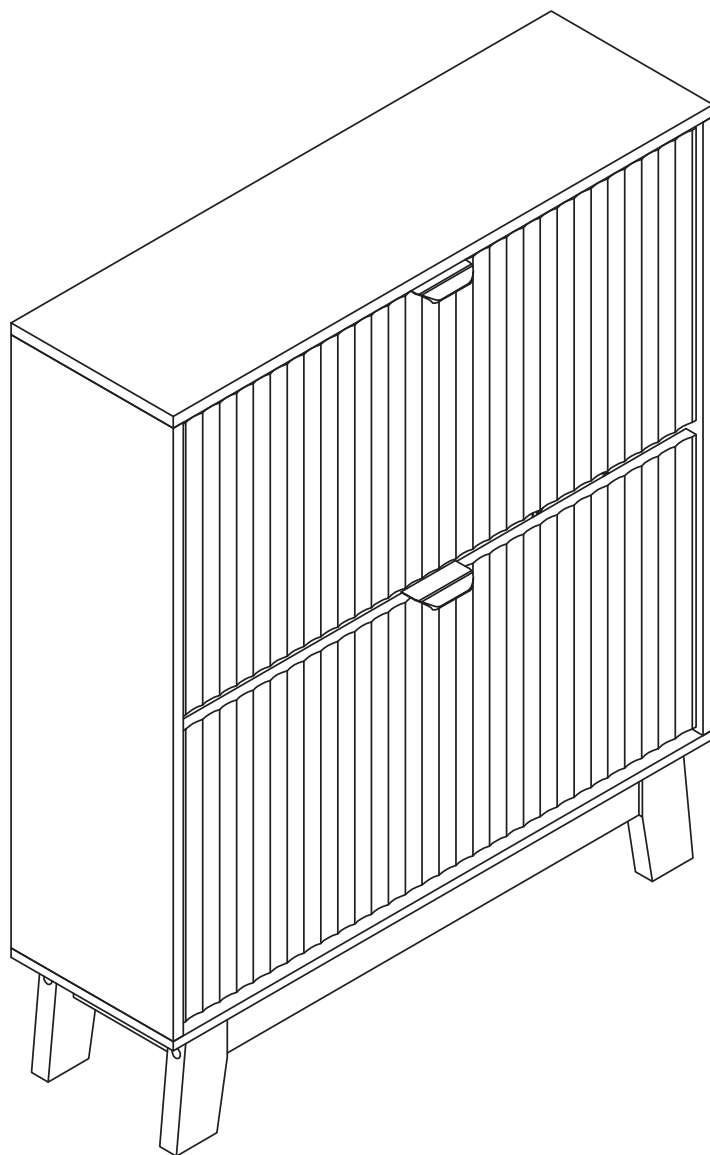

Version:1.0

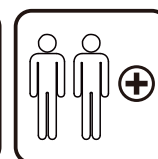
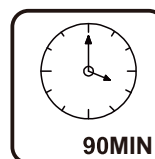
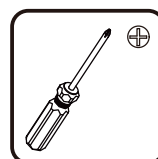
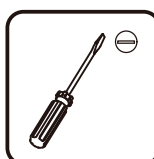

**EN\_IMPORTANT, RETAIN FOR FUTURE REFERENCE: READ CAREFULLY.**

**USING CAM LOCK AND QUICKFIT**

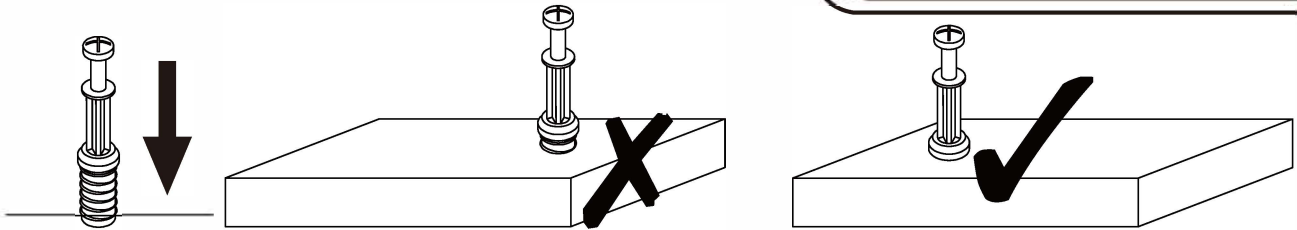

**EN\_QUICKFIT:** Tighten quickfit until shoulder is flush with panel. Do not overtighten or undertighten.

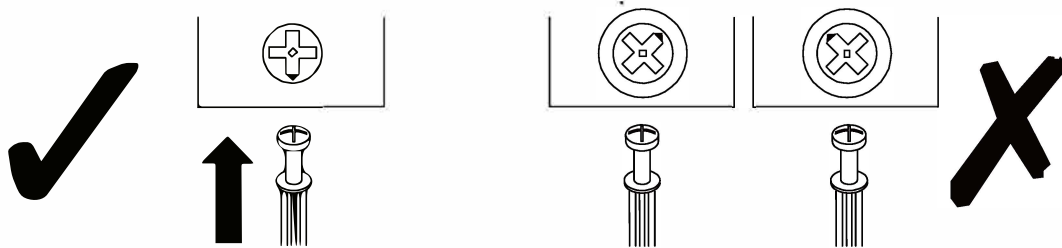

**EN\_CAM LOCK:** When fitting cam lock, ensure starting position is correct before you insert connecting quickfit.

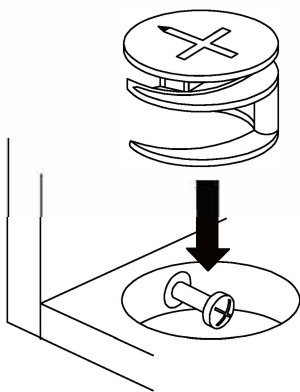

**EN\_Quickfit head** should be in the centre of the cam lock when the two panels are joined.  
Cam lock should be inserted before quickfit.

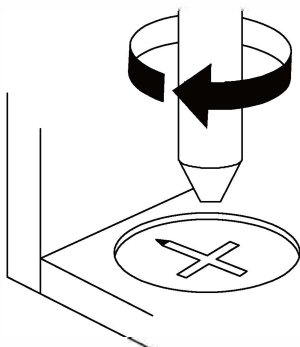





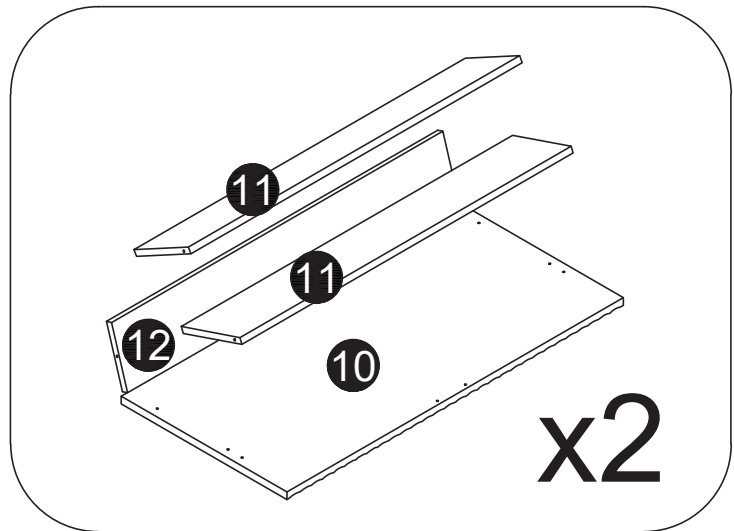
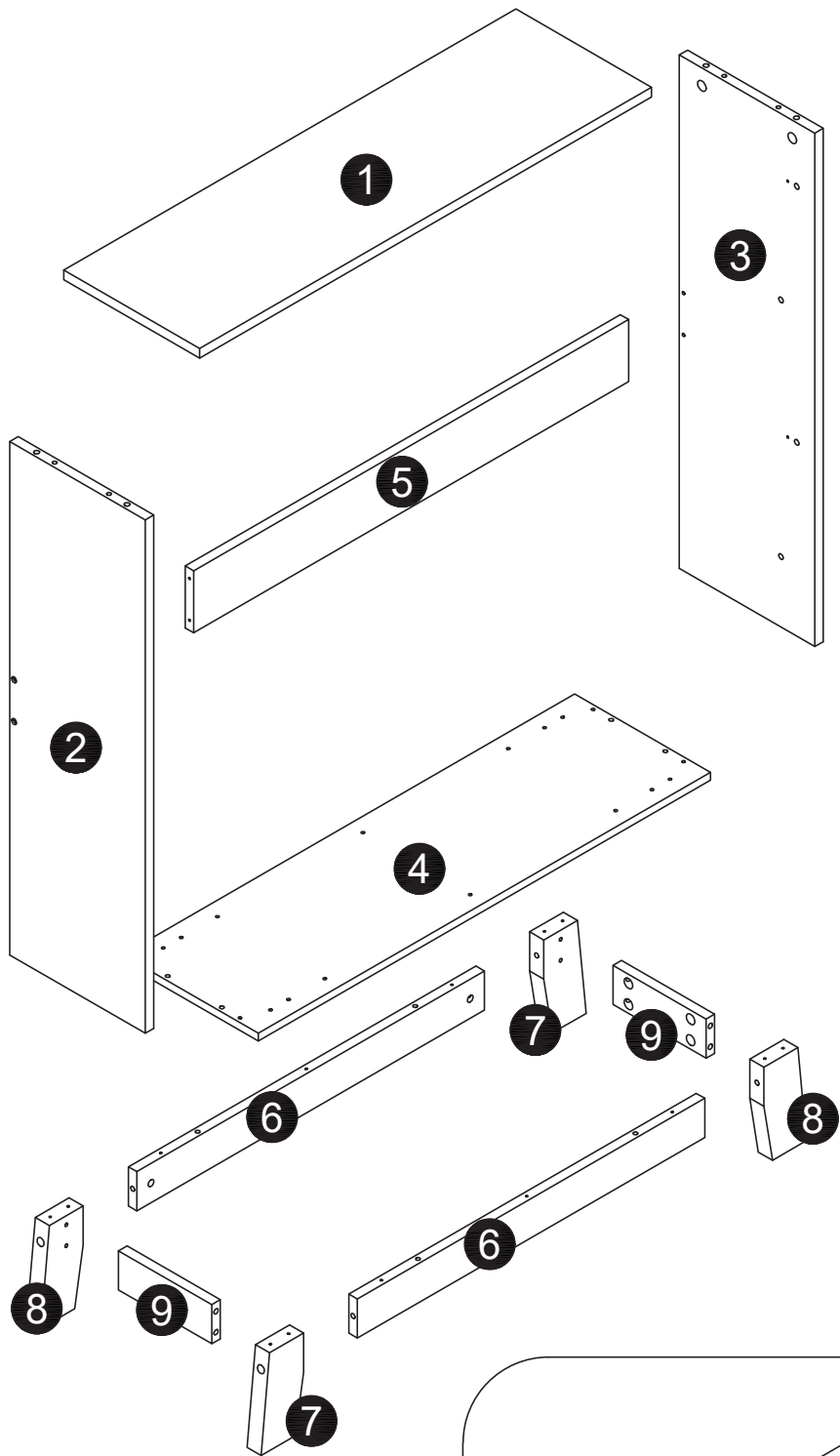



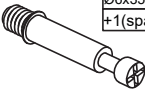

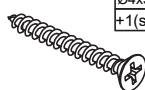

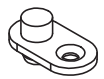



**EN\_Turn** cam lock clockwise to tighten.



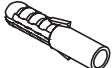

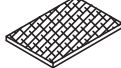
# HARDWARE

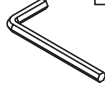
 <p><b>A</b> x12 Ø6x35mm +1(spare)</p>	 <p><b>B</b> x12 Ø15x10mm +1(spare)</p>	 <p><b>C</b> x12 Ø6x30mm +1(spare)</p>	 <p><b>D</b> x10 Ø4x35mm +1(spare)</p>	 <p><b>E</b> x32 Ø3.5x12mm +3(spare)</p>	 <p><b>F</b> x4</p>
 <p><b>G</b> x4</p>	 <p><b>H</b> x4</p>	 <p><b>I</b> x4</p>	 <p><b>J</b> x4</p>	 <p><b>K</b> x2</p>	 <p><b>L</b> x2</p>
  <p><b>M</b> x2 Ø4x14mm</p> <p>M-1 M-2</p>	 <p><b>N</b> x2 Ø6x30mm</p>	 <p><b>O</b> x8 15mm +2(spare)</p>	 <p><b>P</b> x4</p>	 <p><b>Q</b> x14 Ø4x30mm +1(spare)</p>	 <p><b>R</b> x2</p>
 <p><b>S</b> x1 M5</p>					

E x4

F x4

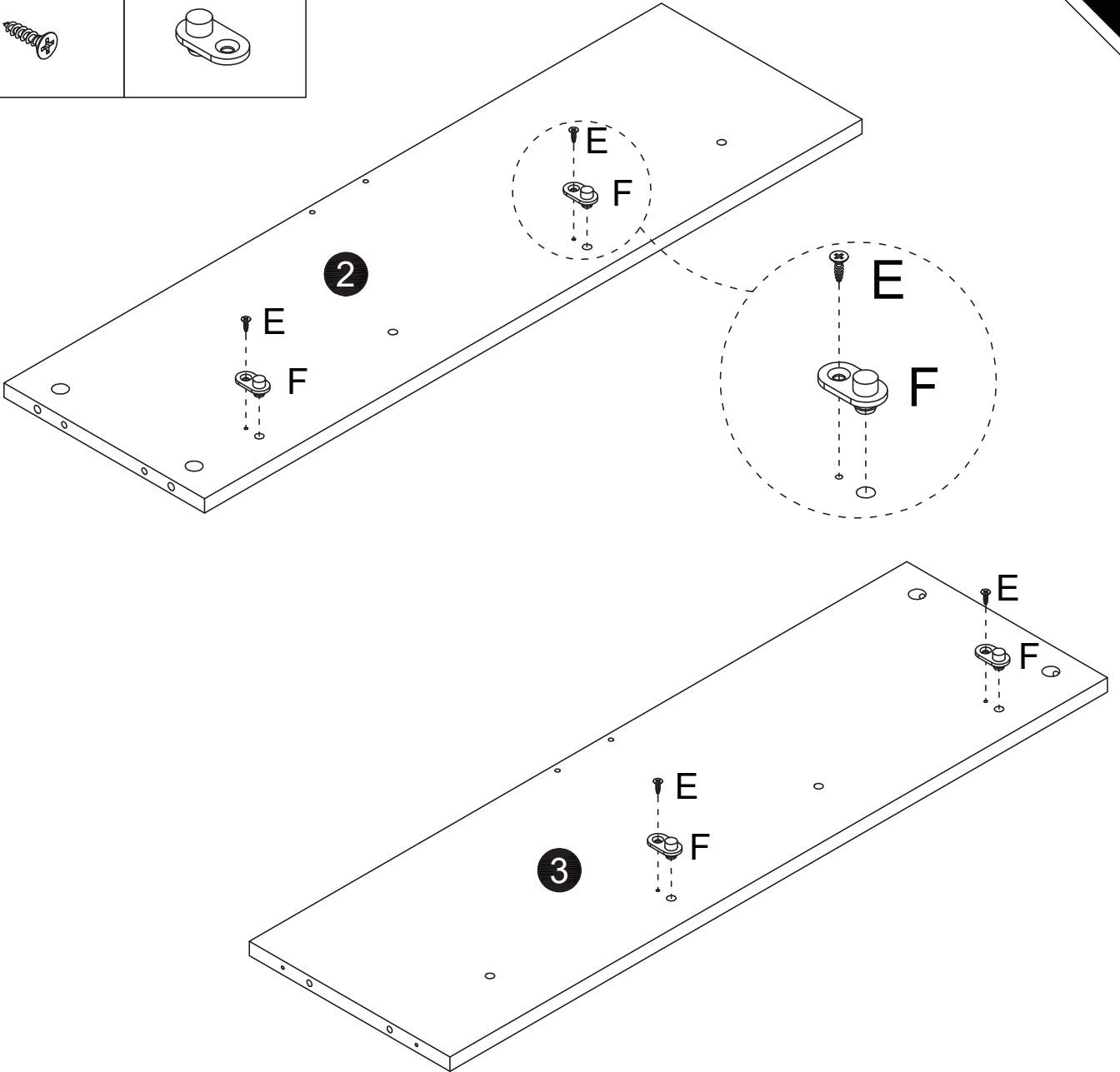

A x8

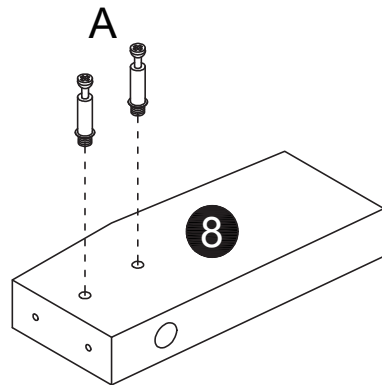
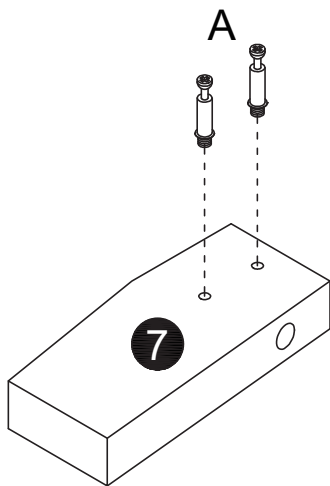
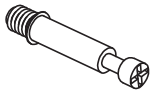

x2

B x8

P x4

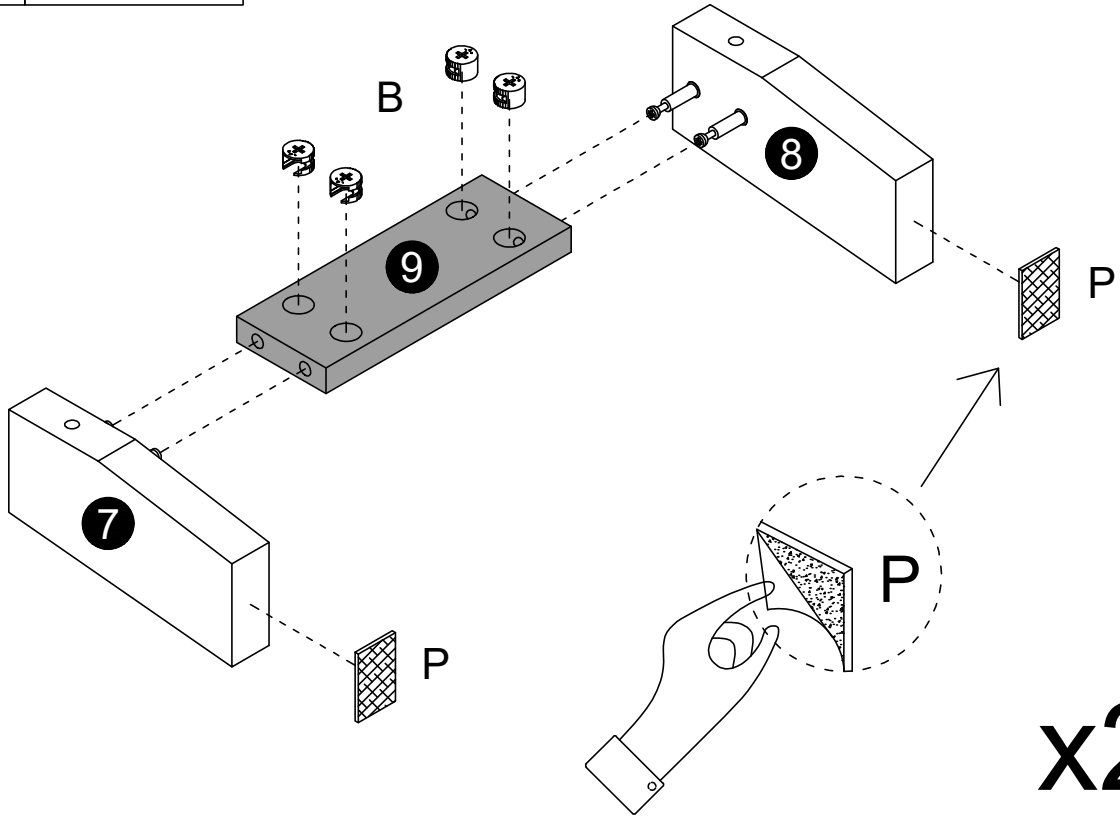
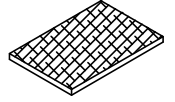

x2

I x4

J x4

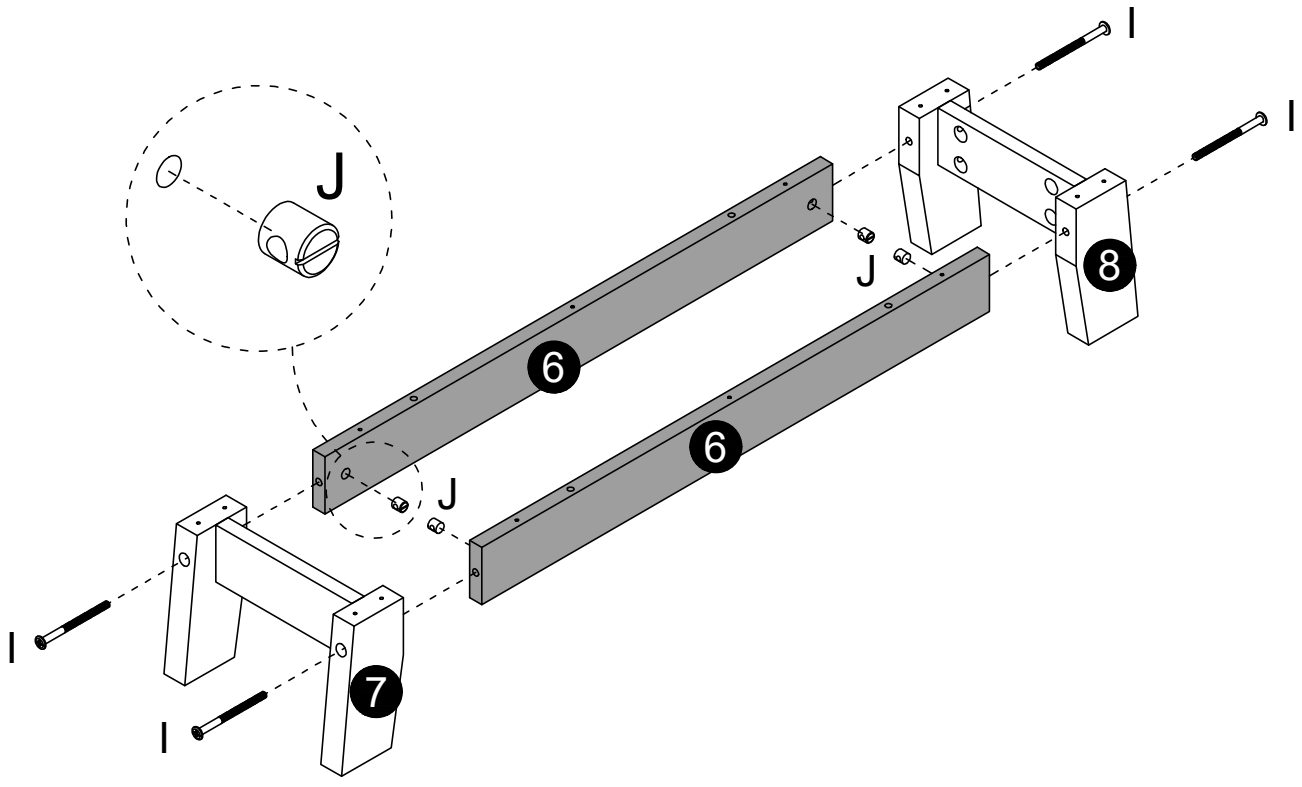
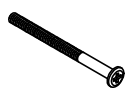

C x4

Q x14

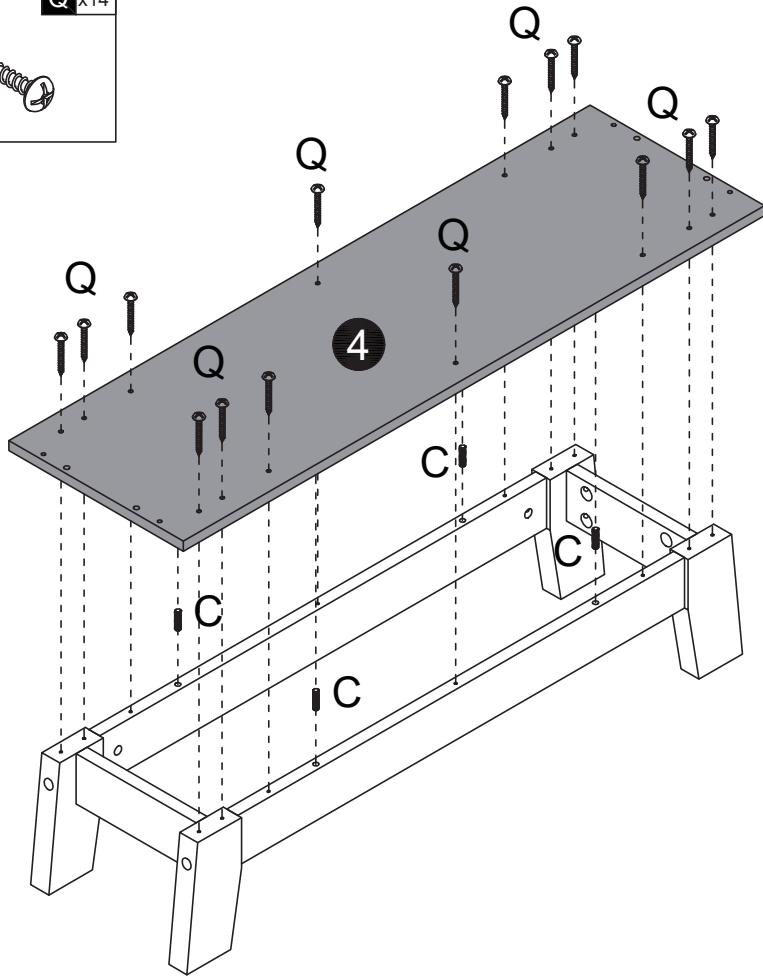
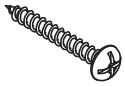

C x4

D x4

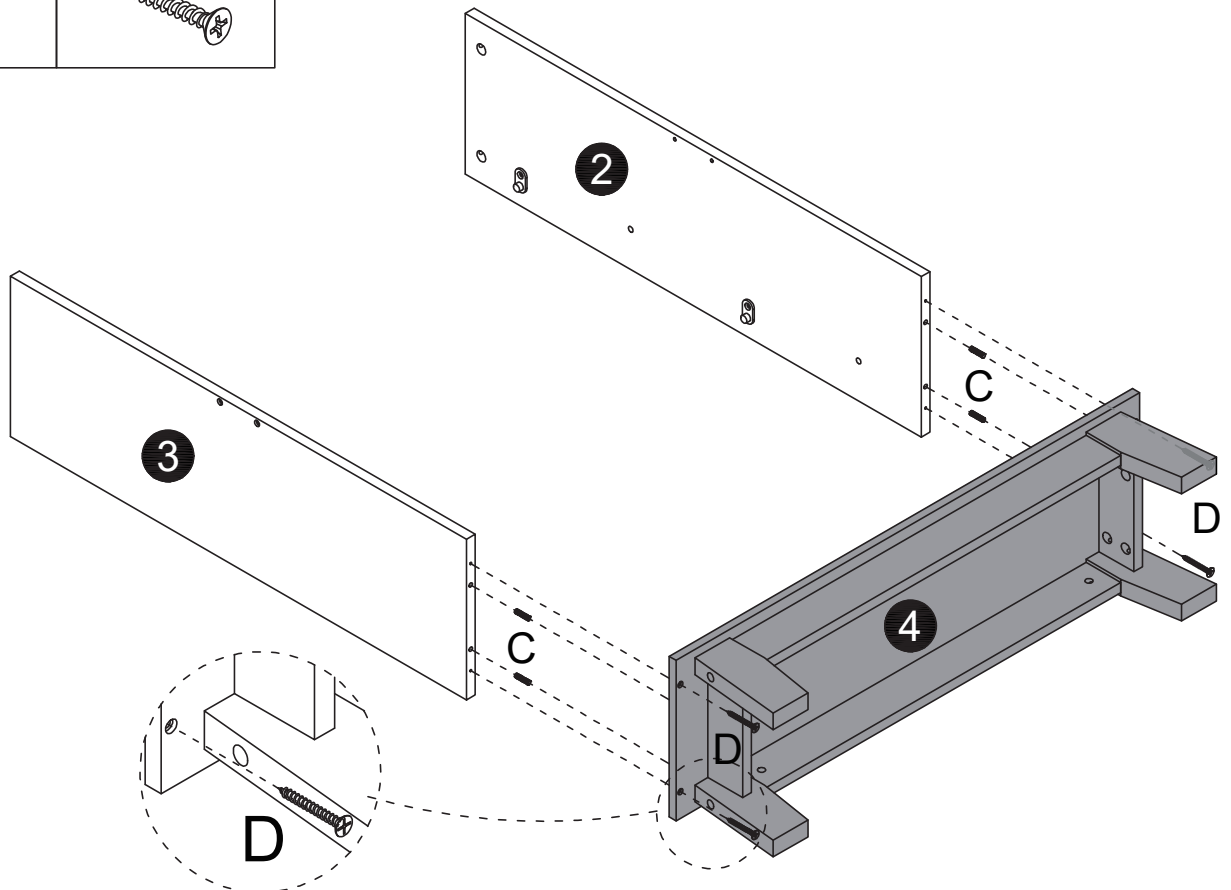

D x4



07

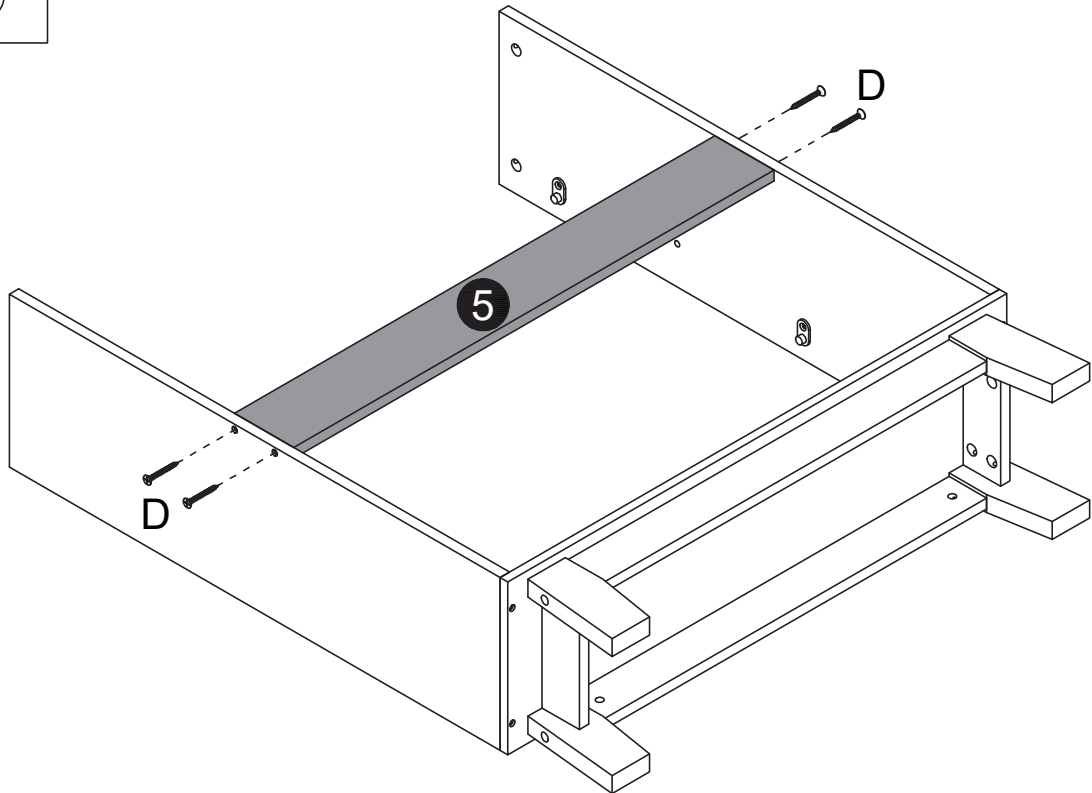

A x4

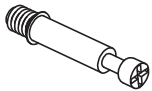

M x2

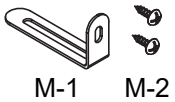

08

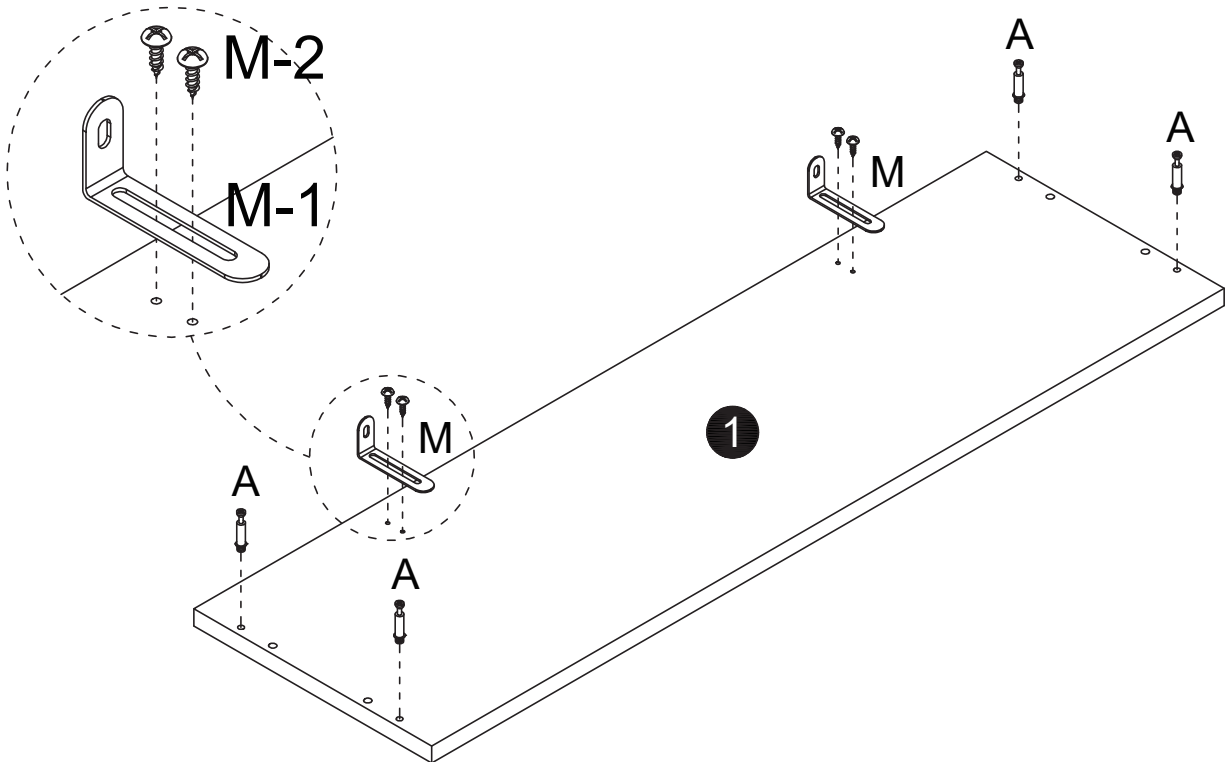

B x4

C x4

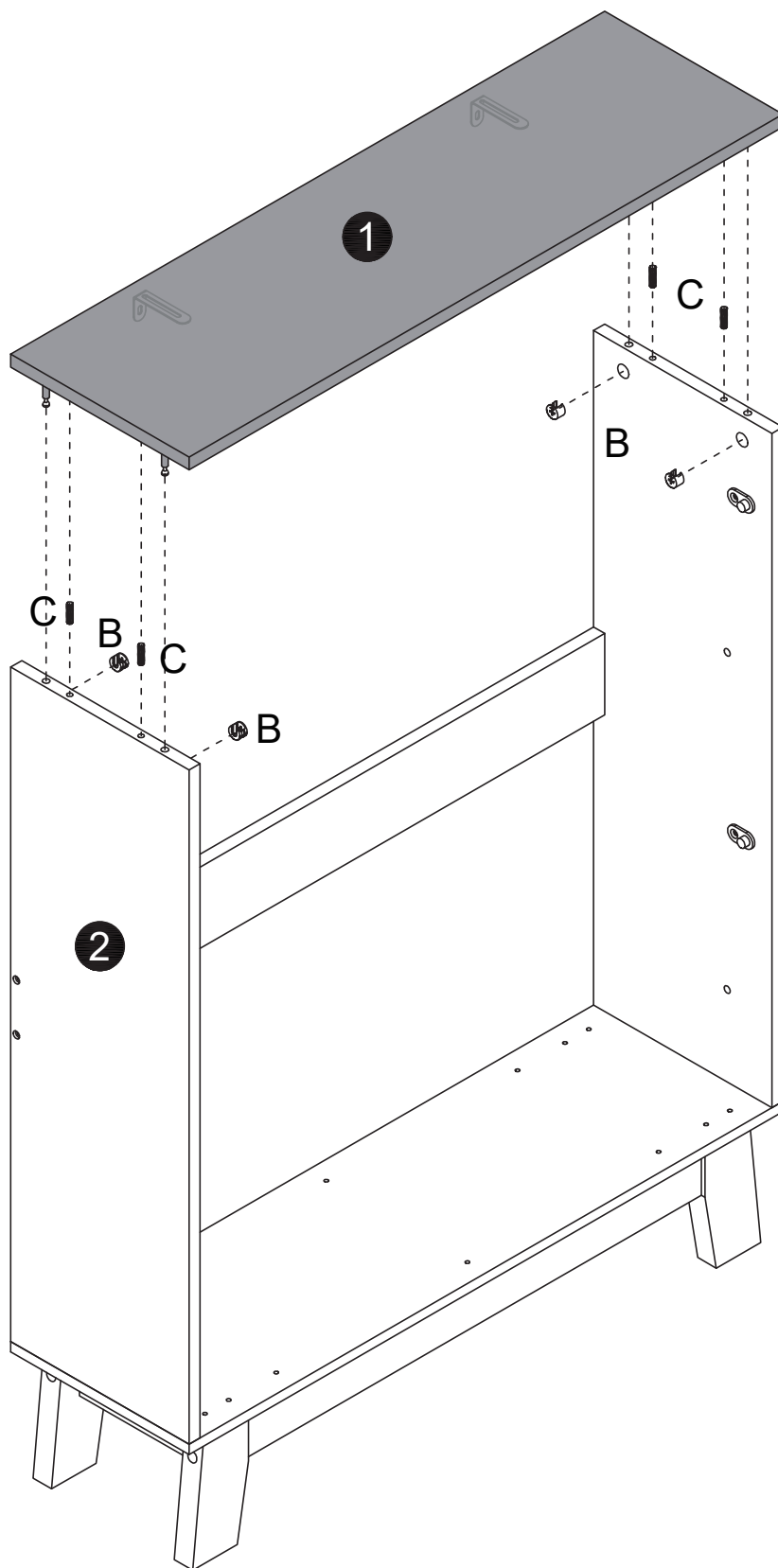

D x2

N x2

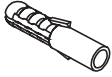
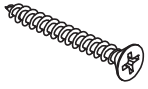

WALL

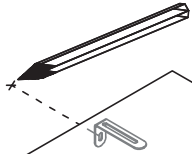

(1)x2

First, use a ruler to measure the approximate height of the product on the wall, and then mark it with a pen.

WALL

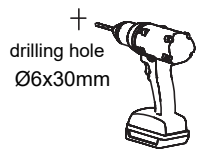

(2)x2

Then use a tape drill to make holes in the wall that are suitable for the product screws.

WALL

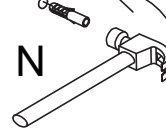

(3)x2

Then, put the expansion bolt into the hole

WALL

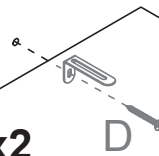

(4)x2

Finally, pass the matching screws through the "anti-rewind" and tighten them to fix them on the wall.

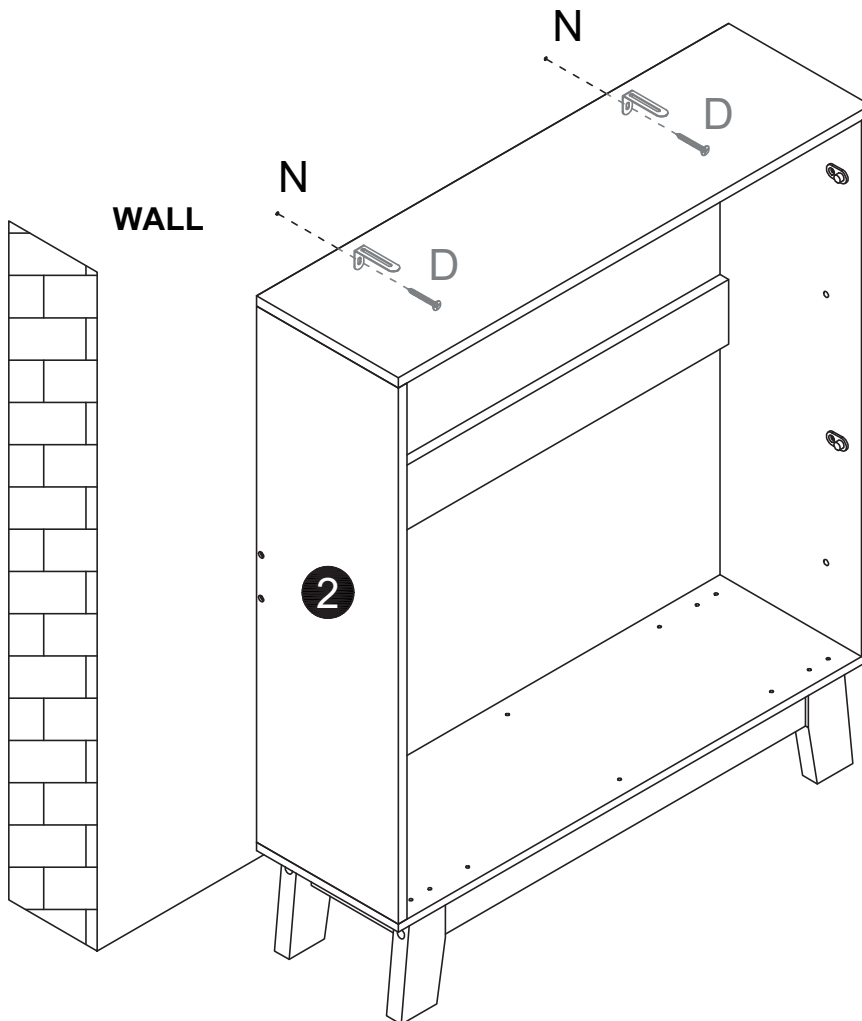

E x24

K x2

L x2

R x2

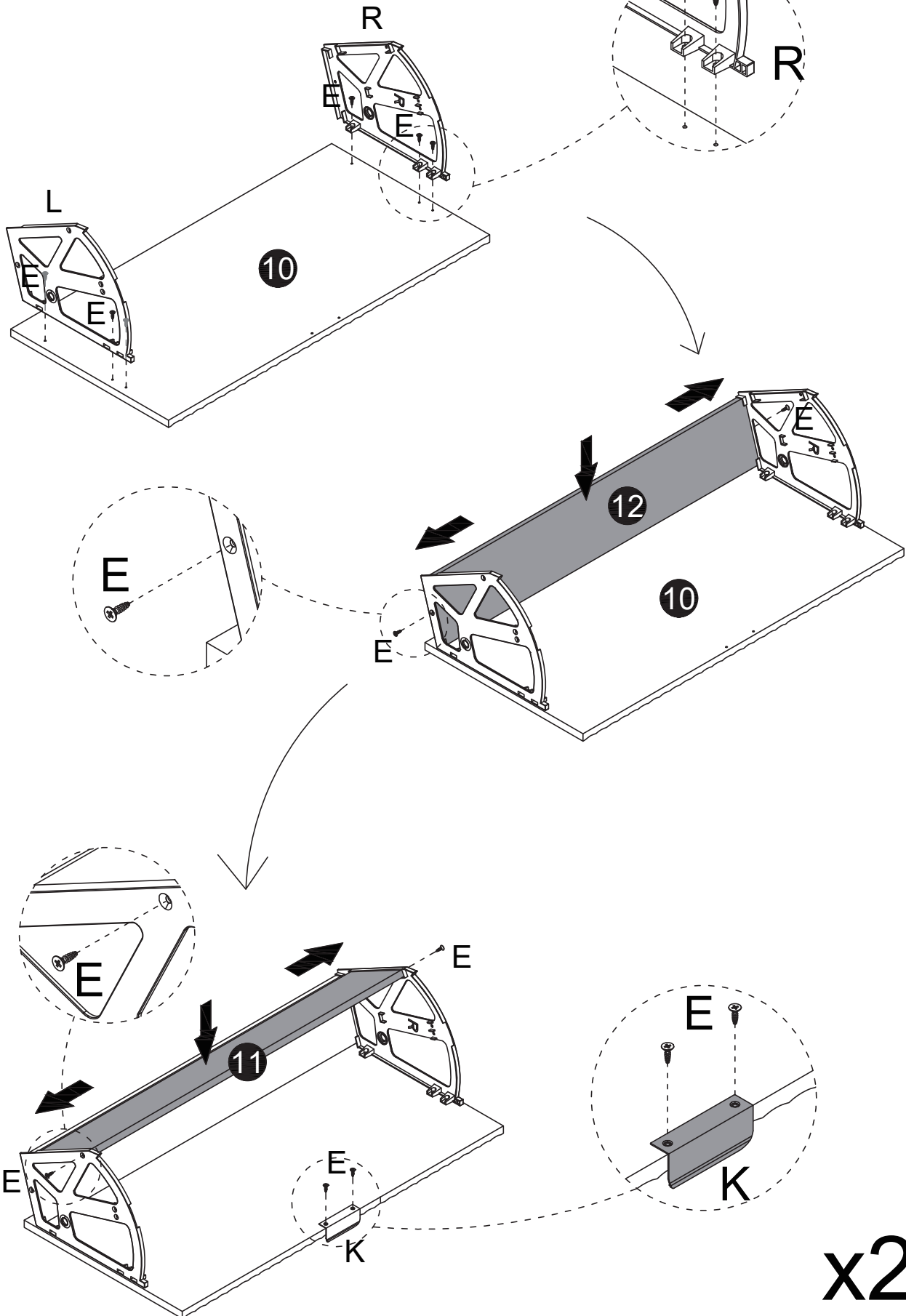
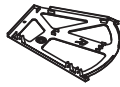

x2

G x4



H x4



S x1

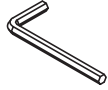

Please do not forcefully lock the installation screws to the maximum limit to avoid damaging the side panel.

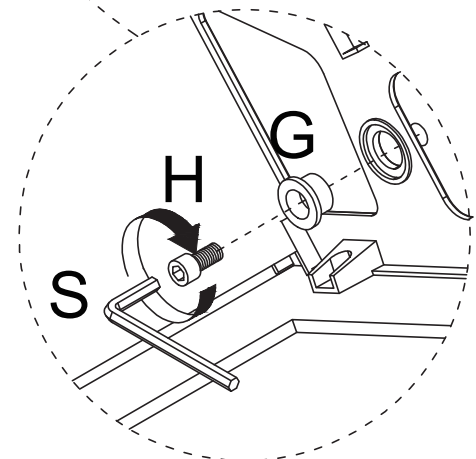
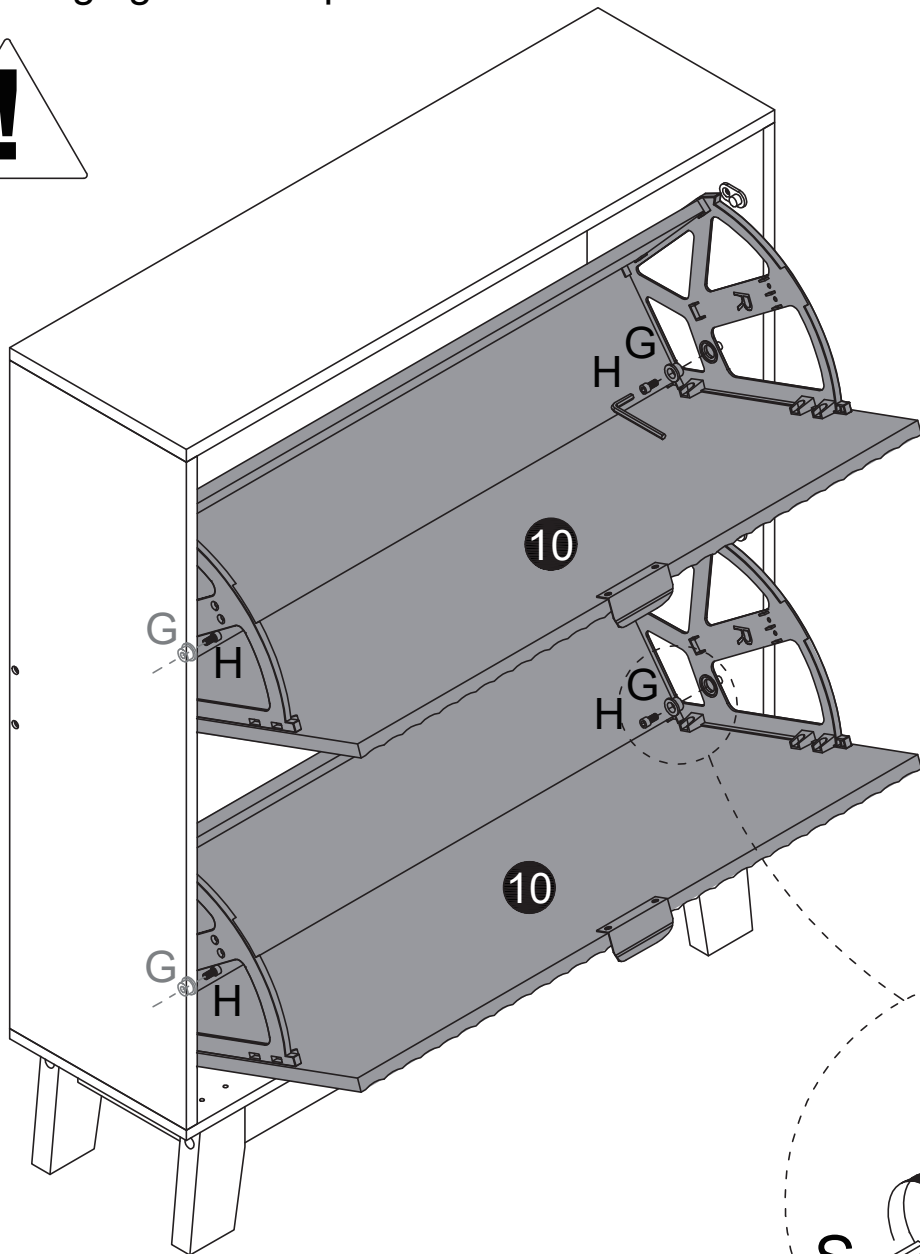
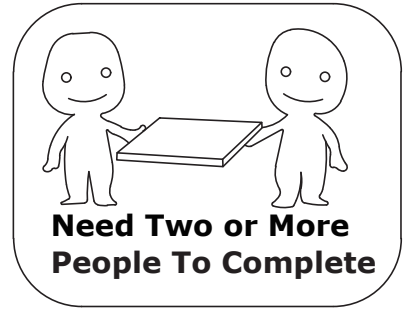

E x4

13

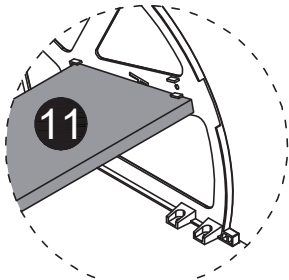

OR

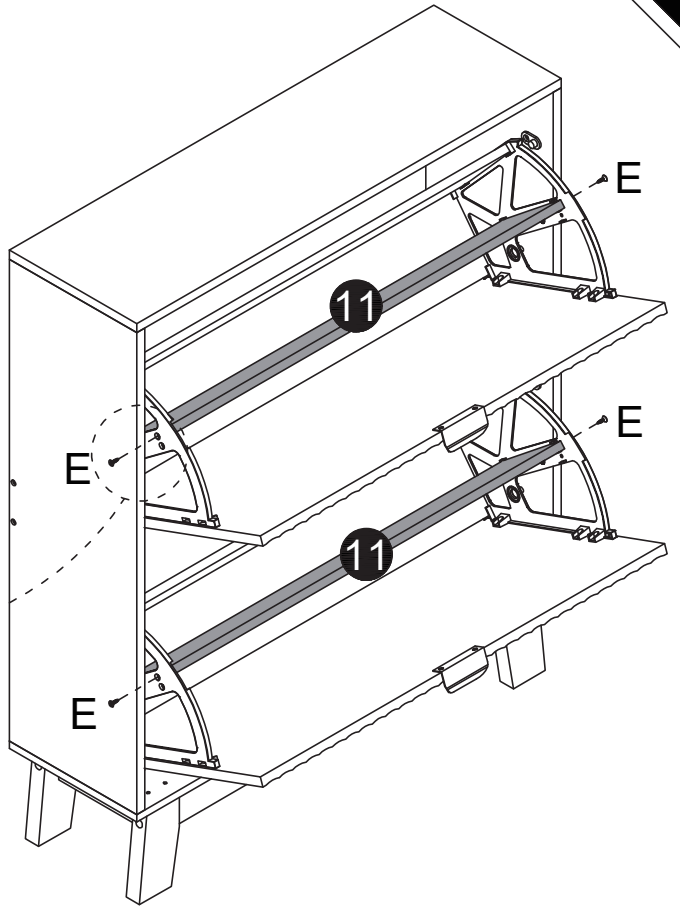
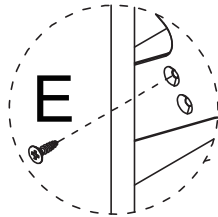
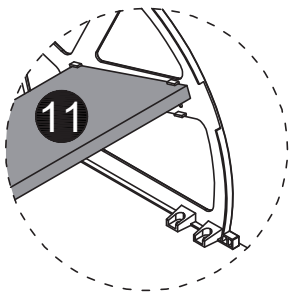

O x8

Done

