

Assembly Instructions

Caution: You must read this before you proceed

Care & Maintenance



- Not for commercial use. For residential use only.



- Furniture may scratch floors. We recommend using furniture pads to protect your floors.



- Do not put hot items directly on furniture surface.



- Do not clean furniture with harsh cleansers or polish.



- Do not place furniture under direct sunlight.



- Do not place furniture near heating or cooling vents.



- Do not write on furniture without a padded barrier to protect the surface.



- Do not place furniture outside . For indoor use only.



- Stains may be removed with mild soap solution and damp cloth.



- Children should not climb or jump on the furniture.



- Dust and pick-up spills using a clean, non-colored, lint-free cloth.

KING BED



WARNING !

STRANGULATION HAZARD

NEVER place bed near windows where cords from blinds or drapes may strangle a child.

NEVER suspend strings over bed.

NEVER place items with a string, cord, or ribbon, such as hood strings or pacifier cords, around a child's neck. These items may catch on bed parts.

ALWAYS follow assembly instructions.

Not intended for children under the age of six. **INFANTS HAVE DIED FROM BECOMING ENTRAPPED IN BEDS.** Openings in and between bed parts can entrap the neck and head of a small child.

NEVER use bed for child under the age of six.

The mattress must be appropriately sized for the bed. If the mattress is undersized, dangerous gaps can exist and a person can become entrapped or entangled in the frame and suffocate.

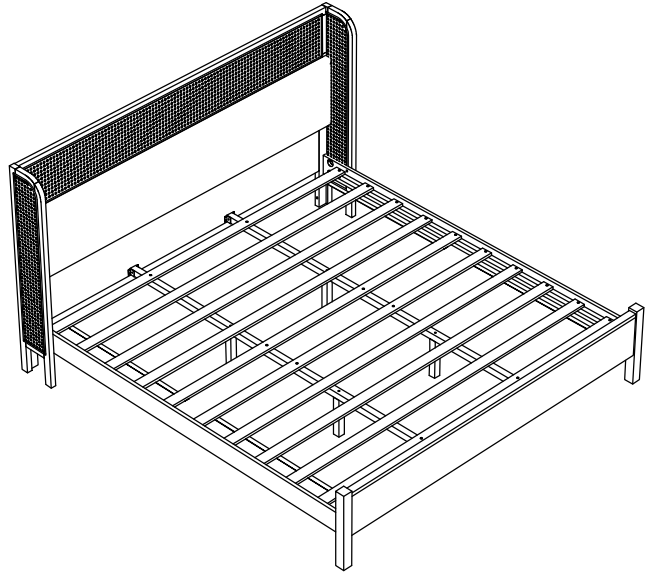









CAUTION: This King Bed is NOT a TOY.

Keep your child / children away in the process of assembly.



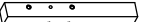
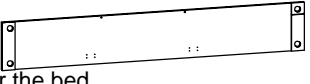

For turning the King Bed and to prevent damage to the King Bed.

02 persons may be needed to execute this action.

PART LIST (N770P375070/Hardware in this SKU)

A		1pc	F		1pc
	Left headboard frame.			Right side panel	
B		1pc	G		2pcs
	Right headboard frame.			Center rail	
C		1pc	H		4pcs
	Left bed foot.			Center support leg	
D		1pc	I		1pc
	Right bed foot.			The frame under the bed	
E		1pc	J		1pc
	Left side panel			Bed frame	

PART LIST (N770P375071)

K		1pc	N		1pc
	Leg-left headboard			The frame between the headboard	
L		1pc	O		2pcs
	Leg-right headboard			Slats	
M		1pc			
	Headboard				

Hardware (Each of the above hardware including extra 1 pc)

Assembly Preparation

Label	Picture	Description	Q.ty
①		Vis Ø 4 x 30mm	28+1
②		Vis Ø 4 x 15mm	24+1
③		Threaded Rod Ø5/16"x70mm)	16+1
④		Bolt Ø1/4" x 55 mm	4+1
⑤		Bolt Ø1/4" x 65mm	4+1
⑥		Bolt Ø1/4" x 45m	6+1
⑦		Bolt Ø1/4" x 35m	2+1
⑧		Bolt Ø1/4" x 30m	2+1
⑨		Screws Ø6.3x80mm	4+1
⑩		Allen wrench	1
⑪		Wooden dowel Ø10 x 40 mm	8+1
⑫		Metal link (66x35x27mm)	4
⑬		Leveler Ø1/4 x 25 mm	4
⑭		Hex nut (M8x6mm)	16+1
⑮		Half moon washer (27x4x7mm)	16+1
⑯		Open wrench (90x12mm)	1
⑰		Screwdriver (Not provided)	1

Before Beginning Assembly

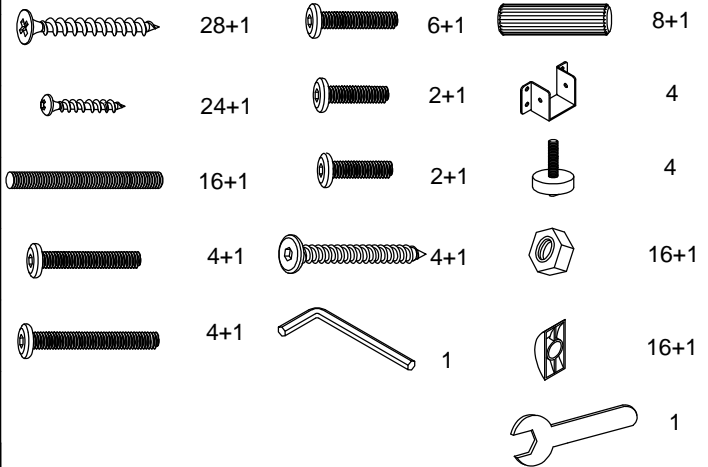
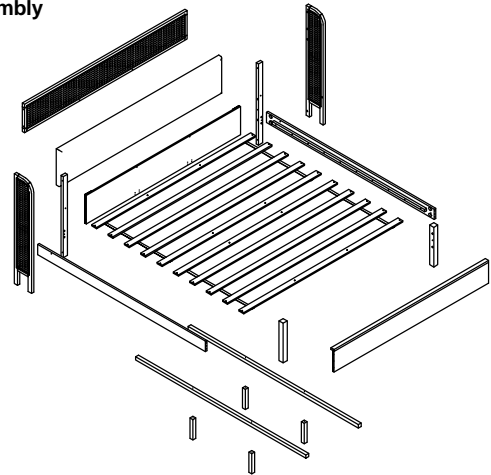

- Read instruction, cover to cover.
- Have 2 adults on hand for assembly.
- Do not assemble on flooring or carpet.
- Assemble on a clean non-marring surface (packing foam).
- Save all packaging until finished.

Assembly Preparation

Overview

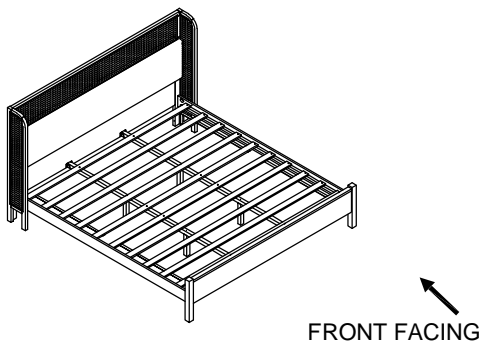

This King Bed has multiple parts and may require up to 1 hour to assemble. To give you an overview of the King Bed parts, the above picture is to help you put the various parts into perspective. Please read through the instructions herebelow to familiarise the parts and steps before assembly.

Step 1:

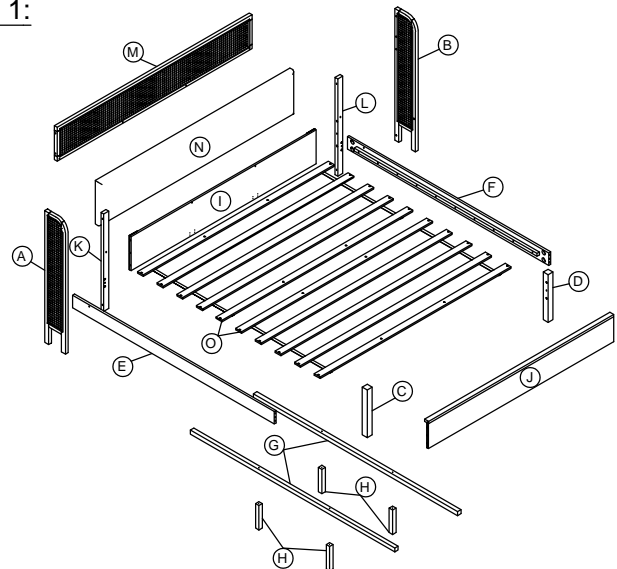

Unpack and place all part on a clean, non-marring surface.

Step 2:

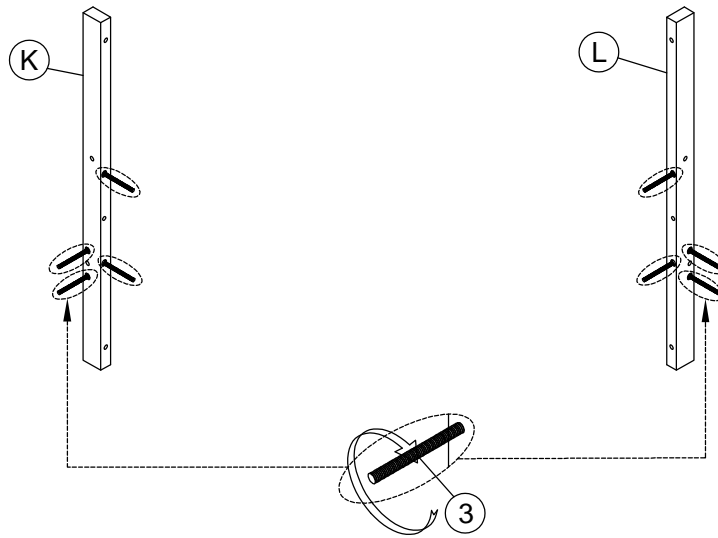

- Attach the Threaded Rod (3) to the Leg-left headboard(K) and Leg-right headboard(L) as shown in the illustration.
Do not fully tighten the Bolts.

Step 3:

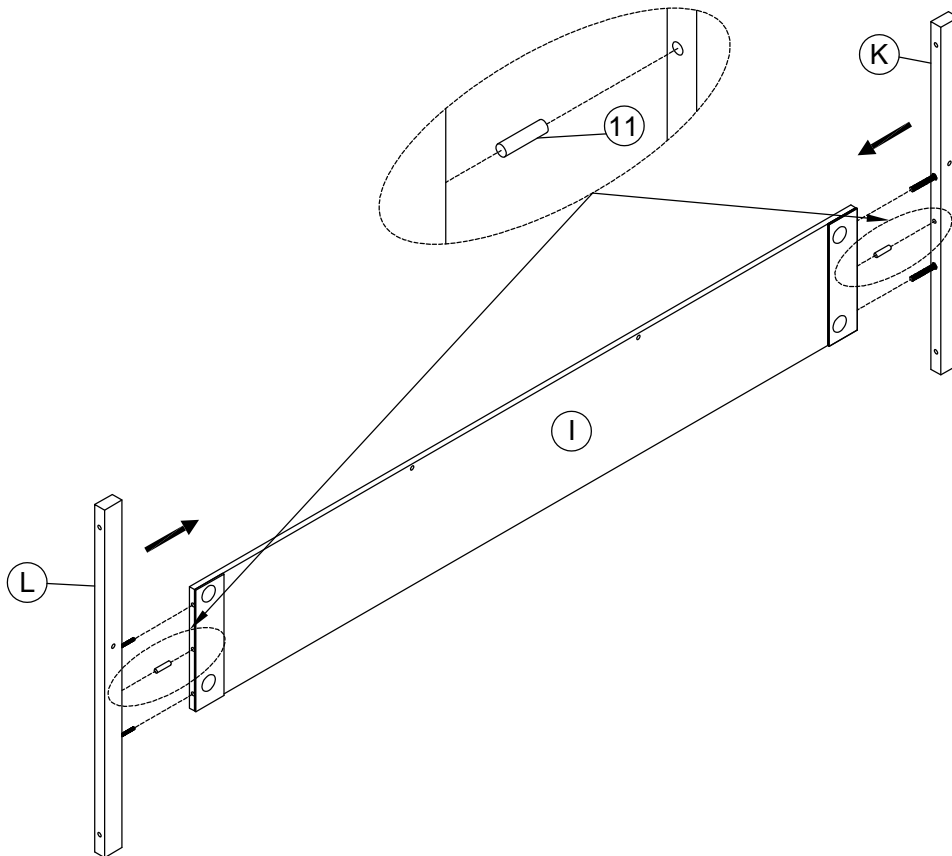

Assemble The frame under the bed (I) to the Leg-left headboard (K) and Leg-right headboard (L) using wooden dowel (11) as shown in the picture.
- Do not fully tighten the Bolts.

Step 4:

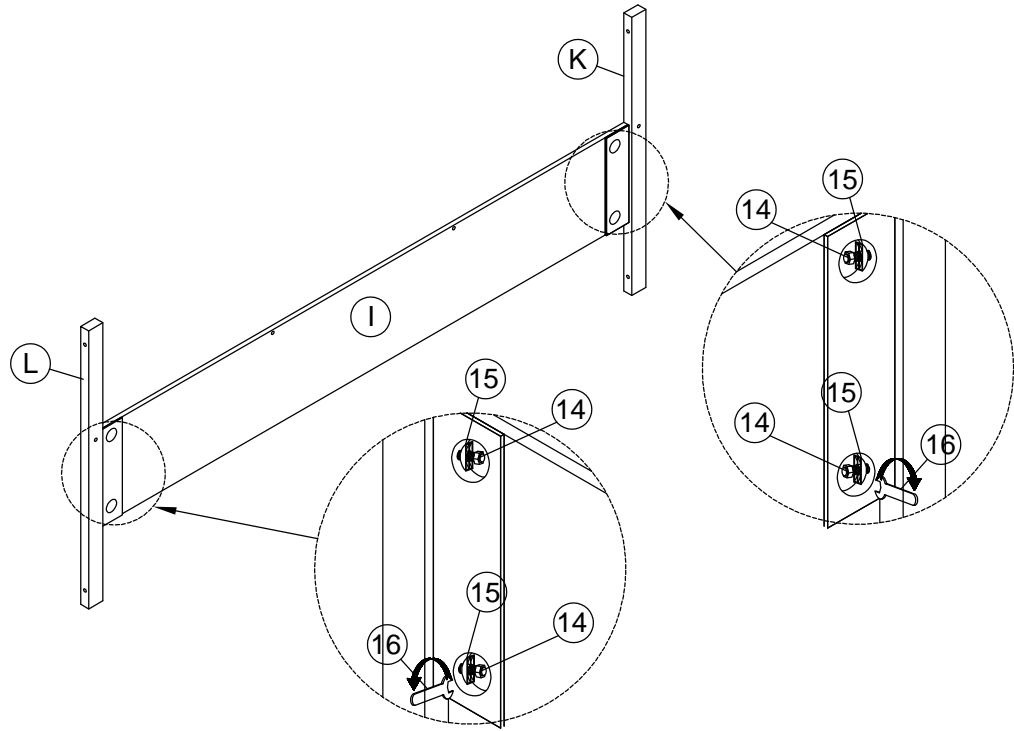

-After completing step 3, we connect the assembly using Hex nut (14), Half moon washer (15), and Open wrench (16) as shown in the image.
Do not fully tighten the Bolts.

Step 5:

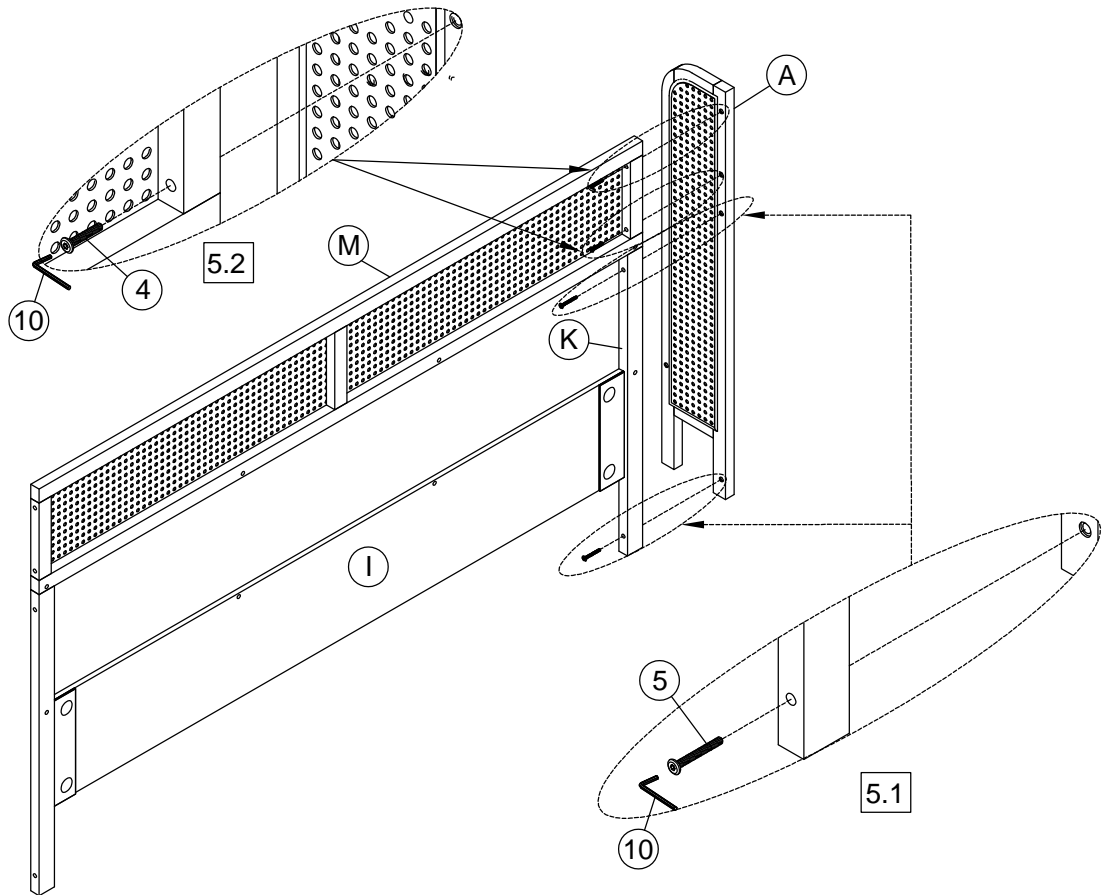

- Assemble the assembly in step 4, Headboard (M) to the Left headboard frame (A).
5.1: Assemble the assembly from step 4 to the Left headboard frame (A) using Bolt (5) and Allen wrench (10) as shown.
5.2: Attach the Headboard (M) to the Left headboard frame (A) using Bolt (4) and Allen wrench (10) as shown.
Do not fully tighten the Bolts.

Step 6:

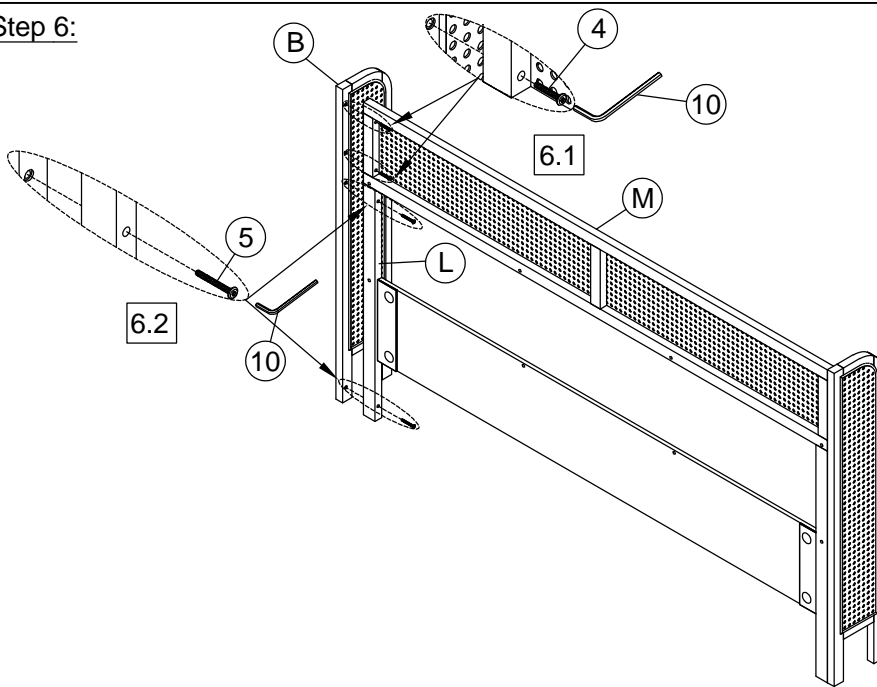

-Assemble the assembly in step 5 to the Right headboard frame (B).

6.1: Attach the Headboard (M) to the Right headboard frame (B) using Bolt 4 and Allen wrench 10 as shown

6.2: Attach the Leg-right headboard (L) to the Right headboard frame (B) using Bolt 5 and Allen wrench 10 as shown.

Do not fully tighten the Bolts.

Step 7:

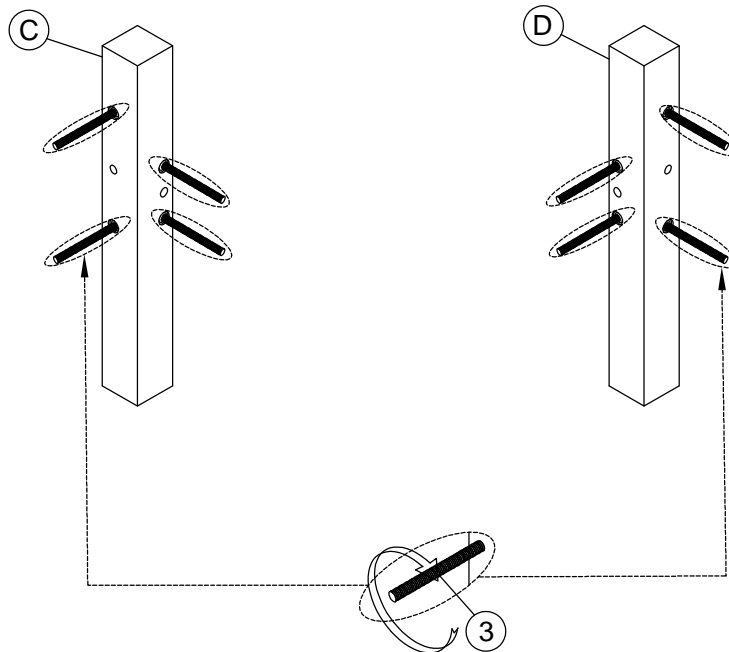

- Attach the Threaded Rod 3 to the Left bed foot(C) and Right bed foot(D) as shown in the illustration.

Do not fully tighten the Bolts.

Step 8:

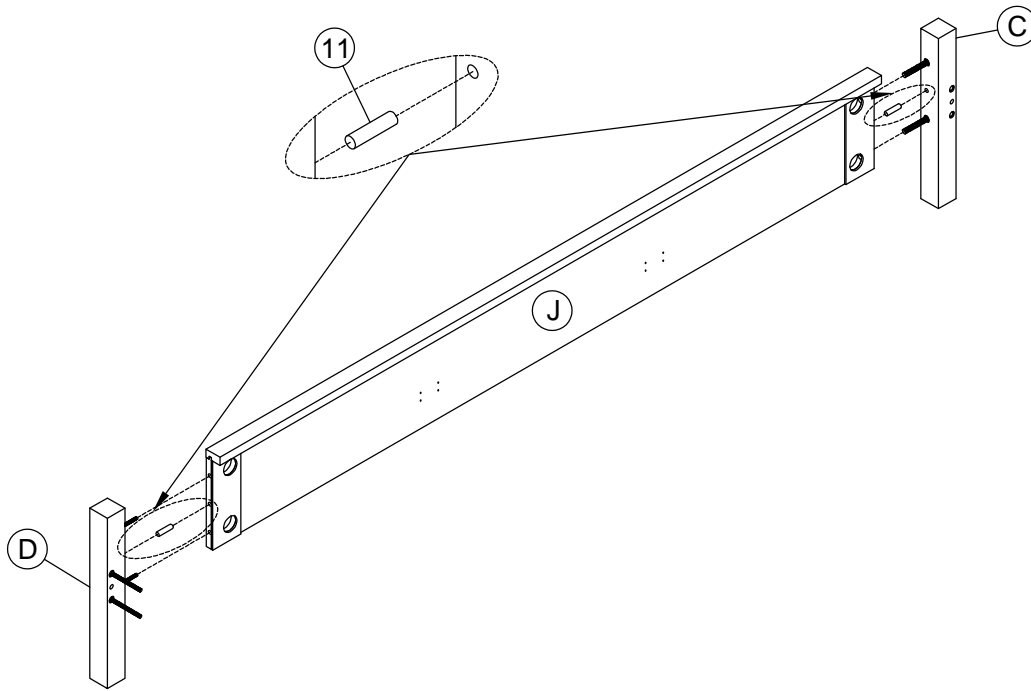

-Assemble the Bed frame (J) to the Left bed foot (C) and Right bed foot (D) using Wooden dowel (11) as shown in the picture.

Do not fully tighten the Bolts.

Step 9:

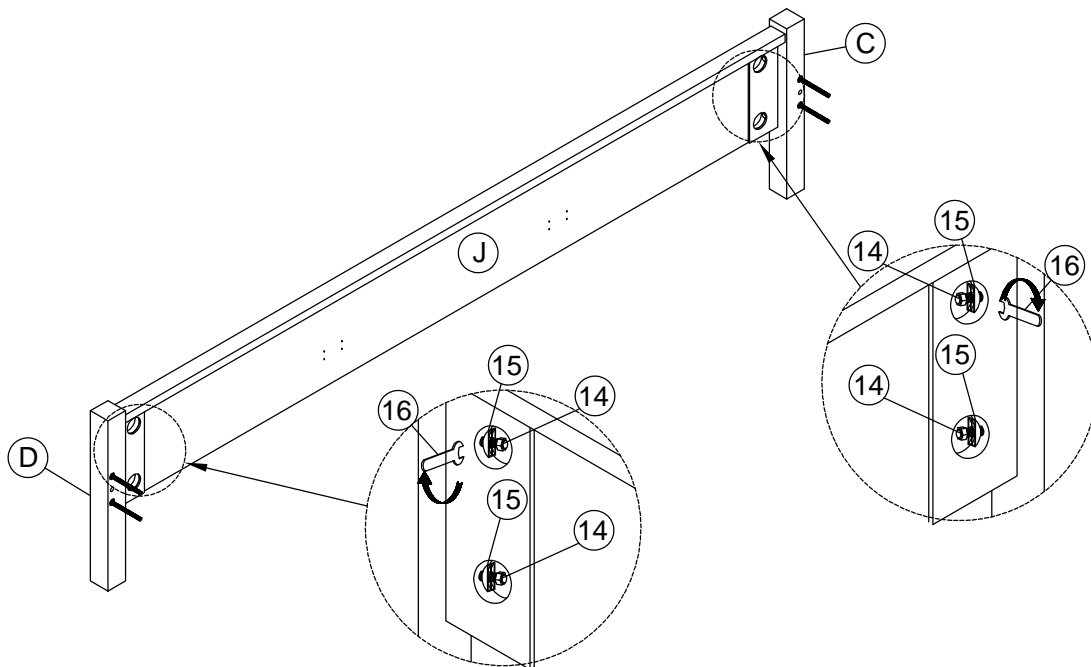

- Next, in step 8, we connect using a Hex nut (14), Half moon washer (15), and Open wrench (16) as shown in the image.

Do not fully tighten the Bolts.

Step 10:

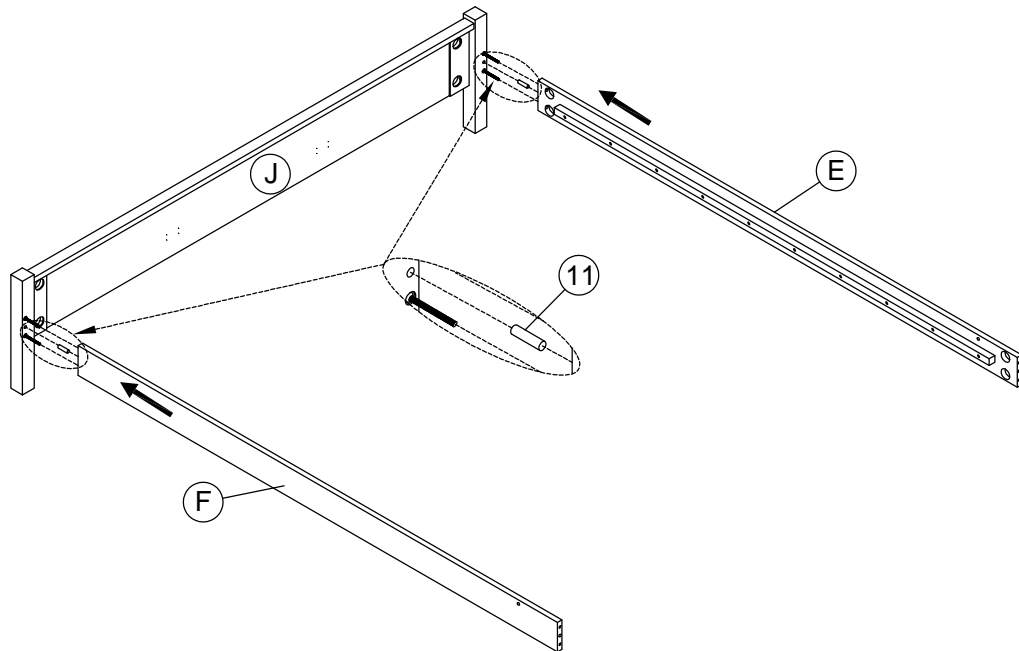

-Assemble the Left side panel (E) and the Right side panel (F) into the assembly completed in step 9 using wooden dowel (11) as shown in the picture.
Do not fully tighten the Bolts.

Step 11:

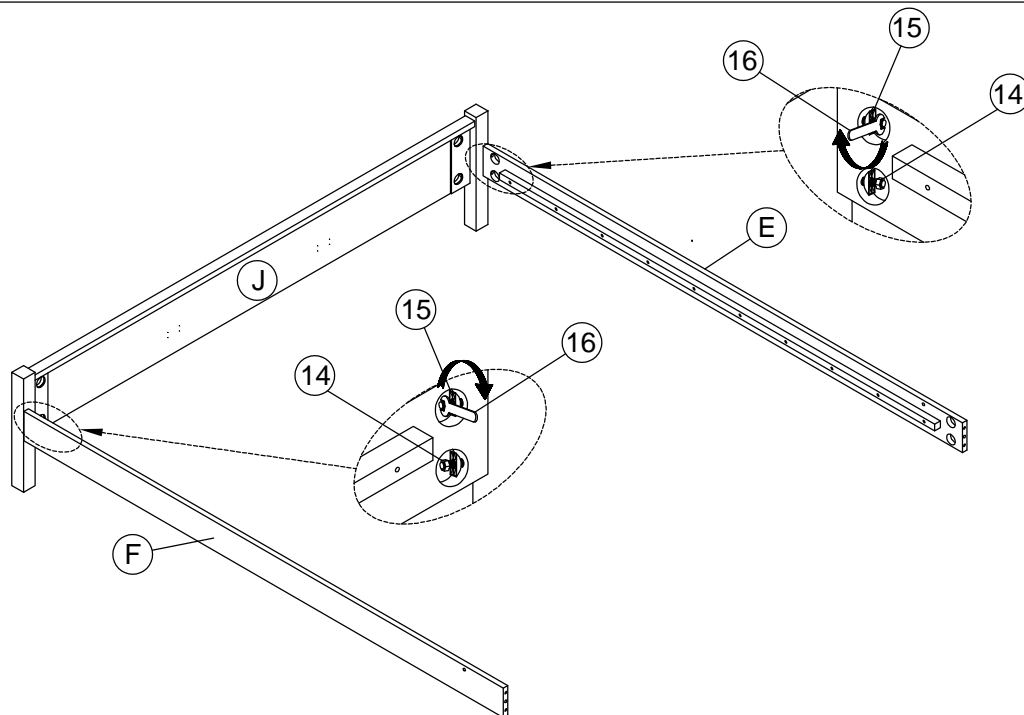

- After step 10, we connect using a Hex nut (14), Half moon washer (15), and Open wrench (16) as shown in the image.
Do not fully tighten the Bolts.

Step 12:

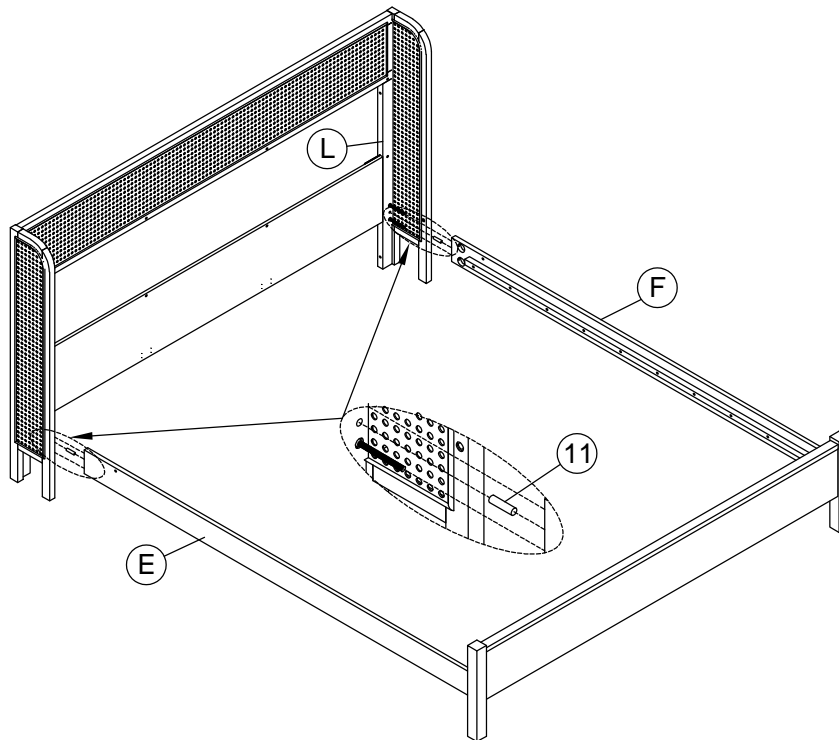

- Assemble the unit that was assembled in steps 6 and 11 using Wooden dowel (11) as shown in the picture.
Do not fully tighten the Bolts.

Step 13:

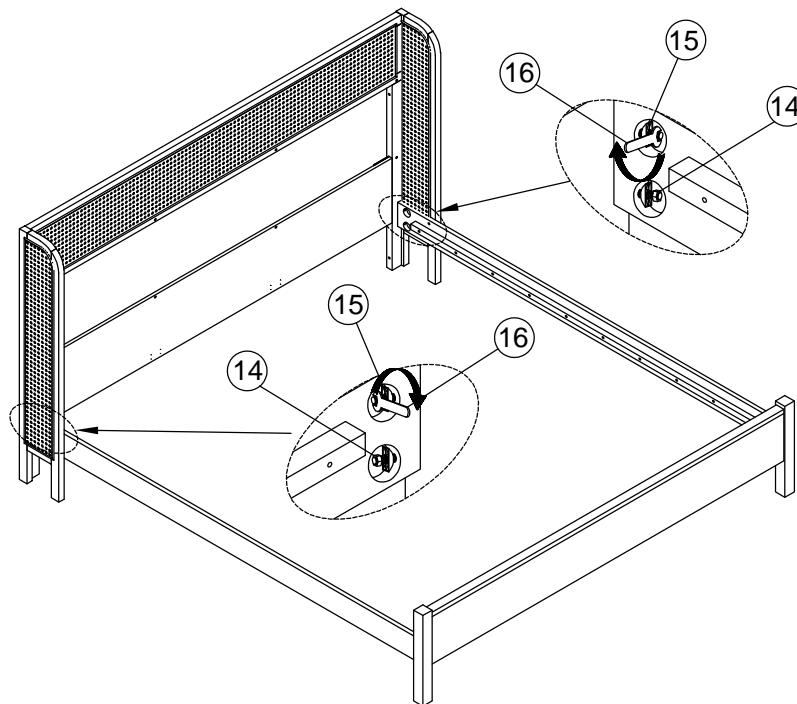

- After completing step 12, we connect using Hex nut (14) , Half moon washer (15) , and Open wrench (16) as shown in the image.
Do not fully tighten the Bolts.

Step 14:

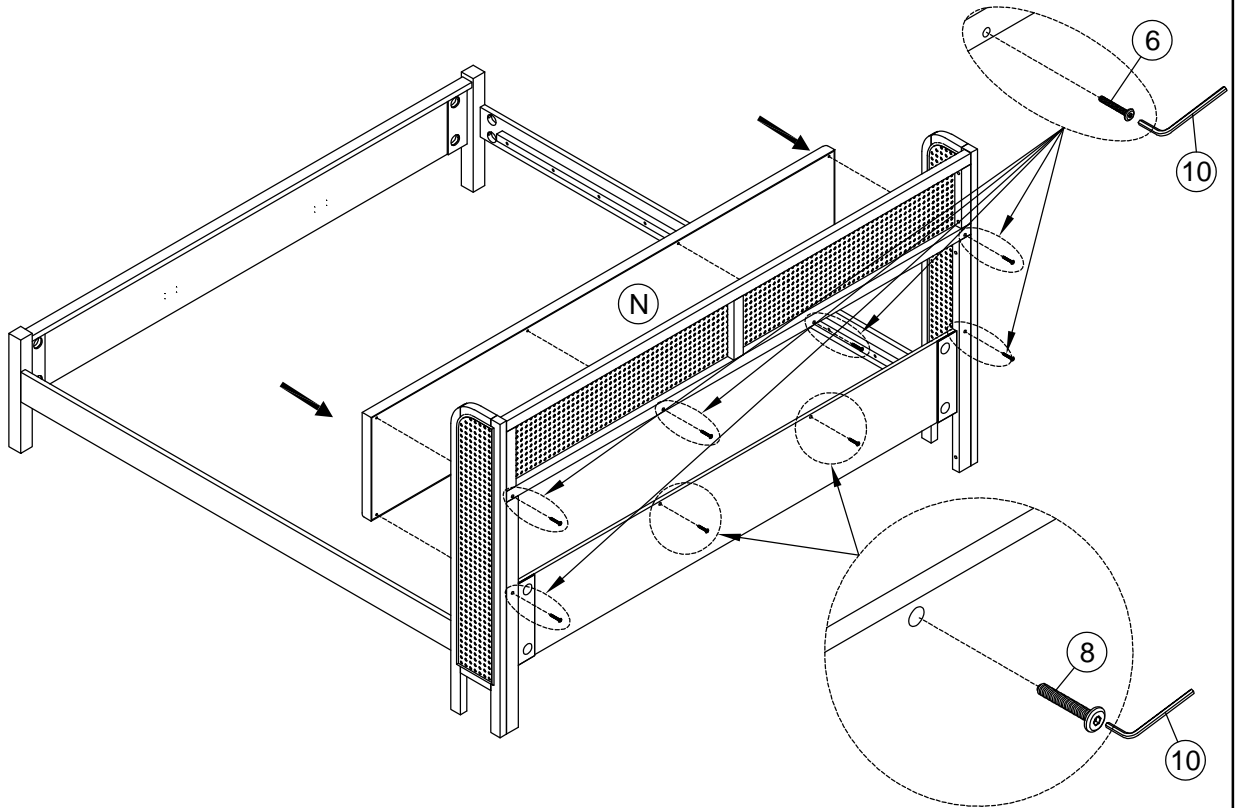

Assemble the frame between the Headboard (N) into the bed frame using Bolt (6), Bolt (8), and Allen wrench (10) as shown in the image.

Do not fully tighten the Bolts.

Step 15:

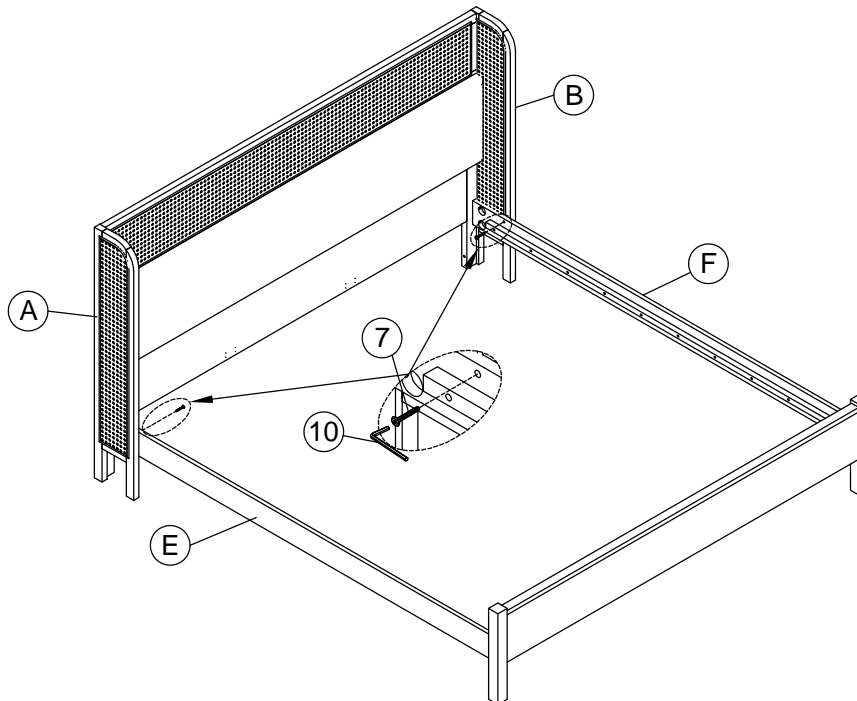

- Assemble the Left side panel (E) with the Left headboard frame (A), and the Right side panel (F) with the Right headboard frame (B) using Bolt (7) and Allen wrench (10) as shown in the image.

Do not fully tighten the Bolts.

Step 16:

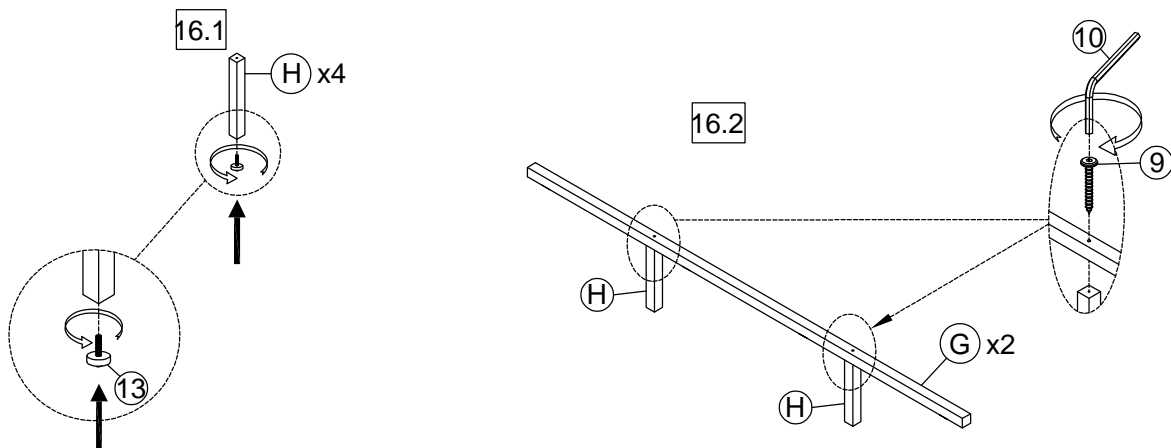

16.1: Attach Leveler (13) to Center support leg (H) as shown in the image.

16.2: After step 16.1, attach the Center support leg (H) to the Center rail (G) using Screws (9) and the Allen wrench (10) as shown in the image.

Do not fully tighten the Bolts.

Step 17:

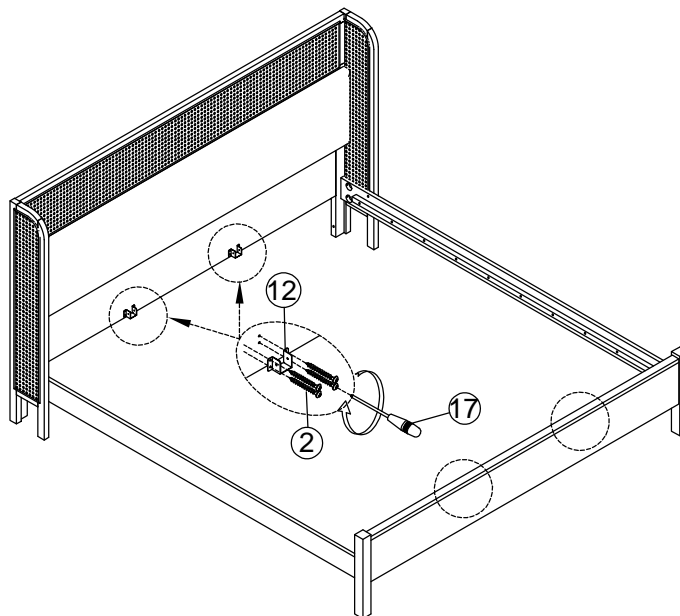

-Attach the Metal link (12) to the Headboard using Vis Ø4x15mm (2) and Screwdriver (17) through the drilled hole positions as shown in the image.

Do not fully tighten the Bolts.

Step 18:

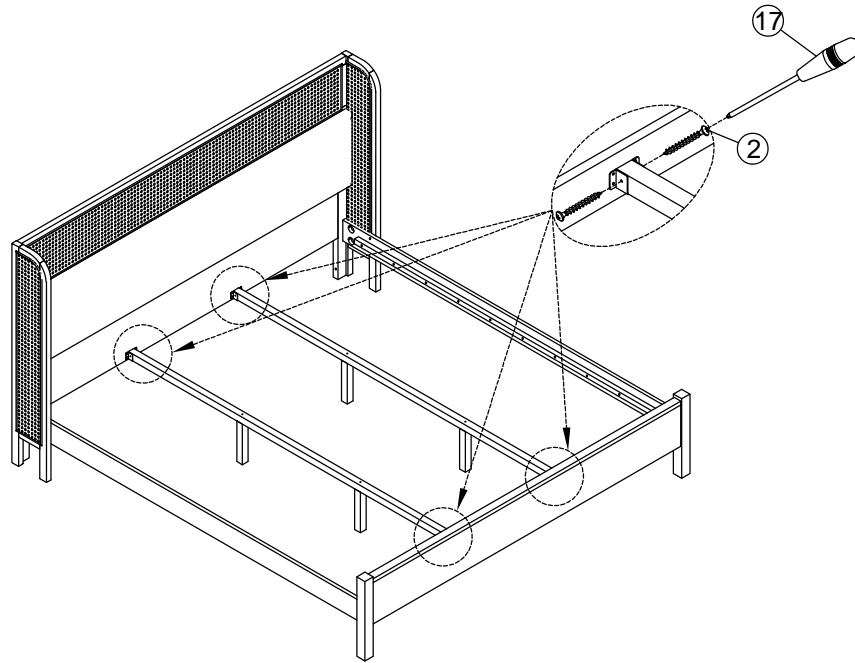

-Attach the assembly completed in step 16 to the Metal link (12) using Vis Ø4x15mm (2) and Screwdriver (17) as shown in the image.

Do not fully tighten the Bolts.

Step 19:

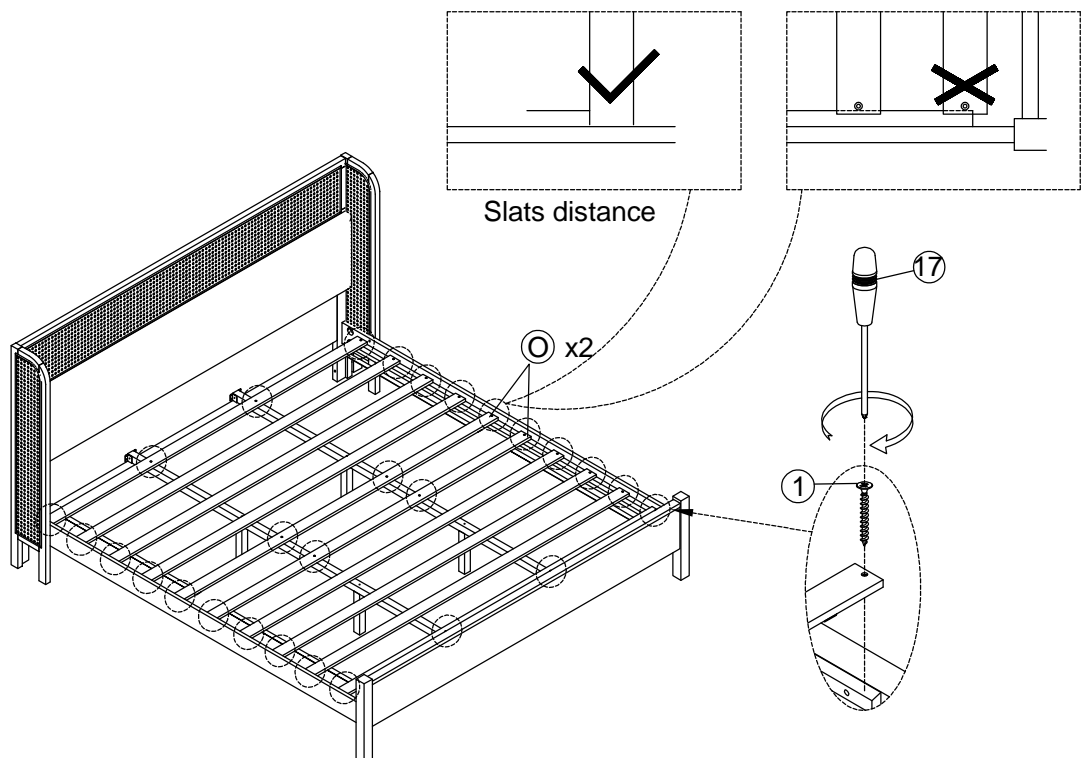

-Attach the Slats (O) to the bed frame as shown using Vis Ø4x30mm (1) and Screwdriver (17) as illustrated.
TIGHTEN ALL HARDWARE 100%

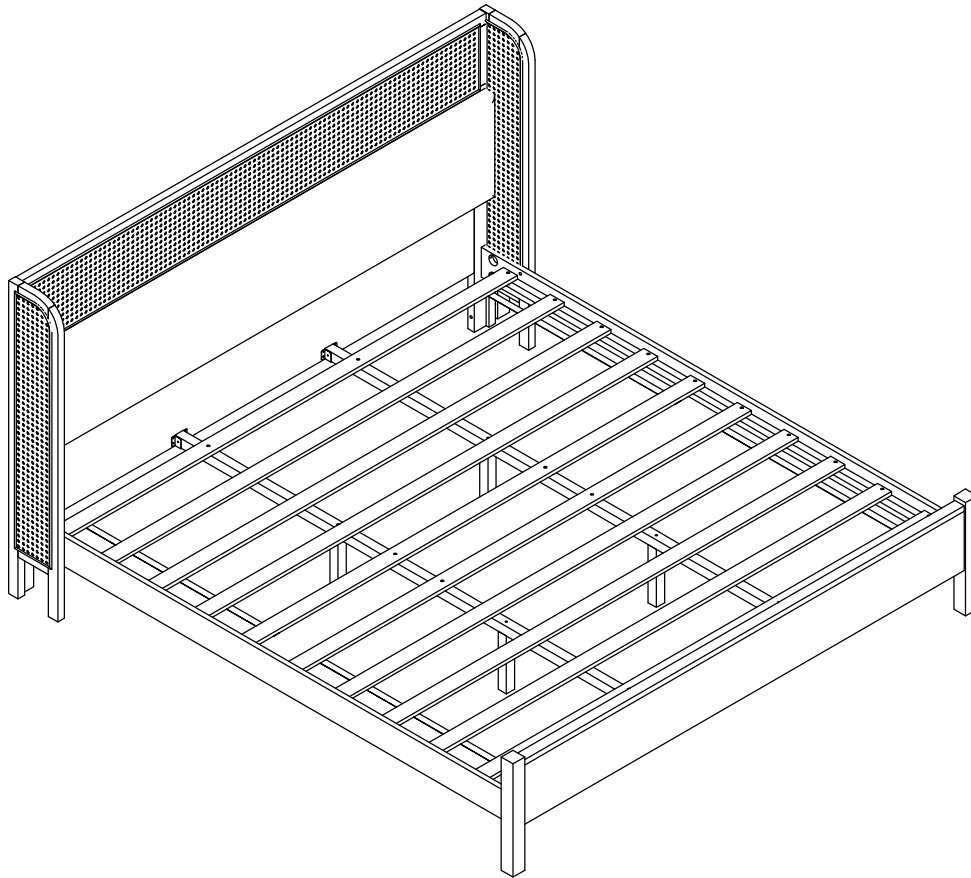

**Inspect the Bed and make sure all parts are adequately connected.
Adjust the Levelers to desired height to avoid wobbles.
Your bed is ready for use.**

CARE INSTRUCTIONS:

**Hardware may loosen overtime. Periodically check that all connections are tight.
Wipe with a soft, dry cloth. To protect finish, avoid the use of chemicals and household cleaners.**