

Assembly Instructions

BENCH

Caution: You must read this before you proceed

Please look underneath the Bench Top for hardware packs.

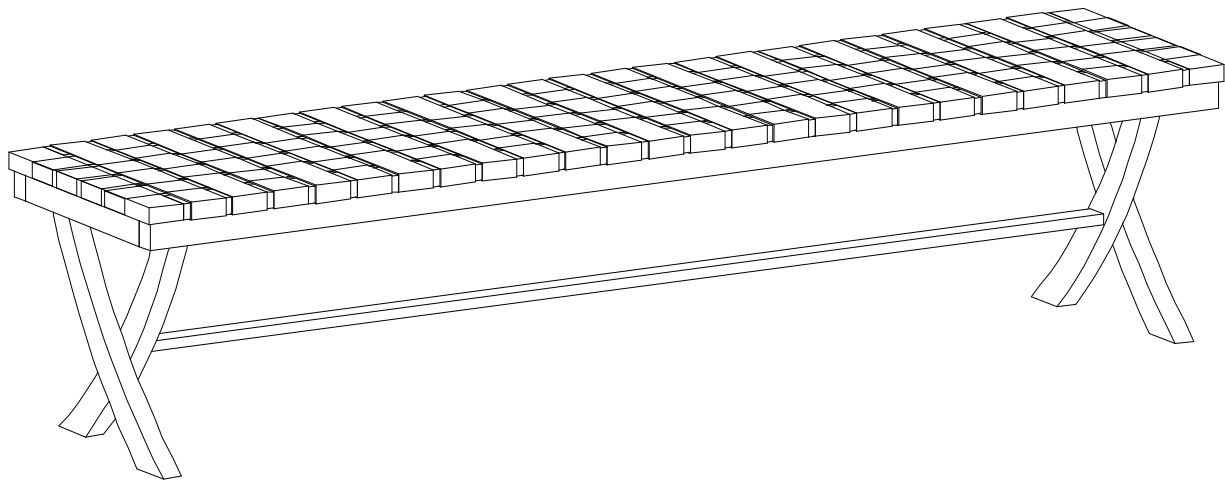



Caution: This Bench is NOT a TOY



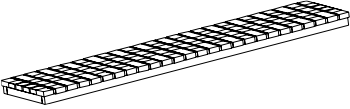

Keep your child/children at bay during the assembly process.

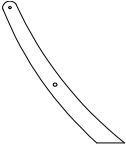
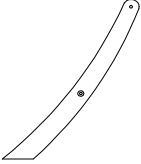
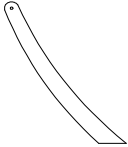
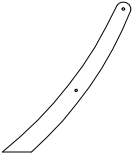
Whenever moving/lifting the Bench and to prevent damage to the Bench, two adults are needed to execute these actions.

Part List

Label	Picture	Description	QTY
A		Bench Top	1
B		Support Bar	1
C		First Leg	1
D		Second Leg	1
E		Third Leg	1
F		Fourth Leg	1

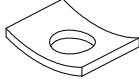
Hardware

Label	Picture	Description	QTY
①		Bolt (M8x45mm)	5
②		Bolt (M8x70mm)	3
③		Plastic Washer (M8.5/20x2)	3
④		Crescent Washer (M9/22.5x1.8)	3
⑤		Spring Washer (M8.5/12x1.5)	3
⑥		Allen Key	2

Assembly Preparation

Before Beginning Assembly:

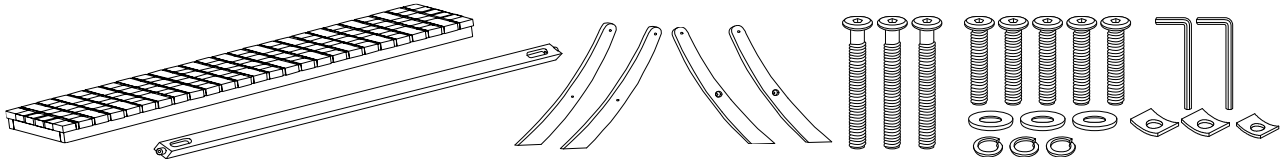

- Read instructions, cover to cover-



- Have 2 adults on hand for assembly-



- Do not assemble on flooring or carpet-



- Assemble on a clean non-marring surface (packing foam)-



- Save all packaging until finished-

Assembly Steps

Overview

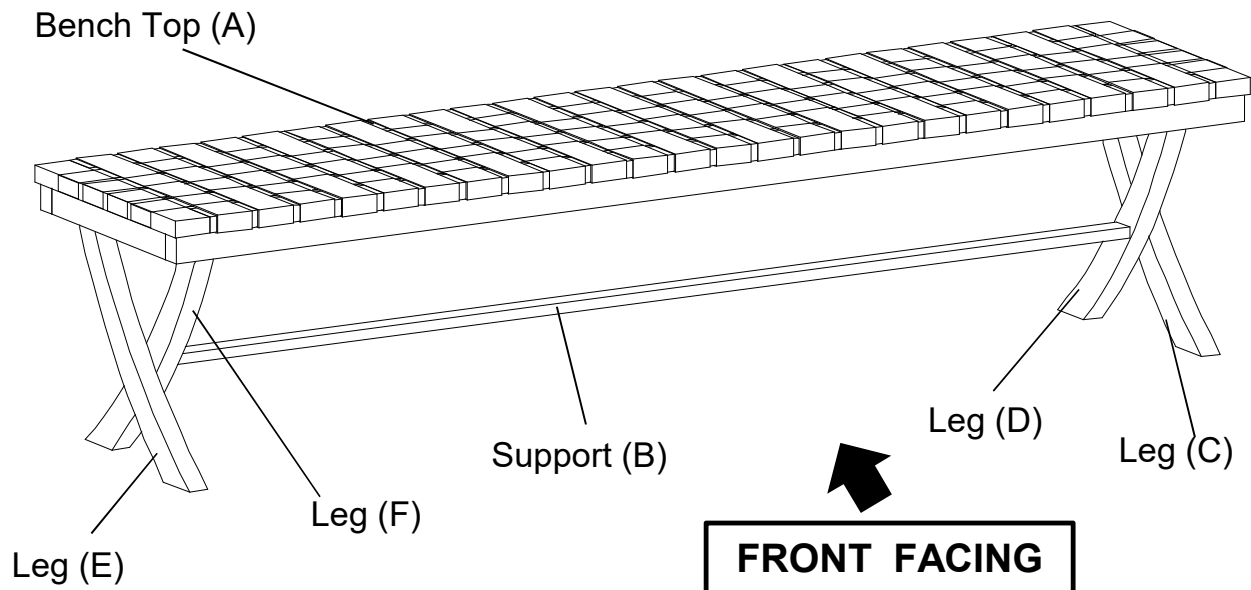

This Bench has multiple parts and may require up to 30 minutes to assemble. To give you an overview of the Bench parts, the above picture is to help you put the various parts into perspective. Please read through the instructions below to familiarise yourself with the parts and steps before assembly.

Step 1

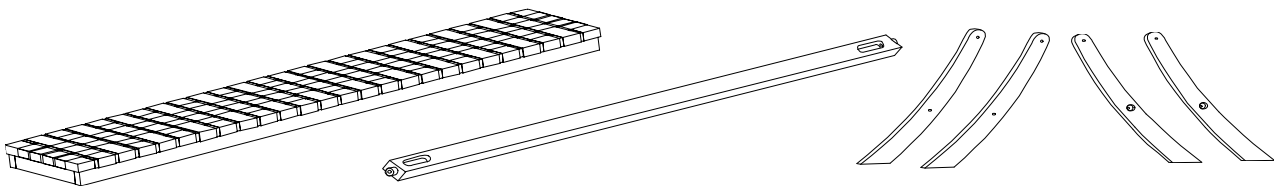

Unpack and place all parts on a clean, non-marring surface.

Step 2

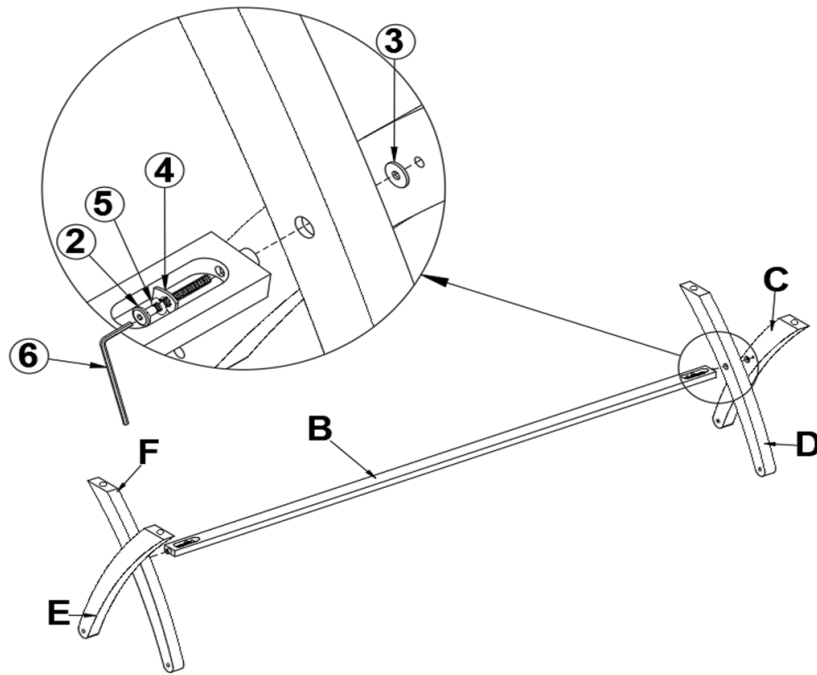

Place the First Leg (C), Second Leg (D), Third Leg (E) and Fourth Leg (F) (bottom-side up) on a non-marring surface.

With the help of your adult partner, align the Support Bar (B) into the position of the First Leg (C) and the Second Leg (D), Third Leg (E) and Fourth Leg (F), then secure using Plastic Washers (③), Crescent Washers (④), Spring Washers (⑤) and Bolts (②) with the Allen Key (⑥), as shown above.

Please note that the Plastic Washers (③) are supposed to be positioned between the First Leg (C) and the Second Leg (D); Third Leg (E) and Fourth Leg (F).

Do not fully tighten the Bolts.

Step 3

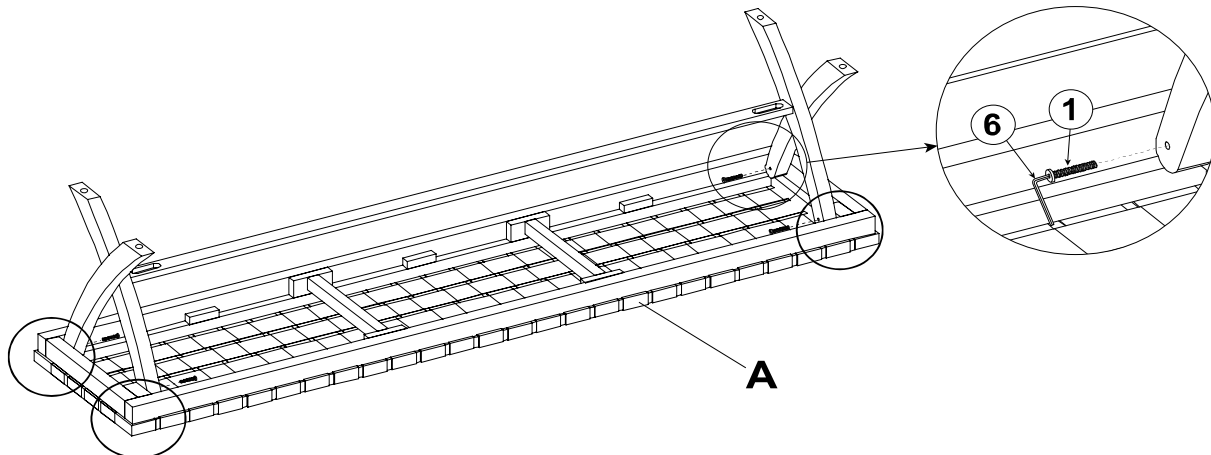

Place the Bench Top (A) face down on a non-marring surface.

Attach the assembled parts in Part 2 onto the Bench Top (A) using the Bolts (①) with the Allen Key (⑥), as shown above.

Do not fully tighten the Bolts.



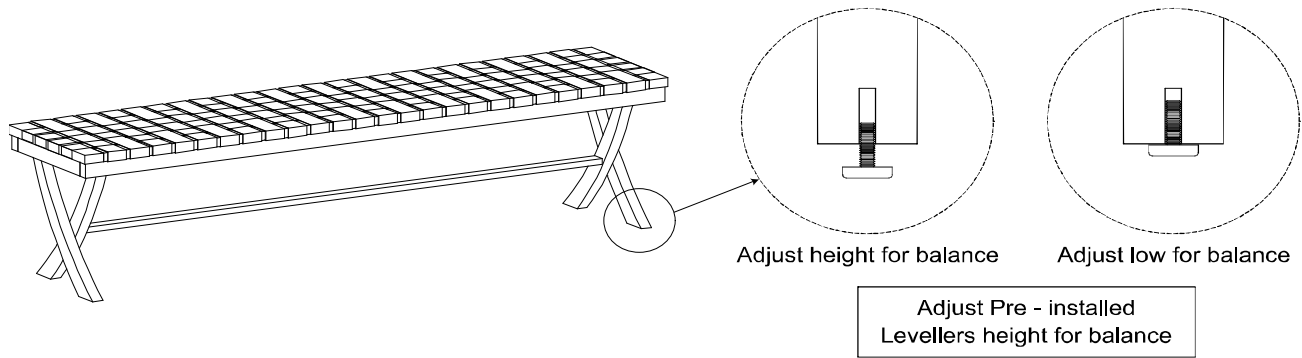

















Step 4



Turn the Bench upright carefully and place the Bench onto a flat, level surface. Then EXERT pressure floorwards onto the Bench with both hands. This pressure will help the Bench reach full alignment at all joints. In a sequential manner, gradually tighten all Bolts at all joints until evenly secured. Inspect the Bench and make sure all parts are adequately connected. Adjust the Levelers until the Bench is level with the ground. To adjust the Levelers, get assistance from an adult partner to lift/lean and hold the Bench while you are working.

Your Bench is ready for use.
This Bench can only be used on a flat, level surface.

Care & Maintenance

-   ● Do not put hot items directly on furniture surface
-   ● Do not clean furniture with harsh cleansers or polish.
-   ● To obtain the longest lifespan of your outdoor products, minimizing exposure to direct sunlight is recommended.
-   ● Children should not climb or jump on the furniture.
-   ● Do not write on furniture without a padded barrier to protect the surface.
-   ● To obtain the longest lifespan of your outdoor products, avoid extended and lengthy exposure to rain, snow, and direct sunshine. Whenever possible cover the product and /or place under patio or awnings.
-   ● Not for commercial use. For residential use only .
-   ● Stains may be removed with mild soap solution and damp cloth.
-   ● Keep away from sources of ignition.
-   ● Dust and pick-up spills using a clean, non-colored, lint-free cloth.