

# oline ErgoPro ERGONOMIC OFFICE CHAIR USER MANUAL

**oline**<sup>®</sup>

Customer Support  
Info@HeyOline.com

## Connect With Us

W HeyOline.com

Instagram OlineGoods

Twitter OlineGoods

YouTube Oline

Facebook OlineGoods

TikTok HeyOline

**oline**<sup>®</sup>



**oline** Ergo**Pro**  
ERGONOMIC  
OFFICE CHAIR  
**USER MANUAL**

●  
Thank you for purchasing the Oline ErgoPro Ergonomic Office Chair.  
Please read this manual carefully before using your office chair.  
Retain this manual for your reference.

The design and/or specification of this product is subject to change without notice.

# CONTENTS

<b>01</b>	Instructions for Safe Use .....	05
<b>02</b>	Assembly Parts .....	06
<b>03</b>	How to Assemble .....	07
<b>04</b>	How to Use .....	09
<b>05</b>	Product Specifications and Information .....	11
<b>06</b>	Customer Service Information .....	12
<b>07</b>	Product Registration and Warranty .....	13

## 01 Instructions for Safe Use











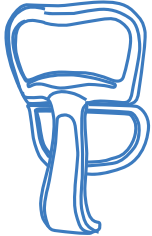

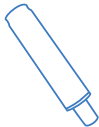

### ! PLEASE READ

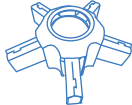
1. Do not discard any of the packaging until you are certain that you have all the necessary parts for the assembly.
2. Please ensure that the packaging is disposed of in a safe and environmentally responsible way.

### ! CAUTION

1. Never use this chair as a step ladder.
2. Check that screws have not loosened every 6 months. Retighten if necessary.
3. Do not allow children to play with or operate the mechanism.
4. Keep hands and feet clear of the mechanism.
5. Only the user should operate the mechanism.

## 02 Assembly Parts

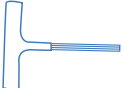
<b>(A) Chair Back x 1</b> 		<b>(B) Chair Seat x 1</b> 			
		<b>(C) Arms x1 (L) x 1 (R)</b> 			
<b>(D) Seat Mechanism x 1</b> 	<b>(E) Gas Lift x 1</b> 	<b>(F) Chair Legs x 5</b> 			
<b>(G) Chair Base x 1</b> 	<b>(H) Headrest x 1</b> 	<b>(I) Wheels x 5</b> 			
<b>(J) x 10</b> 	<b>(K) x 6</b> 	<b>(L) x 3</b> 	<b>(M) x 4</b> 	<b>(N) x 2</b> 	<b>(O) x 1</b> 
M6x0.55"	M6x1.18"	M8x0.79"	M6x0.79"	M6x0.79"	Allen Wrench

# 03 How to Assemble

## Step 1

Attach Chair Legs (F) to Chair Base (G1) using M6x0.55" Screws (J). Tighten with Allen Wrench (O).

## Step 2

Insert Wheels (I) into Chair Legs (F). Insert Gas Lift (E) into the hole in the center of the Chair Base (G1). Next, install the Base Cover (G2).

## Step 3

Attach Arms (C) to both sides of the Chair Seat (B) using M6x1.18" Screws (K). Tighten with Allen Wrench (O).

## Step 4

Attach Seat Mechanism (D) using M6x0.79" Screws (M). Tighten with Allen Wrench (O).

## Step 5

Attach Chair Back (A) to Chair Seat (B) using M8x0.79" Screws (L). Tighten with Allen Wrench (O).

## Step 6

Carefully place the assembled Chair Frame onto the Gas Lift (E). Press down on the Chair Seat (B) to secure in place. Attach Headrest (H) to Chair Back using two M6x0.79" Screws (N). Tighten with Allen Wrench (O).

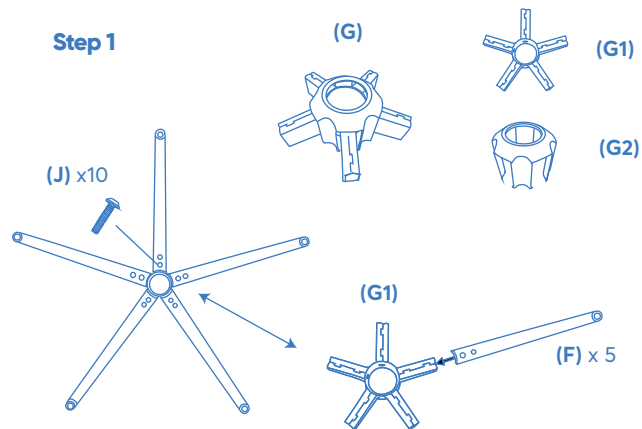

## Step 2

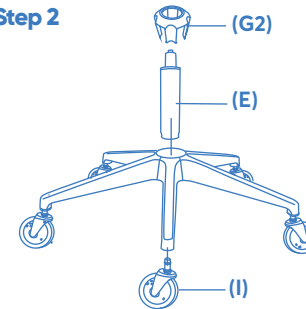

## Step 3

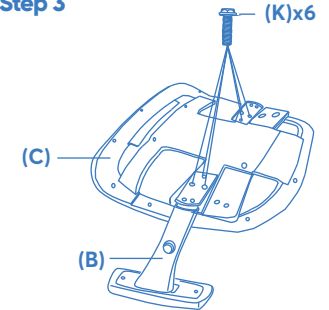

## Step 4

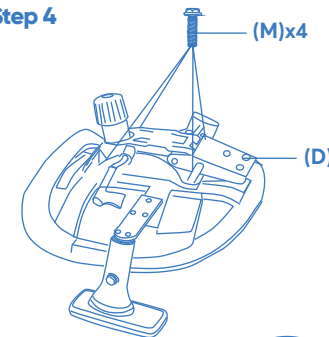

## Step 5

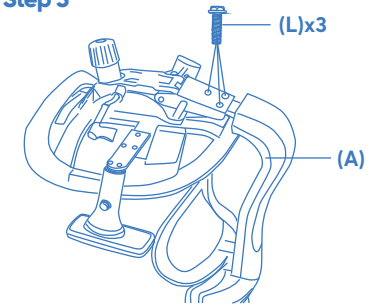

## Step 6

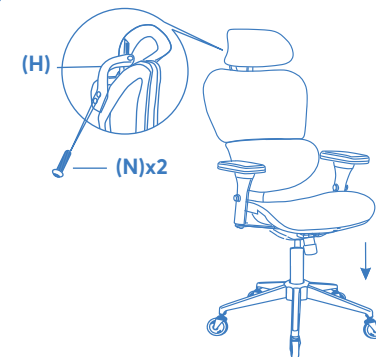

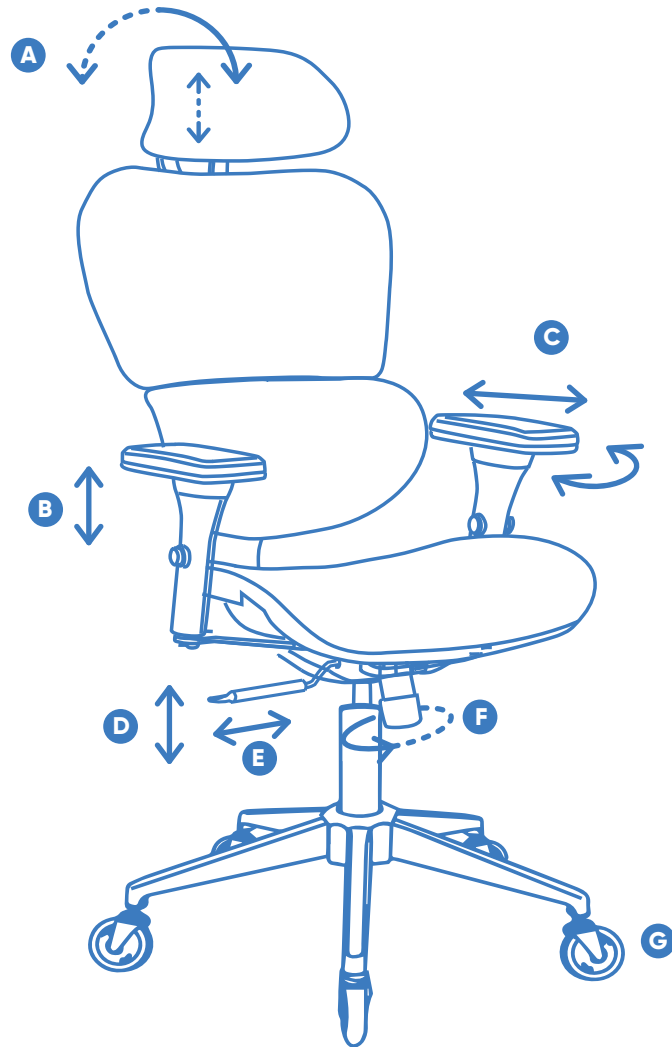

### **A HEADREST**

Move the headrest up or down to adjust the height. Angle the headrest upward/downward.

### **B 4-DIRECTIONAL ARMRESTS - HEIGHT**

Press and hold the outer side button and pull the armrest up or down to adjust the height.

### **C 4-DIRECTIONAL ARMRESTS - DIRECTION**

Push the armrests to adjust 1) from side to side, 2) forward and backward, and 3) pivot outwards and inwards.

### **D HEIGHT**

Pull the 'flap' of the handle up to adjust the height of the chair.

### **E TILT MECHANISM**

Right handle (while seated): Push inwards/pull outward to lock/unlock the tilt mechanism. If in the reclined position and the tilt mechanism is unlocked, give the backrest a slight push to release. Three tilt locking positions: upright, middle and fully reclined.

### **F TILT TENSION**

Turn the knob counter-clockwise to loosen the tilt of the chair, clockwise to tighten. Adjust according to your own preference.

### **G BLADE WHEELS**

Best suited for hardwood and tile floors. They glide silently and smoothly.

## 05 Product Specifications and Information

<b>Product Name</b>	ErgoPro
<b>Model Number</b>	OLN-ERGOPRO
<b>Chair Dimensions</b>	W27.95 x D27.16 x H44.09/49.01 in
<b>Seat Depth</b>	16.3"
<b>Max Hip Width</b>	19.7"
<b>Net Weight</b>	45.20 lbs
<b>Gross Weight</b>	51.80 lbs
<b>Weight Capacity</b>	85 lbs - 275 lbs
<b>Height Capacity</b>	5'4" - 6'1"
<b>Fabric</b>	HD ElastoMesh Back and Seat with soft PU Coated Armrests
<b>Wheels</b>	XL Blade Wheels
<b>Base</b>	5-Point Electroplated Steel Wheelbase
<b>Customer Service</b>	Info@HeyOline.com

## 06 Customer Service Information

Oline Office chairs are warranted for a period of 5 years against:

1. Missing materials from the Product at the time of delivery;
2. Defects in the manufacturing of materials used for the Products at the time of delivery
3. Failure of the Products to correspond with the description in the applicable contract of sale at the time of delivery; and
4. Major defects in the functional department, such as:
  - a. Skeletal frame failure
  - b. Wheel mechanism failure
  - c. Tilt mechanism failure
  - d. Gas lift failure
  - e. Armrest mechanism failure

### Subject to the following

Any replacement parts shall be sent to the address of the original purchaser. Replaced parts may be required to be shipped back to Oline at its discretion. To benefit under this warranty, Oline must be notified of any defect within 7 days of the occurrence of such defect via an image or video of the defect sent electronically to Info@HeyOline.com, and after inspection and acceptance by Oline; to the extent permitted under the applicable Federal and State law of the United States of America, all parts replaced or repaired under this warranty shall be warranted to the remainder of the designated Warranty Period.

### What Our Warranty Does Not Cover

All warranties listed on this page exclude the following where permitted under the applicable Federal and State law of the United States of America:

1. Excludes normal wear and tear of surfaces that are not attributable to manufacturing, including but not limited to (a) degradation of upholstery (PU leather/fabric/genuine leather/mesh), top portion of armrests, pillows, casters exterior or mesh stitching, (b) damage to plastic coverings, (c) variance of tightness of mechanisms, and (d) excludes damage from accidents, natural disasters, physical damage from pets, fire, and flood, and non-manufacturing incidents covered under insurance policies (regardless of whether you are in possession of the relevant insurance, (e) excludes any variations in dimensions and color;
2. Any claims for indirect, consequential or incidental losses.
3. Damage to a product that has been modified or altered without the written permission of Oline;
4. Damage caused to all Oline products during self-assembly due to failure to adhere to the relevant self-assembly manual instructions provided;
5. Minor misalignments, variations arising out of hand-made workmanship. To ensure your product enjoyment and safety, and protection under the "Warranty Period", please ensure you have Oline assembly and care guidelines for this product, and follow them for the correct assembly and care for your item. Contact our Customer Service Team to obtain these guidelines if you do not have them.

oline®

**ACTIVATE YOUR  
FREE WARRANTY NOW**

Please register your office chair within 7 days  
after receiving to activate your warranty.

Make sure you do this **NOW** to  
ensure your purchase is  
**100% covered.**  
It takes only 30 seconds.

**REGISTER ONLINE NOW!**

[www.HeyOline.com/Warranty](http://www.HeyOline.com/Warranty)

Customer Support: [Info@HeyOline.com](mailto:Info@HeyOline.com)

Thank you.

oline®