

INSTRUCTION MANUAL

Dining Table

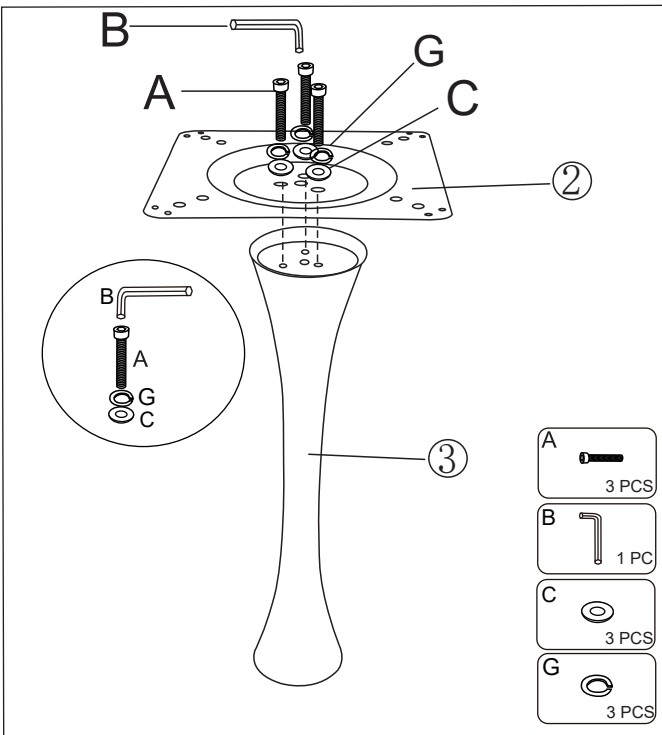



- A 3 PCS
- B 1 PC
- C 3 PCS
- G 3 PCS

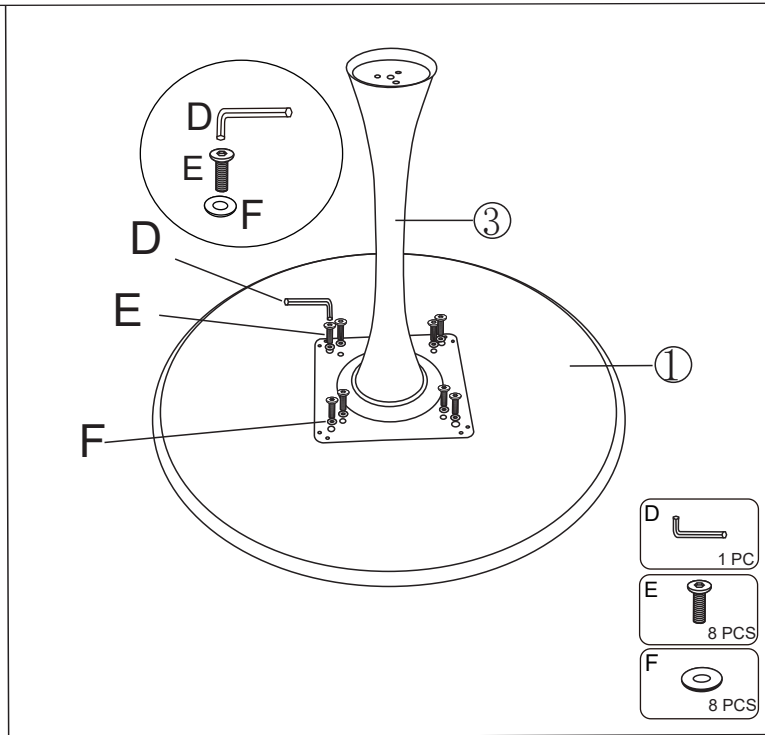

- D 1 PC
- E 8 PCS
- F 8 PCS

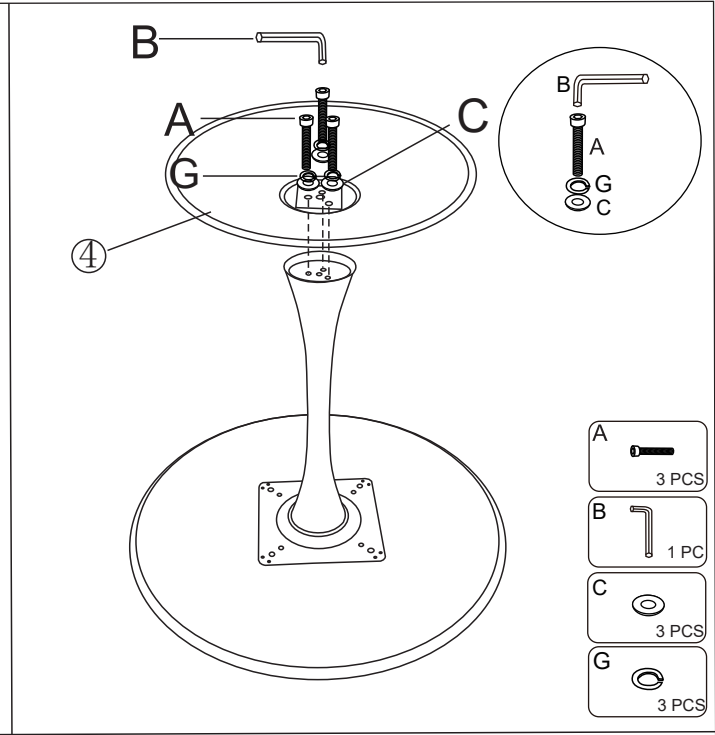

- A 3 PCS
- B 1 PC
- C 3 PCS
- G 3 PCS



①		1	B		1
②		1	C		6
③		1	D		1
④		1	E		8
A		6	F		8
			G		6

HELP CENTER

For any inconvenience caused by product quality problems, please contact us through any of the above two contact methods, and we are willing to provide compensation.



Chat Support



Product Inquiry



Orders FAQ



Product Assembly



Returns & Refunds

PRODUCT WARRANTY INFORMATION

All items can be returned for any reason within 30 days of the receipt and will receive a full refund as long as the item is returned in its original product packaging and all accessories from its original shipment are included.

All returned items require an RA (Return Authorizaton) number, which can only be provided by a Brand Customer Service Representative when the return request is submitted. Items received without an RA may not be accepted or may increase your return processing tme. Once an item has been received, refunds or replacements will be processed within 5 business days.

All returns must be shipped back to the Brand Products Return Center at the customer's expense. If the reason for the return is due to a product manufacturing error then we will provide a pre-paid shipping label via email.

Pictures may be required for some returns to ensure an item is not damaged prior to its return.