

# User Manual

Instruction for Assembly 6' \* 8' Metal Shed

**JAXPETY**

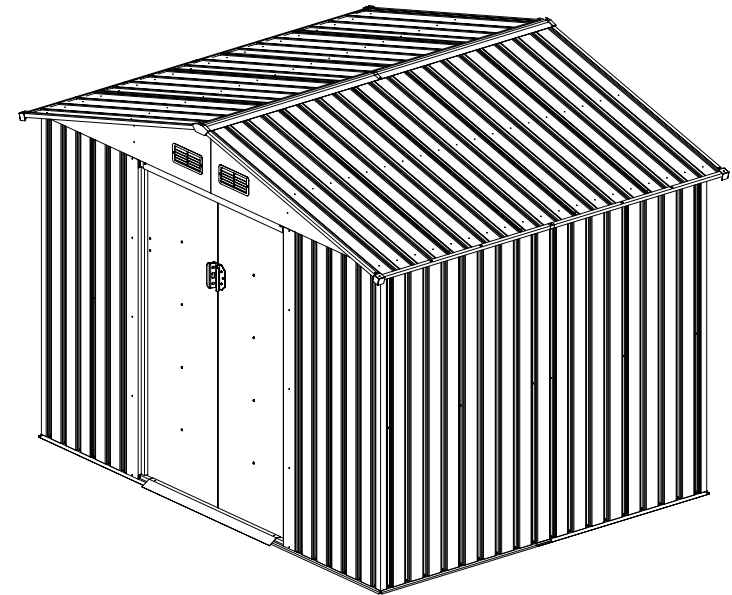

**JAXPETY**

## Assembly Preparation

### Owner's Manual

Please check local building codes regarding footings, location and other requirements before beginning construction.

### Assembly instructions:

Reviewing all instructions and the appropriate information before you begin, make sure following the step sequence carefully for successful results.

### Flooring base:

A good location for the storage building is a square and level area with good drainage. The base is not included in the kit which may need purchase separately or may construct a foundation and anchoring system of your own.

A strong plastic sheet (thickness: at least 150µm) should be placed under the foundation to assist in reducing rising dampness from the soil, thus reducing condensation build up in the shed. Your storage building must be anchored to prevent wind damage. Once secured, it is highly recommended applying silicone along the inside of the base rail to minimize condensation.

### Parts and Parts List:

Before you start, separate and identify all the parts and hardware to be sure that you have all the necessary parts for your building (refer to the Parts List Page).

If you find that a part is missing, please notify the seller within one week after receiving the product. Do not attempt to assemble the building if parts are missing because any building left partially assembled may be seriously damaged by light winds.

### Tools you need:

( Please tear off the safety protection layer before the assembly, keep the part number label if needed )

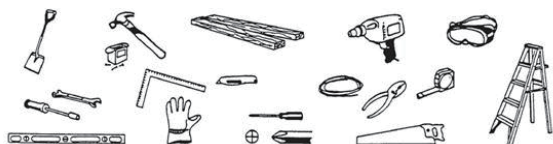

### Safety must be put in the No. 1 position:

1. Select a dry and calm day for your assembly. Team works (Two or more people) are required during the assembly. It is also recommended to finish the assembly in a day to avoid damage to the product or missing of some small parts.
2. Wearing safety gloves, eye protection and long sleeves during the assembly to prevent injury. Pay attention to the sharp edge of some parts.
3. Children and pets are not allowed entering into the construction site.
4. Never concentrate your total weight on the roof of the building. When using a step ladder make sure that it is safe.

### Care & Maintenance:

1. Keep the shed clean with soft cloth, use water if necessary.
2. Keep the door tracks clear of dirt and other stuff that prevent them from sliding easily.
3. Clean the snow with necessary tools to make sure it is safe to enter into.
4. The shed is not made for living but storing stuff.
5. Please add some oil on the top and bottom door sliding channel to make door slides smoothly.

## Size:

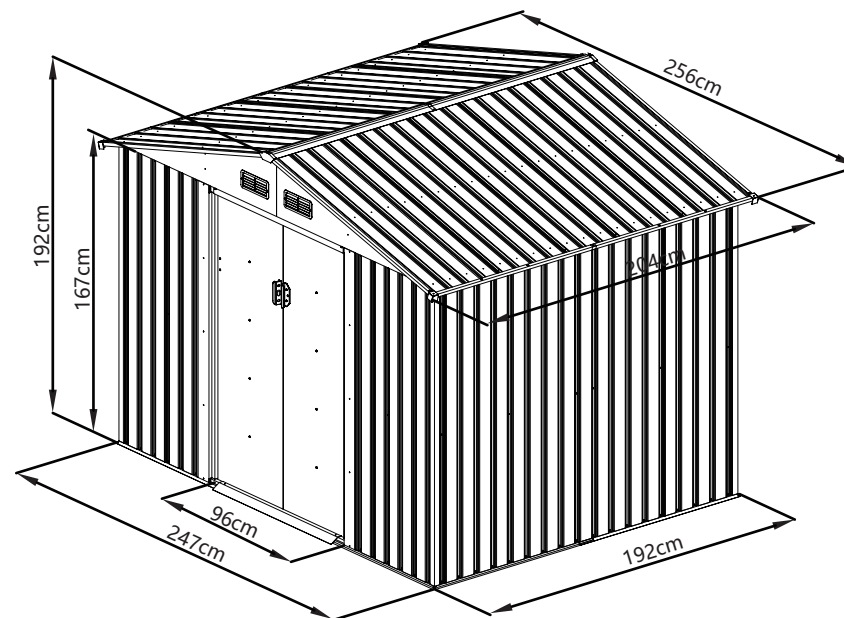

## Area of installation requirement:

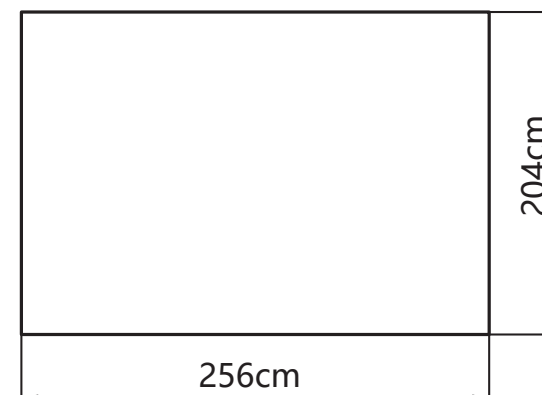



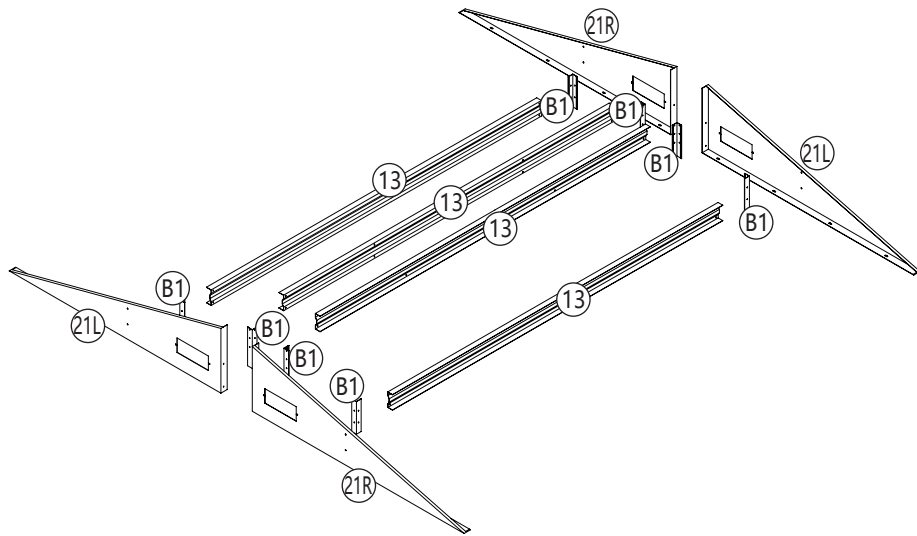
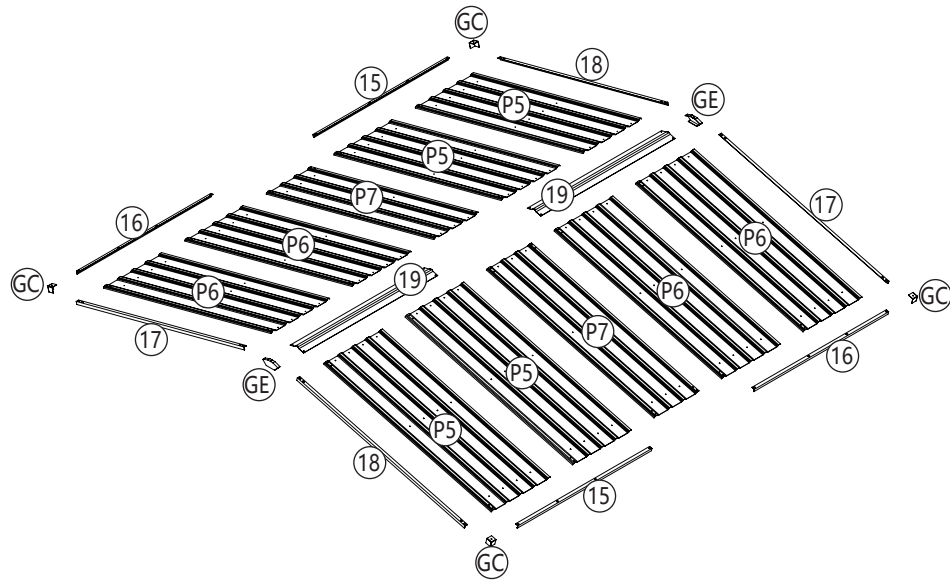



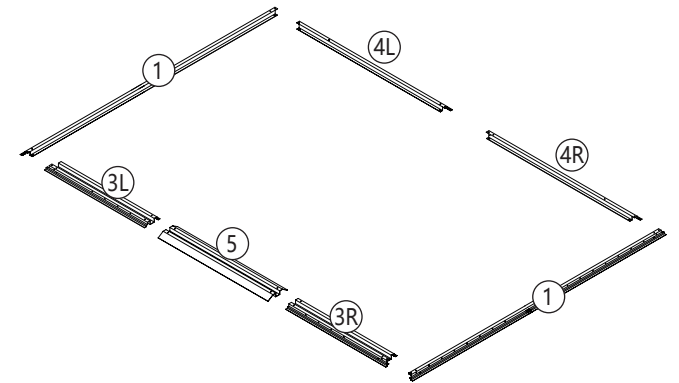
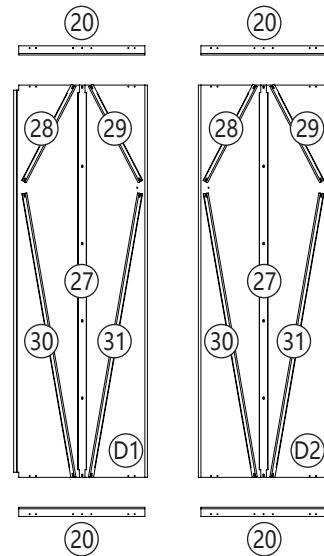
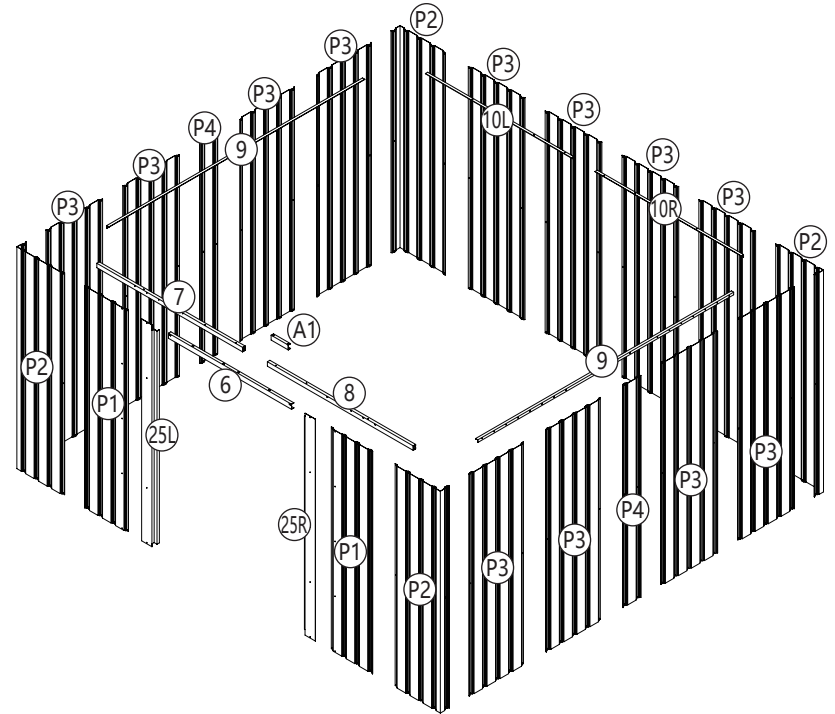

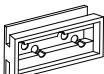
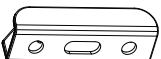

PRODUCT ASSEMBLY



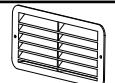





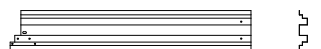
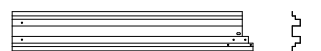

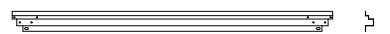
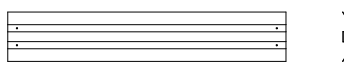
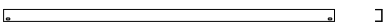
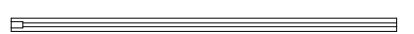
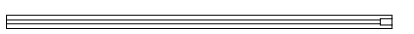



PRODUCT ASSEMBLY



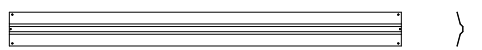

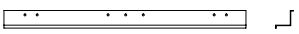
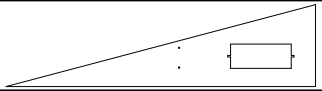
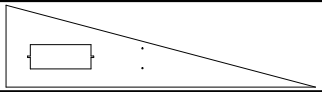
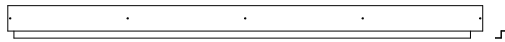
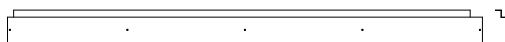
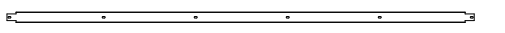
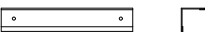

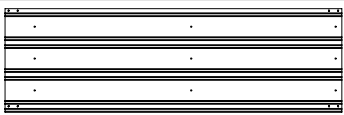
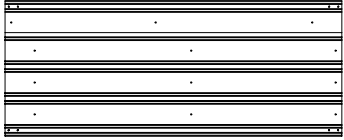

# Hardware List

PART	NO.	Qty.	Box No.
	G2	4	3/3
	GB	2	1/3
	GC	4	1/3
	GD	4	1/3
	GE	2	1/3
	GF	4	1/3
	F1	292	1/3
	F2	89	1/3
	F3	8	1/3
	S1	156	1/3
	S2	357	1/3
	1	2	3/3
	3L	1	3/3
	3R	1	3/3

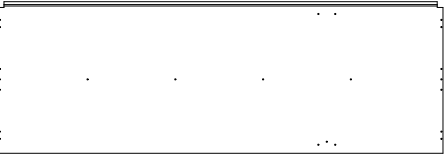
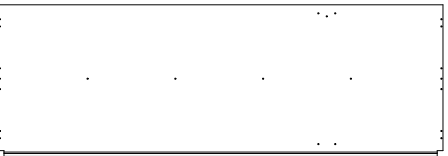
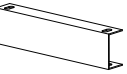
PART	NO.	Qty.	Box No.
	4L	1	3/3
	4R	1	3/3
	5	1	3/3
	6	1	1/3
	7	1	3/3
	8	1	3/3
	9	2	3/3
	10L	1	3/3
	10R	1	3/3
	13	4	3/3
	15	2	3/3
	16	2	3/3
	17	2	3/3
	18	2	3/3
	19	2	1/3

PART	NO.	Qty.	Box No.
	20	4	1/3
	21L	2	1/3
	21R	2	1/3
	25L	1	2/3
	25R	1	2/3
	27	2	3/3
	B1	8	3/3
	P1	2	1/3
	P2	4	2/3
	P3	12	1/3
	P4	2	2/3

PART	NO.	Qty.	Box No.
	P7	2	2/3
	P5	4	2/3
	P6	4	2/3
	D1	1	2/3
	D2	1	2/3
	A1	1	3/3
	28	2	3/3
	29	2	3/3
	30	2	3/3
	31	2	3/3

PRODUCT ASSEMBLY

⚠ Check the package contents before getting started !

STEP 1

F1		X12
----	---	-----

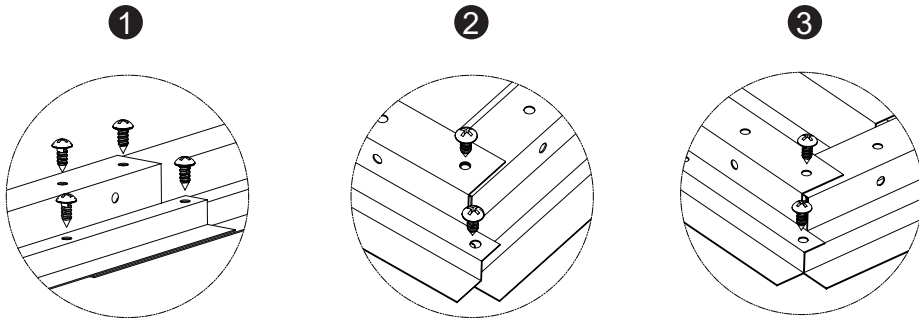
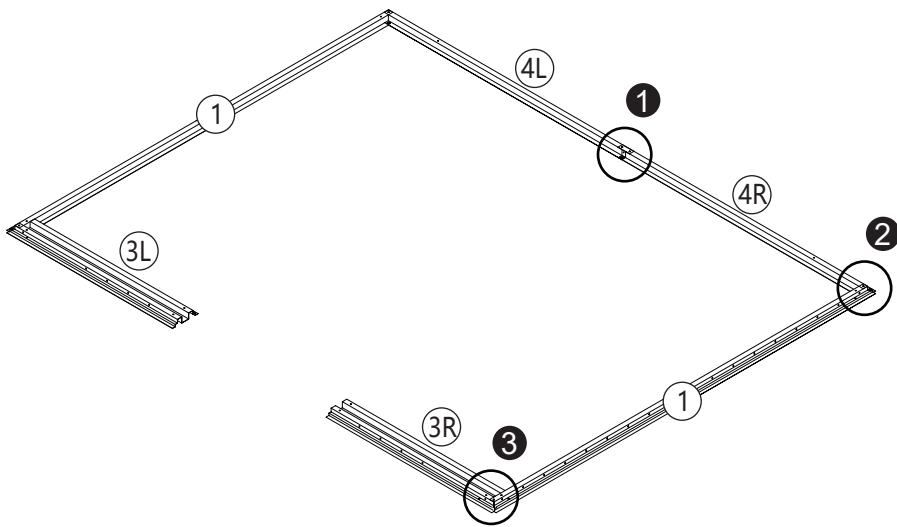

PRODUCT ASSEMBLY

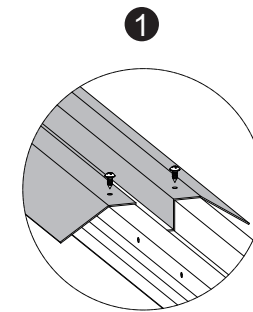
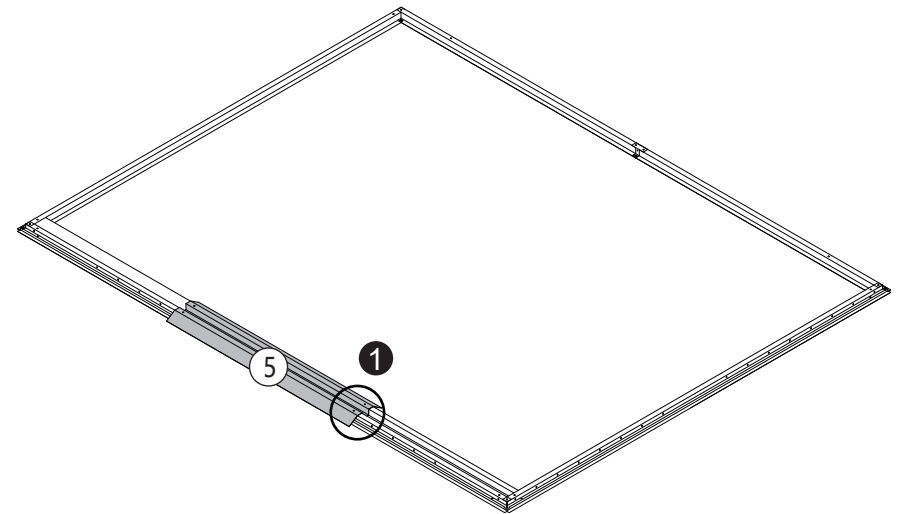

STEP 2

F1		X4
----	---	----



PRODUCT ASSEMBLY

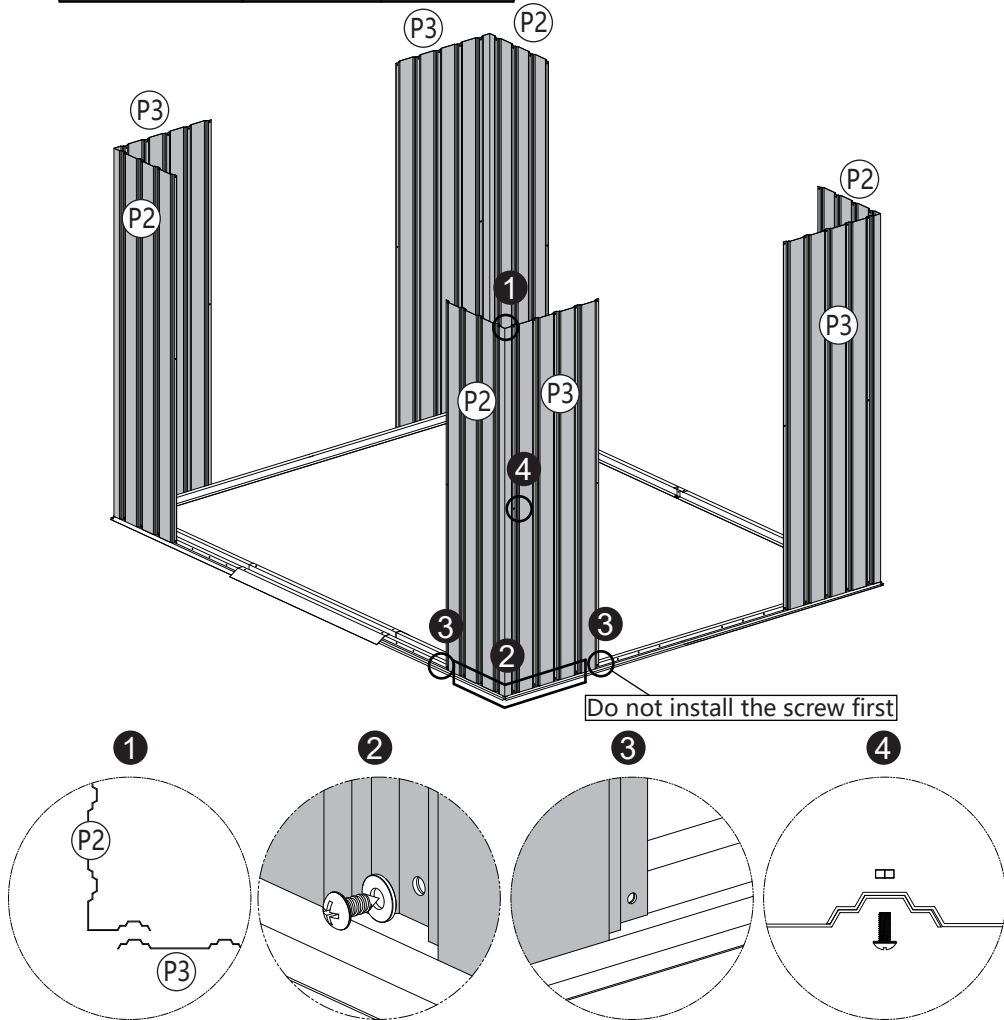

STEP 3

S2		X28
F1		X28
F2		X4



PRODUCT ASSEMBLY

STEP 4

S2		X16
F1		X16

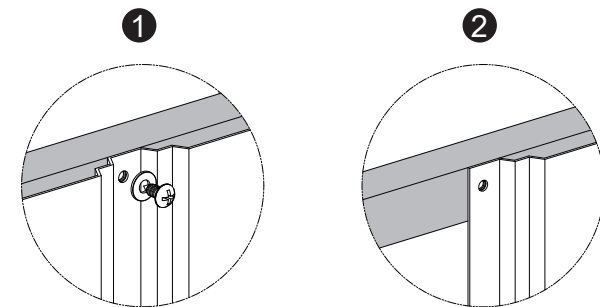
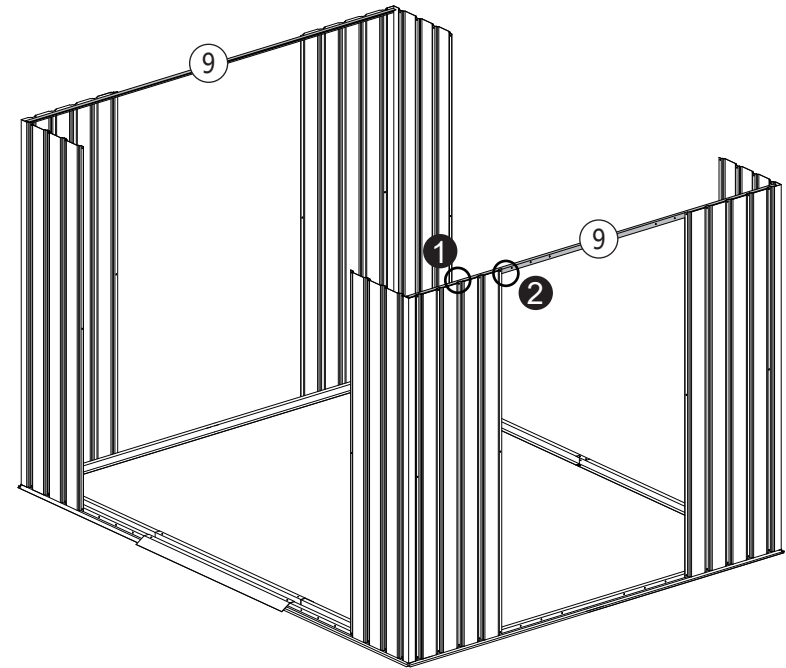

PRODUCT ASSEMBLY

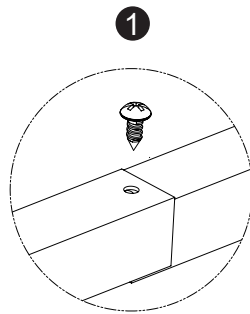
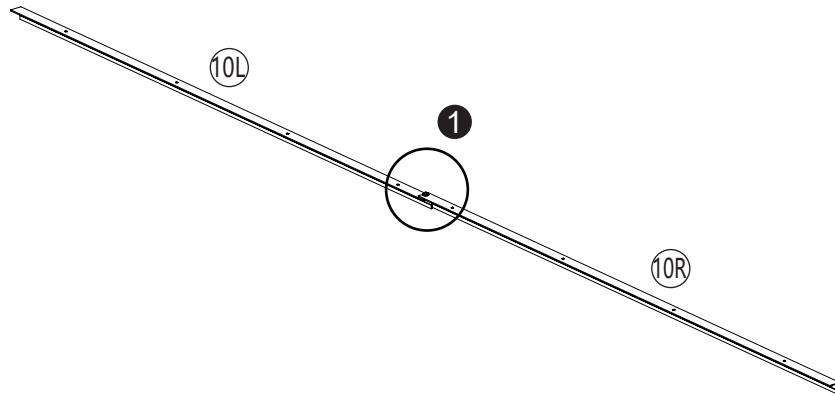

STEP 5

F1		X1
----	---	----



PRODUCT ASSEMBLY

STEP 6

S2		X6
F1		X6

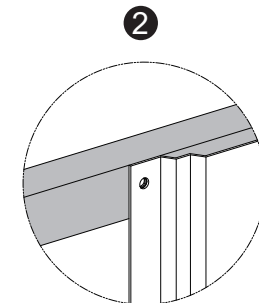
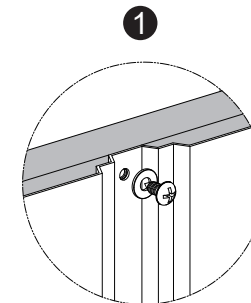
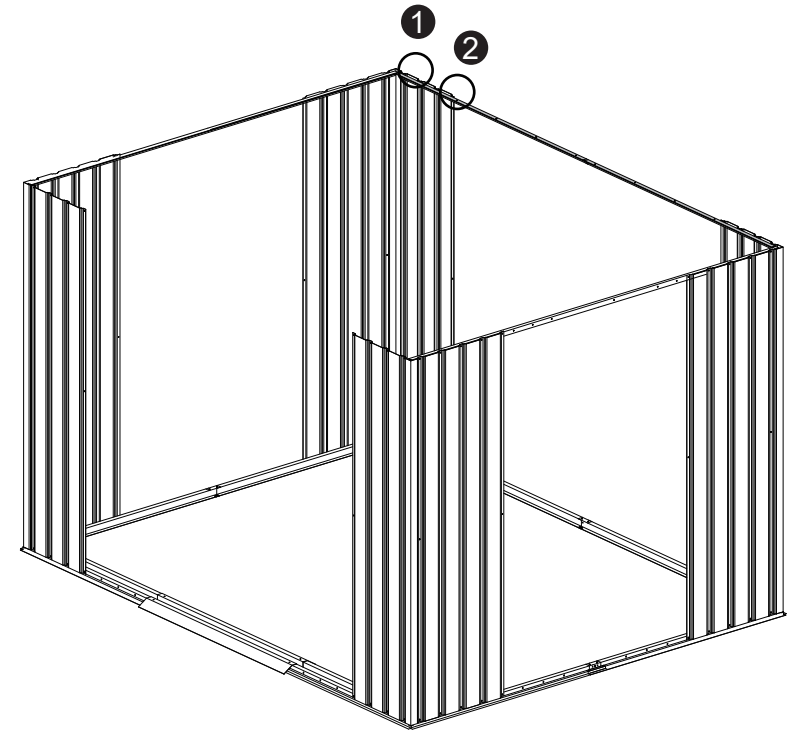

PRODUCT ASSEMBLY

STEP 7

G2		X4
----	---	----

⑦ & ⑧

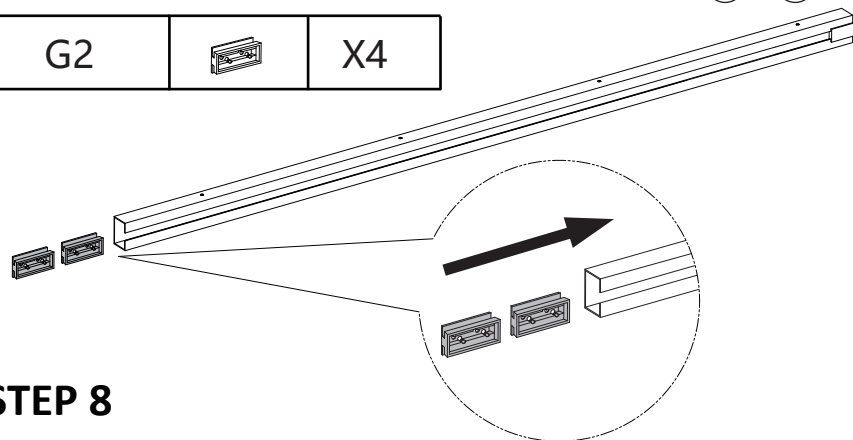

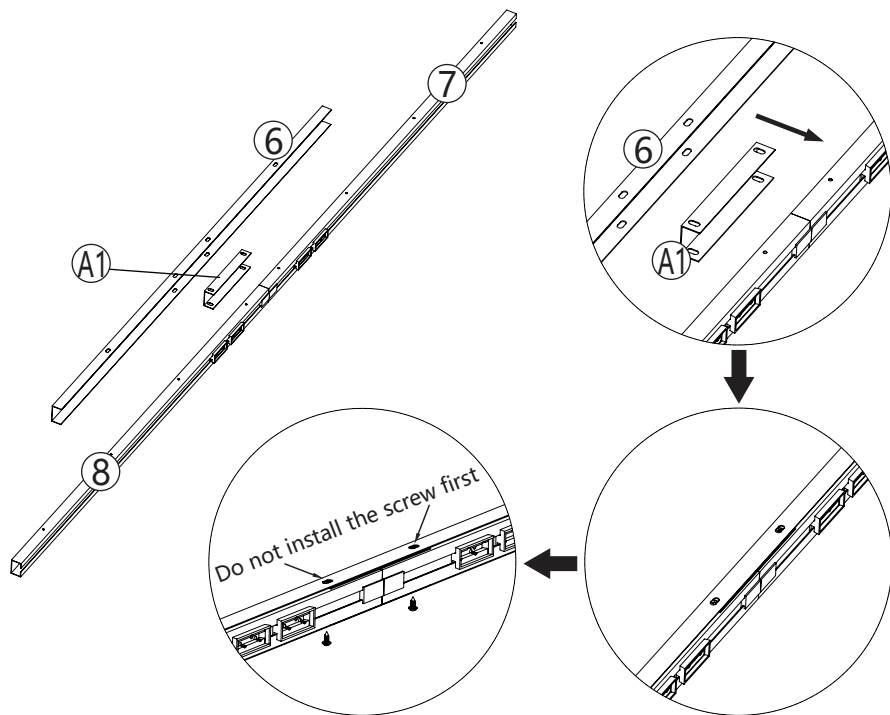

STEP 8

F1		X2
----	---	----



PRODUCT ASSEMBLY

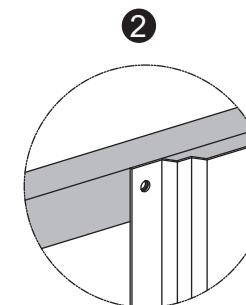
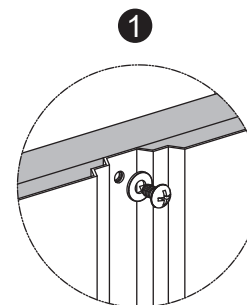
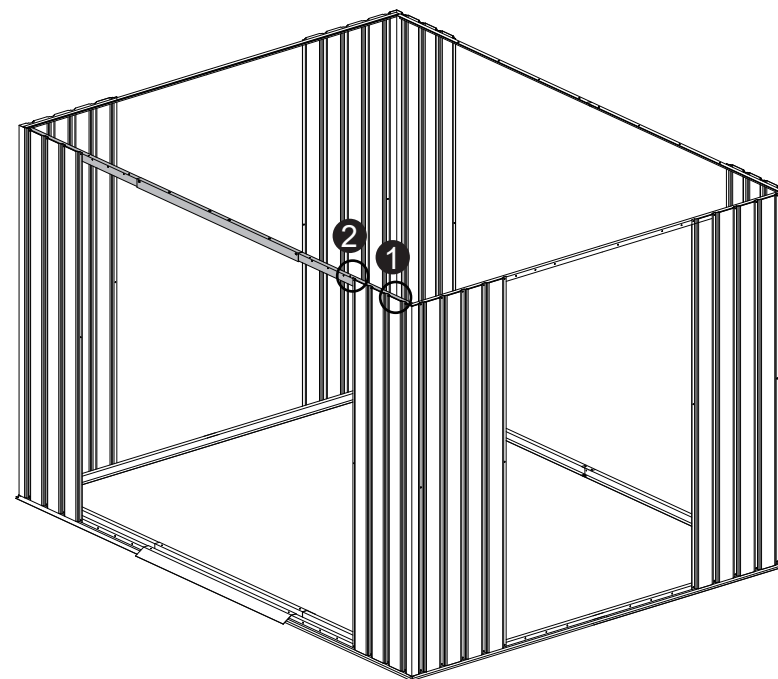

STEP 9

S2		X6
F1		X6



PRODUCT ASSEMBLY

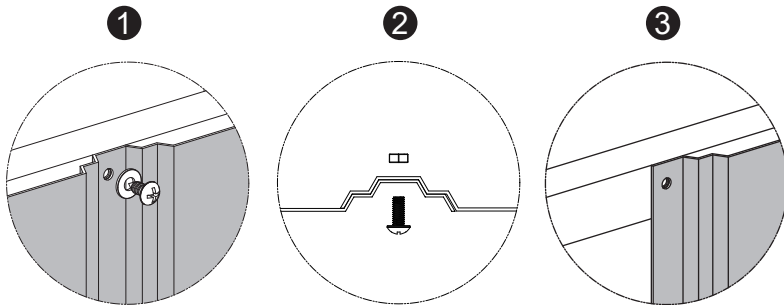
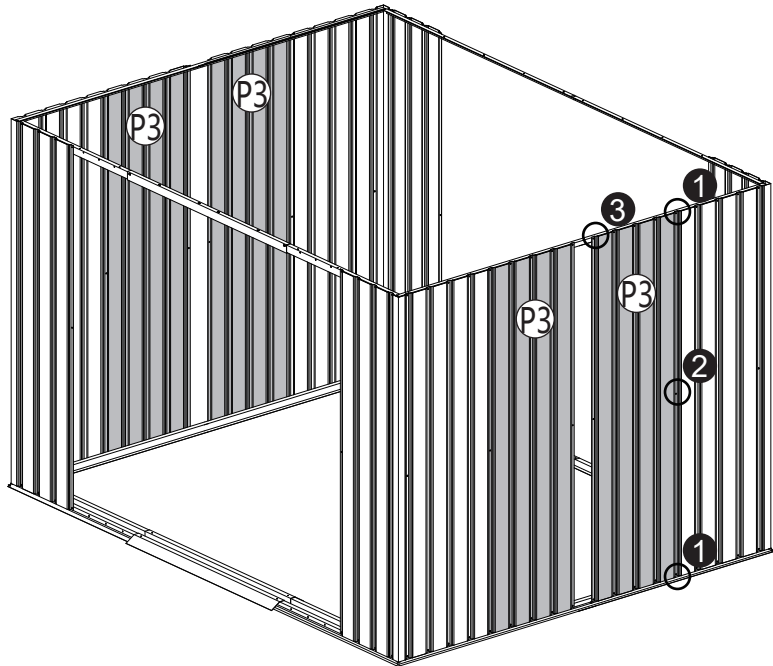

STEP 10

S2		X16	F2		X4
F1		X16			



PRODUCT ASSEMBLY

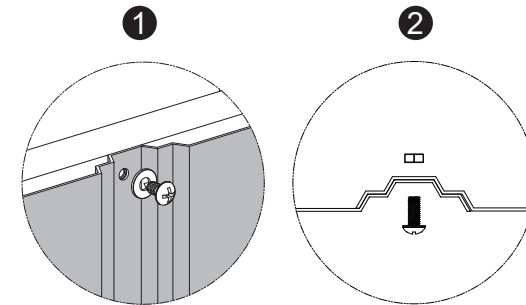
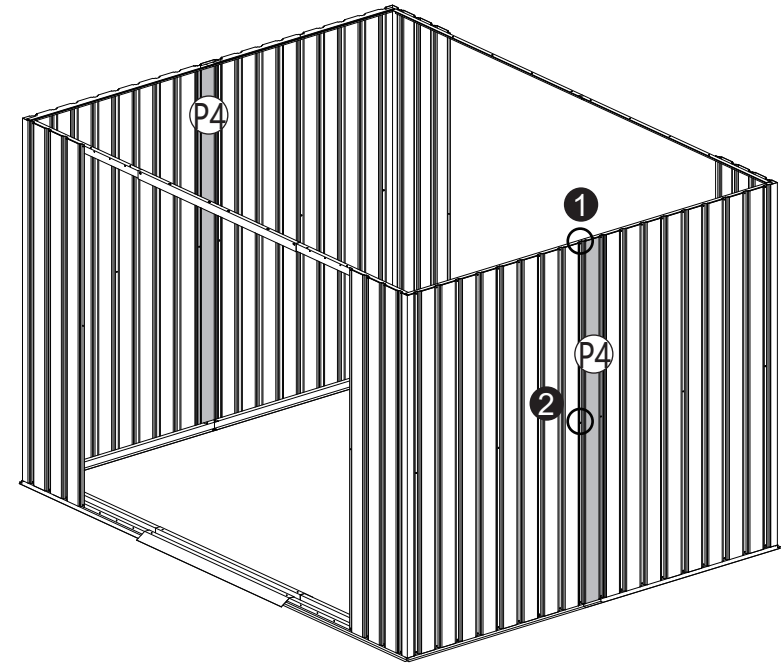

STEP 11

S2		X8	F2		X4
F1		X8			



PRODUCT ASSEMBLY

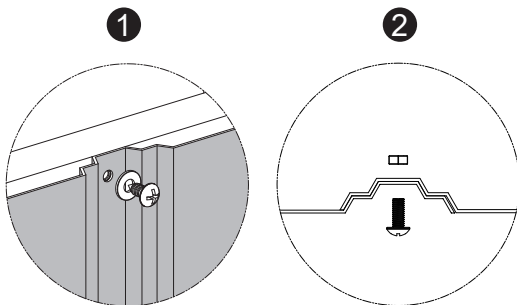
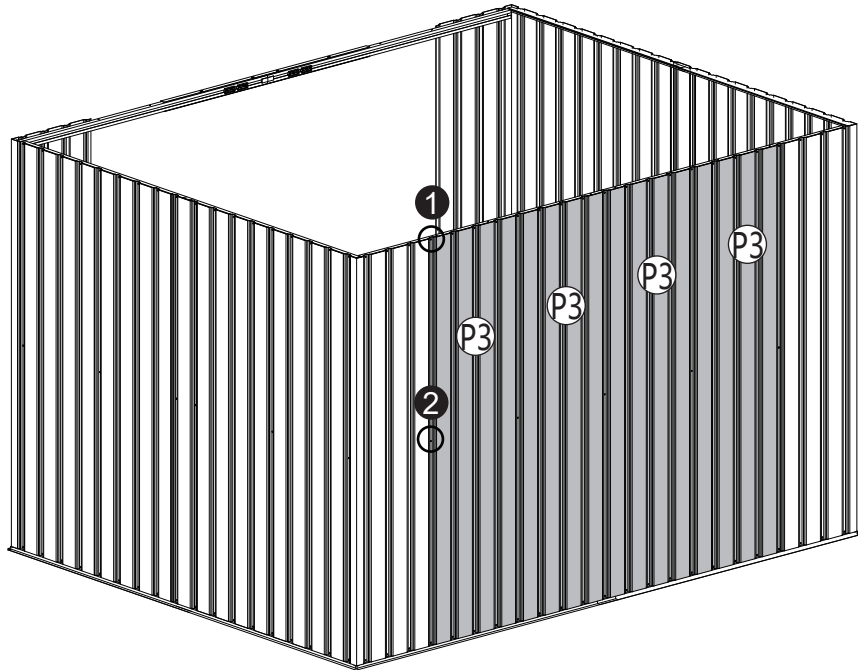

STEP 12

S2		X34	F2		X5
F1		X34			



PRODUCT ASSEMBLY

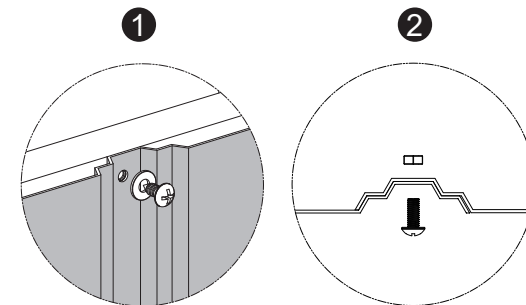
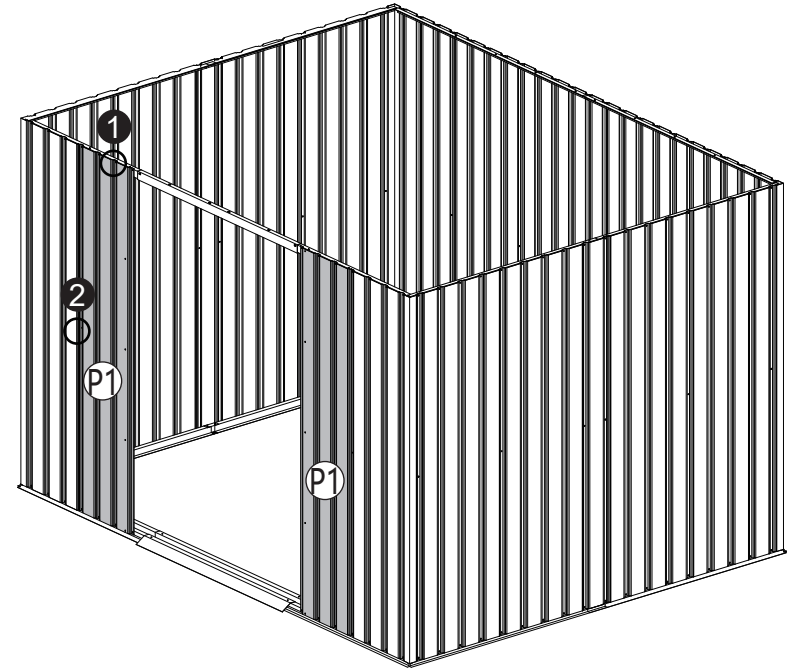

STEP 13

S2		X16	F2		X2
F1		X16			



PRODUCT ASSEMBLY

STEP 14

S2		X4	F2		X6
F1		X4			

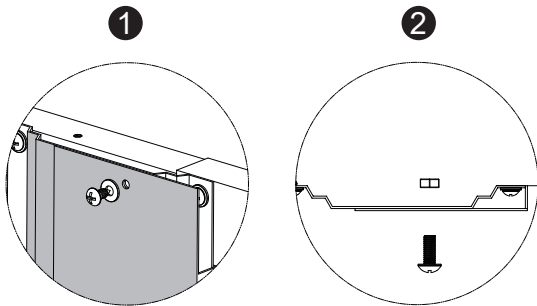
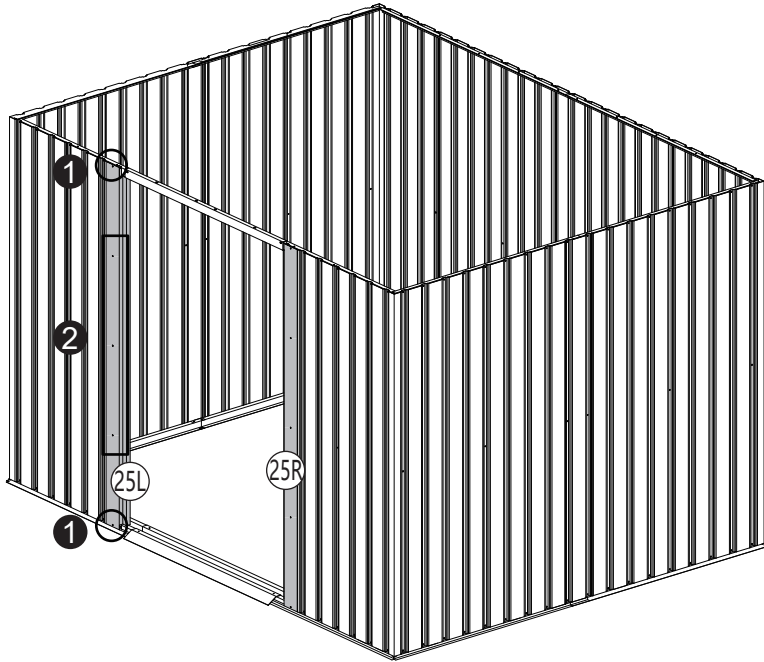

PRODUCT ASSEMBLY

STEP 15

GF		X4	F2		X8
----	---	----	----	---	----

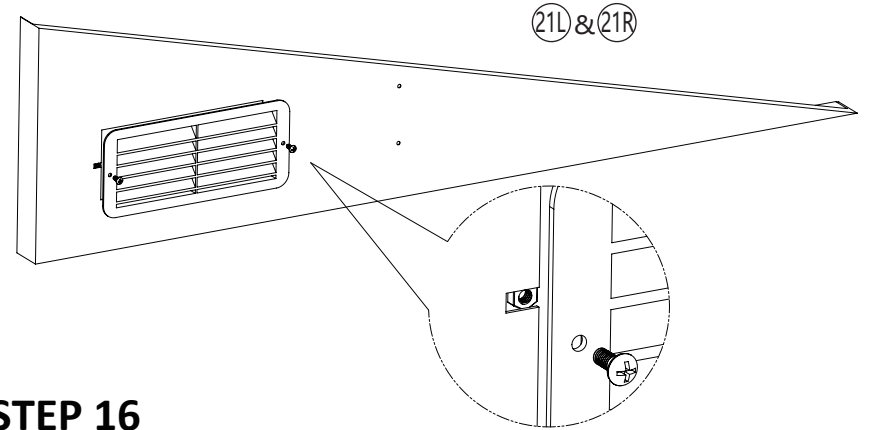

STEP 16

F2		X8
----	---	----

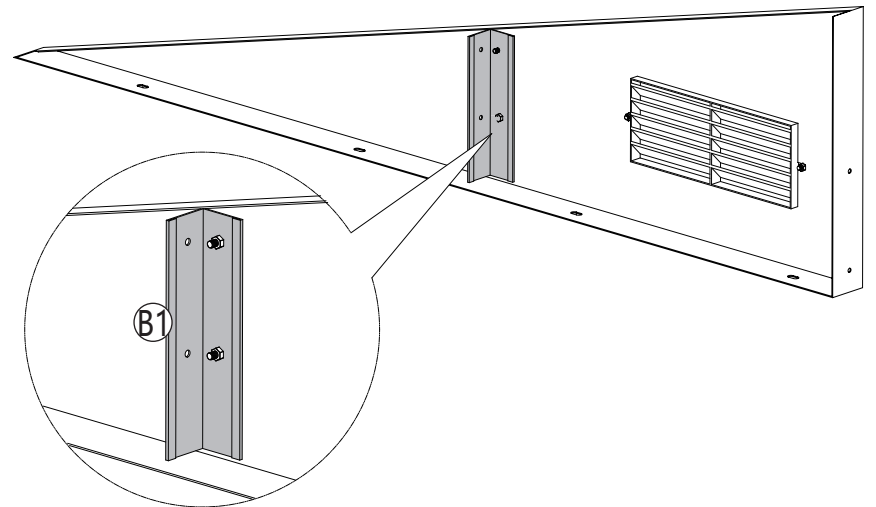

PRODUCT ASSEMBLY

STEP 17

F2		X4
----	---	----

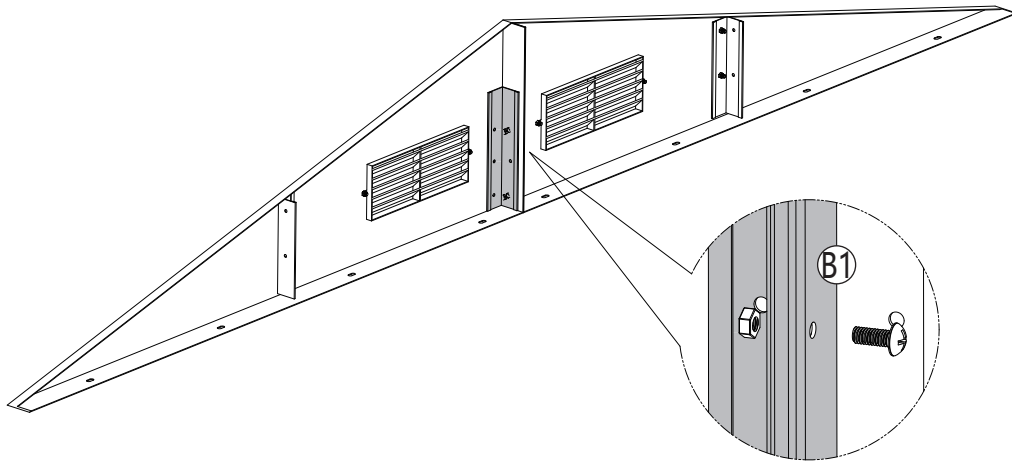

PRODUCT ASSEMBLY

STEP 18

F1		X16
----	---	-----

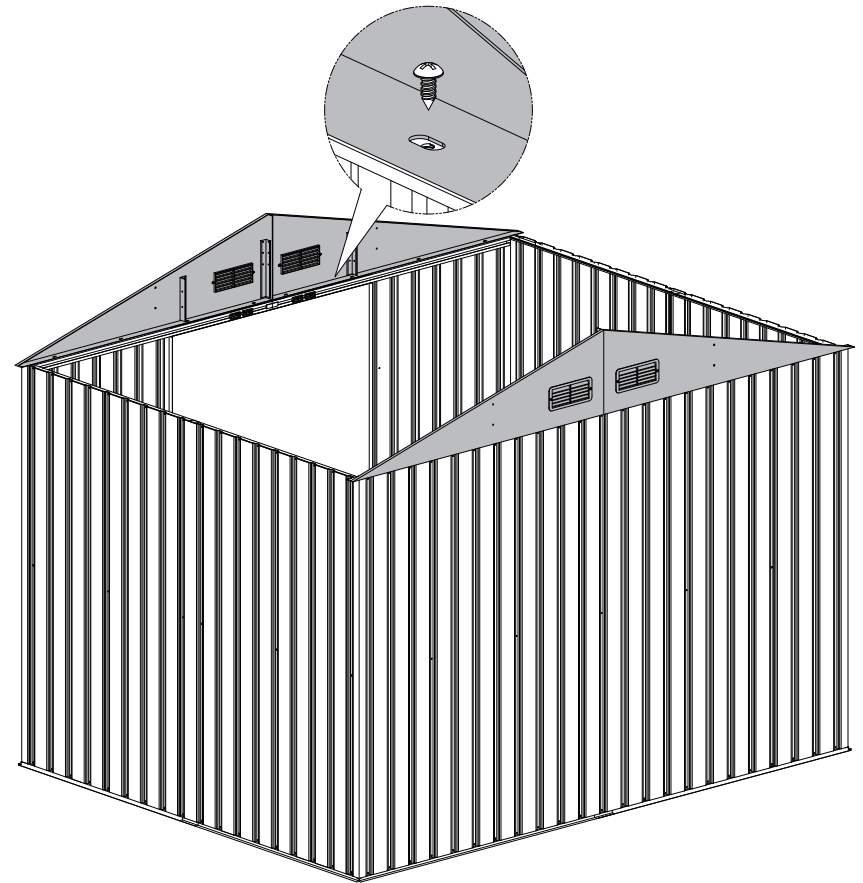

PRODUCT ASSEMBLY

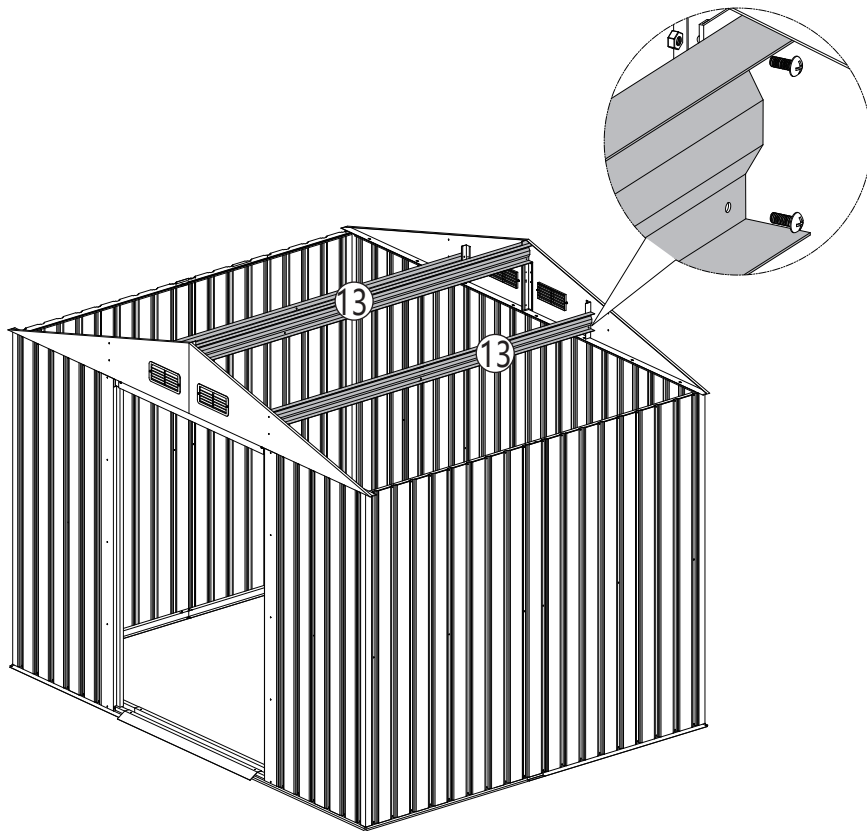

STEP 19

F2		X12
----	---	-----



PRODUCT ASSEMBLY

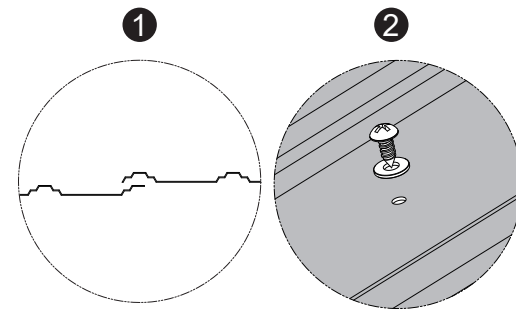
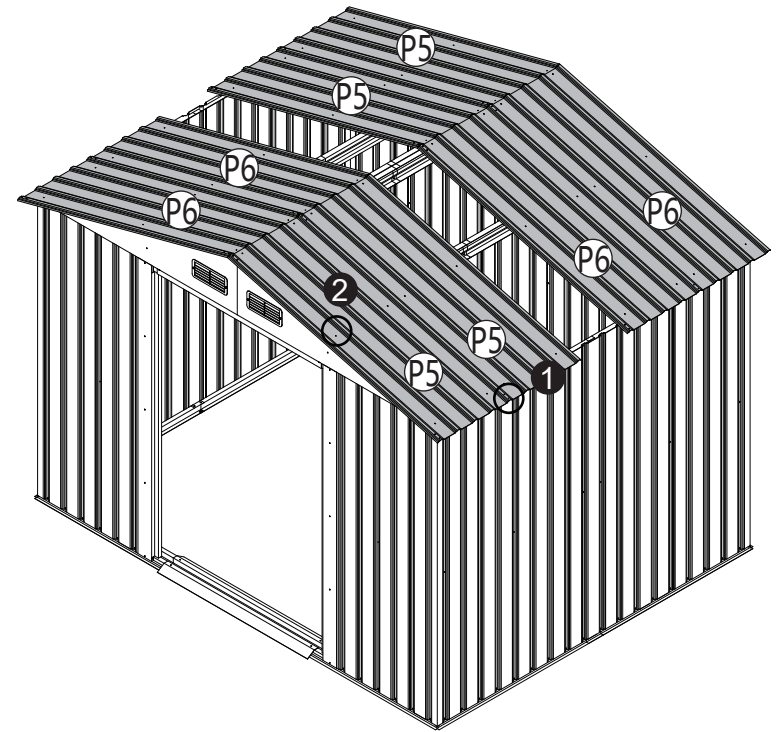

STEP 20

S2		X48	F1		X48
----	---	-----	----	---	-----



PRODUCT ASSEMBLY

STEP 21

S2		X12	F1		X12
----	---	-----	----	---	-----

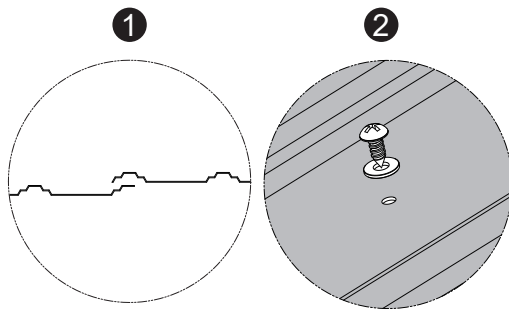
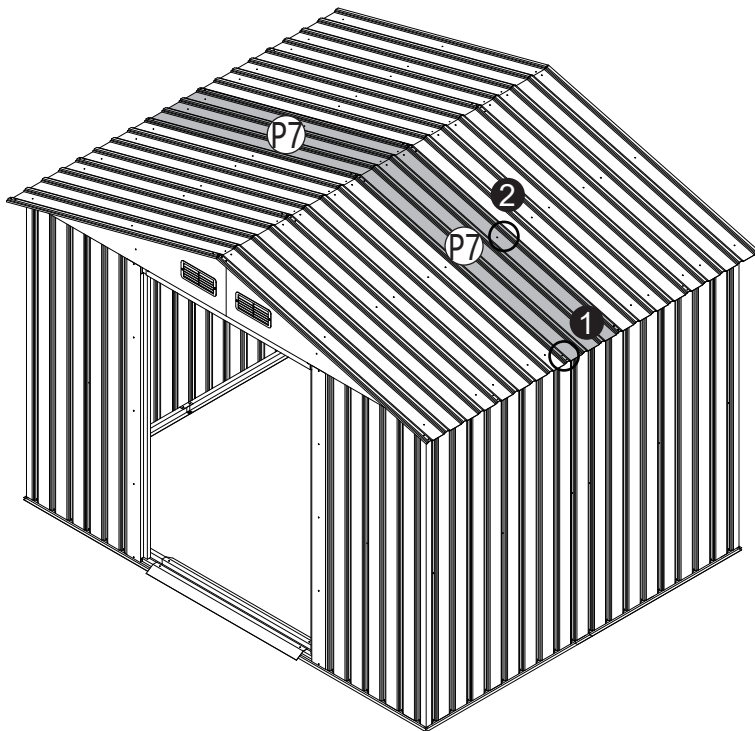

PRODUCT ASSEMBLY

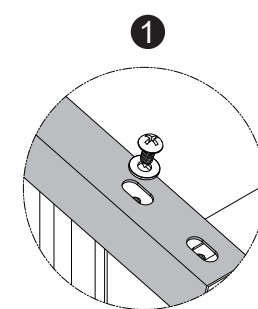
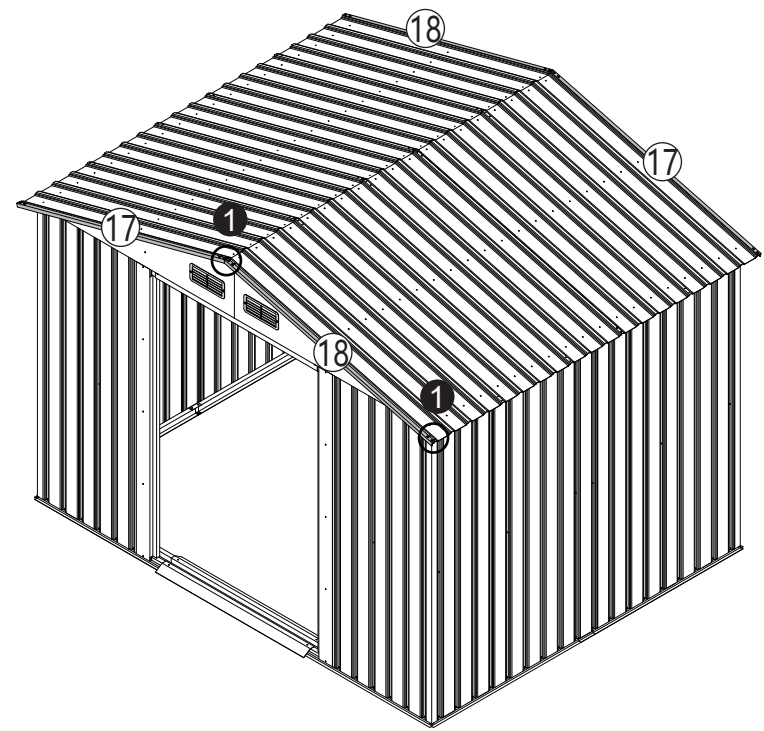

STEP 22

S2		X8	F1		X8
----	---	----	----	---	----



PRODUCT ASSEMBLY

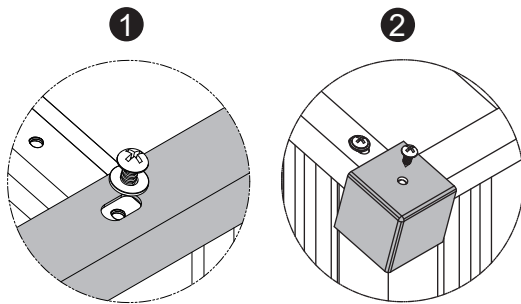
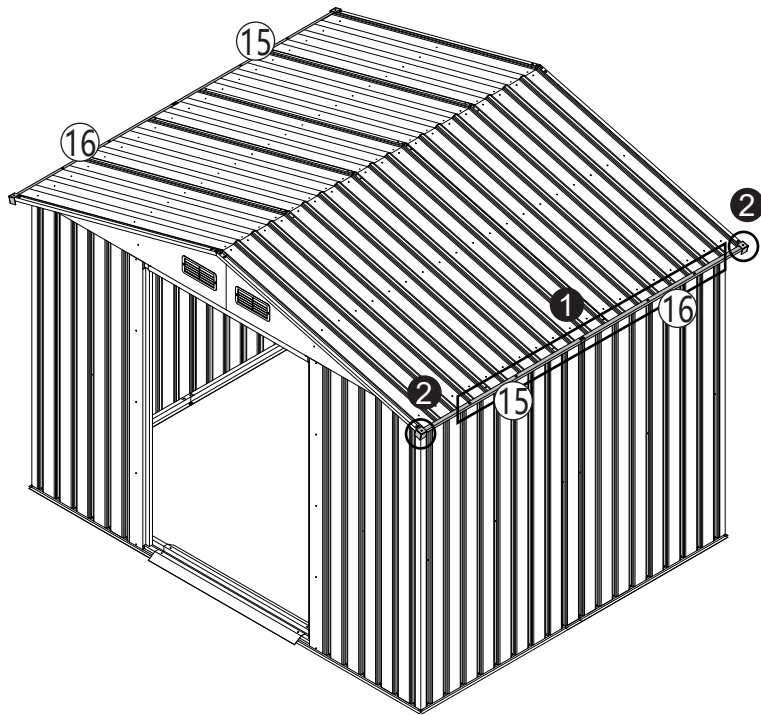

STEP 23

S2		X2	F1		X2
GC		X4			



PRODUCT ASSEMBLY

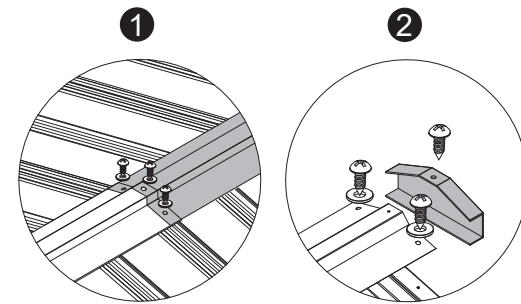
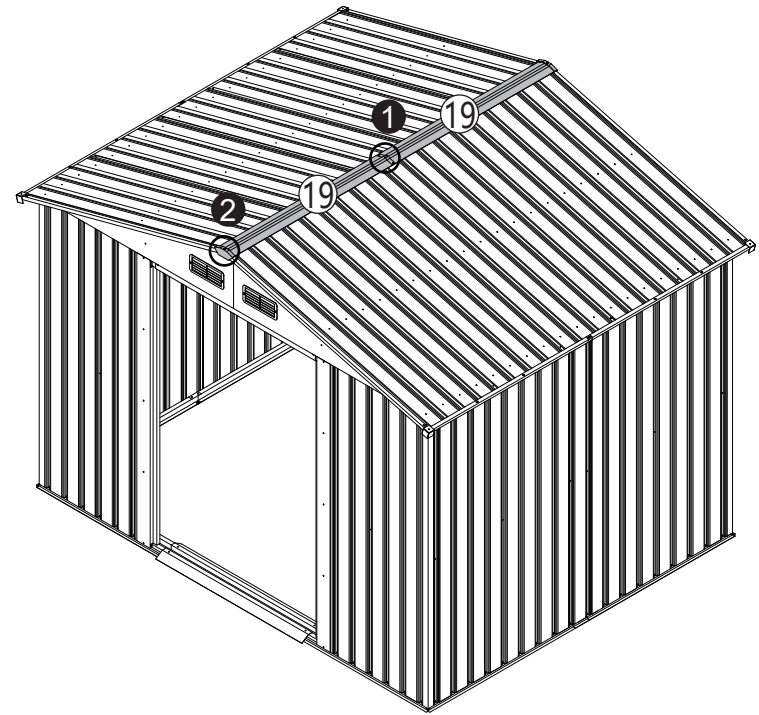

STEP 24

S2		X7	F1		X9
GE		X2			



PRODUCT ASSEMBLY

STEP 25

F2		X19	GD		X2
GB		X1			

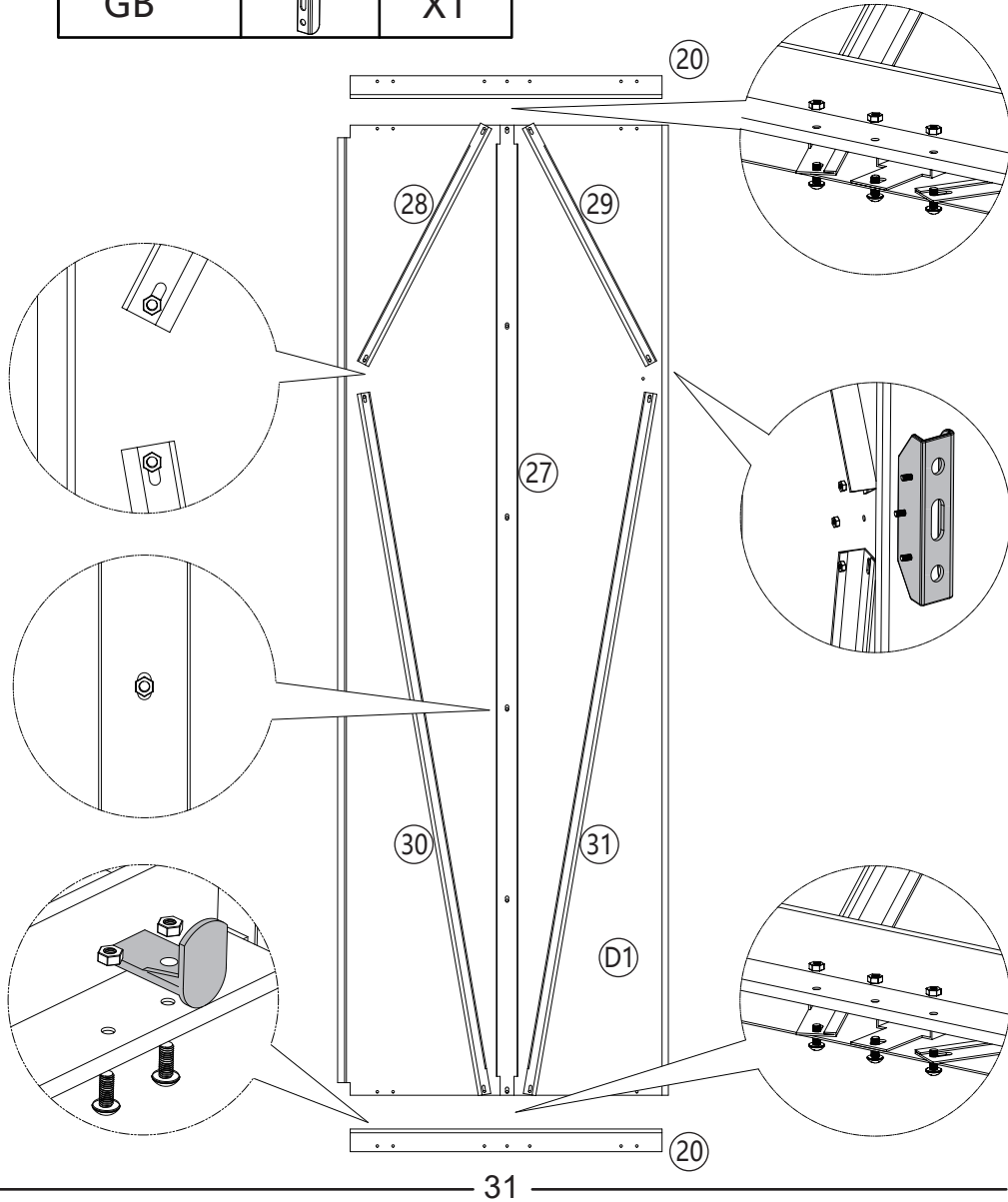

31

PRODUCT ASSEMBLY

STEP 26

F2		X19	GD		X2
			GB		X1

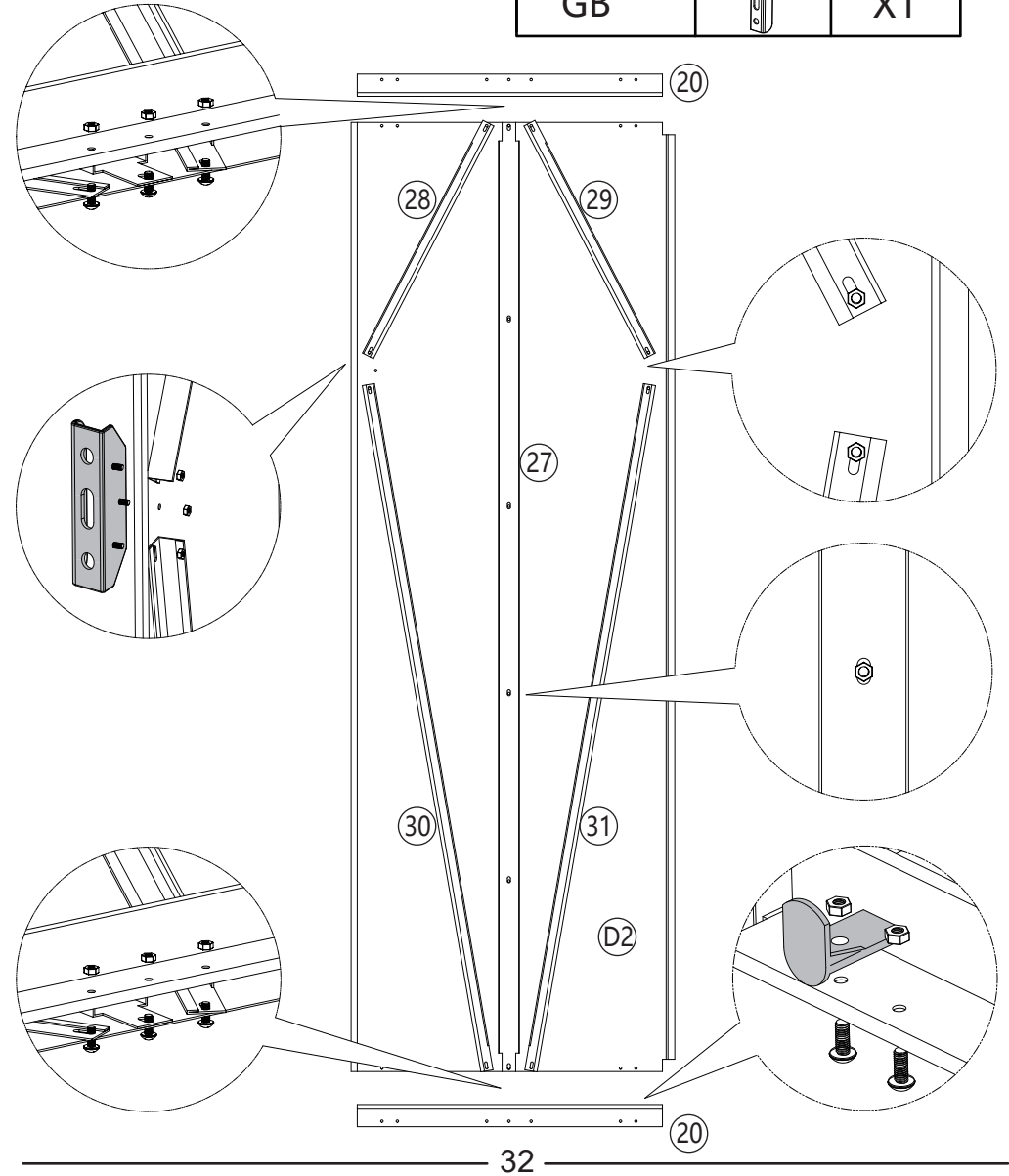

32

PRODUCT ASSEMBLY

STEP 27

F3		X8
----	---	----

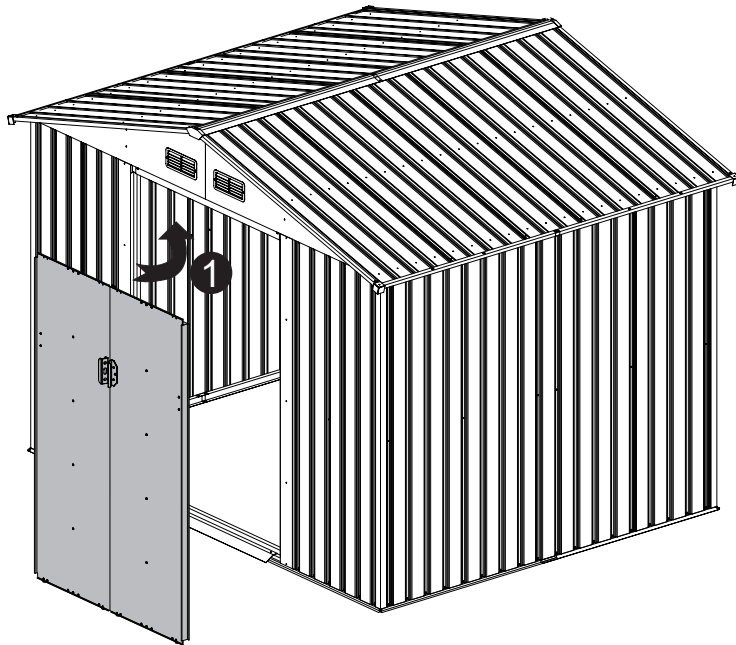
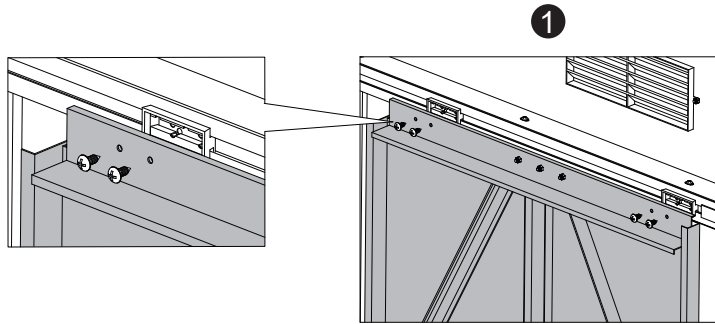

PRODUCT ASSEMBLY

STEP 28

S1	
----	---

