

## ASSEMBLY INSTRUCTION

### ASSEMBLY TIPS:

- 1.Remove hardware from box and sort by size.
- 2.Please check to see that all hardware and parts are present prior to start of assembly.
- 3.Please follow attached instructions in the same sequence as numbered to assure fast & easy assembly.









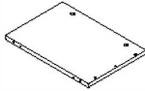
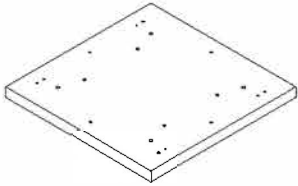
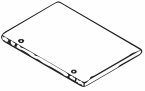
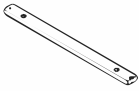

### Warning !

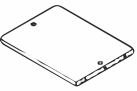
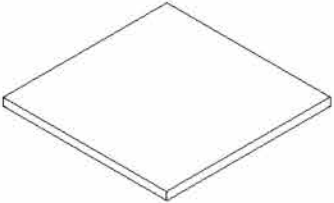

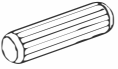

- 1.Don't attempt to repair or modify parts that are broken or defective.Please contact the store immediately.
- 2.This product is for home use only and not intended for commercial establishment.

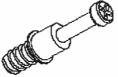
**ASSEMBLY TIME PER UNIT: 30 MINUTES**

### PARTS IDENTIFICATION:

|                      |   |      |                       |   |       |
|----------------------|---|------|-----------------------|---|-------|
| (A) LEFT SIDE PANEL  |    | 1 PC | (E) BOTTOM PANEL      |    | 1 PC  |
| (B) RIGHT SIDE PANEL |    | 1 PC | (F) LONG CROSS BRACE  |   | 2 PCS |
| (C) DOOR             |  | 1 PC | (G) SHORT CROSS BRACE |  | 2 PCS |
| (D) BACK PANEL       |  | 1 PC | (H) TOP PANEL         |  | 1 PC  |

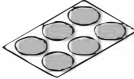
| Z  | HARDWARE PACKAGE              |   |        |    |                         |   |        |
|----|-------------------------------|---|--------|----|-------------------------|---|--------|
| NO | DESCRIPTION                   | FIGURE  | Q'TY   | NO | DESCRIPTION             | FIGURE  | Q'TY   |
| 1  | GLUE 40g                      |  | 1 PC   | 4  | CAM LOCK $\phi$ 15x12mm |  | 14 PCS |
| 2  | WOODEN DOWEL<br>$\phi$ 8x30mm |  | 20 PCS | 5  | BOLT $\phi$ 9.5x55mm    |  | 4 PCS  |
| 3  | CAM BOLT $\phi$ 7x35.5mm      |  | 14 PCS | 6  | SINGLE MAGNETIC CATCH   |  | 1 PC   |



| Z HARDWARE PACKAGE |                      |   |      |    |                     |   |       |
|--------------------|----------------------|---|------|----|---------------------|---|-------|
| NO                 | DESCRIPTION          | FIGURE  | Q'TY | NO | DESCRIPTION         | FIGURE  | Q'TY  |
| 7                  | FLEXIBLE DOOR DAMPER |  | 1 PC | 10 | CASTER              |  | 4 PCS |
| 8                  | FIXED DOOR DAMPER    |  | 1 PC | 11 | STICKER $\phi$ 20mm |  | 3 PCS |
| 9                  | SCREW FOR DOOR       |  | 1 PC |    |                     |   |       |

Z10 not included in blister packaging.

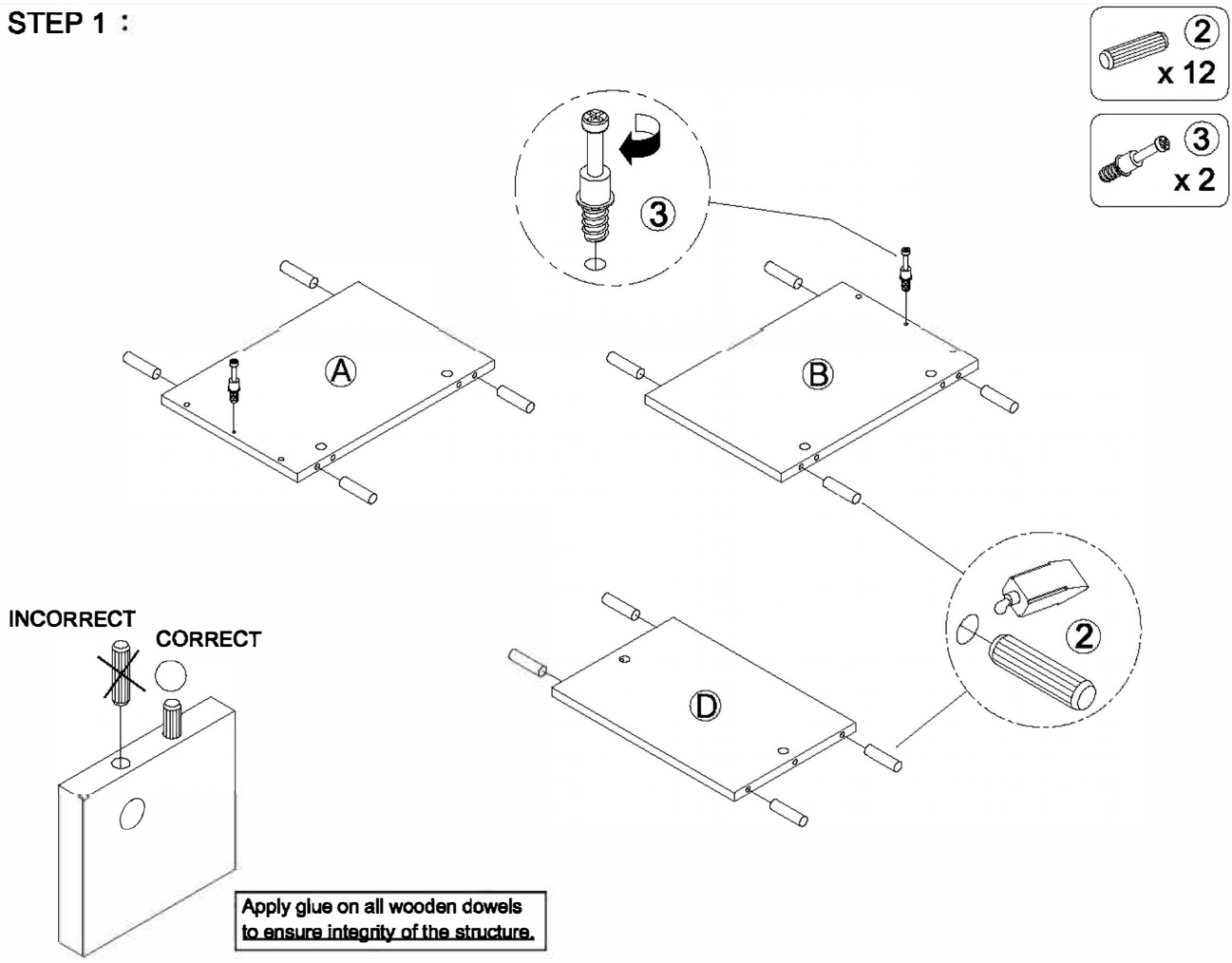
STEP 1 :



**STEP 2 :**

-  **4**  
x 2
-  **11**  
x 2

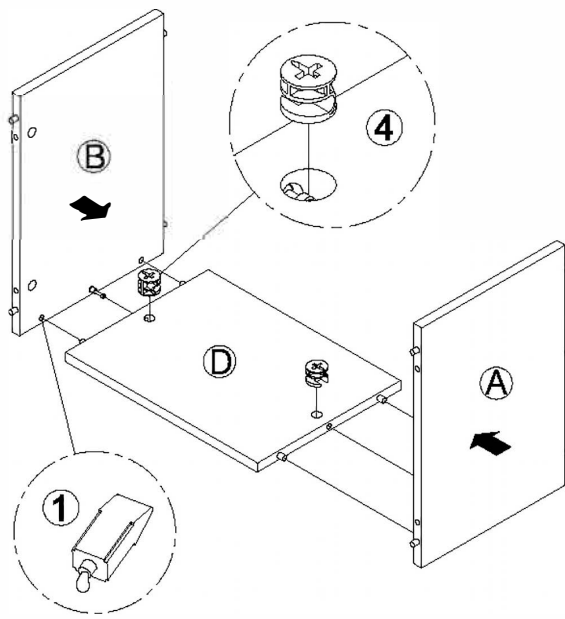

Apply glue on all wooden dowels to ensure integrity of the structure.

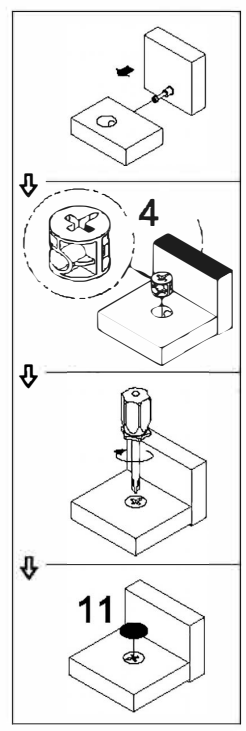

**STEP 3 :**

-  **3**  
x 8

-  **6**  
x 1

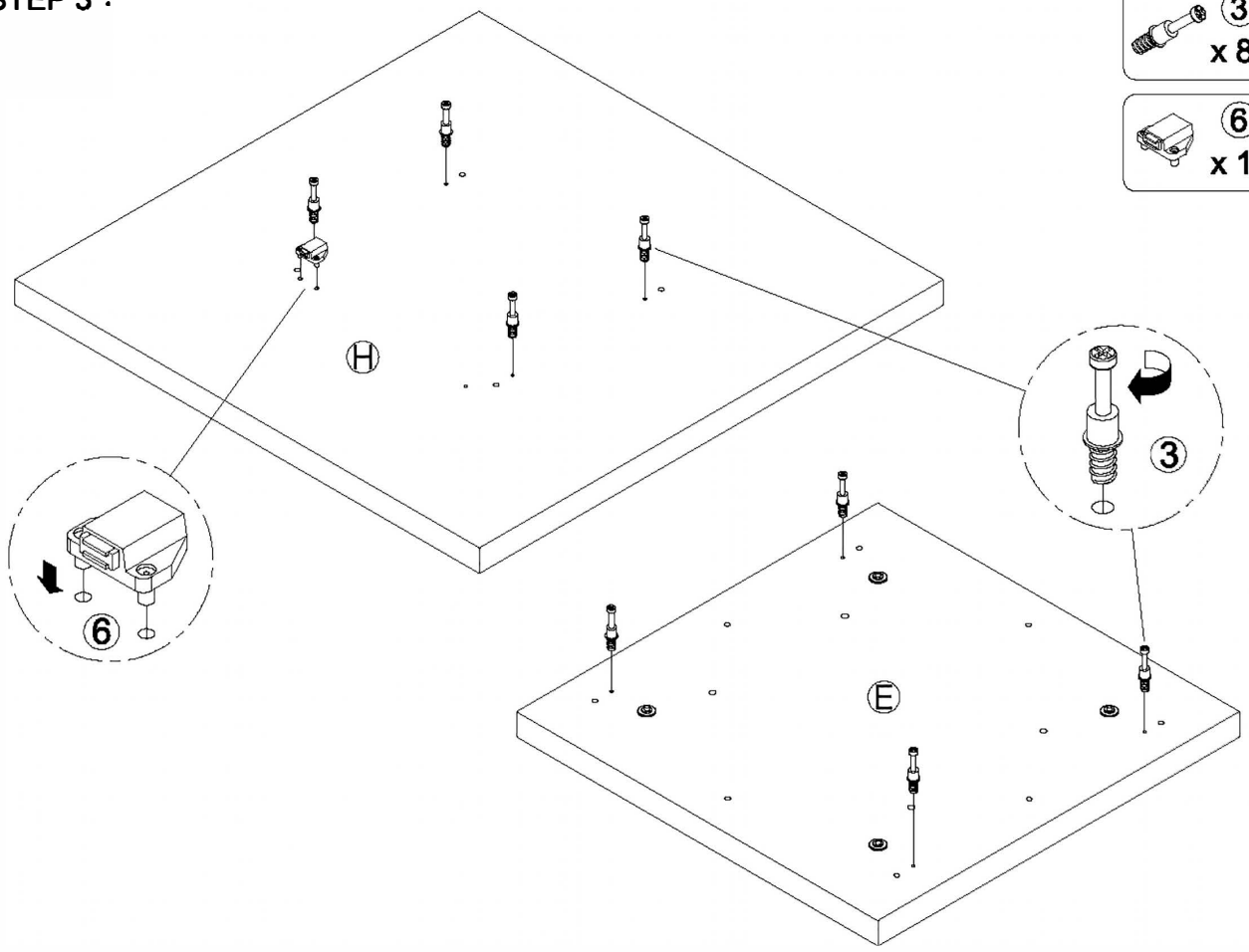

STEP 4 :

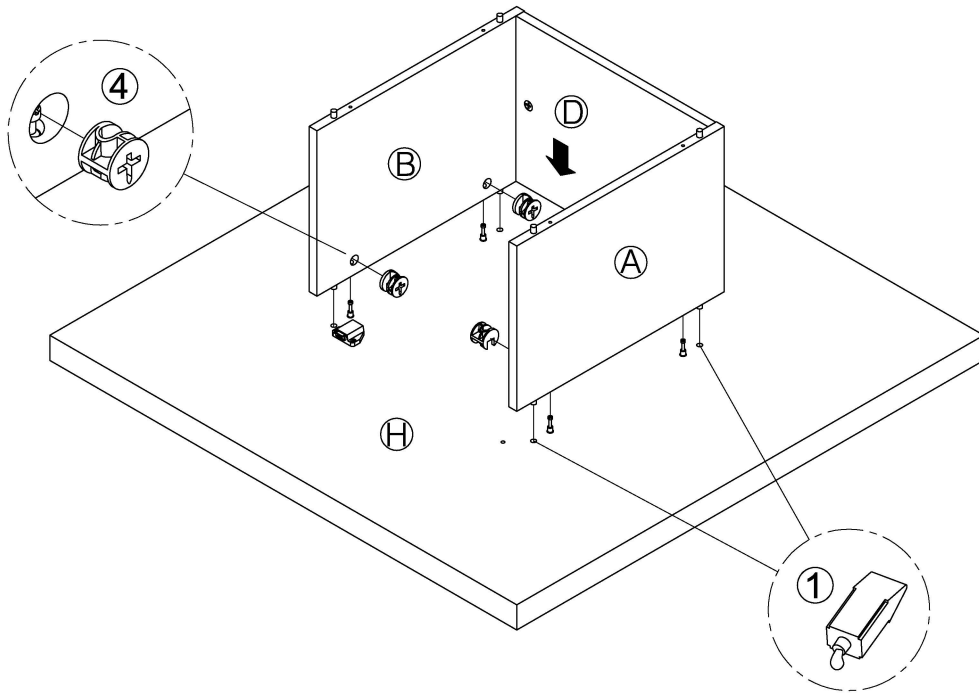
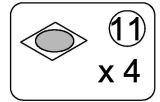
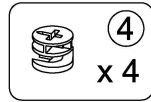

Apply glue on all wooden dowels to ensure integrity of the structure.

STEP 5 :

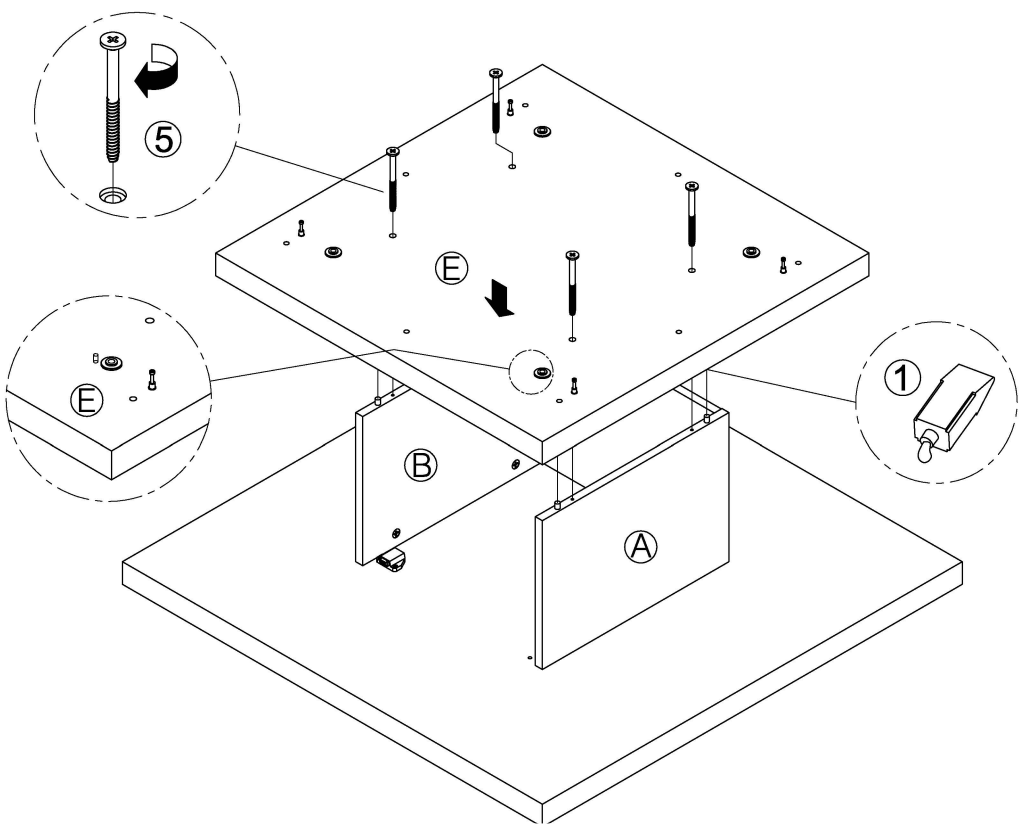

STEP 6:

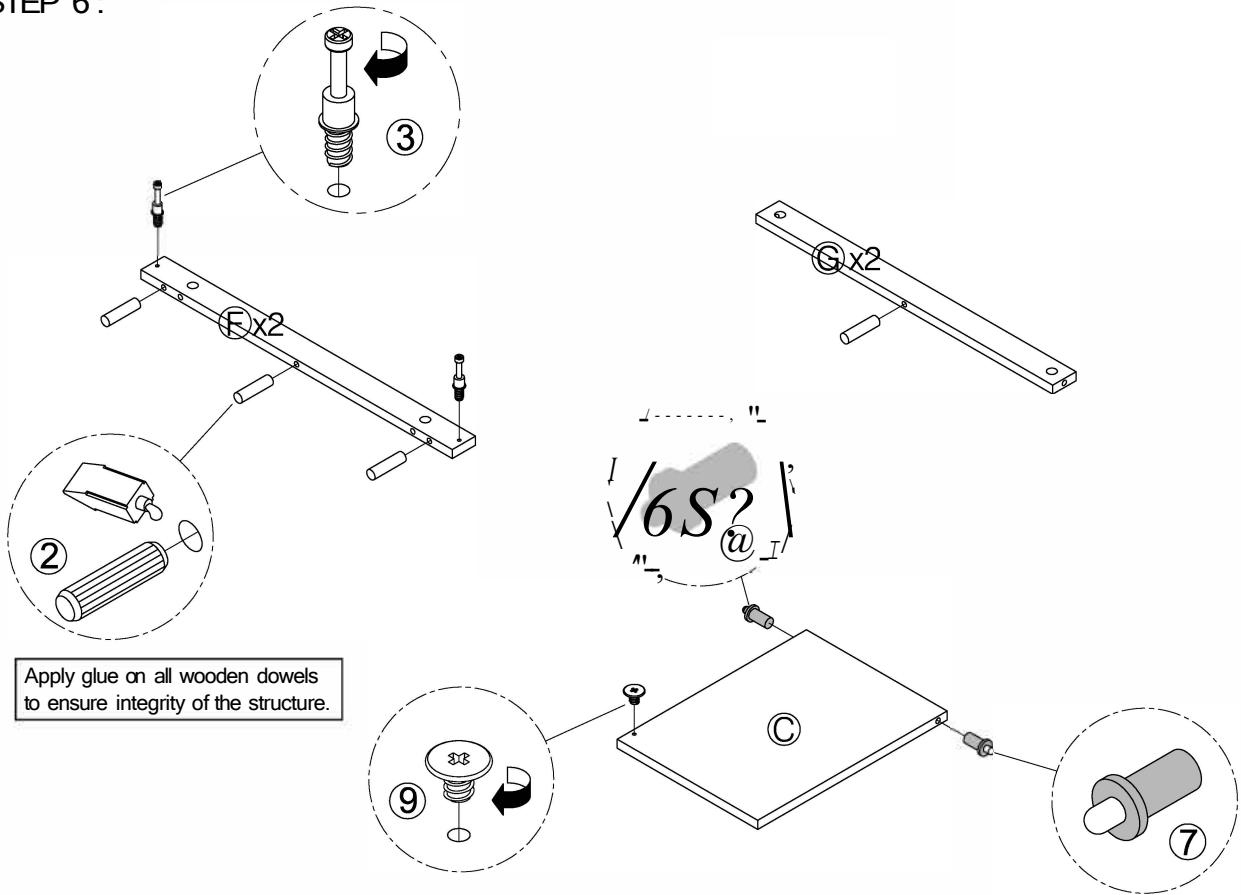

STEP 7:

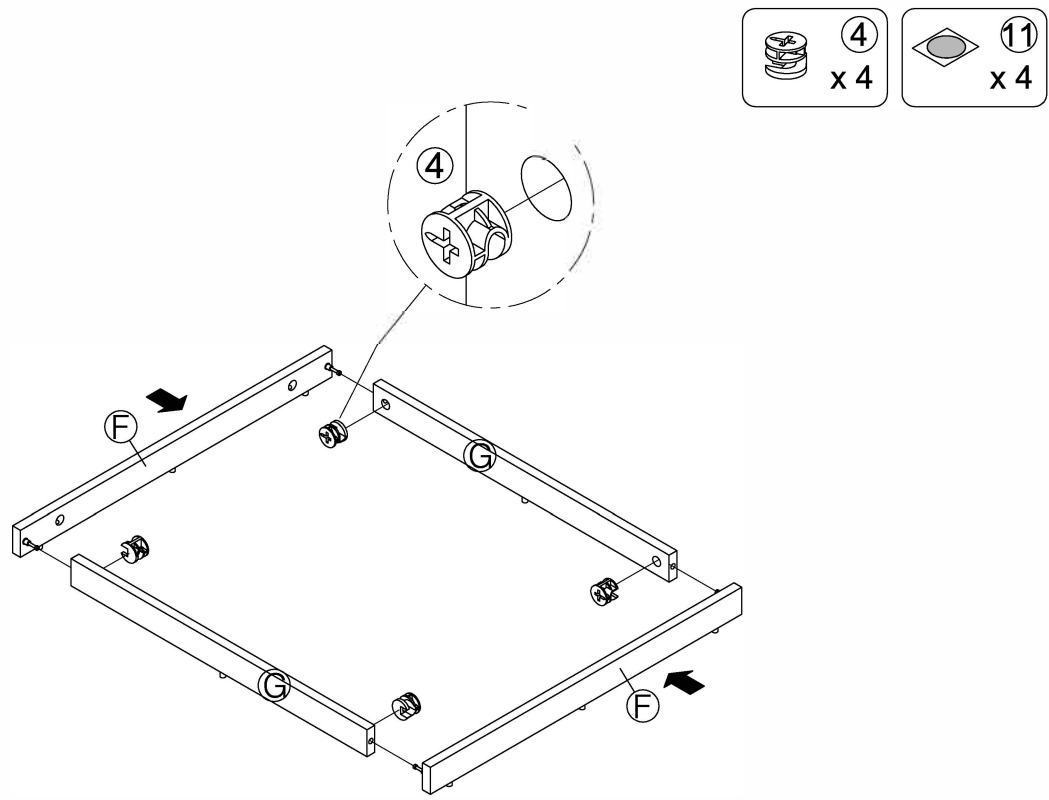

STEP 8:

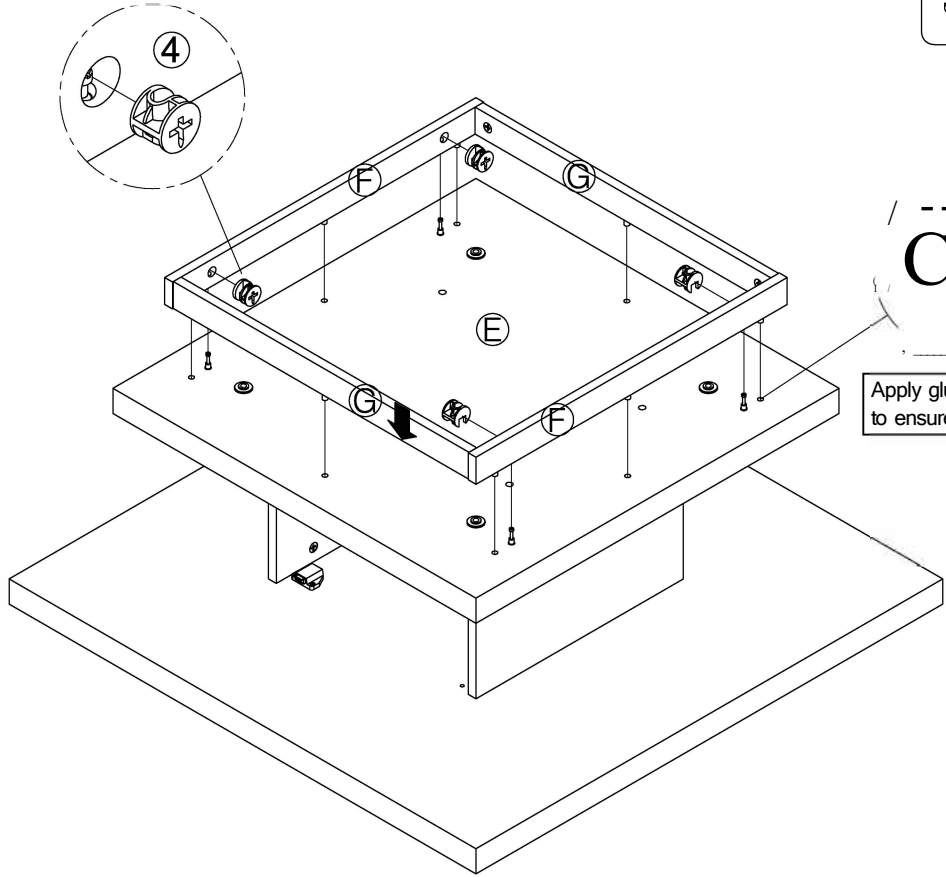
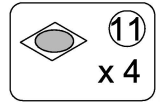
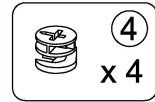

STEP 9:

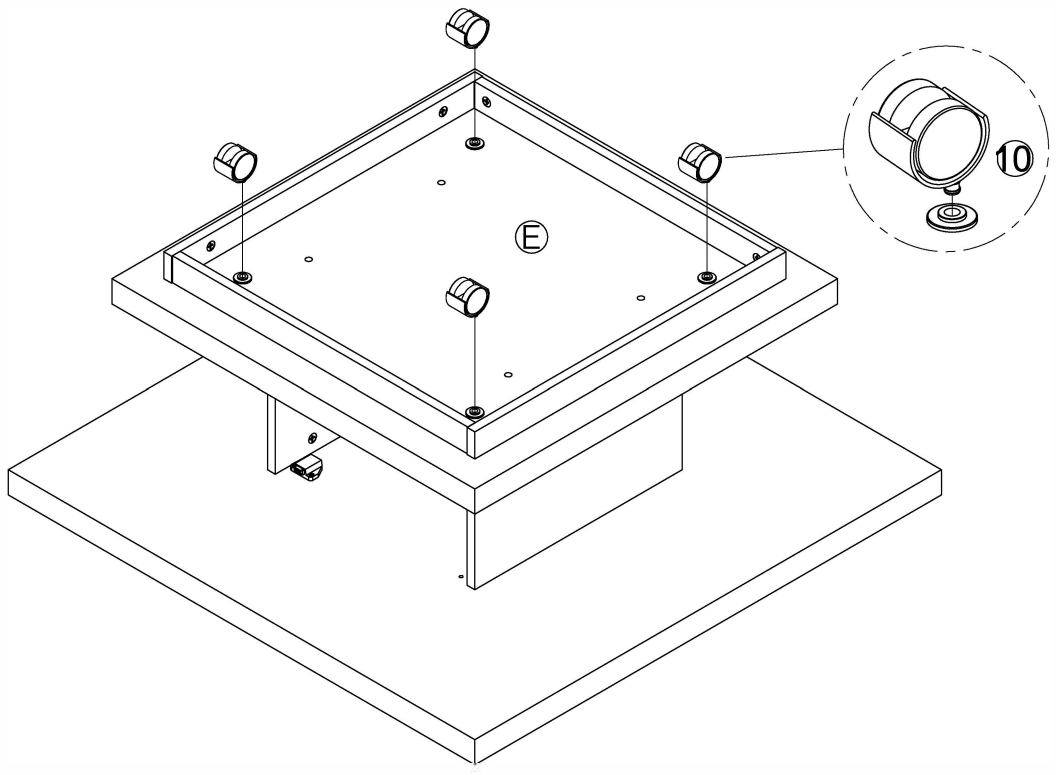
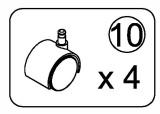

STEP 10 :

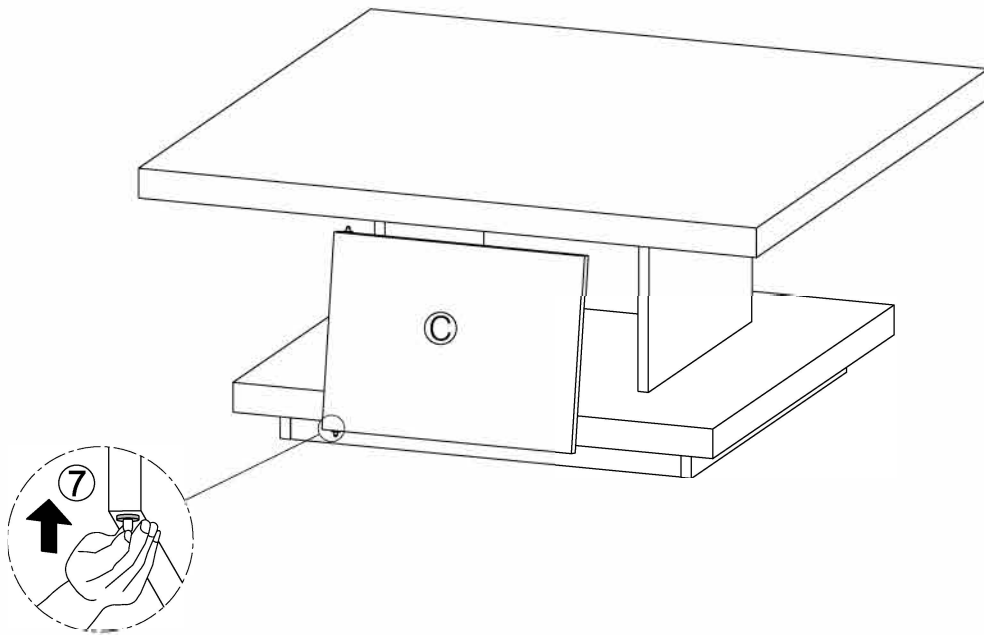

FINISH

