

ASSEMBLY INSTRUCTIONS

VANITY SET WHITE

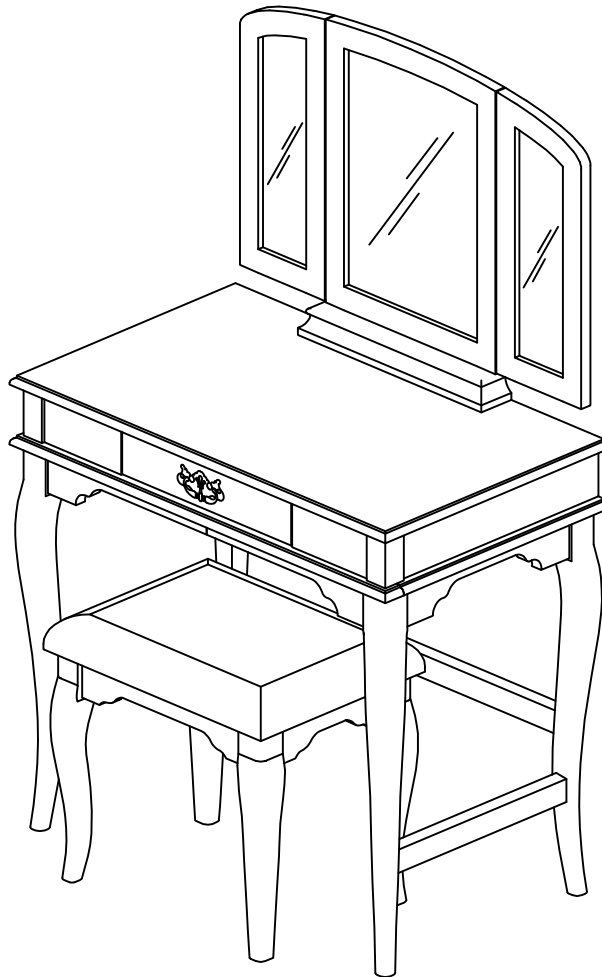

WE ARE HERE TO HELP!

WE DO OUR BEST TO INSURE THAT YOUR FURNITURE ARRIVES IN EXCELLENT CONDITION IN THE EVENT THAT A PART IS DAMAGED OR MISSING.

IF YOU NEED ASSISTANCE WITH ASSEMBLY OR REPLACEMENT PARTS, PLEASE CALL CUSTOMER SERVICE, PRIOR TO RETURNING THE ITEM TO THE STORE.

INSTRUCTIONS ON YOUR NEWLY PURCHASED FURNITURE.







IMPORTANT:
PLEASE READ ALL INSTRUCTIONS IN THIS BOOKLET BEFORE STARTING ASSEMBLY.

MADE IN VIETNAM

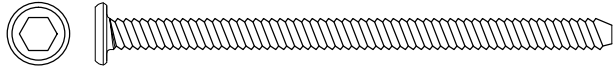
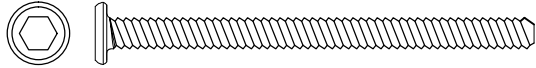
HARDWARE PACKAGE COUNT

OPEN HARDWARE PACKAGE ON A FLAT SURFACE COVERED WITH NEWSPAPER. COUNT EACH PIECE OF HARDWARE TO MATCH THE QUALITY NUMBER IN THE HARDWARE LIST COLUMN CALL CUSTOMER SERVICE IF ANY OF THE PARTS ARE MISSING. FOLLOW THE LETTER IDENTIFICATION WHEN READING THE ASSEMBLY DRAWING "A" THROUGH "H"

HARDWARE IDENTIFICATION

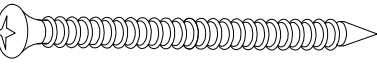
SYMBOL	GRAPHICS	DESCRIPTION	QTY
A	 $\varnothing 1/4" \times L. 2-1/2"$	LONG BOLT	8
B	 $\varnothing 1/4" \times L. 2-1/8"$	MEDIUM BOLT	8
C	 $\varnothing 1/4" \times L. 1-1/2"$	SHORT BOLT	4
D		SPRING WASHER	20
E		FLAT WASHER	20
F	 $\varnothing 8 \times 25 \text{mm}$	WOOD DOWEL	2
G		ALLEN WRENCH	1
H	 $\varnothing 4 \times L. 45 \text{mm}$	ROUND HEAD SCREW	6

ALL PARTS ARE LABELED WITH STICKERS MATCHING THE PART IDENTIFICATION NUMBERS LISTED ON PAGE 3.

IMPORTANT

PLEASE USE ALL THE HARDWARE MENTIONED ABOVE
THEY WILL ASSURE THE ITEM STABILITY AND SAFETY.

TOOLS REQUIRED

A STANDARD PHILIPS HEAD SCREWDRIVER (NOT PROVIDED) AND AN ALLEN WRENCH " G" (PROVIDED) ARE REQUIRED TO ASSEMBLE THIS UNIT. USE A PLASTIC HEAD Mallet, NOT PROVIDED, TO TAP IN STRETCHERS OR OTHER COMPONENTS.

PART IDENTIFICATION:

PART NUMBER	DESCRIPTION	QTY
1	TABLE-TOP	01
2	TABLE- RIGHT -BACK LEG	01
3	TABLE- LEFT- BACK LEG	01
4	TABLE- LEFT- FRONT LEG	01
5	TABLE- RIGHT- FRONT LEG	01
6	TABLE- SIDE CROSSBAR	02
7	TABLE- BACK CROSSBAR	01
8	MIRROR-CENTER	01
9	MIRROR-LEFT	01
10	MIRROR-RIGHT	01
11	STOOL- CUSHION FRAME	01
12	STOOL-LEG	04

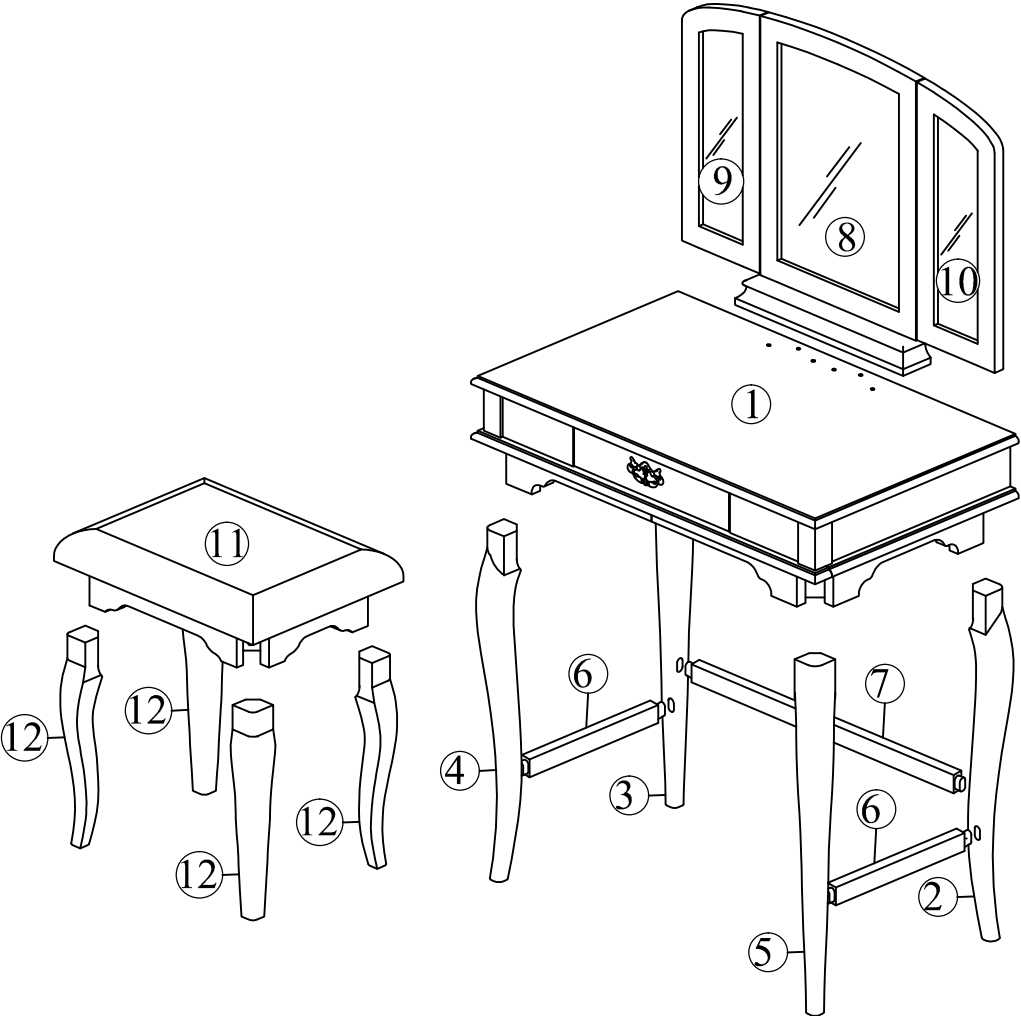

STEP 1:

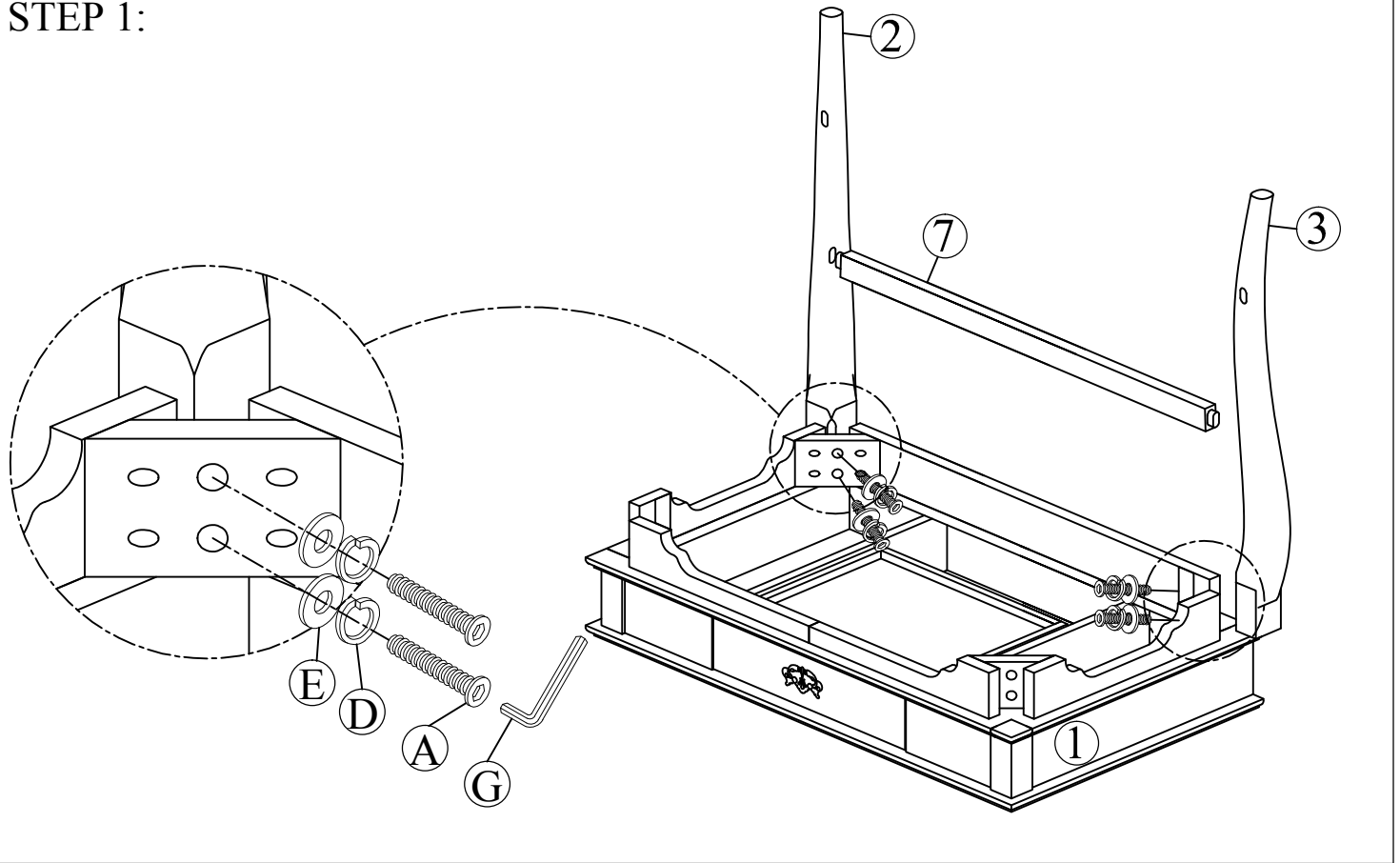

STEP 2:

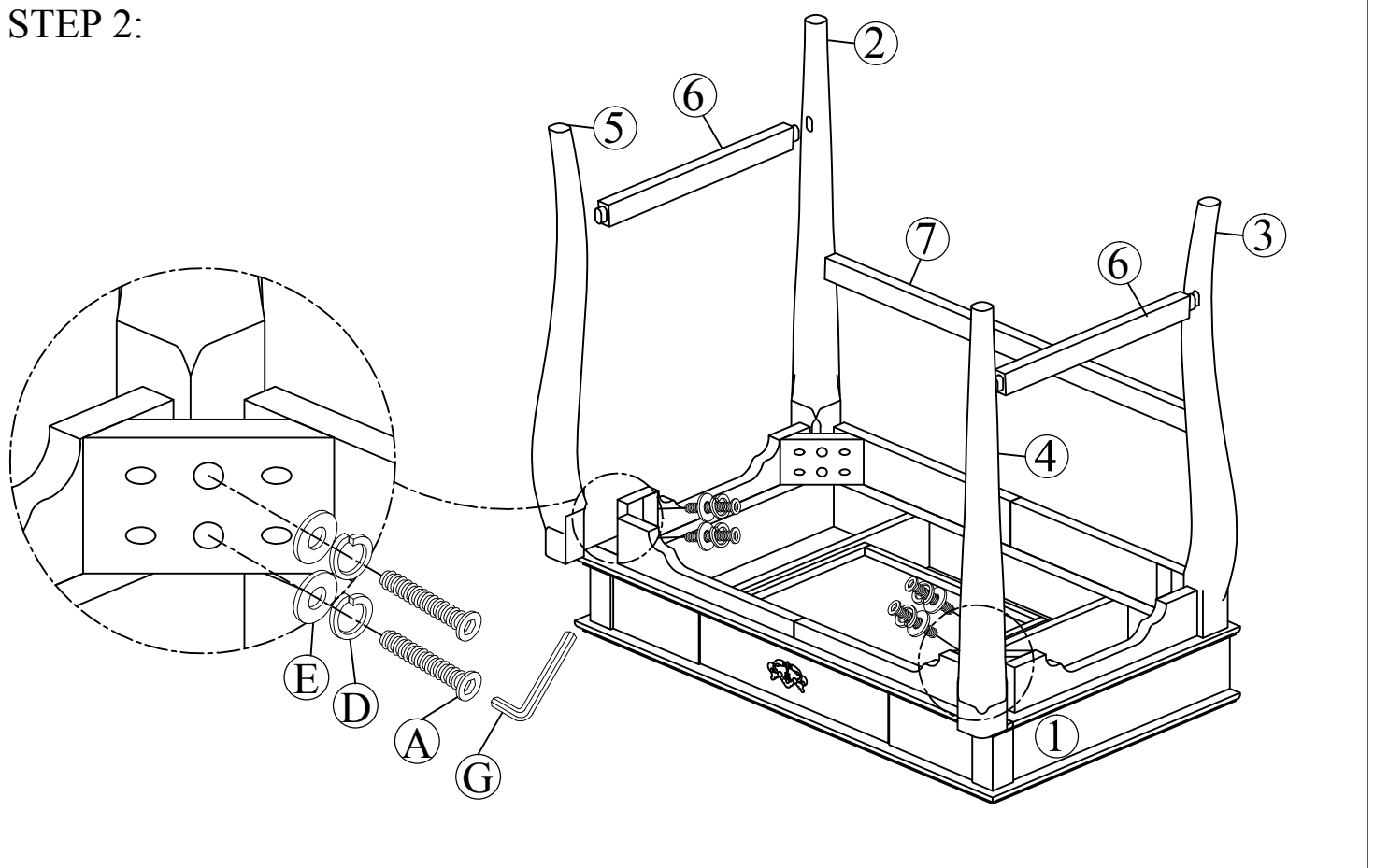

STEP 3:

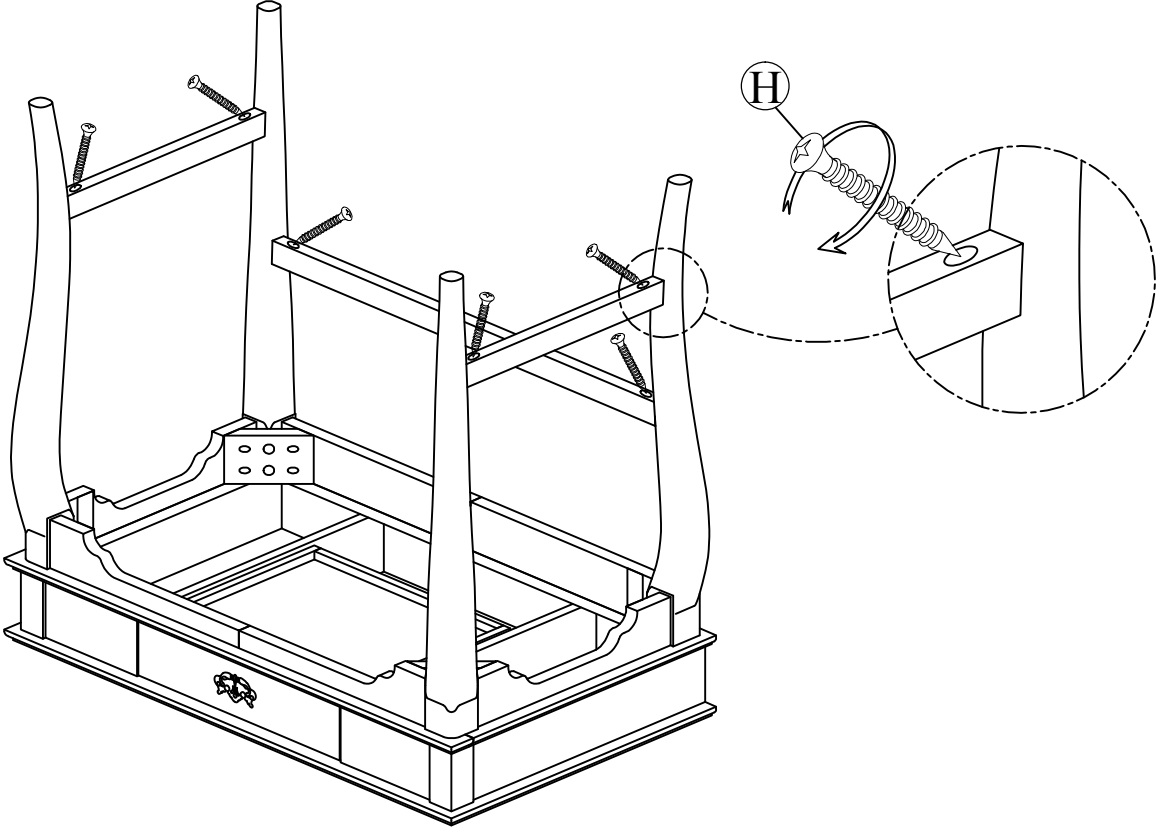

STEP 4:

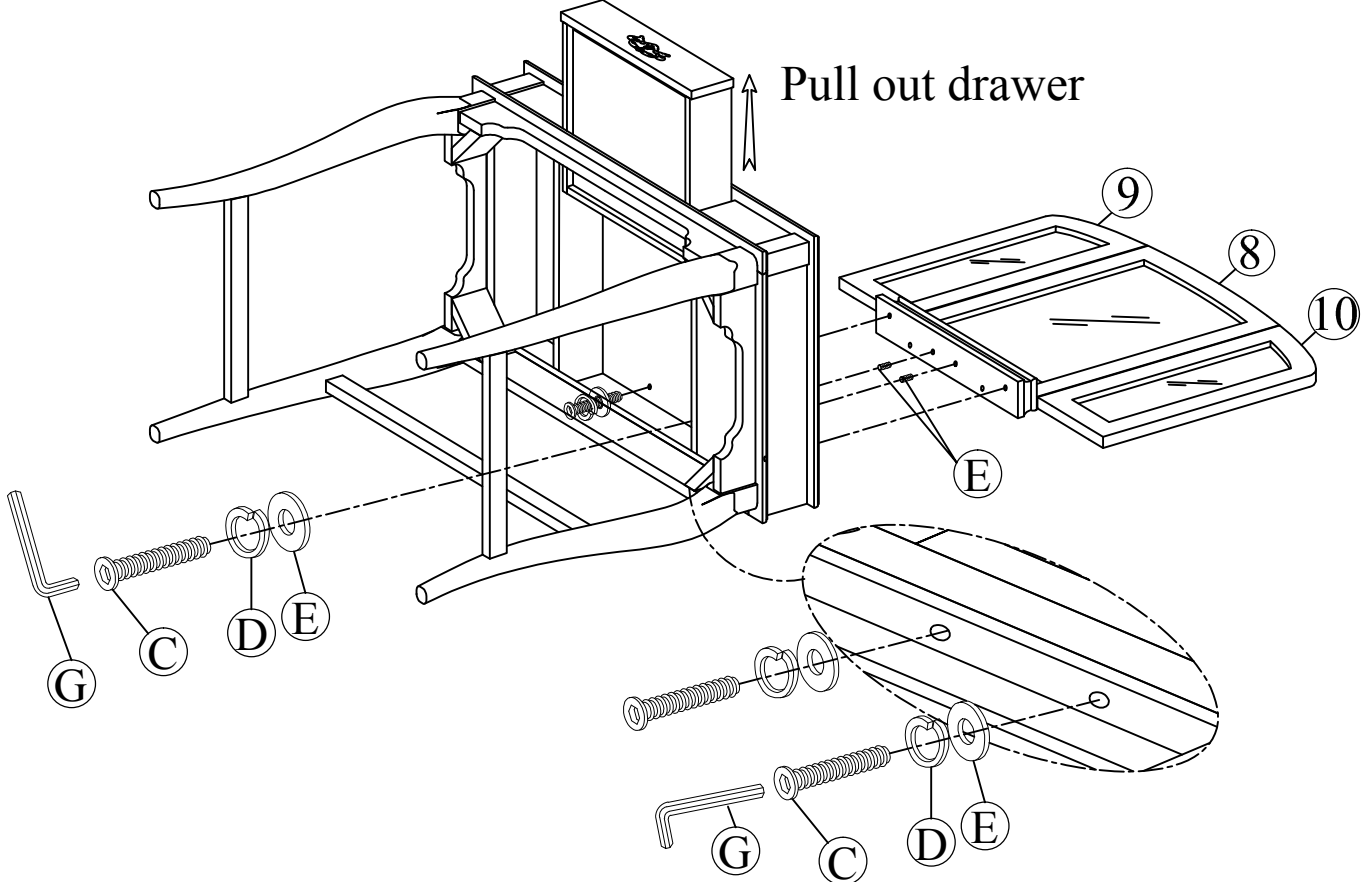

STEP 5:

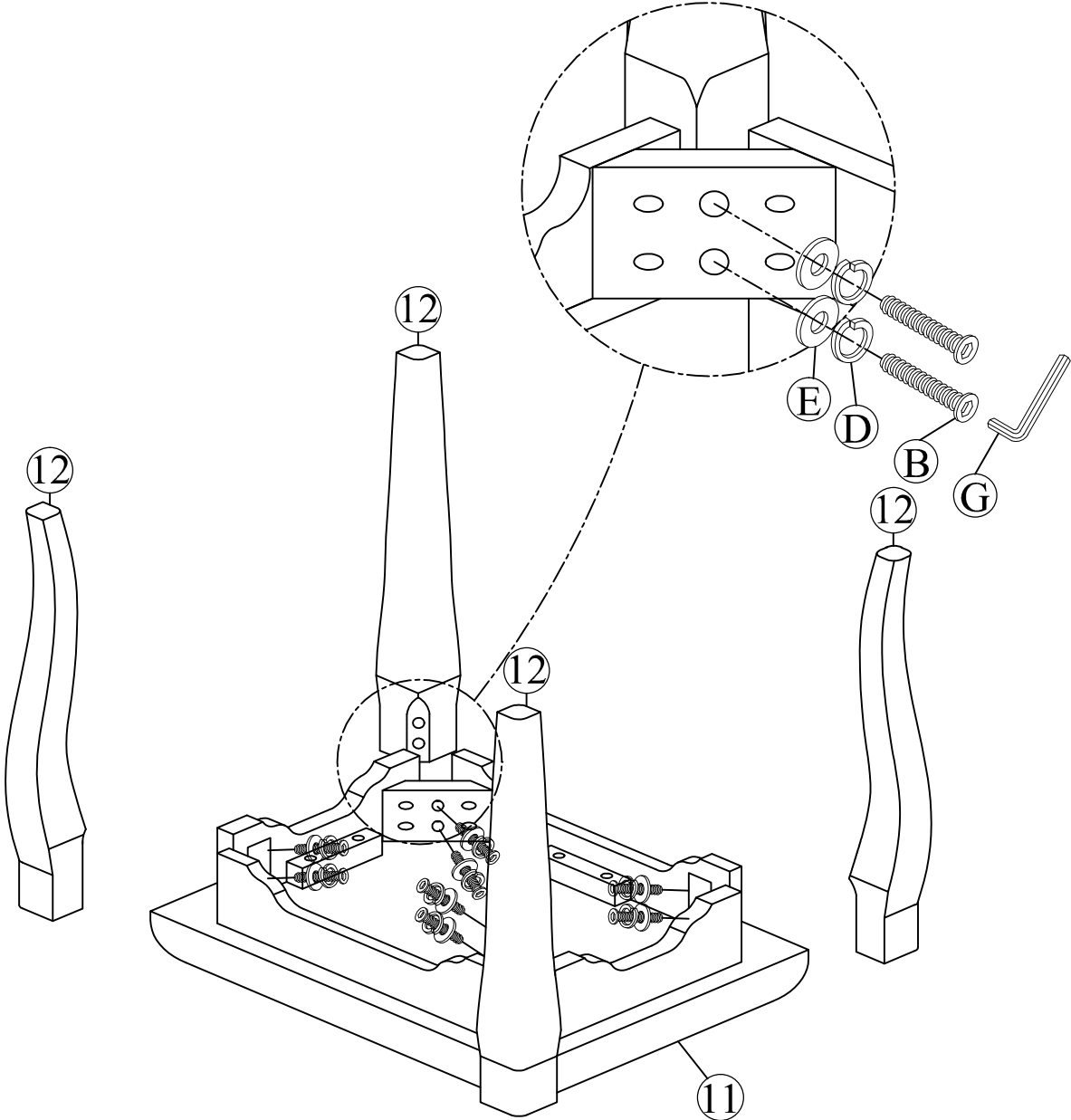

COMPLETED ASSEMBLY

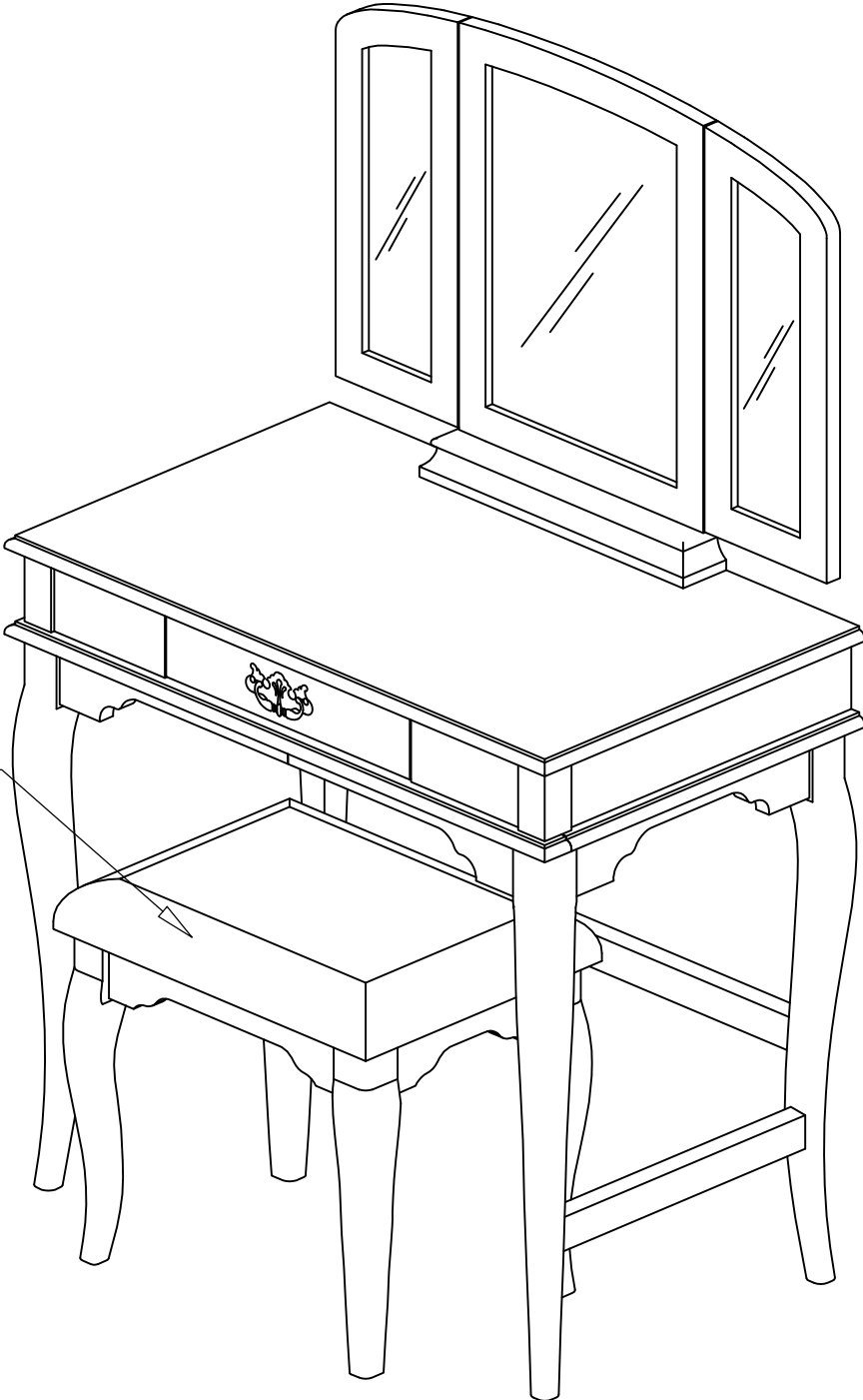

**WEIGHT LIMIT
275 LBS**