

ASSEMBLY INSTRUCTIONS

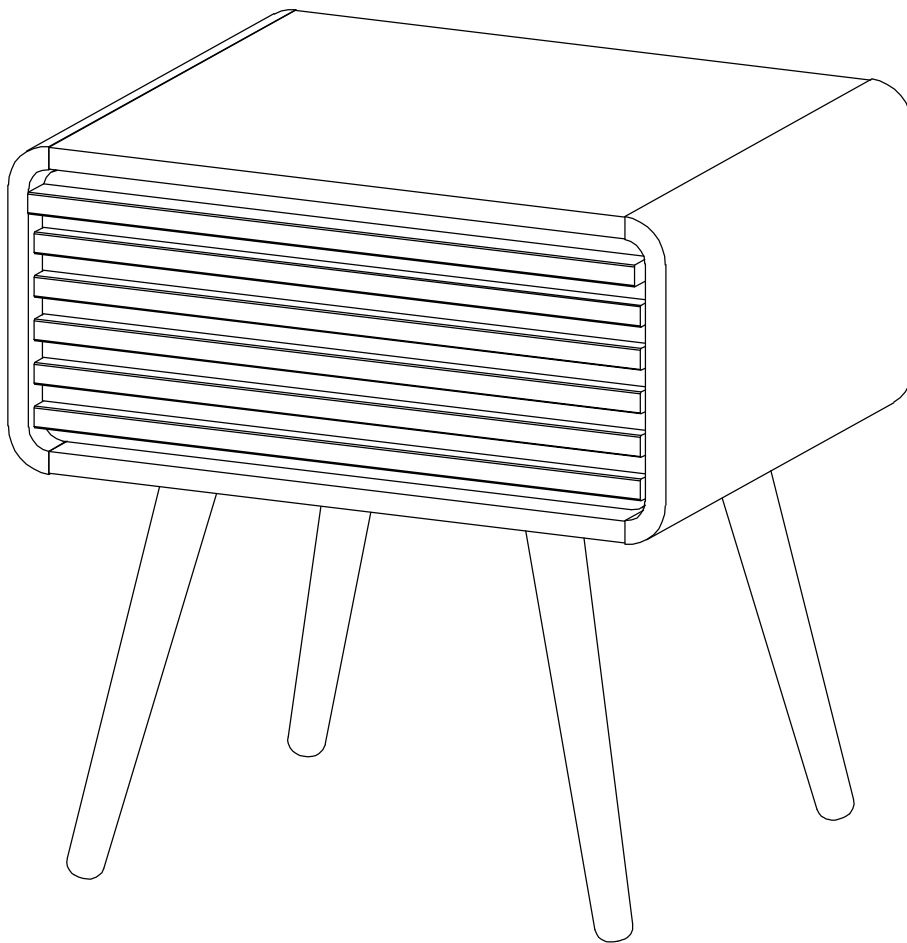

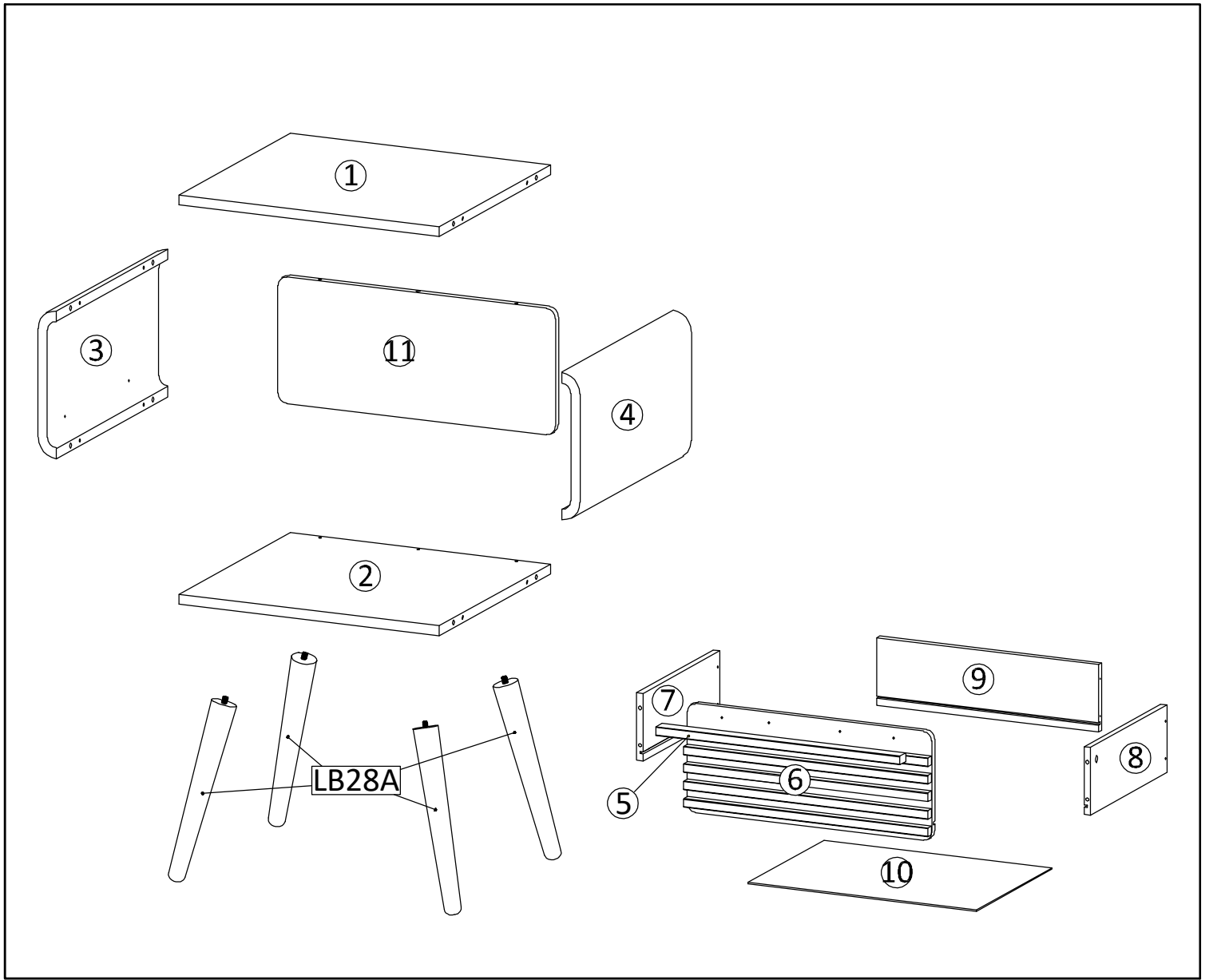

Hardware			
A	x 10	B	x 2
Ø6 x 35 mm (LONG)		Ø6 x 32 mm (SHORT)	
C	x 8	D	x 4
Ø15 mm (BIG)		Ø12 mm (SMALL)	
E	x 8	F	x 6
Ø8 x 30 mm (BIG)		Ø6 x 30 mm (SMALL)	
G	x 4	H	x 24
I	x 6	J	x 4
K	x 1	RM30A	x 1
PM1	x 4		



SET-UP TIME : 60 MINUTES



NUMBER OF PERSONS : 02



TOOLS :

1

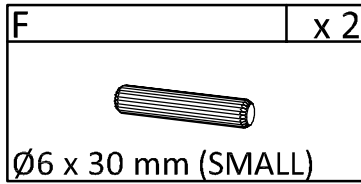
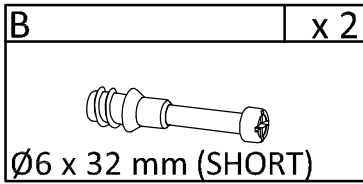
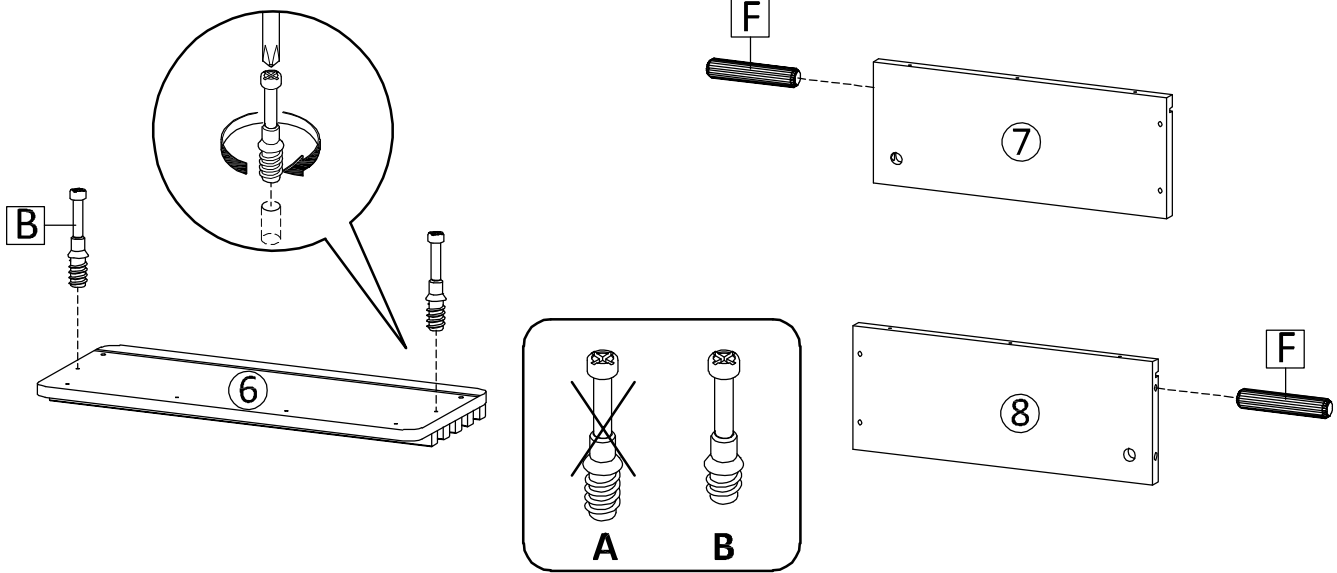

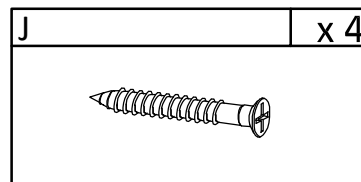
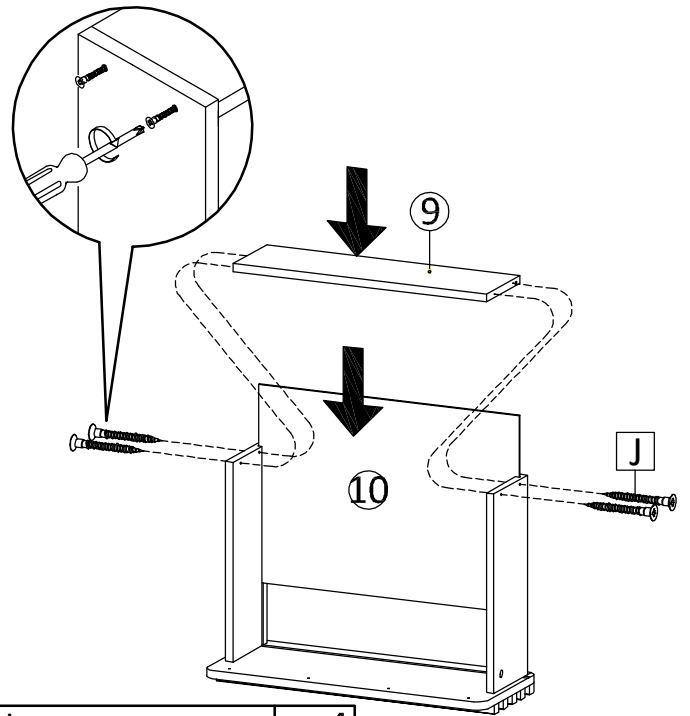
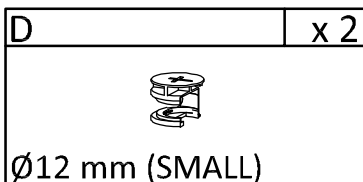
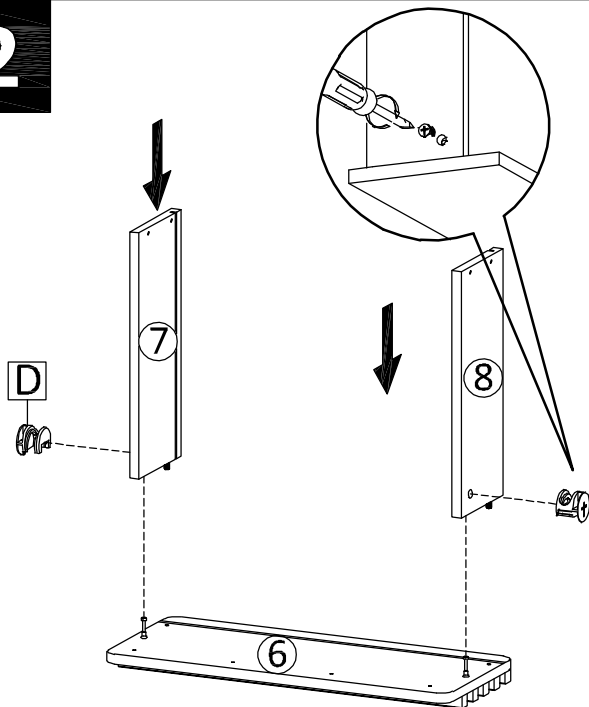

2



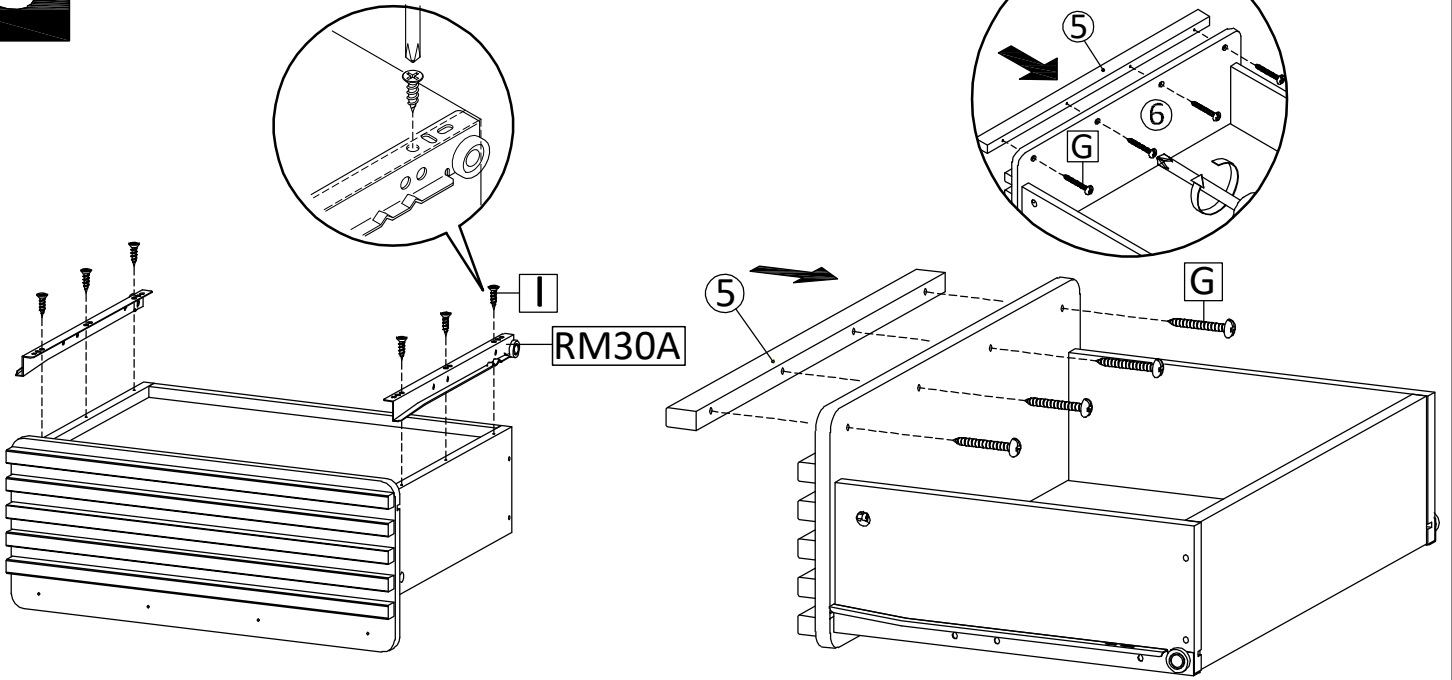

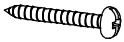
3

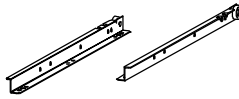

G	x 4	I	x 6	RM30A	x 1
					

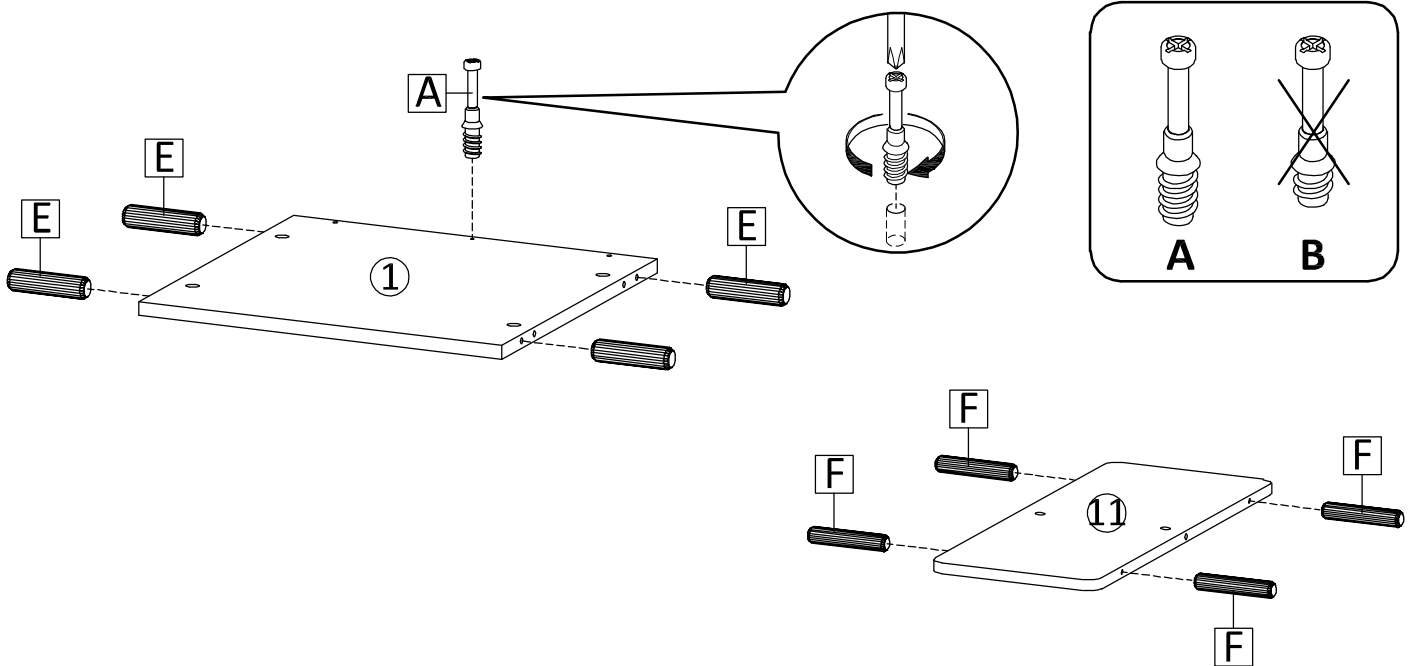
4

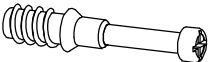

A	x 1	E	x 4	F	x 4
					
Ø6 x 35 mm (LONG)		Ø8 x 30 mm (BIG)		Ø6 x 30 mm (SMALL)	

5

Attention (Leg Mitres) Assembly Position

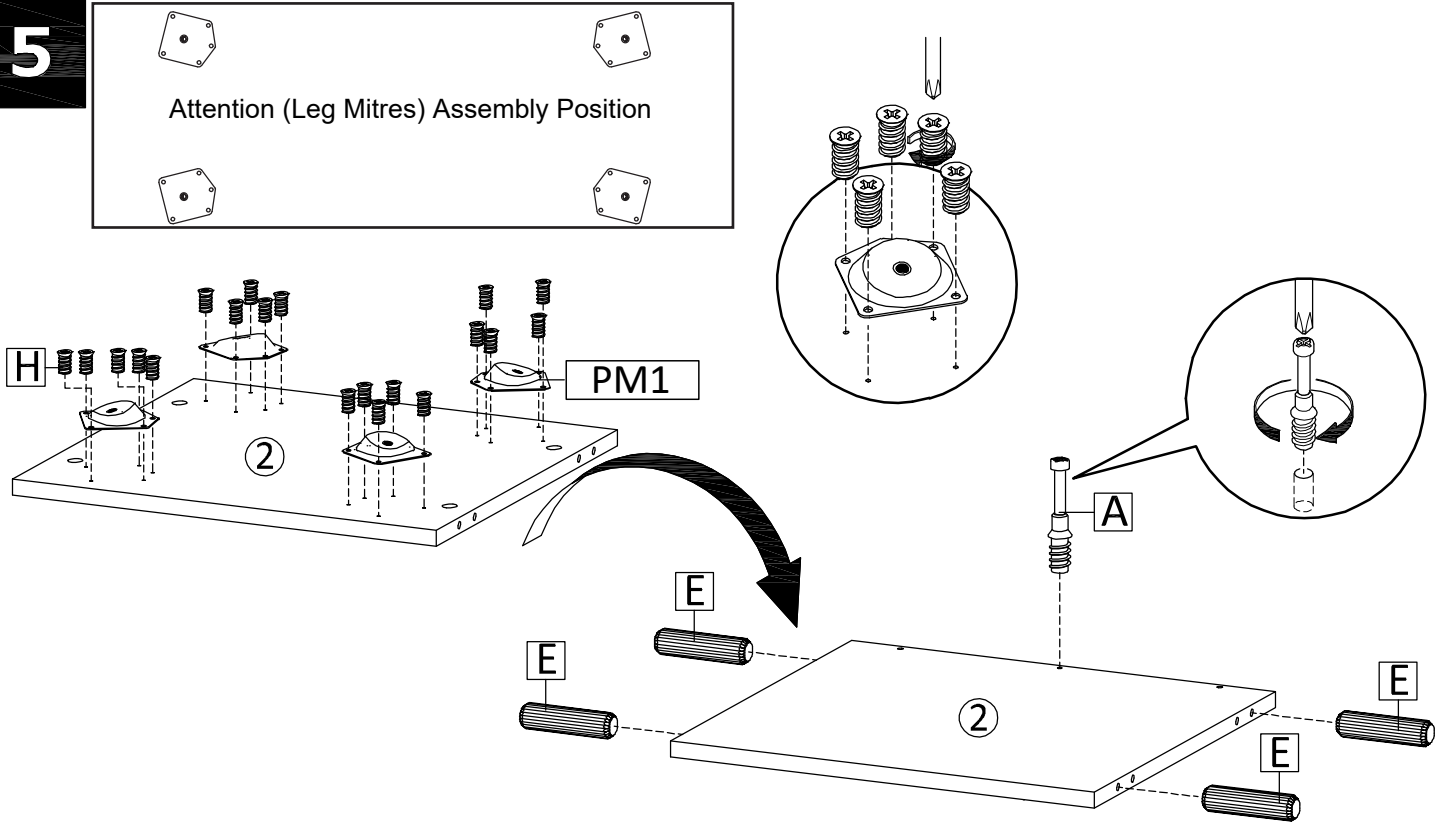

A	x 1	E	x 4	H	x 20	PM1	x 4
<p>Ø6 x 35 mm (LONG)</p>		<p>Ø8 x 30 mm (BIG)</p>					

6

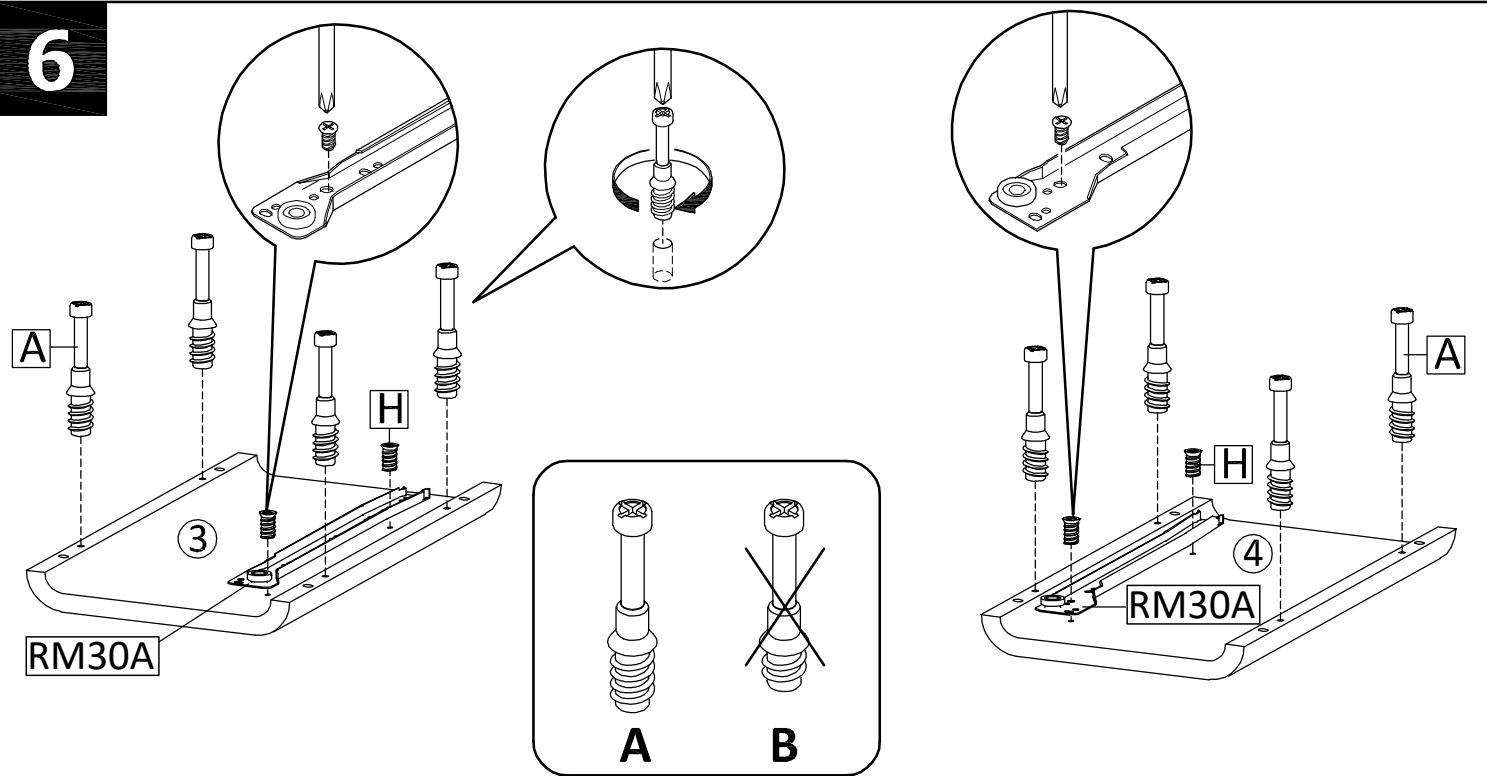

A	x 8	H	x 4	RM30A	x 1
<p>Ø6 x 35 mm (LONG)</p>					

7

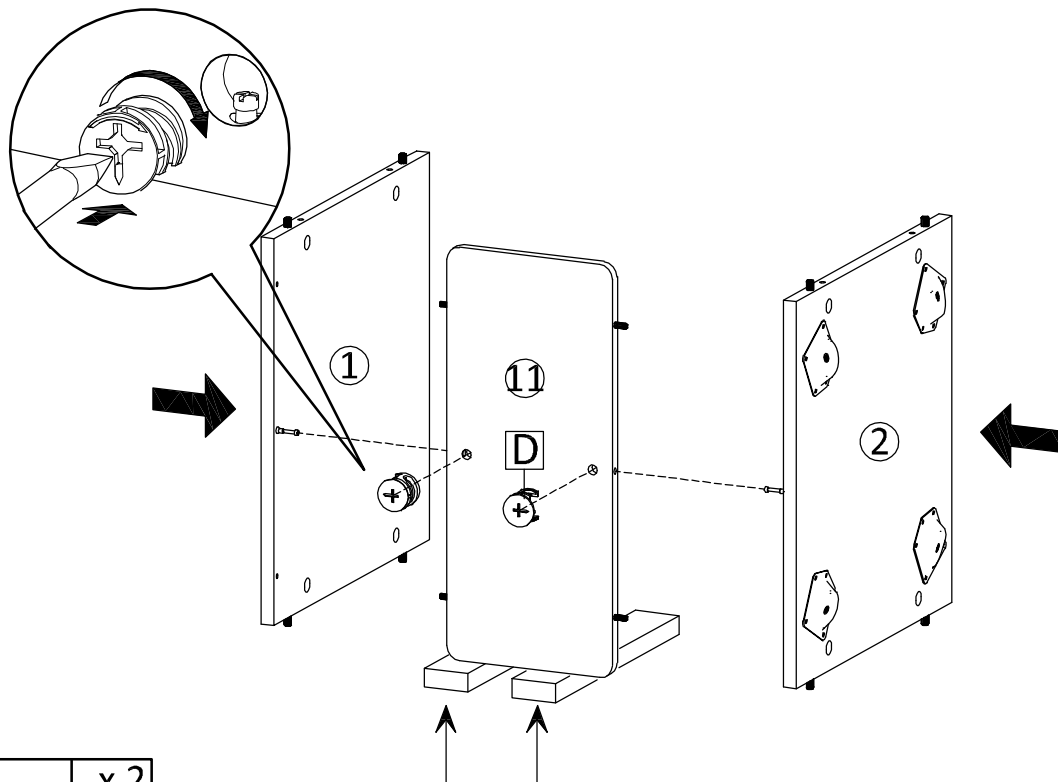

D	x 2
Ø12 mm (SMALL)	

USE EPS FROM THE PACKAGING MATERIAL

8

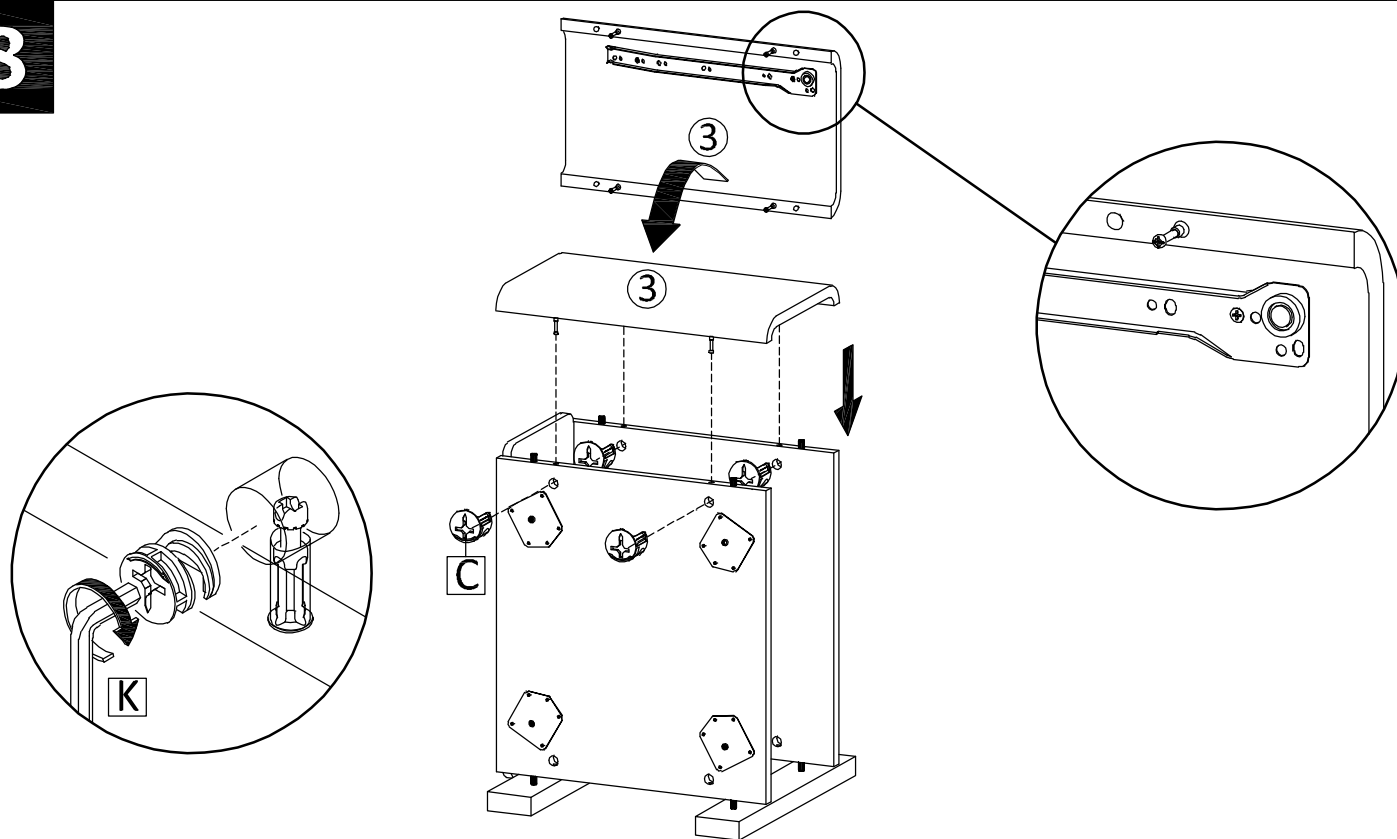



C	x 4
Ø15 mm (BIG)	

K	x 1

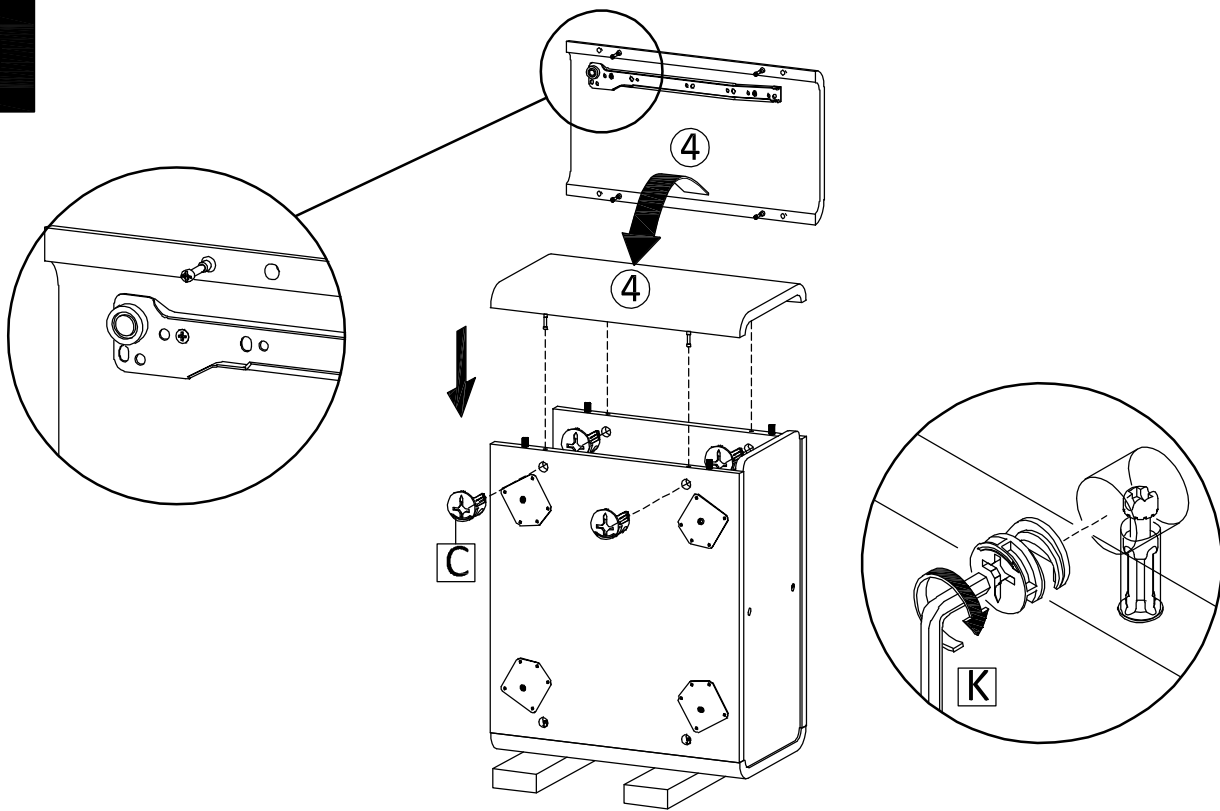
9



C	x 4	K	
			
Ø15 mm (BIG)			

10

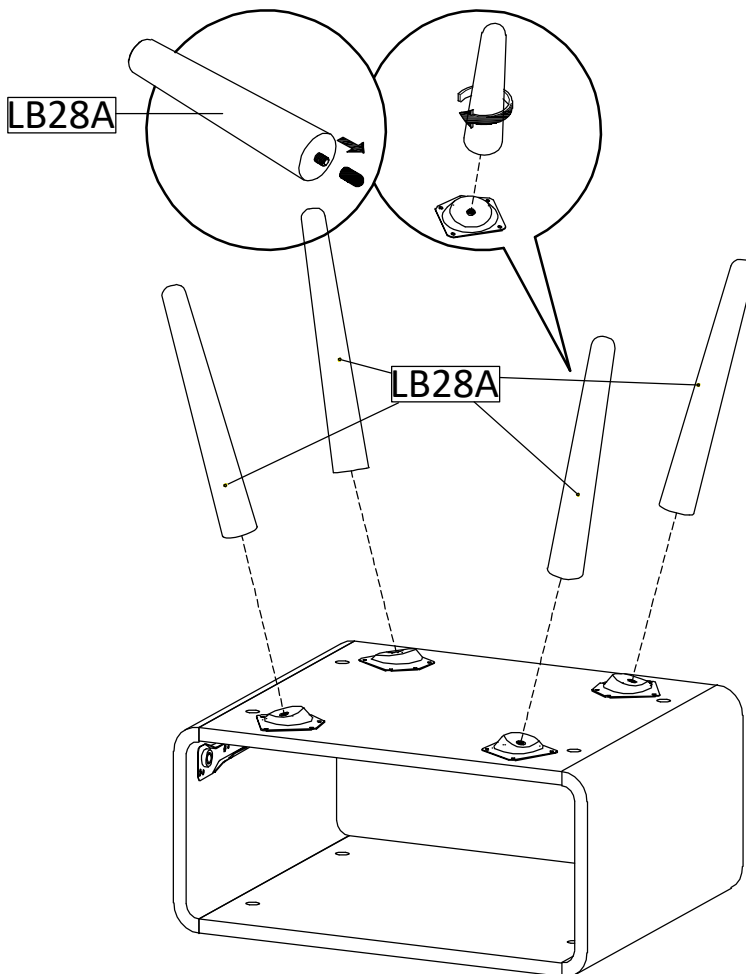

11

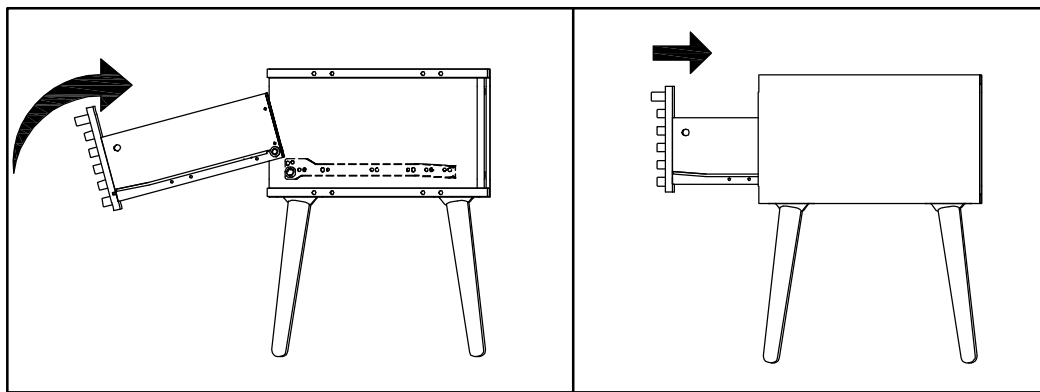
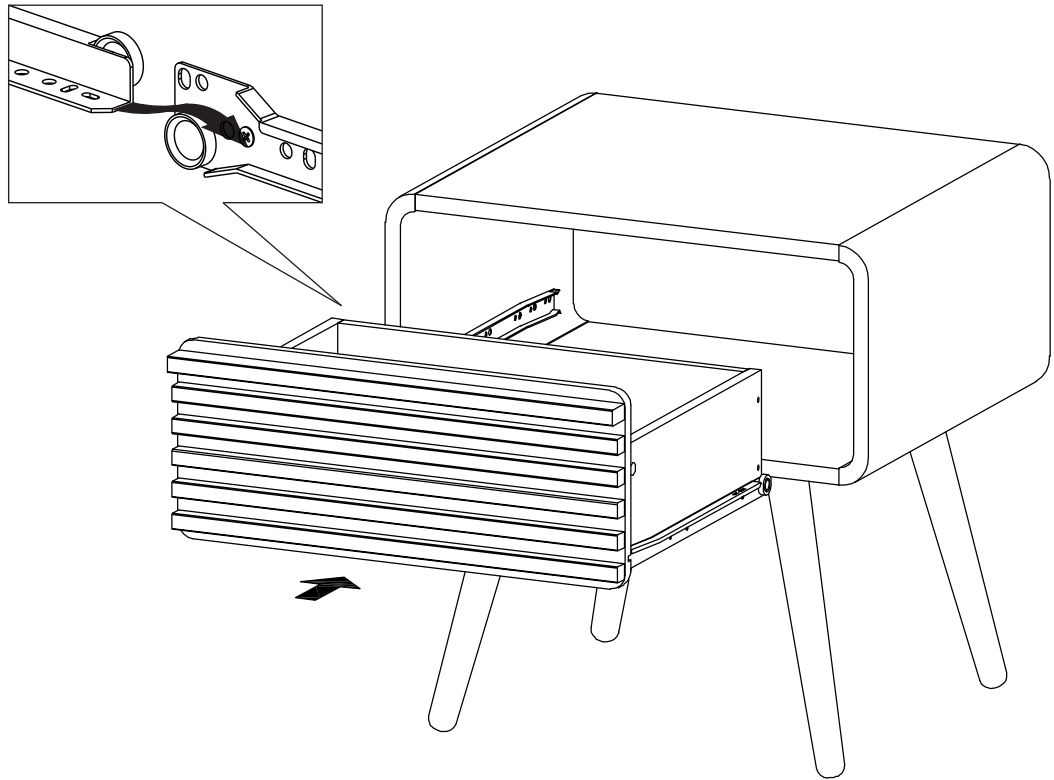

12

