

Installation & Assembly

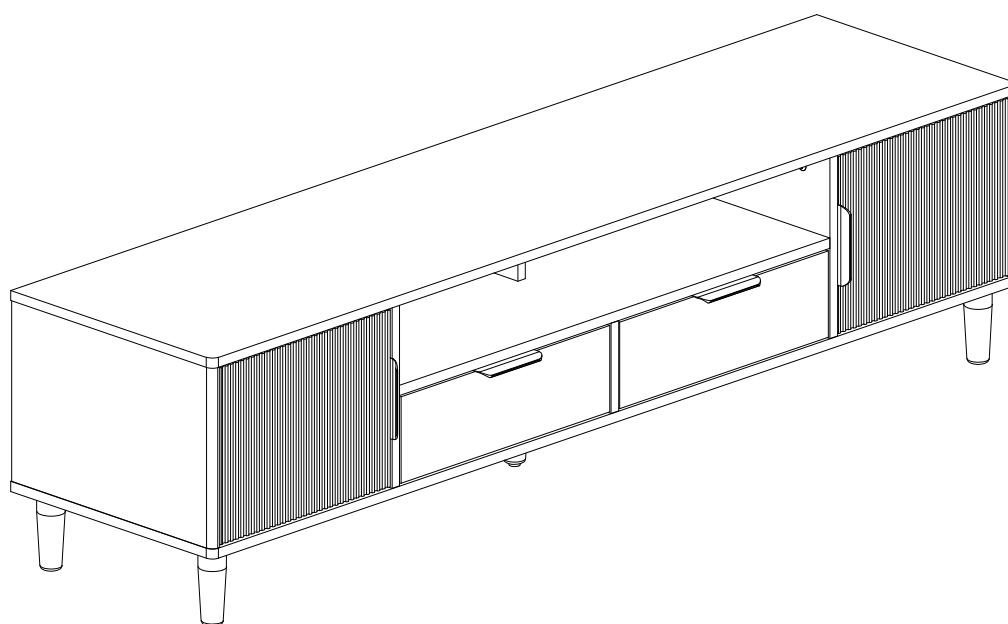

Installation Diagram

Name TV Stand-052

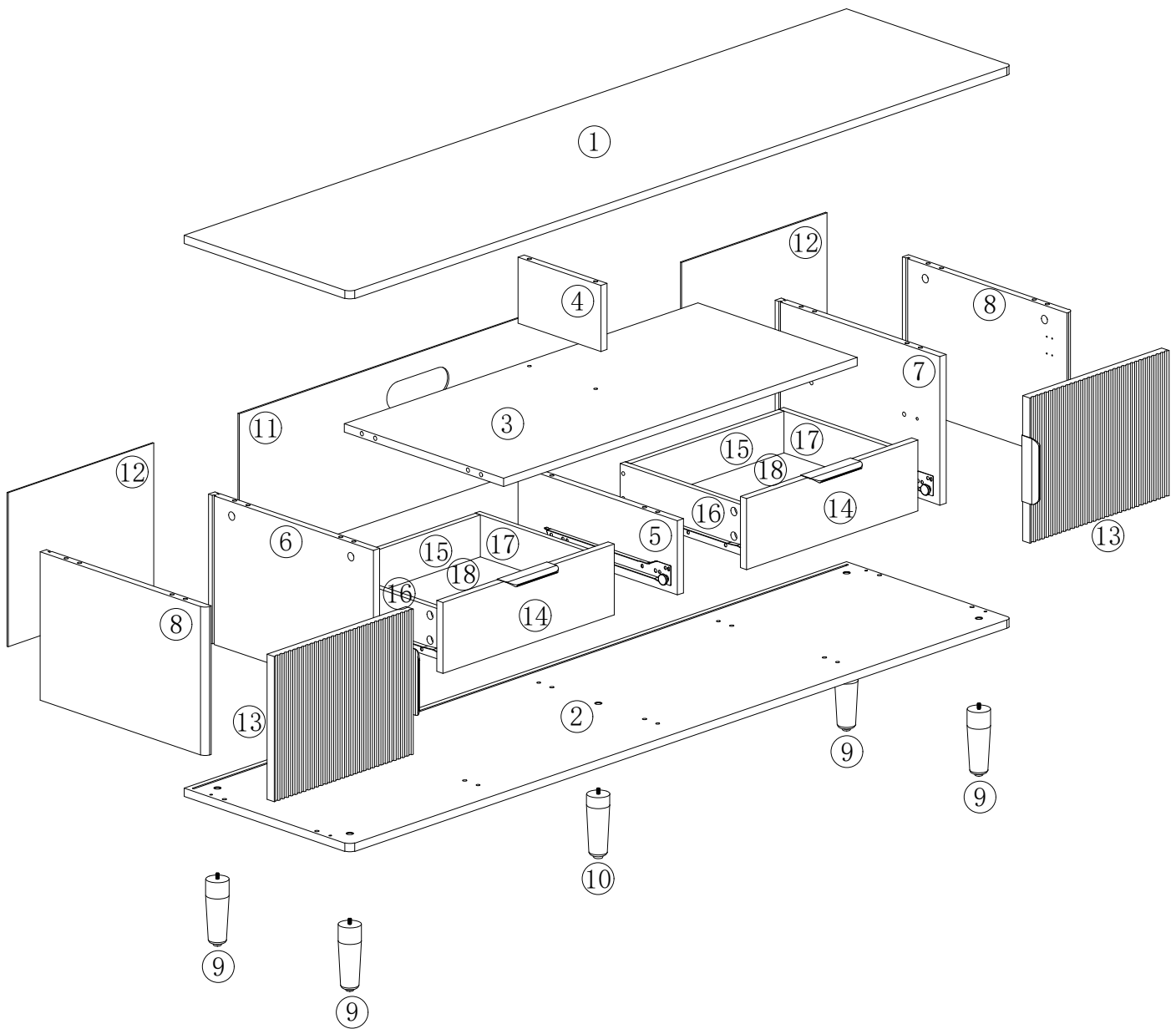

Parts List

① x1

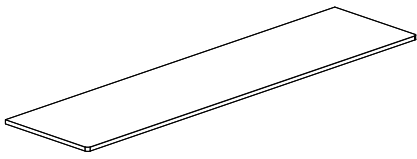

② x1

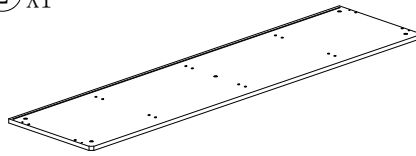

③ x1

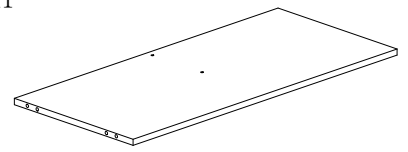

④ x1

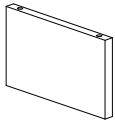

⑤ x1

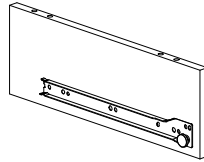

⑥ x1

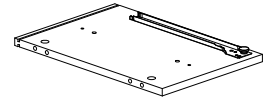

⑦ x1

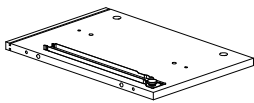

⑧ x2

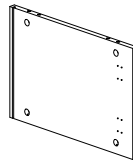

⑨ x4

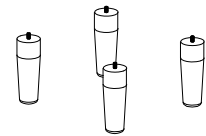

⑩ x1



⑪ x1

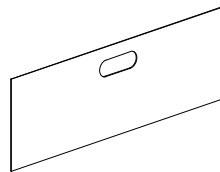

⑫ x2

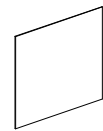

⑬ x2

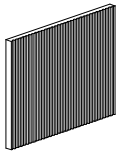

⑭ x2



⑮ x2



⑯ x2

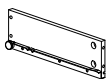

⑰ x2

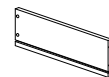

⑱ x2

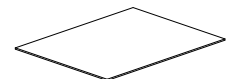



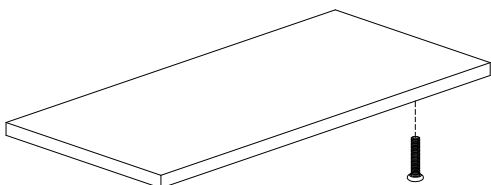



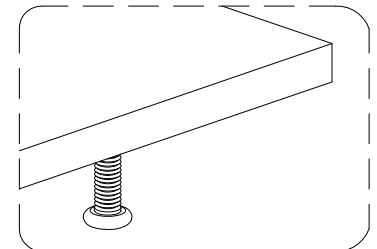
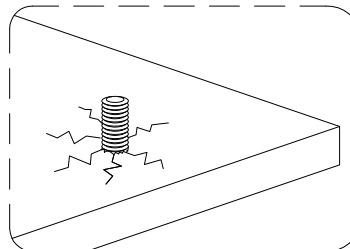

Please use the correct part/screws number. Wrong sizes may damage wood!

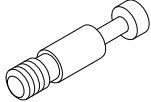
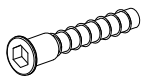
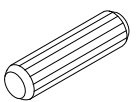
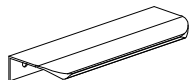

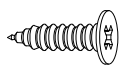
Example

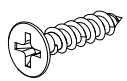
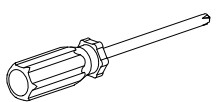
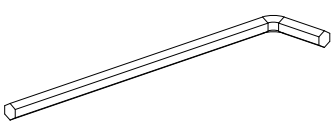

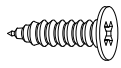
Hardware List

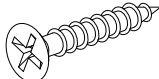
<p>A X28+3</p>  <p>15*9MM</p>	<p>B X28+3</p>  <p>L=35MM</p>	<p>C X8+1</p>  <p>M7*40MM</p>
<p>D X24+2</p>  <p>M8*30</p>	<p>E X4</p>  <p>120*37*15mm</p>	<p>F X2</p>  <p>40*12*9MM</p>
<p>G X12+1</p>  <p>3.5*14MM</p>	<p>H X4</p>  <p>∅26 Cabinet Hinges</p>	<p>I X24+2</p>  <p>3.5*14MM</p>
<p>J X1</p>  <p>M6*128MM</p>	<p>K X1</p>  <p>M4*100MM</p>	<p>L X16+2</p>  <p>13*13*9.3MM</p>
<p>M X16+2</p>  <p>#3.0*16MM</p>	<p>N X26+2</p>  <p>20MM</p>	<p>O X8+1</p>  <p>#8*30MM</p>

Name : TV Stand-052

STEP 1

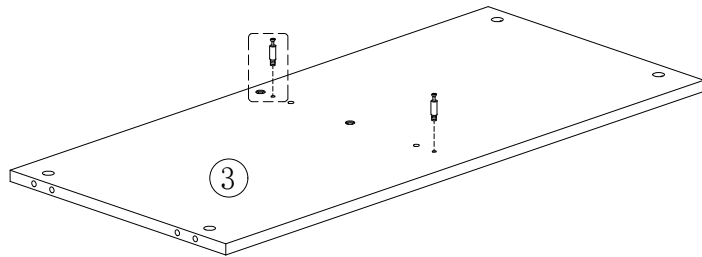
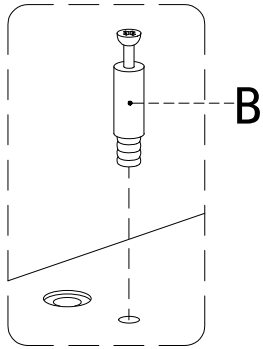

Attach screws to parts ③ (Hardware B and J)

B		X2
J		X1

STEP 2

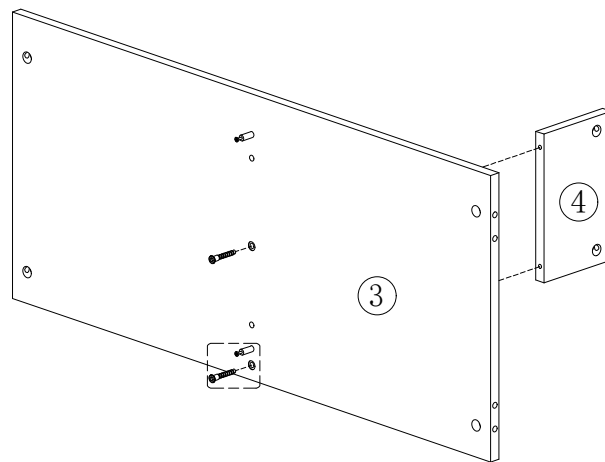
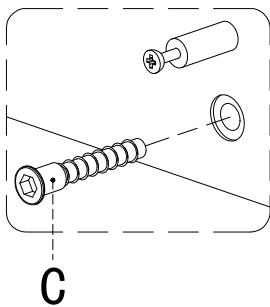

Connect part ④ to parts ③
Secure them using (Hardware C and K)



C		X2
K		X1

STEP 3

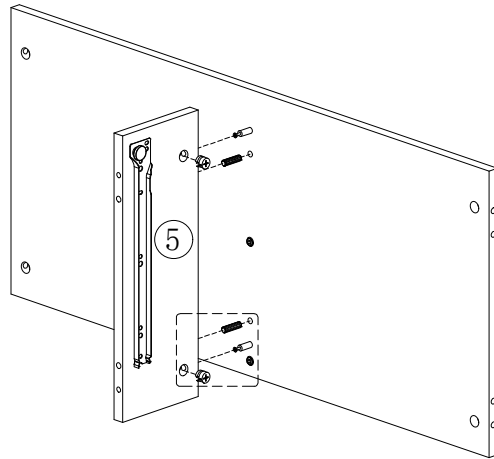
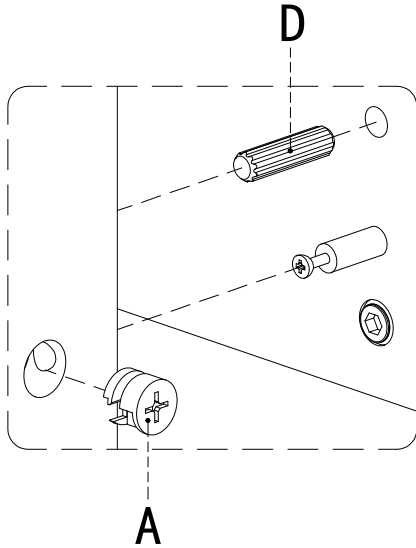
Place cam nut (A) in panel slot with arrow notch () facing screw (B) . Rotate cam nut (A) tighten clockwise.





Connect parts with the structure from Step 2
Secure them using (Hardware A,D and J)

A		X2
D		X2
J		X1

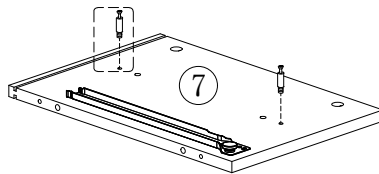
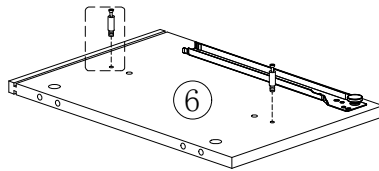
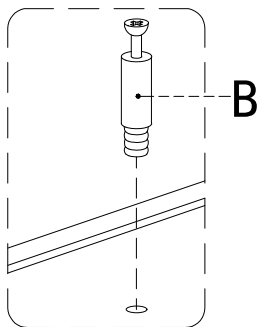
STEP 4



Attach screws to parts ⑥ and parts ⑦ (Hardware B and J)

B		X4
J		X1

Name : TV Stand-052

STEP 5

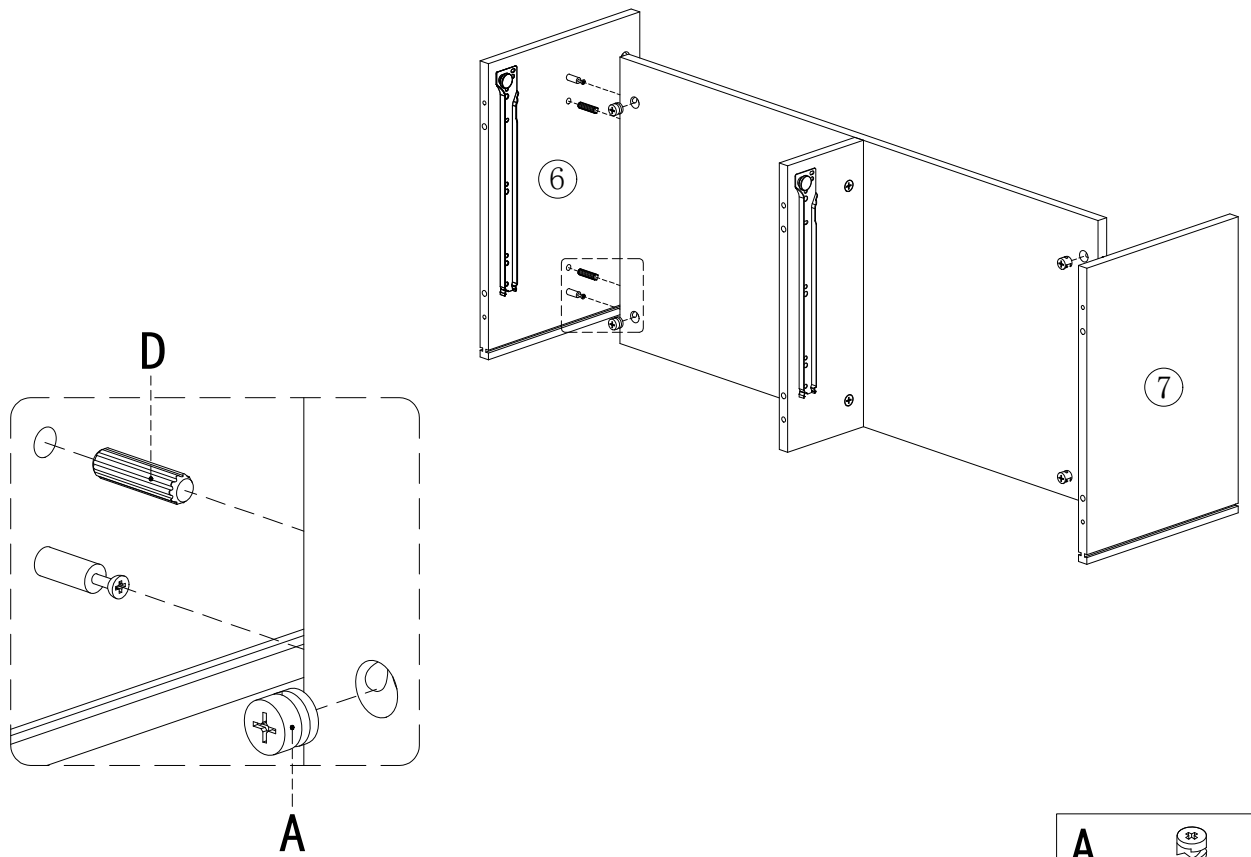

Connect the assembly from STEP 3 with the structure from STEP4
Secure them using (Hardware A,D and J)

A		X4
D		X4
J		X1

STEP 6

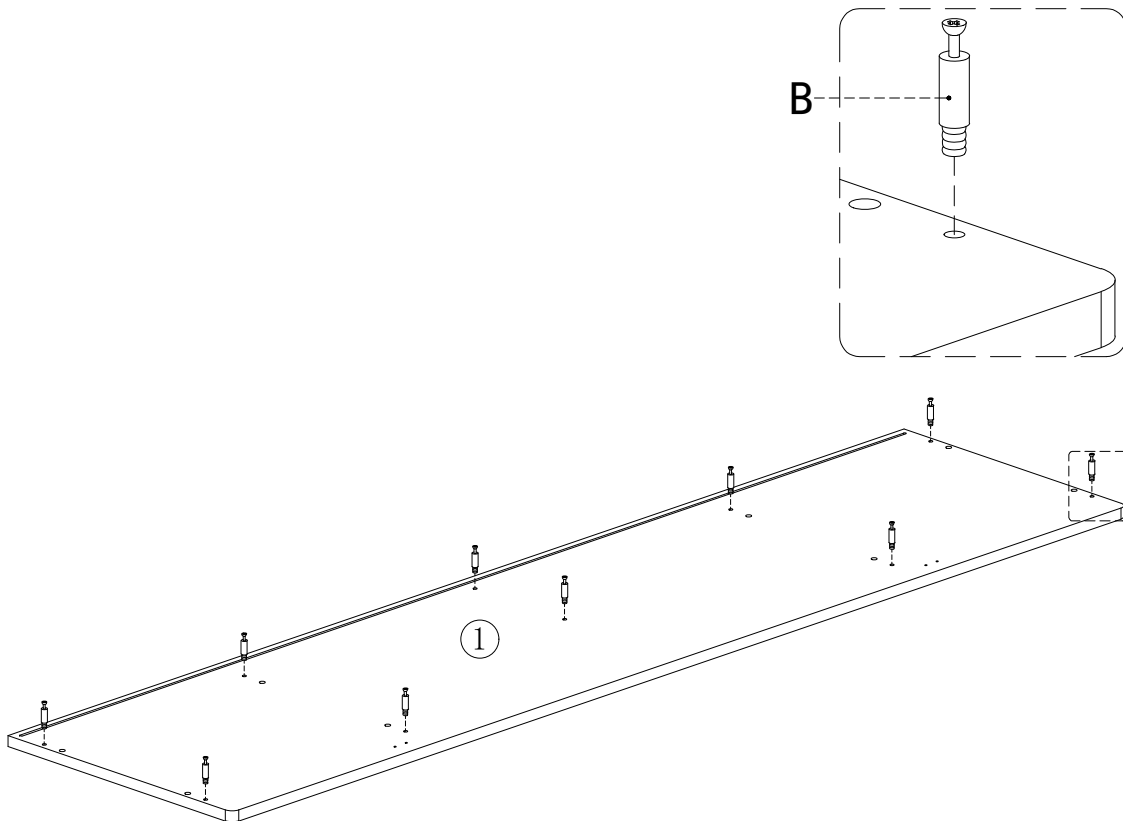

Attach screws to parts ① (Hardware B and J)

B		X10
J		X1

STEP 7

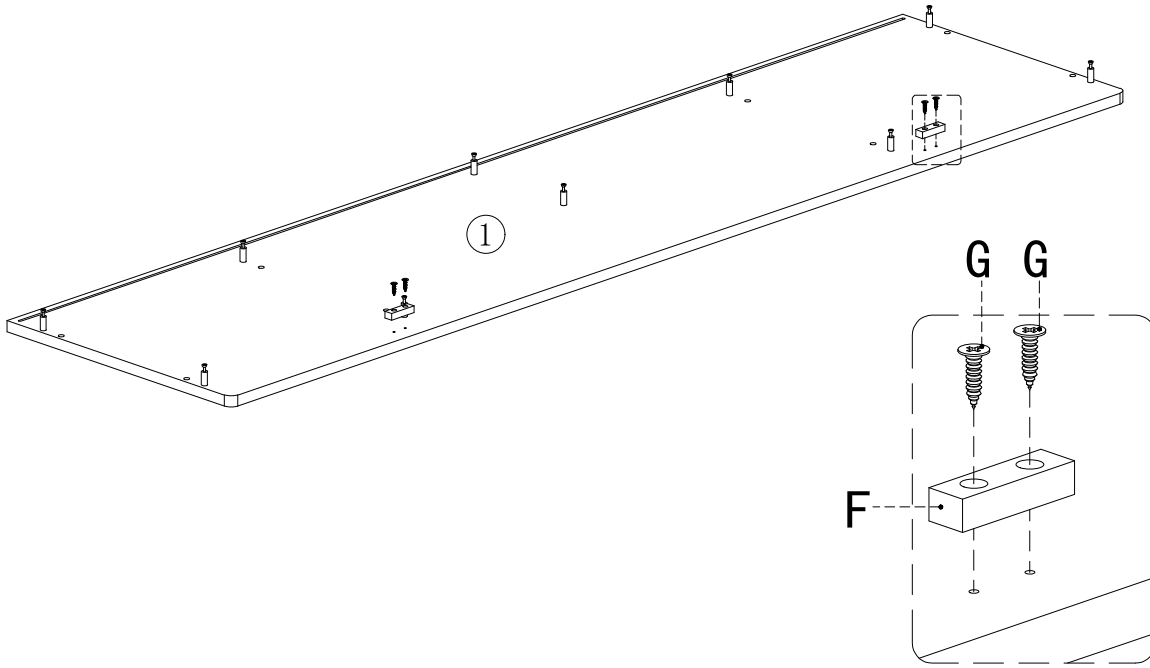

Attach screws to parts ① (Hardware F,G and J)

F		X2
G		X4
J		X1

STEP 8

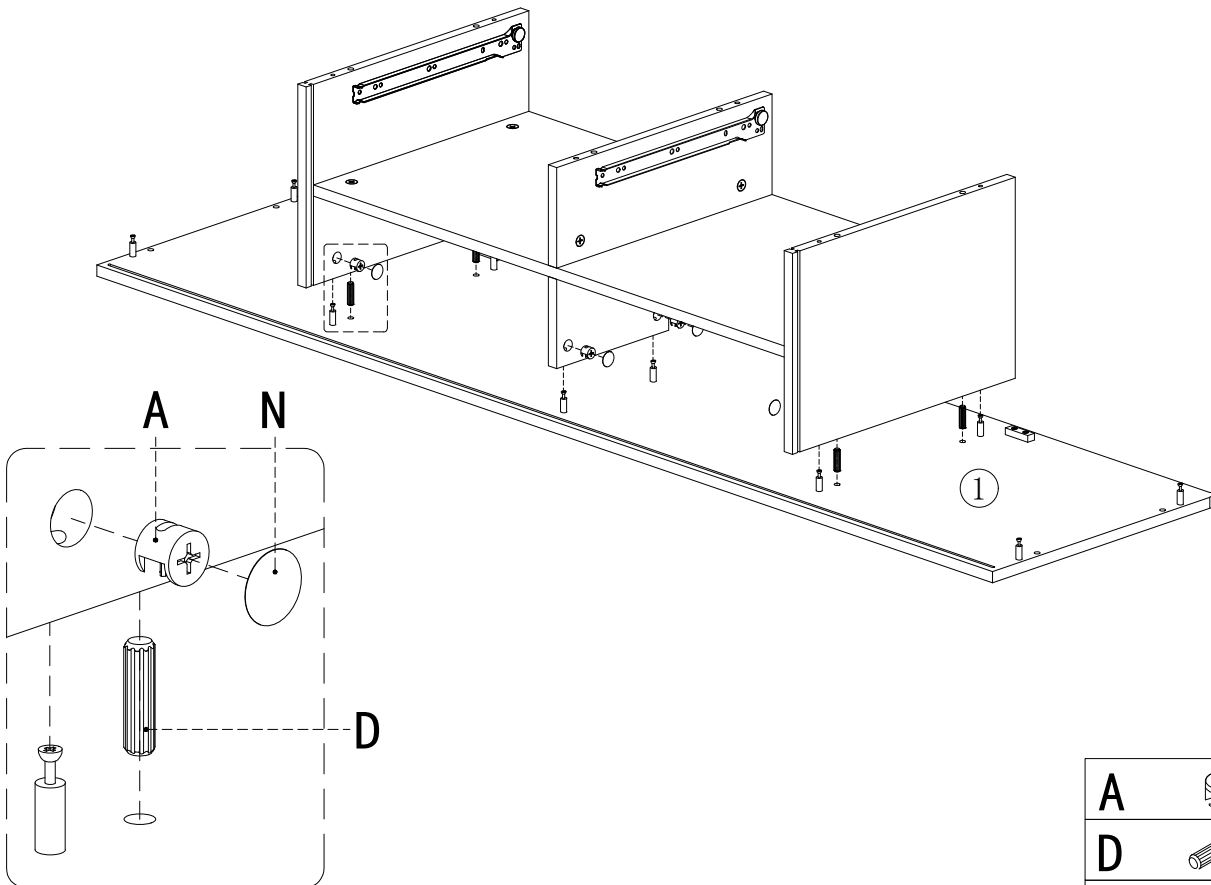

Connect the assembly from STEP 5 with the structure from STEP 7
Secure them using (Hardware A,D ,N and J)

A		X6
D		X4
N		X6
J		X1

Name : TV Stand-052

STEP 9

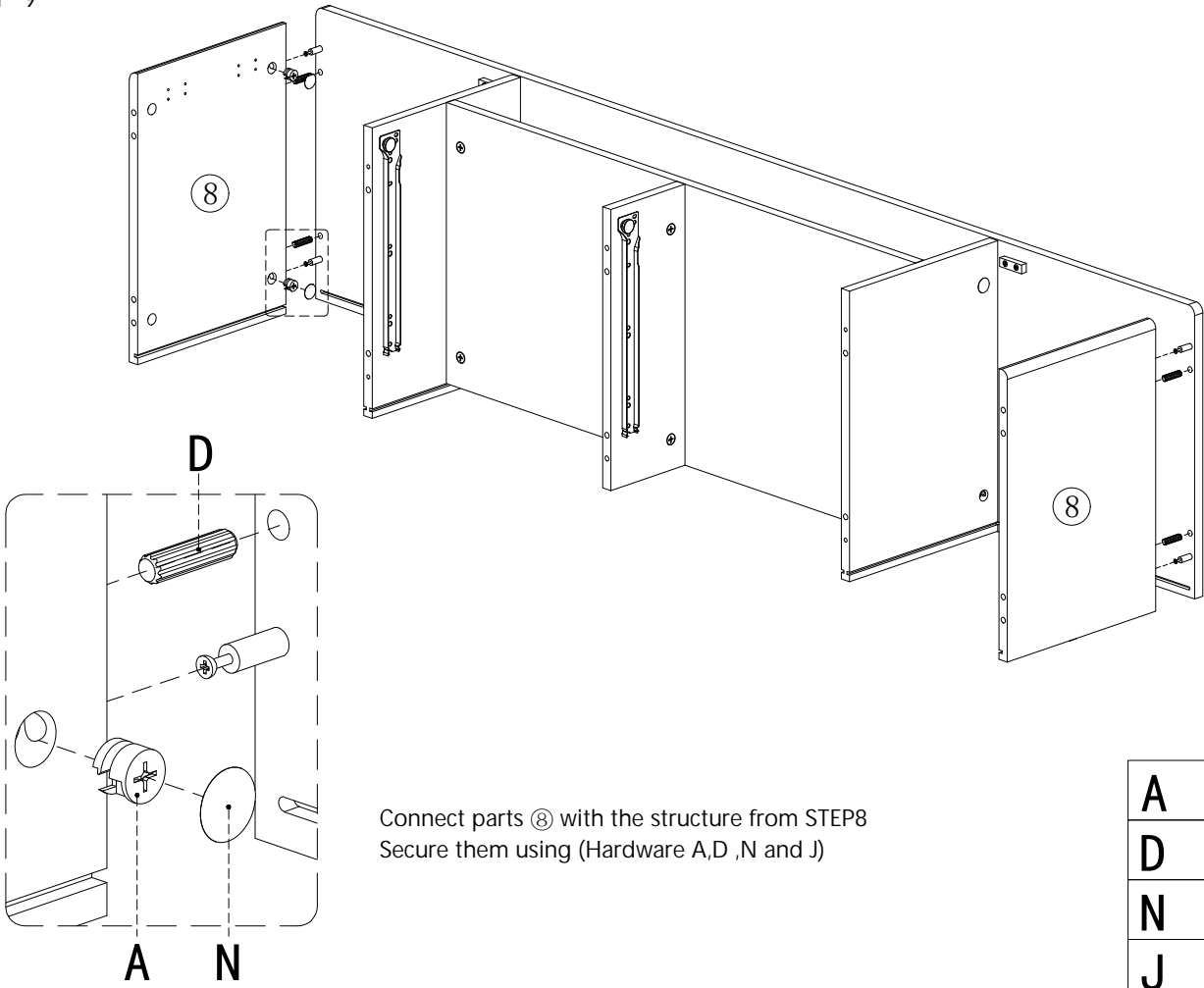

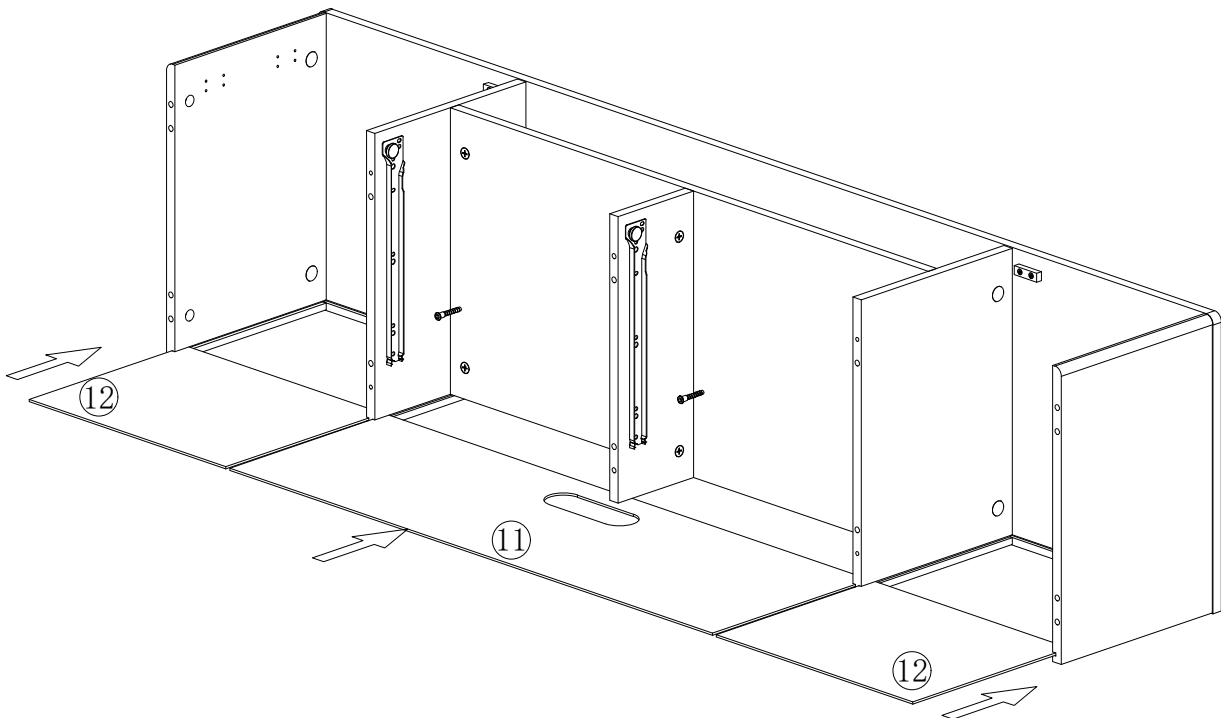

STEP 10

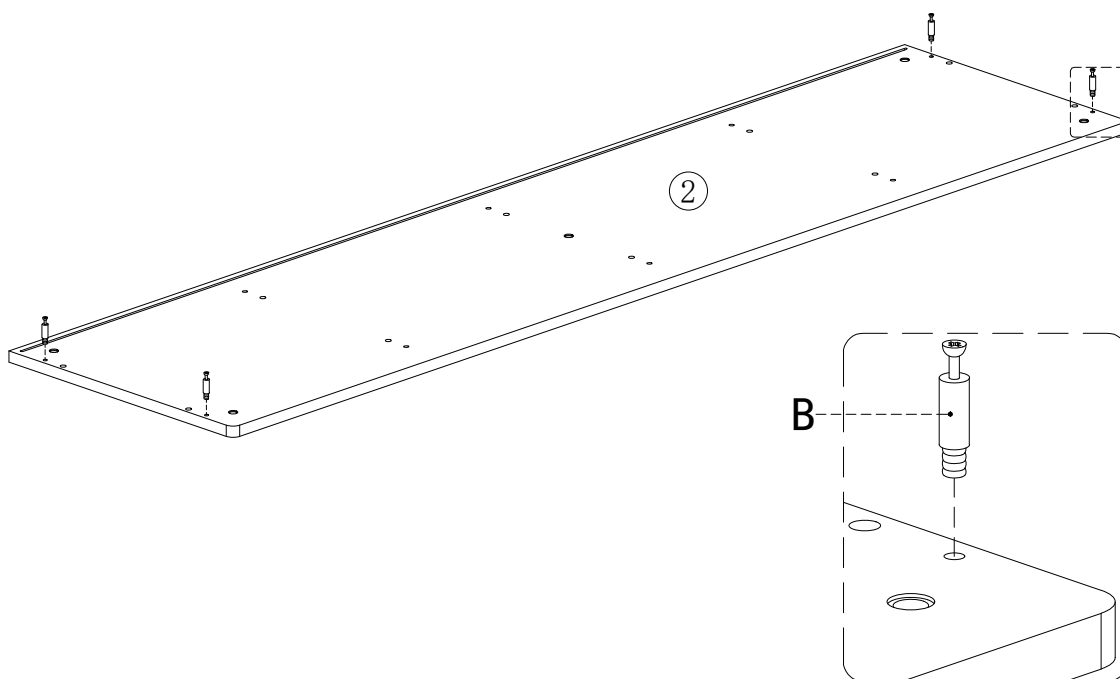

STEP 11



Attach screws to parts ② (Hardware B and J)

B		X4
J		X1

STEP 12

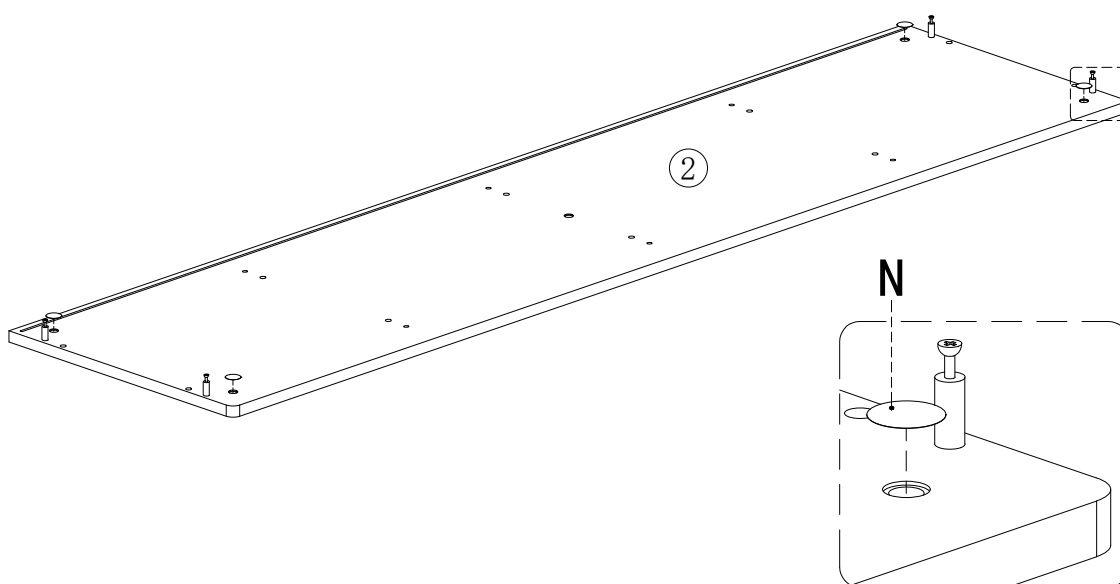

Place hardware N over the four corner holes on parts ② to cover them





N		X4
----------	---	----

Name : TV Stand-052

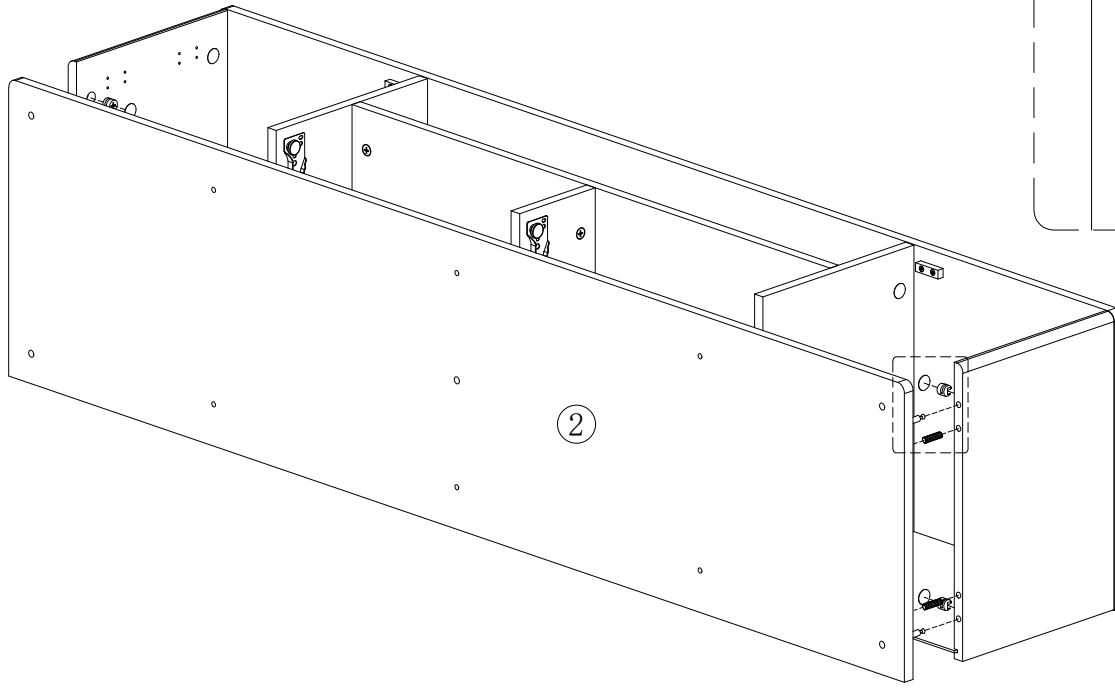
STEP 13

Connect the assembly from STEP 10 with the structure from STEP12
Secure them using (Hardware A,D,N and J)



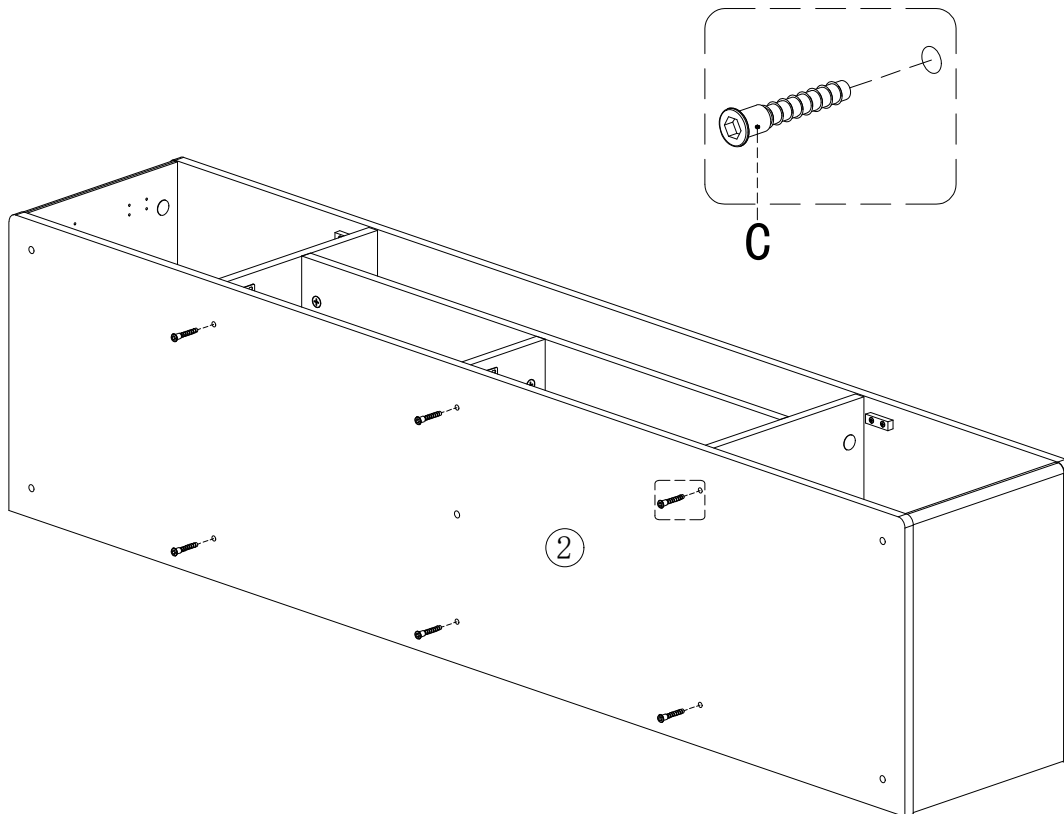

A		X4
D		X10
N		X4
J		X1

STEP 14



Attach screws to parts ② (Hardware C and K)

C		X6
K		X1

STEP 15

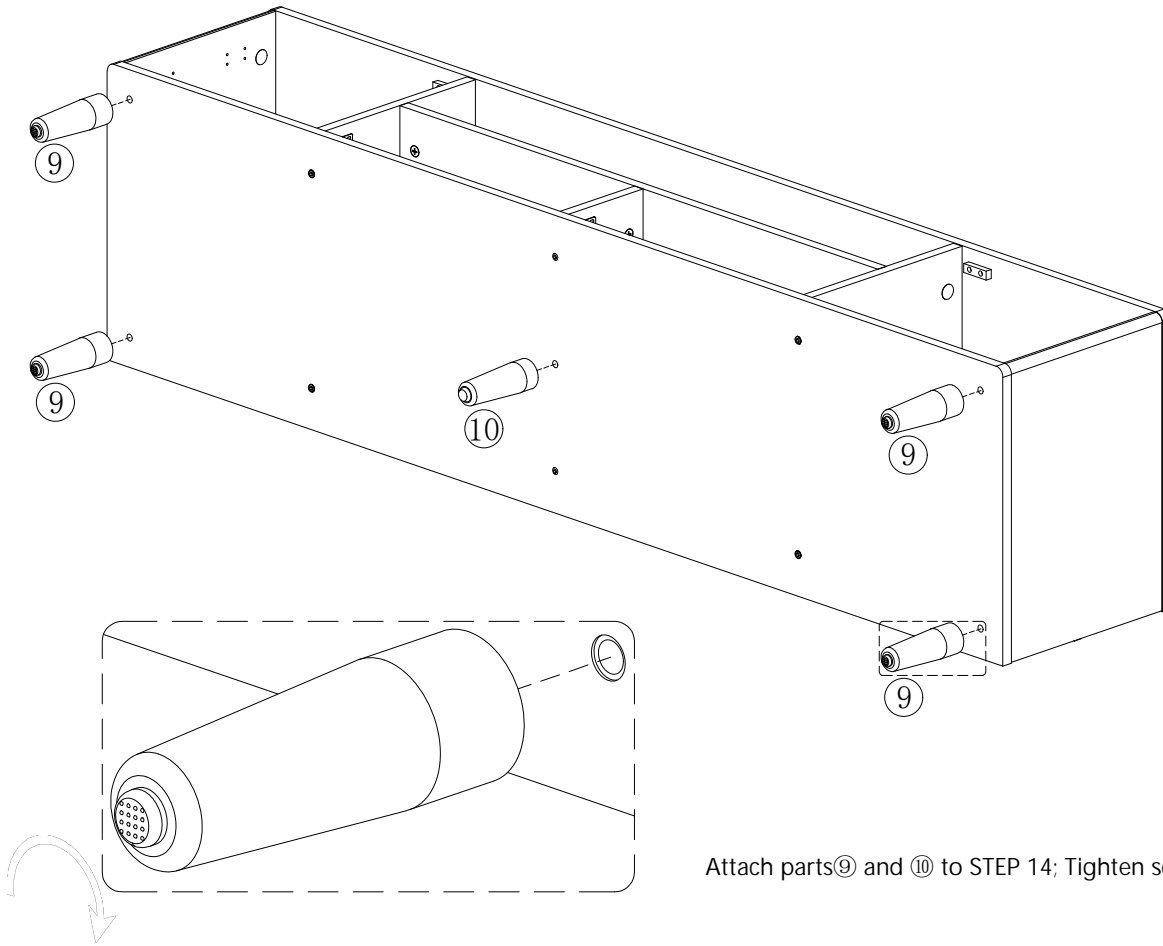

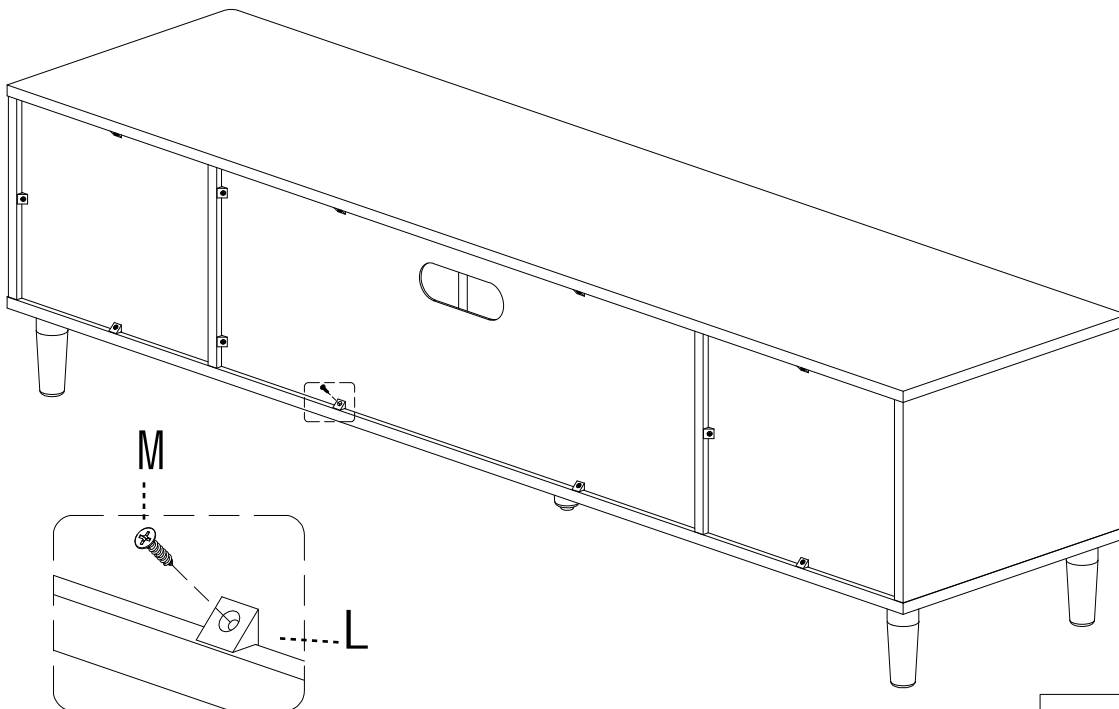

Attach parts 9 and 10 to STEP 14; Tighten screws clockwise

STEP 16





Attach screws to the back of the TV cabinet (Hardware M, L and J)

L		X16
M		X16
J		X1

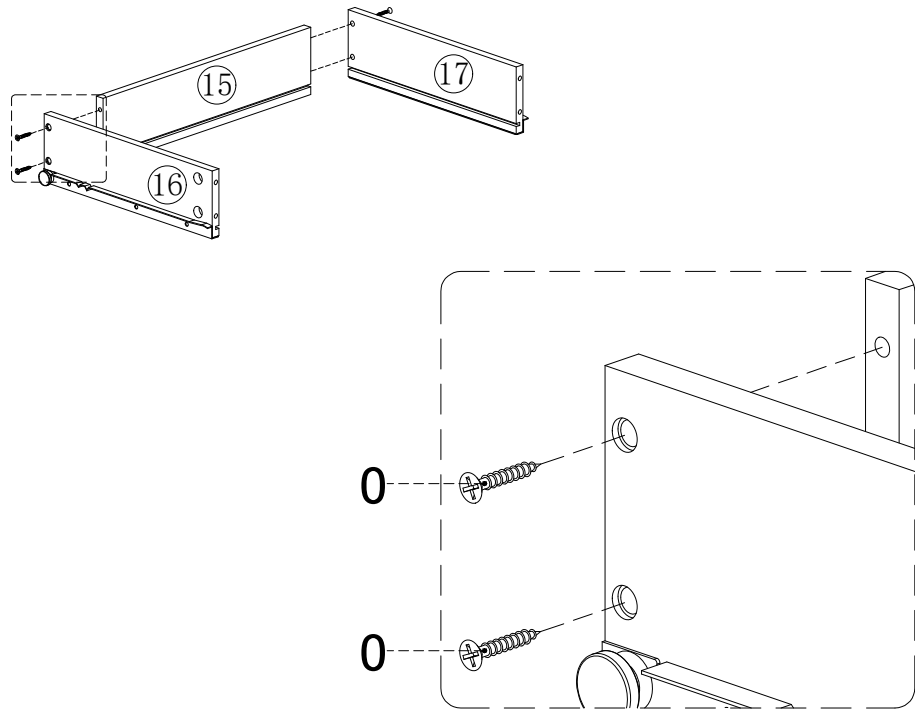
STEP 17



Connect part (15) and part (16) to parts (17)
Secure them using (Hardware O and J)

O		X8
J		X1

STEP 18

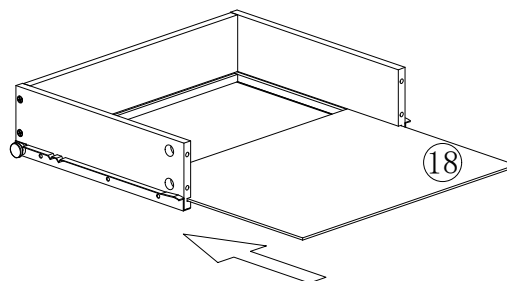

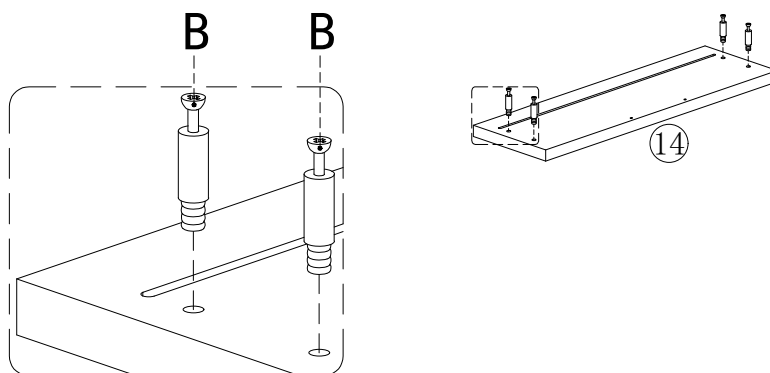

Repeat STEP17 to install two sets of drawers.

STEP 19





Attach screws to parts (14) (Hardware B and J)

B		X8
J		X1

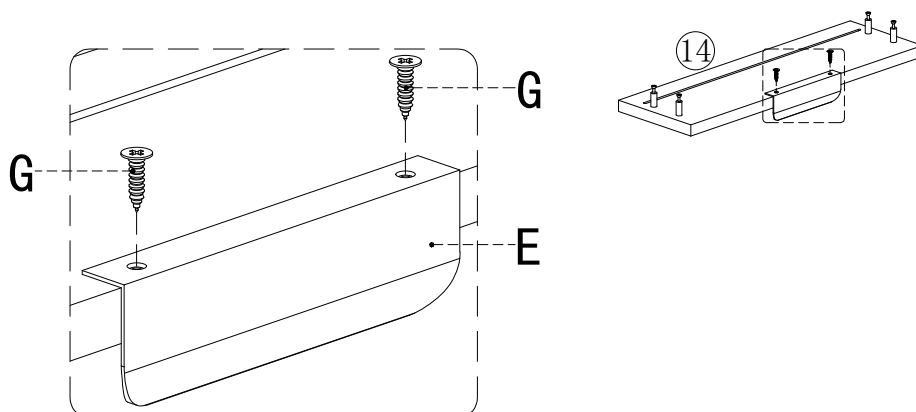
STEP 20





Attach screws to parts (14) (Hardware E,G and J)

E		X2
G		X4
J		X1

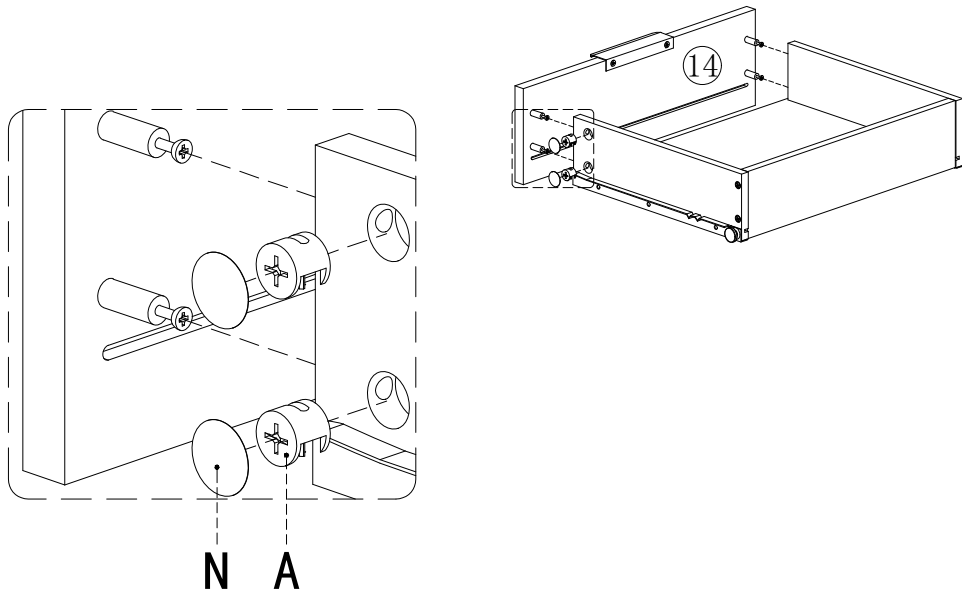
STEP 21



Connect the assembly from STEP 18 with the structure from STEP 20
Secure them using (Hardware A,N and J)

A		X8
N		X8
J		X1

STEP 22

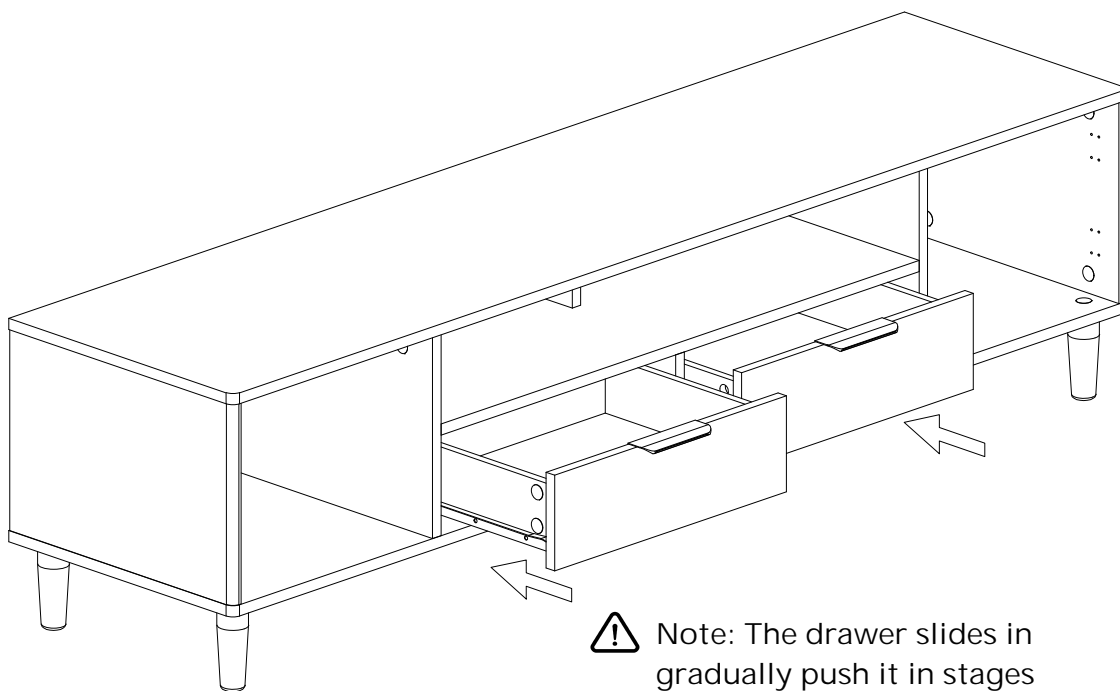

 Note: The drawer slides in gradually push it in stages until fully inserted.

STEP 23

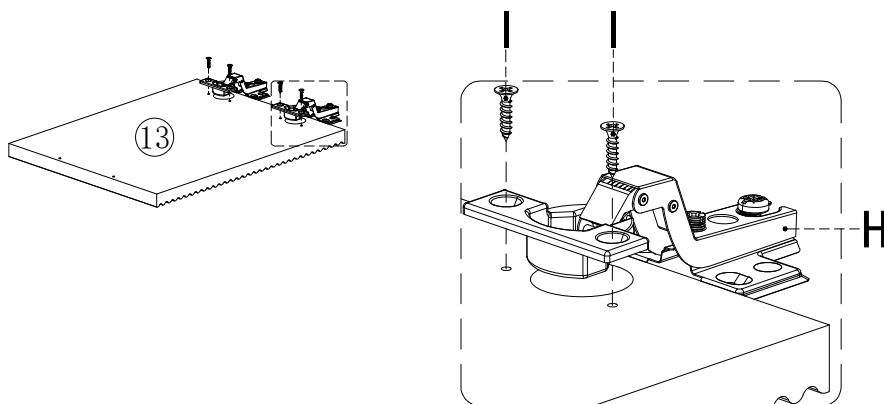

Attach screws to parts ⑬ (Hardware H, I and J)

H		X4
I		X8
J		X1

STEP 24

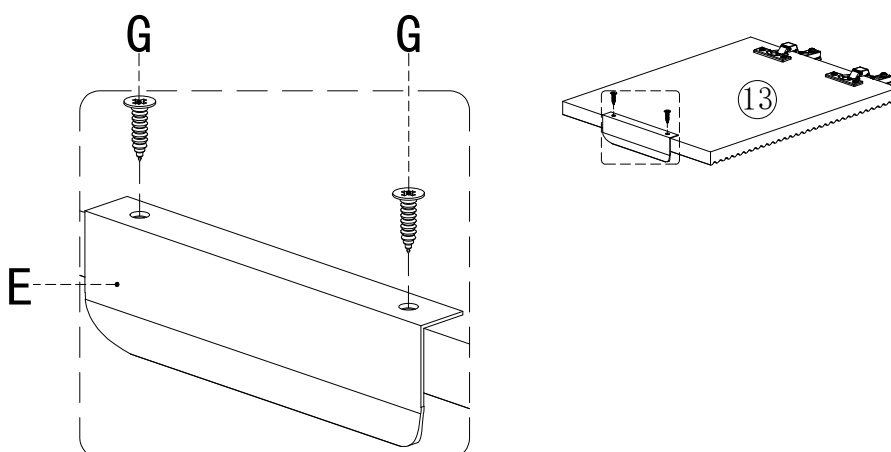

Attach screws to parts ⑬ (Hardware E, G and J)

E		X2
G		X4
J		X1

Name : TV Stand-052

STEP 25

Connect the assembly from STEP 22 with the structure from STEP 24
Secure them using (Hardware I and J)

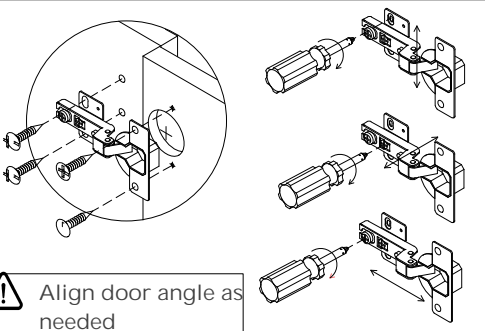
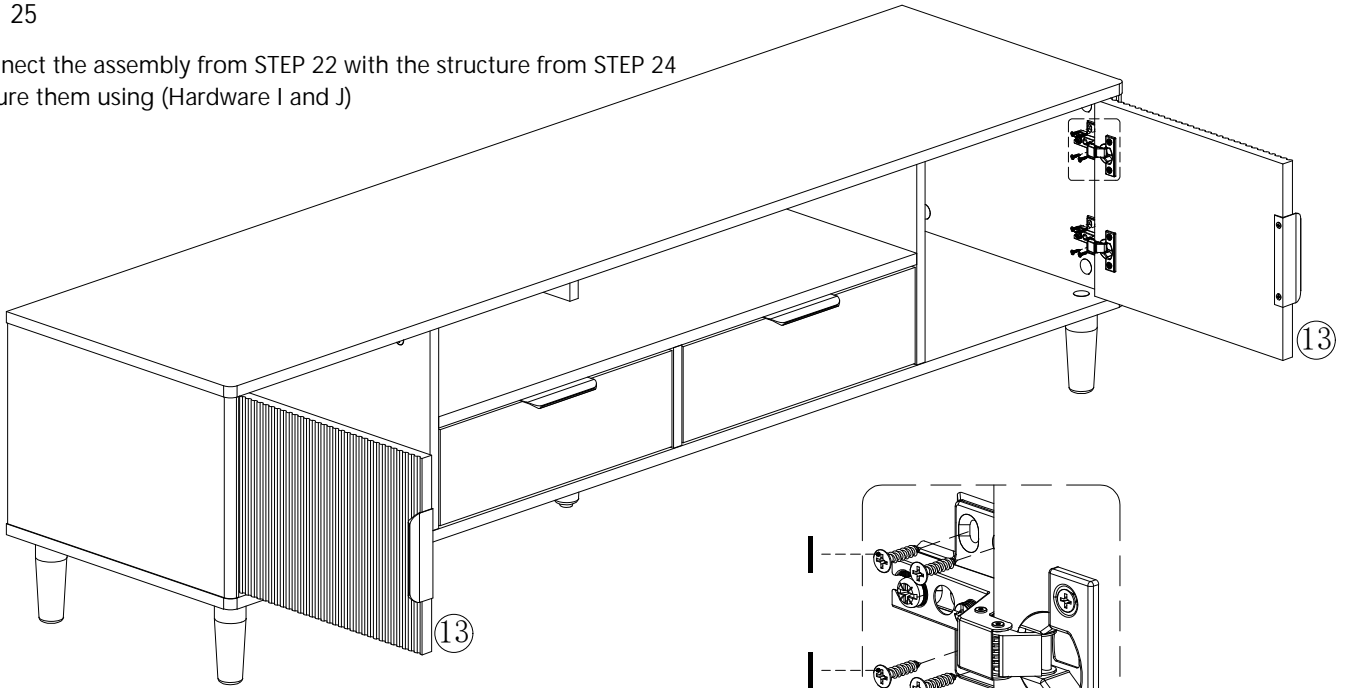



Adjust door up-down position

Adjust door left-right position

Adjust door front-back position

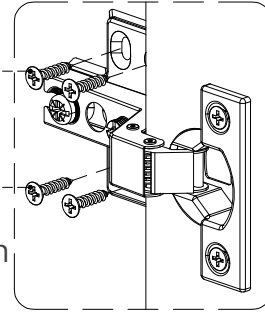
 Align door angle as needed



I		X16
J		X1

STEP 26

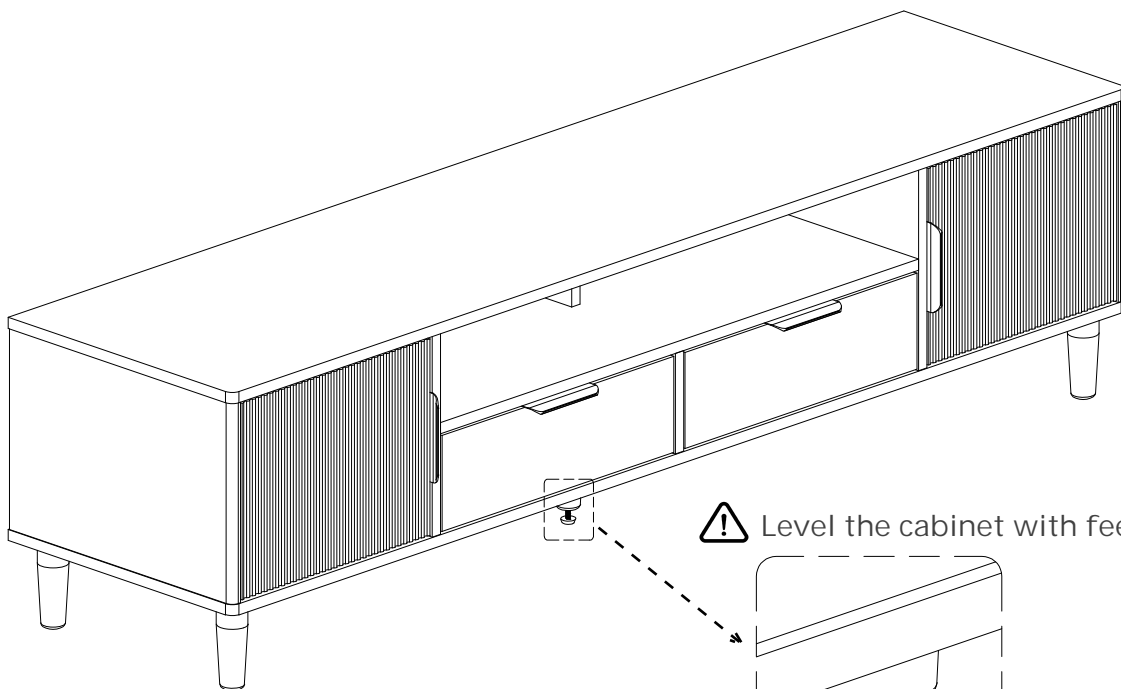

 Level the cabinet with feet pads

