

USER'S MANUAL

Product Name: **Lounge Chair**

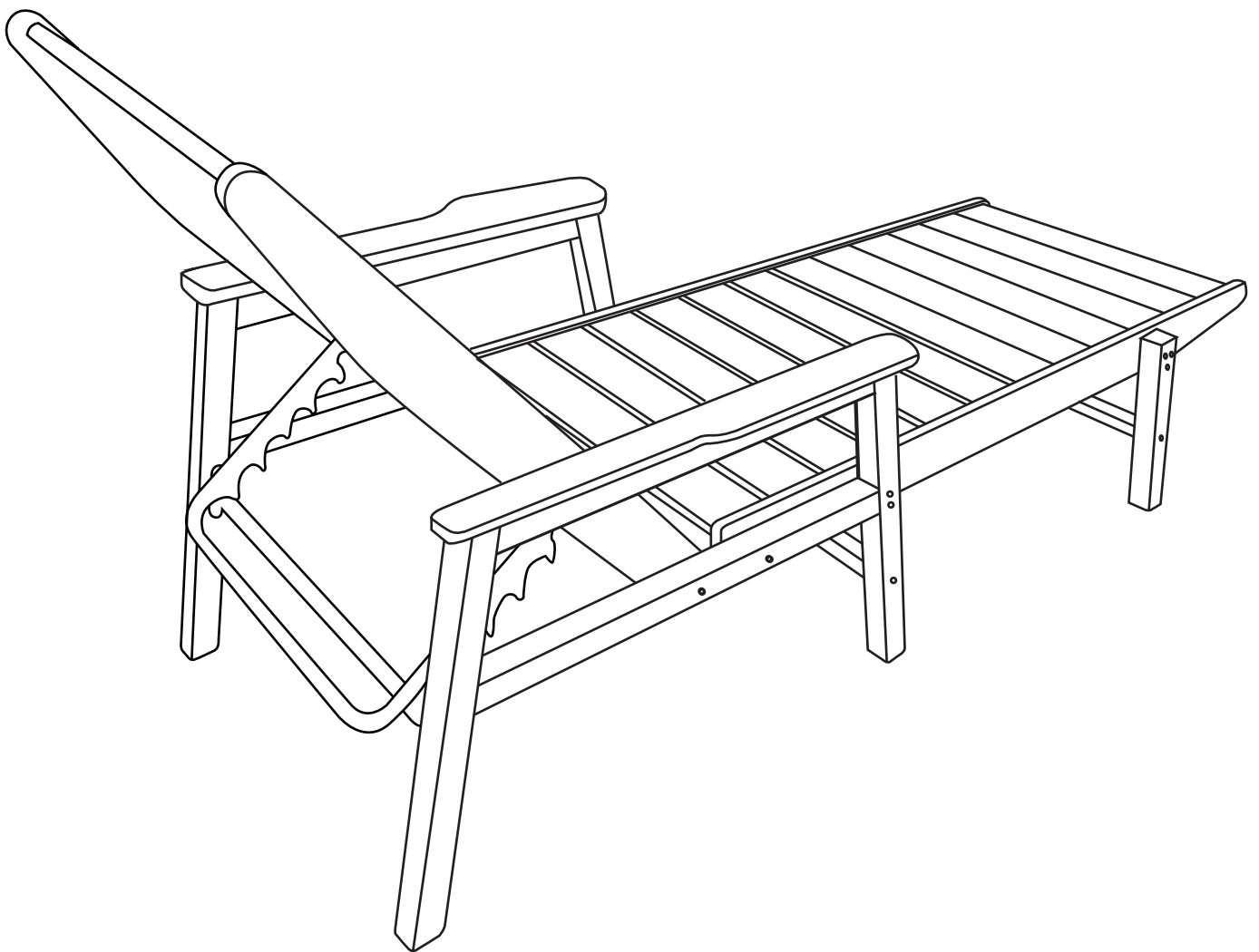

THIS INSTRUCTION BOOKLET CONTAINS **IMPORTANT SAFETY INFORMATION.**

PLEASE READ AND KEEP FOR FUTURE REFERENCE.

Contact Us

If you have any problem, please give us a chance to make it right for you!

Contact our friendly customer service department for help first. Replacements for missing or damaged parts will be shipped ASAP!



Before You Start

- Please read all instructions carefully.
- Retain instructions for future reference.
- Separate and count all parts and hardware.
- Read through each step carefully and follow the proper order.
- We recommend that, where possible, all items are assembled near to the area in which they will be placed in use, to avoid moving the product unnecessarily once assembled.
- Always place the product on a flat, steady and stable surface.
- Keep all small parts and packaging materials for this product away from babies and children.

KNOW YOUR PARTS

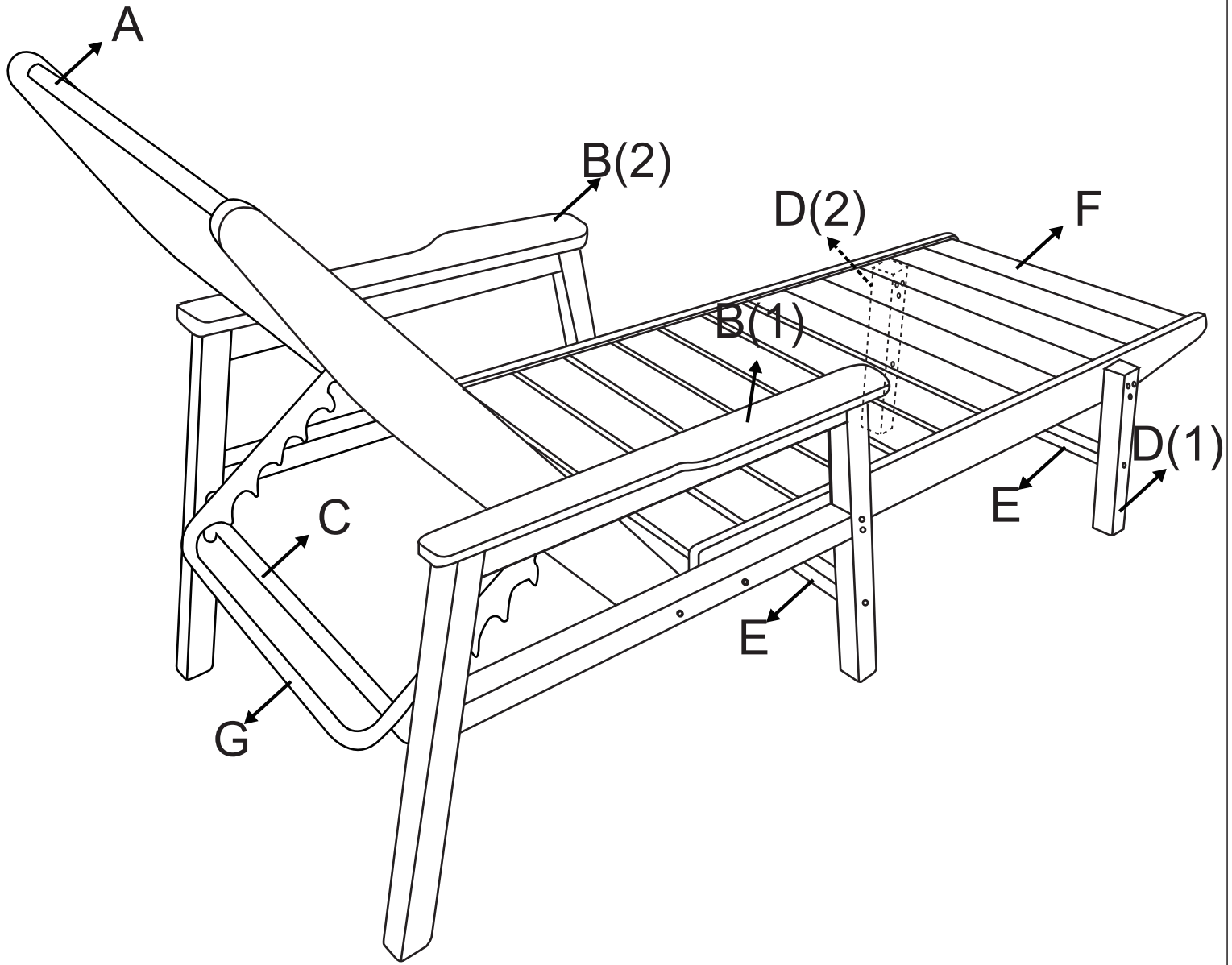

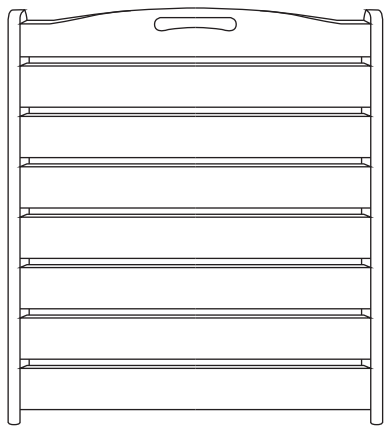

Part A x 1

Surface



Inside

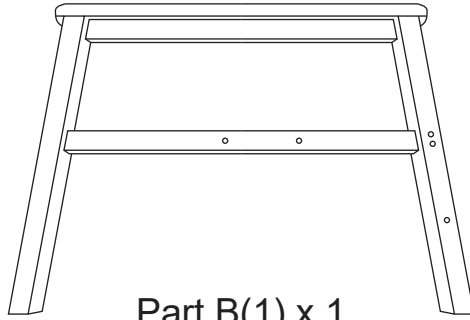

Part B(1) x 1

Surface



Inside

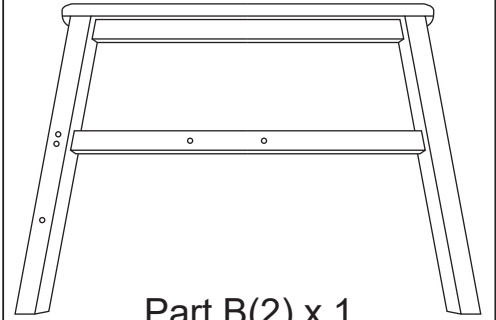

Part B(2) x 1



Part D(1) x 1

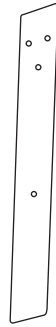

Part D(2) x 1



Part E x 2

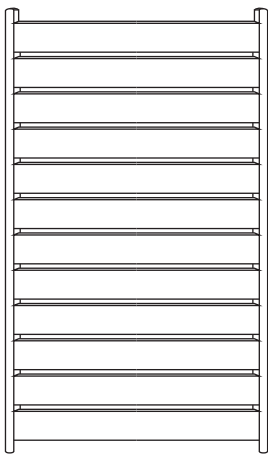

Part F x 1



Part C x 1



Part G x 1

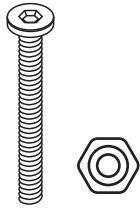

Screw A (70mm) x 14
Nut x 14

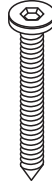

Screw B (60mm) x 4



Screw C (15mm) x 4

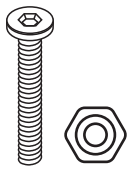

Screw D (55mm) x 2
Nut x 2



Plastic gasket E x 4

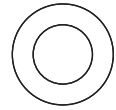

Iron gasket F x 4



Latch G x 4



Wrench A x 1

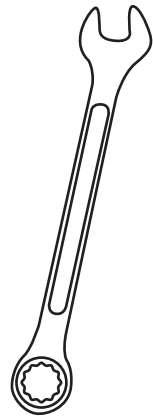

Wrench B x 1

ASSEMBLY SETPS

Step 1:

Take out Part E x 2 and install them on Part B(1) x 1 and Part D(1) x 1 respectively, using Screw B x 2 and Latch G x 2 (As shown in the figure below)

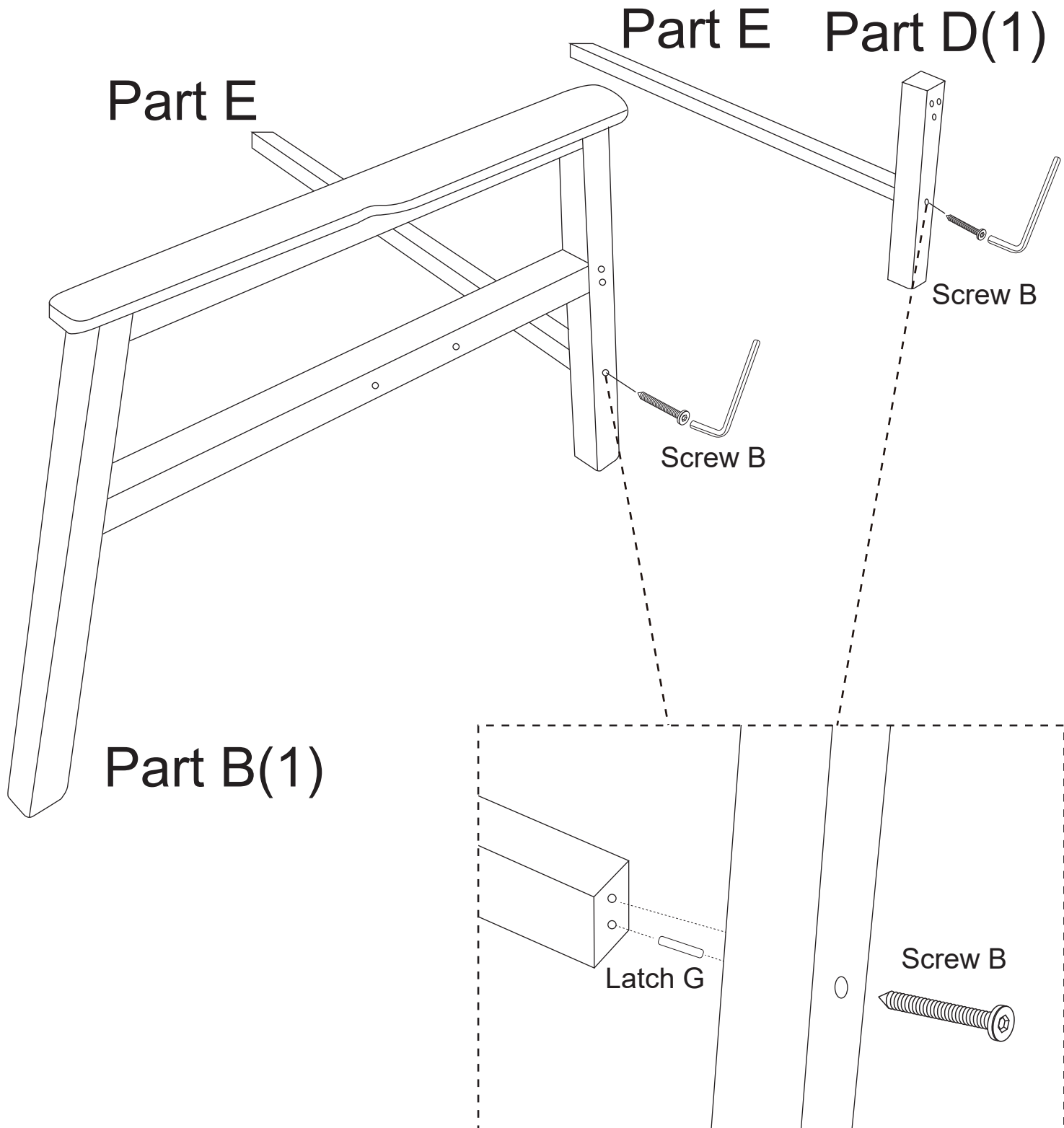
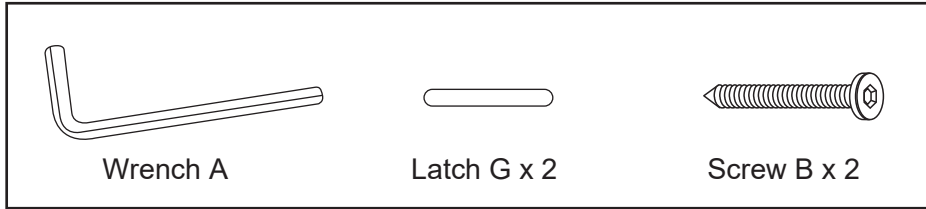

Step 2:

Take out Part F x 1 and install it on Part B(1) x 1 and Part D(1) x 1, using Screw A x 6 (As shown in the figure below)

PS: Please note that Screw A is a non-slip Screw. Use a Wrench to clamp the Nut and then tighten it with a hexagon Wrench.

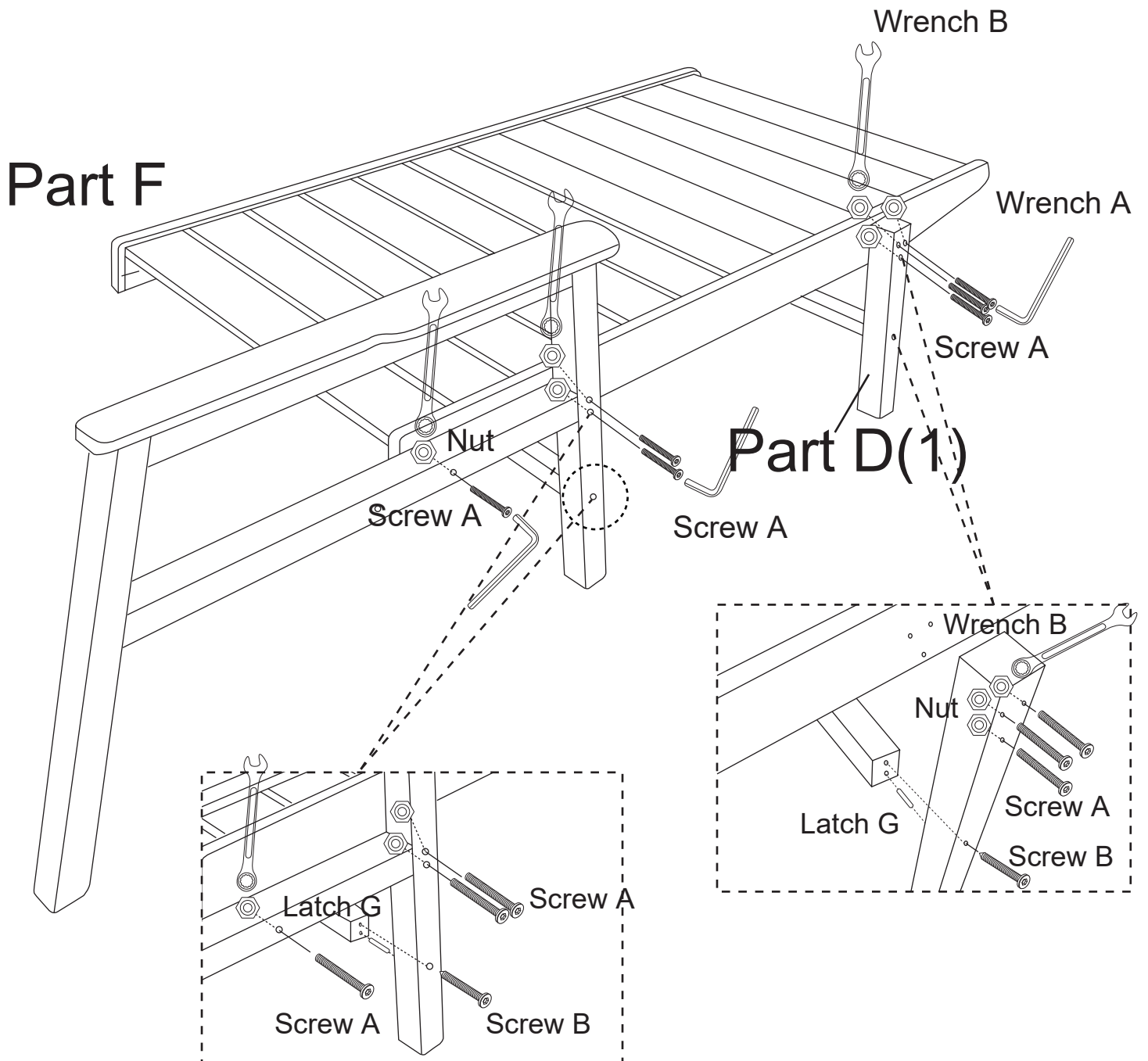
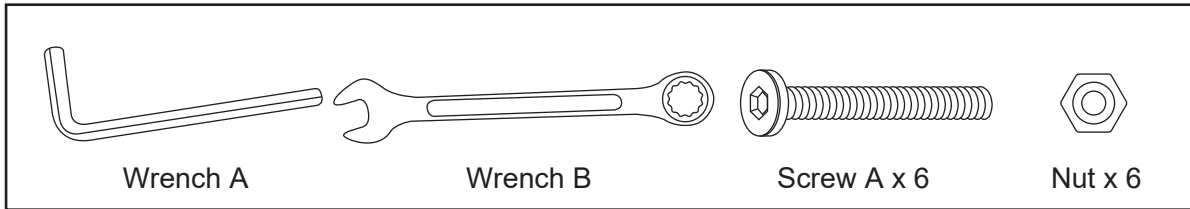

Step 4:

Take out Part C x1 and install it on Part B (1) x 1 and Part B (2) x1. Use Screw C x 4(As shown in the figure below)

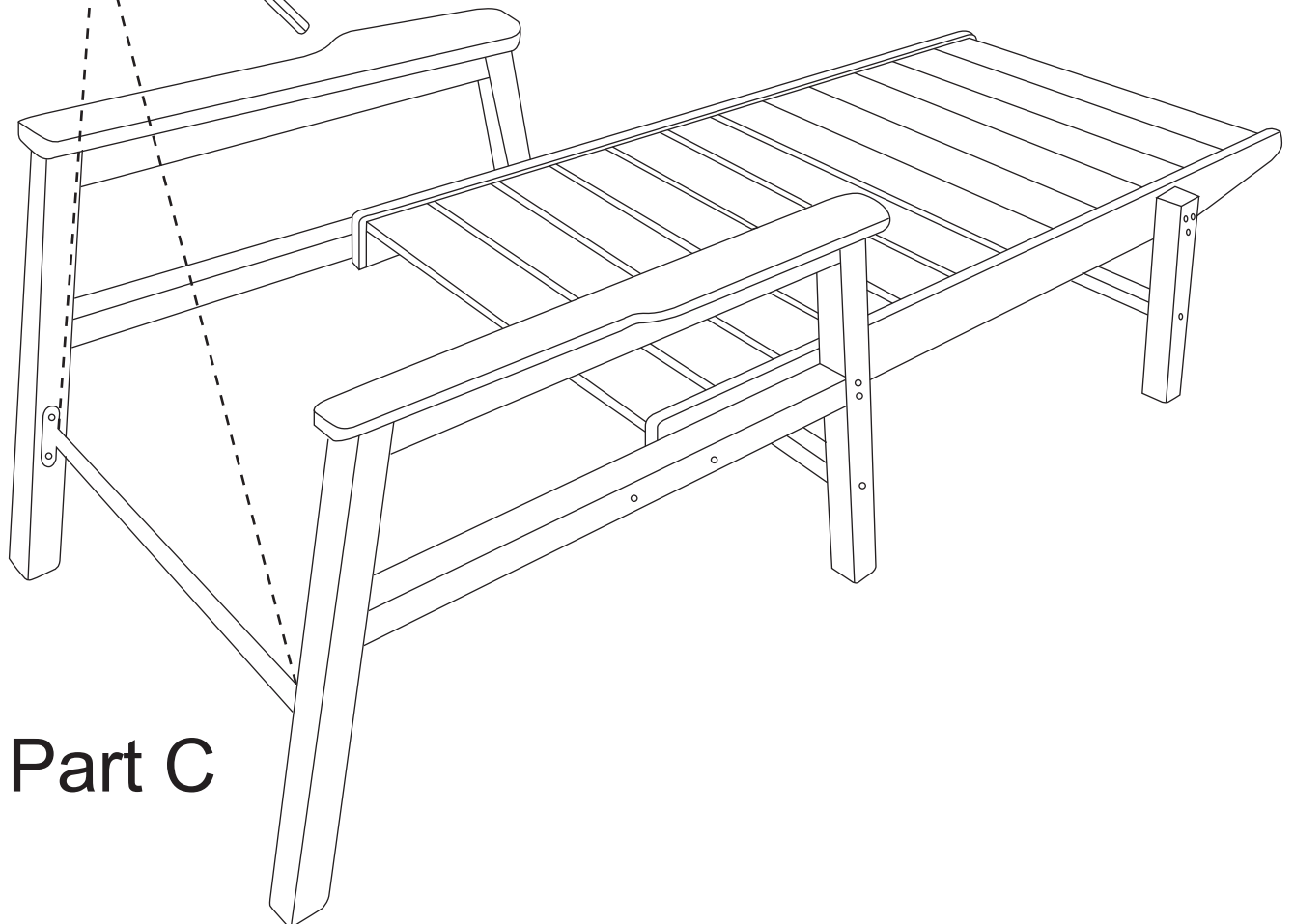
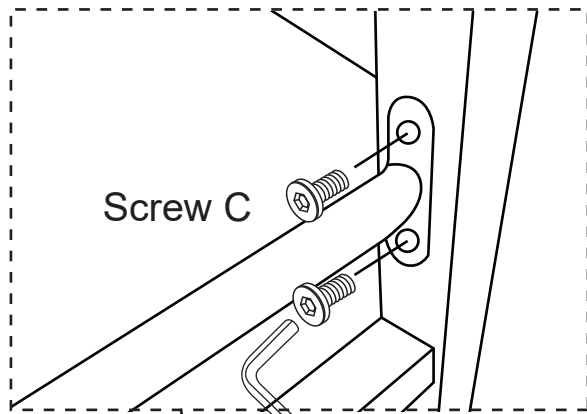
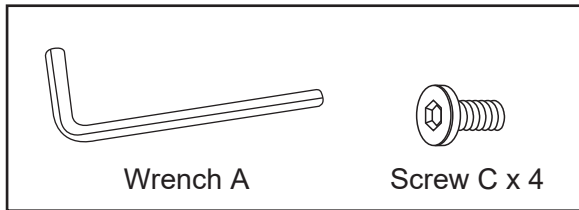

Step 5:

Take out Part G x 1 and Part A x 1 for installation, using Screw D x 2, Plastic gasket E x 2 and Iron gasket F x 2 (As shown in the figure below)

PS: Please note that Screw D is a non-slip Screw. Use a Wrench to clamp the Nut and then tighten it with a hexagon Wrench.

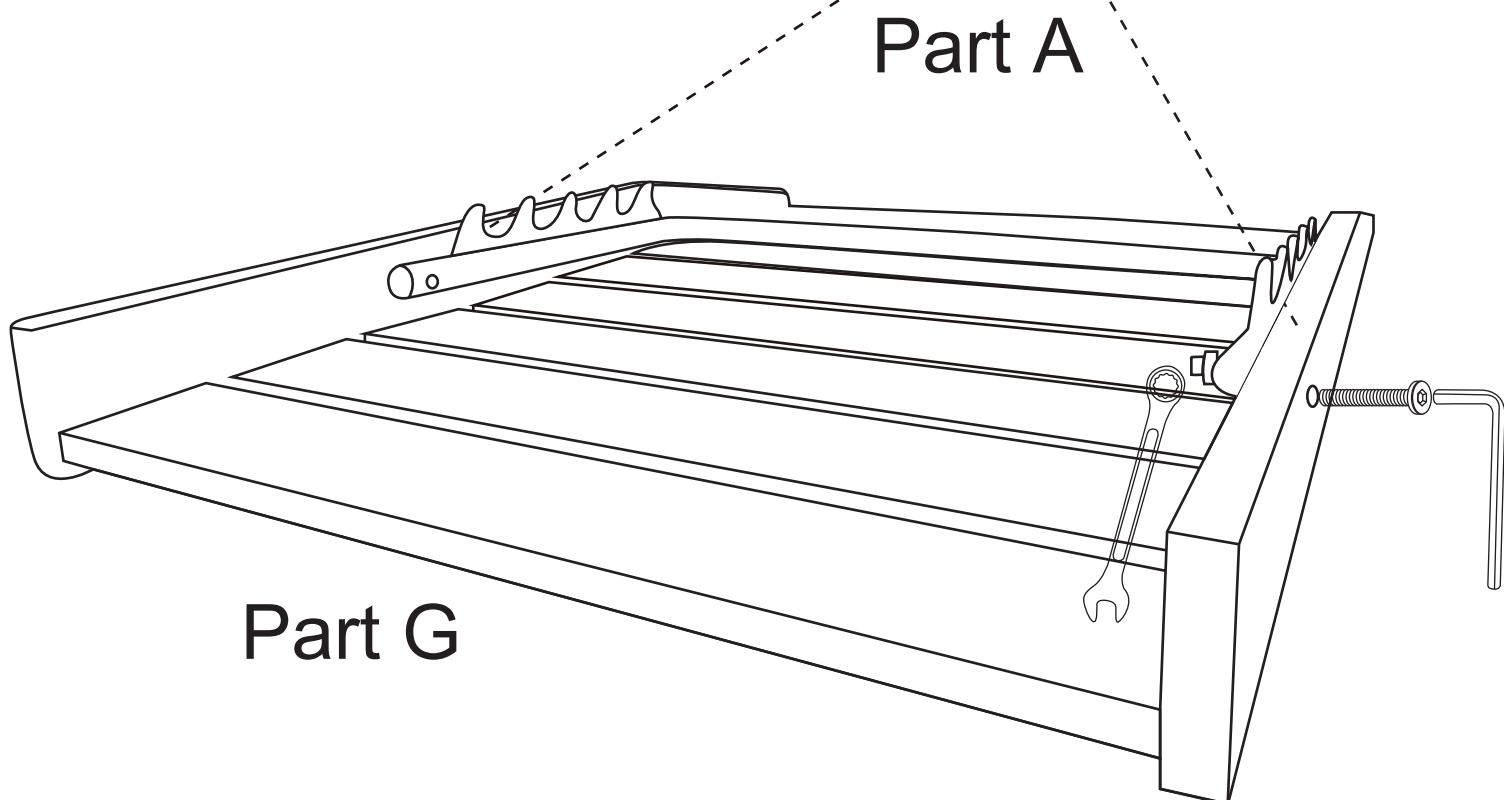
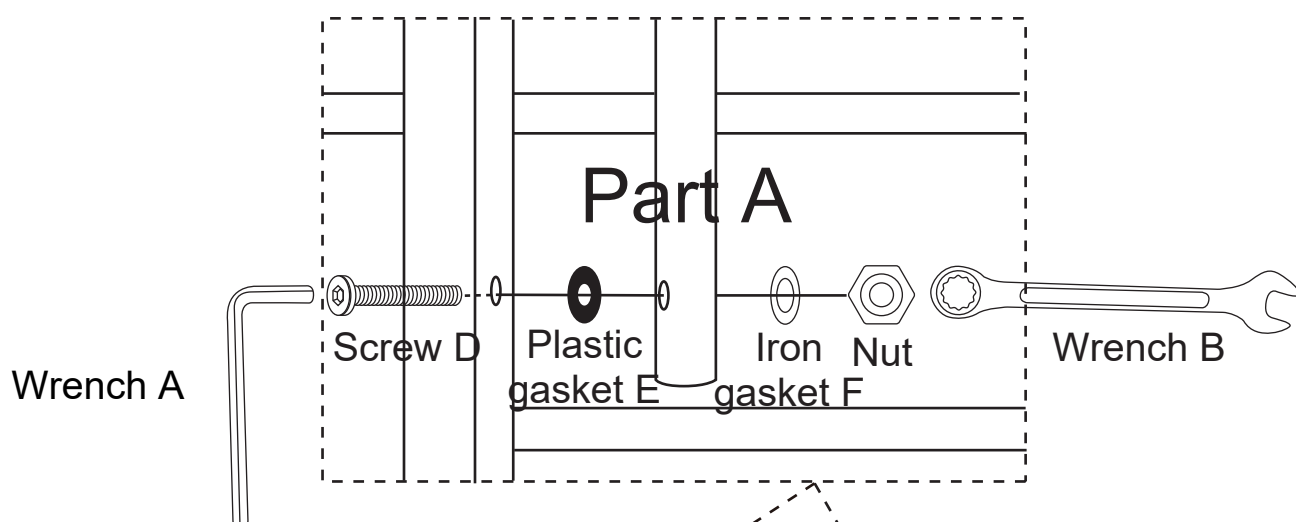
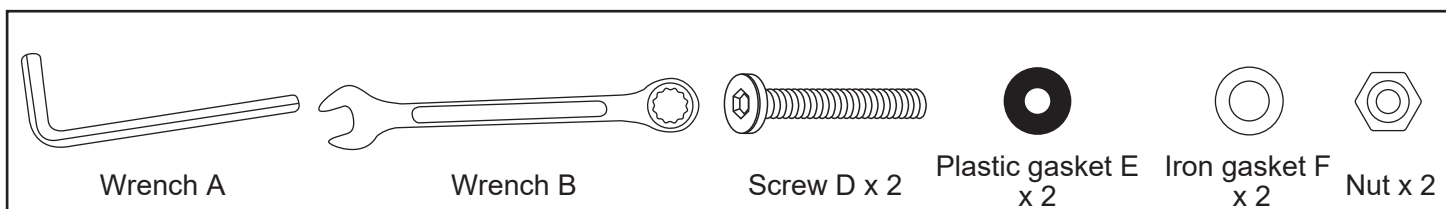

Step 6:

Finally, install Part A x 1 on Part B (1) x 1 and Part B (2) x 1, using Screw A x 2, Plastic gasket E x 2 and Iron gasket F x 2 (As shown in the figure below)

PS: Please note that Screw A is a non-slip Screw. Use a Wrench to clamp the Nut and then tighten it with a hexagon Wrench.

