

Ax1

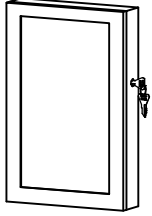

Bx2



Cx2

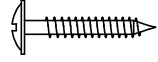

①

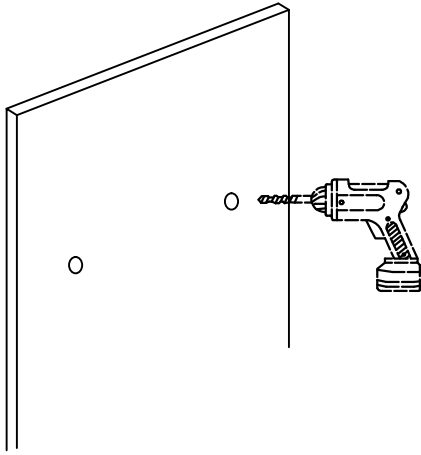

②

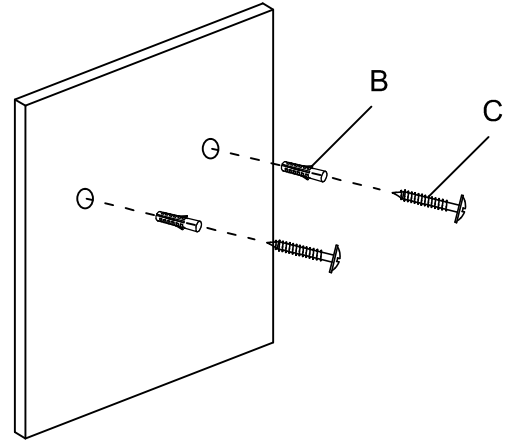

③

