

ASSEMBLY INSTRUCTIONS
COASTER FINE FURNITURE



Fine Furniture for every stage of life

701702
TV CONSOLE

ITEM: 701702



ASSEMBLY INSTRUCTIONS

ASSEMBLY TIPS:

1. Remove hardware from box and sort by size.
2. Please check to see that all hardware and parts are present prior to start of assembly.
3. Please follow attached instructions in the same sequence as numbered to assure fast & easy assembly.



WARNING!

1. Don't attempt to repair or modify parts that are broken or defective. Please contact the store immediately.
2. This product is for home use only and not intended for commercial establishments.



ASSEMBLY TIME

40 MINUTES

MAX TV SIZE : 65"

PARTS IDENTIFICATION







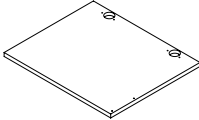
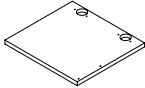
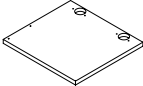

A	LEFT SIDE PANEL		1 PC	G	ADJUSTABLE PANEL		2 PCS
B	RIGHT SIDE PANEL		1 PC	H	TOP PANEL		1 PC
C	LEFT DIVIDER PANEL		1 PC	I	BACK PANEL		2 PCS
D	RIGHT DIVIDER PANEL		1 PC	J	UPPER BACK PANEL		1 PC
E	BOTTOM PANEL		1 PC	K	LOWER BACK PANEL		1 PC
F	CROSS PANEL		1 PC	L	LARGE LEFT DOOR		1 PC

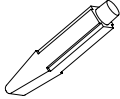
NOTE:

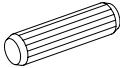
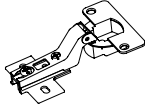
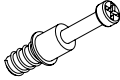
Phillips head screw driver is required in the assembly process; however, manufacturer does not provide this item.

M	LARGE RIGHT DOOR		1 PC	O	SMALL RIGHT DOOR		1 PC
N	SMALL LEFT DOOR		1 PC				

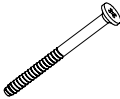
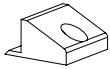
HARDWARE IDENTIFICATION

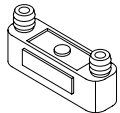
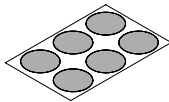
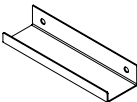
Z	NO	DESCRIPTION	FIGURE	Q'TY	NO	DESCRIPTION	FIGURE	Q'TY
	1	GLUE 15g		1 PC	9	HANDLE SCREW ø3x15mm BLK		8 PCS
	2	WOODEN DOWEL ø8x30mm		20 PCS	10	HINGE ø35mm SR		8 SET
	3	CAM BOLT ø7x35.5mm SR		12 PCS	11	HINGE SCREW ø4x15mm SR		32 PCS
	4	CAM LOCK ø15x12mm SR		12 PCS	12	FOOT ø35xH19mm		6 PCS
	5	BOLT ø9.5x55mm SR		8 PCS	13	FIXER		6 PCS
	6	PIN FOR ADJUSTABLE SHELF ø4.9x8mm SR		8 PCS	14	FIXER SCREW ø3x19mm SR		6 PCS
	7	DOOR CATCH		3 PCS	15	STICKER ø20mm		2 PCS
	8	HANDLE L=120mm BLK		4 PCS				

Z8,Z10,Z12 not included in blister packaging.

NOTE:

Phillips head screw driver is required in the assembly process; however, manufacturer does not provide this item.

ITEM: 701702

STEP 1

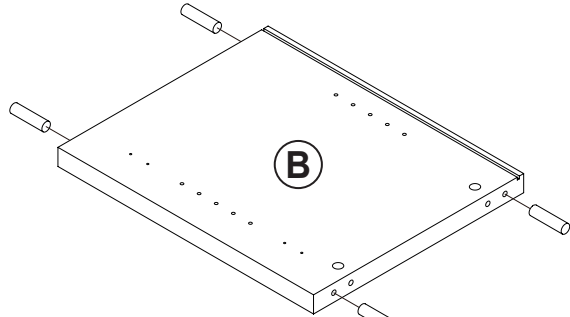
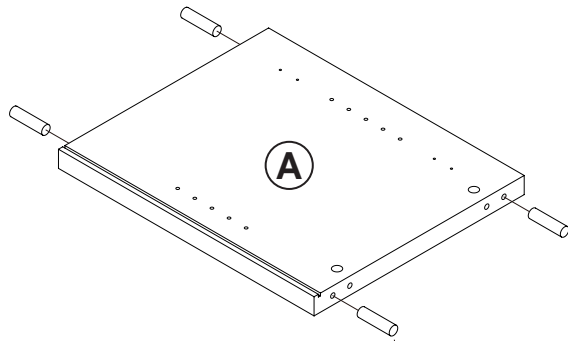
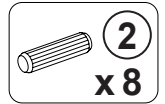

INCORRECT
CORRECT

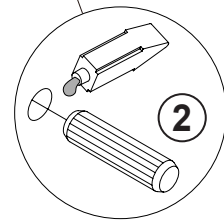
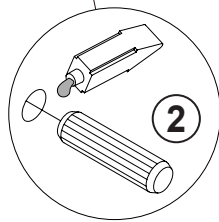
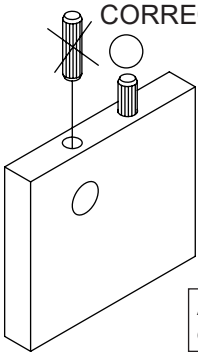

Apply glue on all wooden dowels to ensure integrity of the structure.

STEP 2

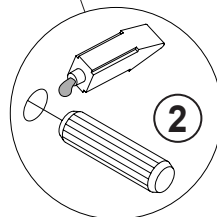
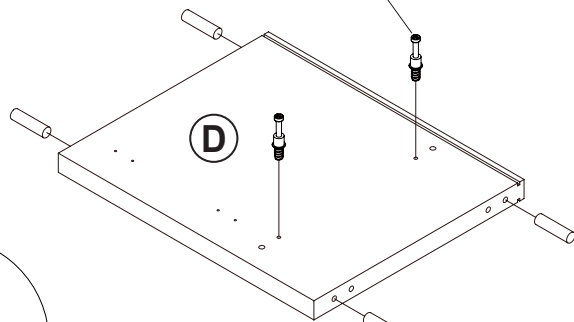
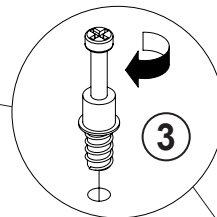
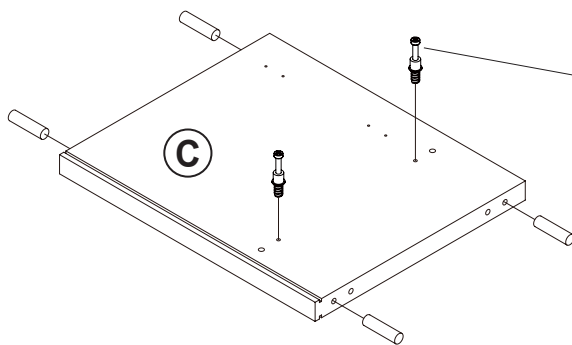
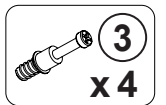
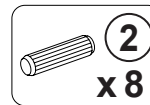

ITEM: 701702

COASTER
FINE FURNITURE

STEP 3

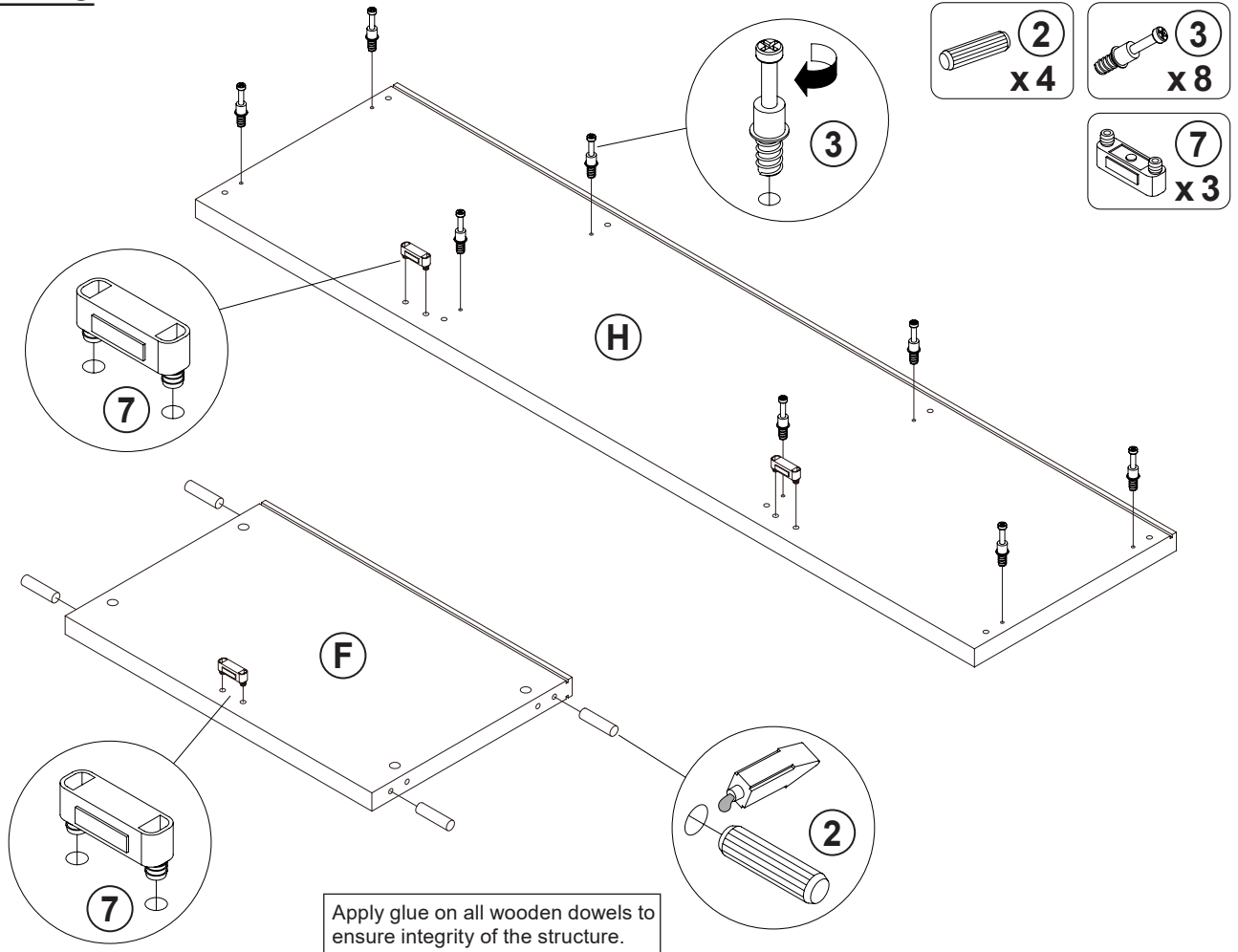

STEP 4

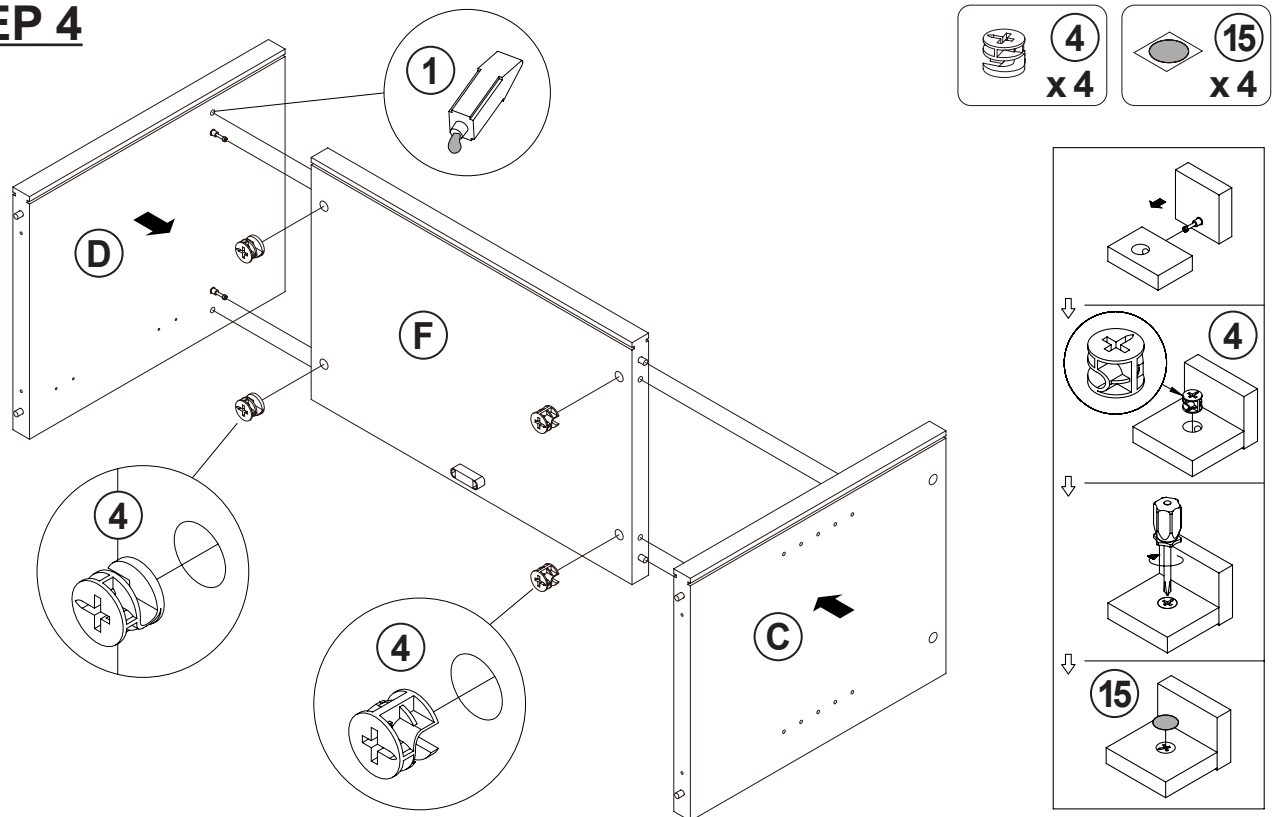

ITEM: 701702

STEP 5

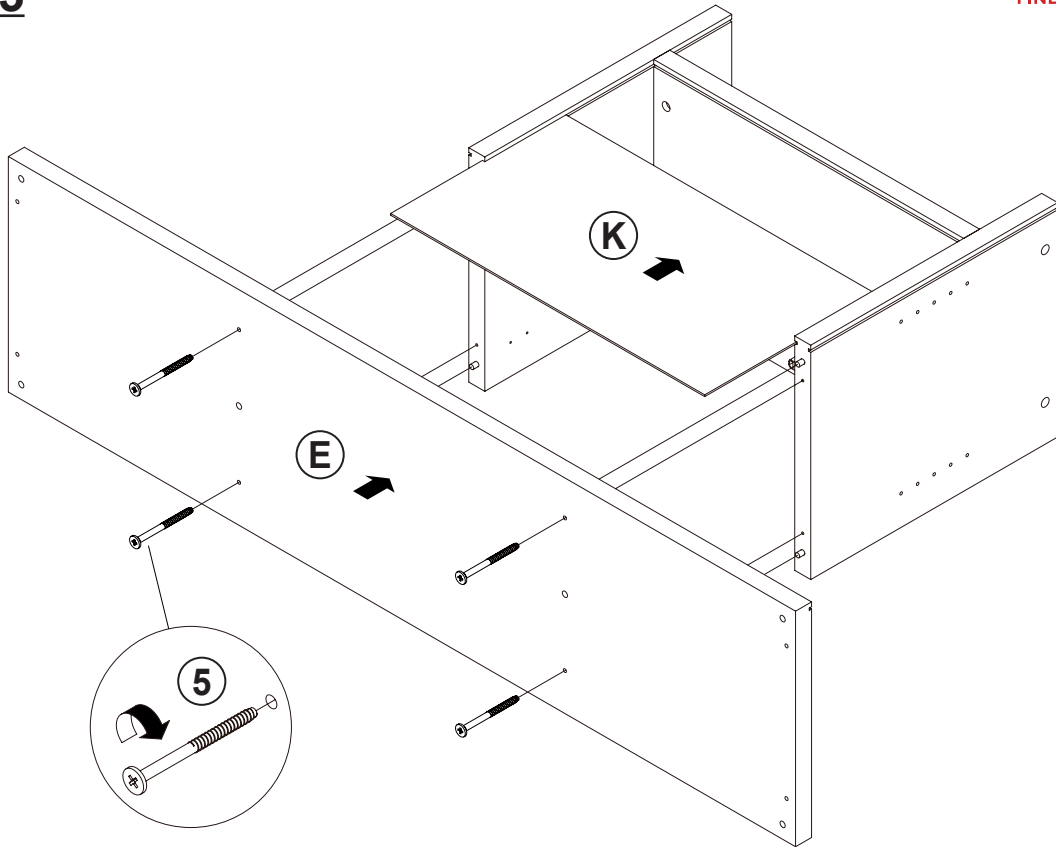
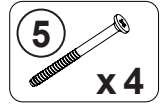

STEP 6

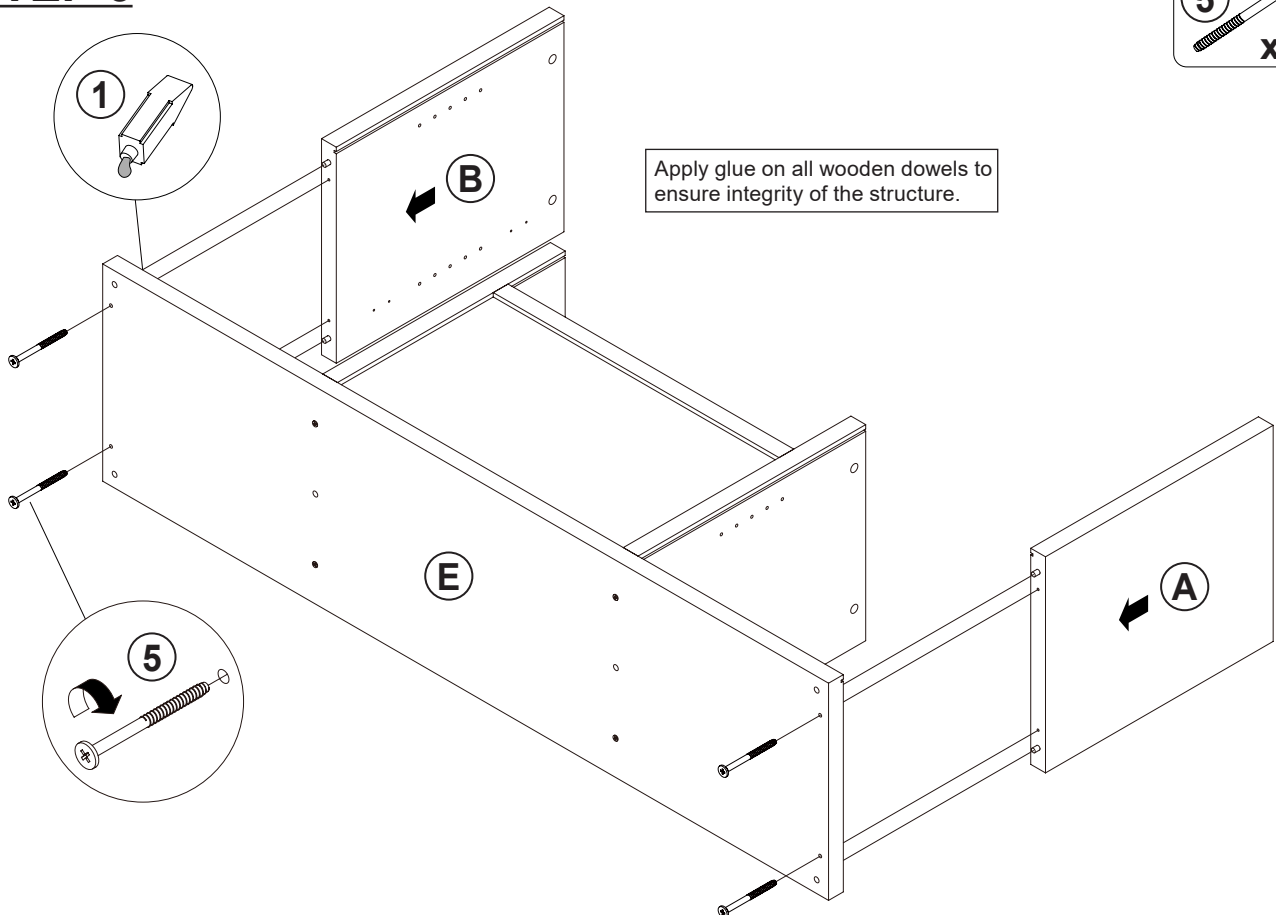
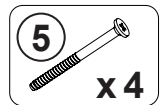

ITEM: 701702

COASTER[®]

FINE FURNITURE

STEP 7

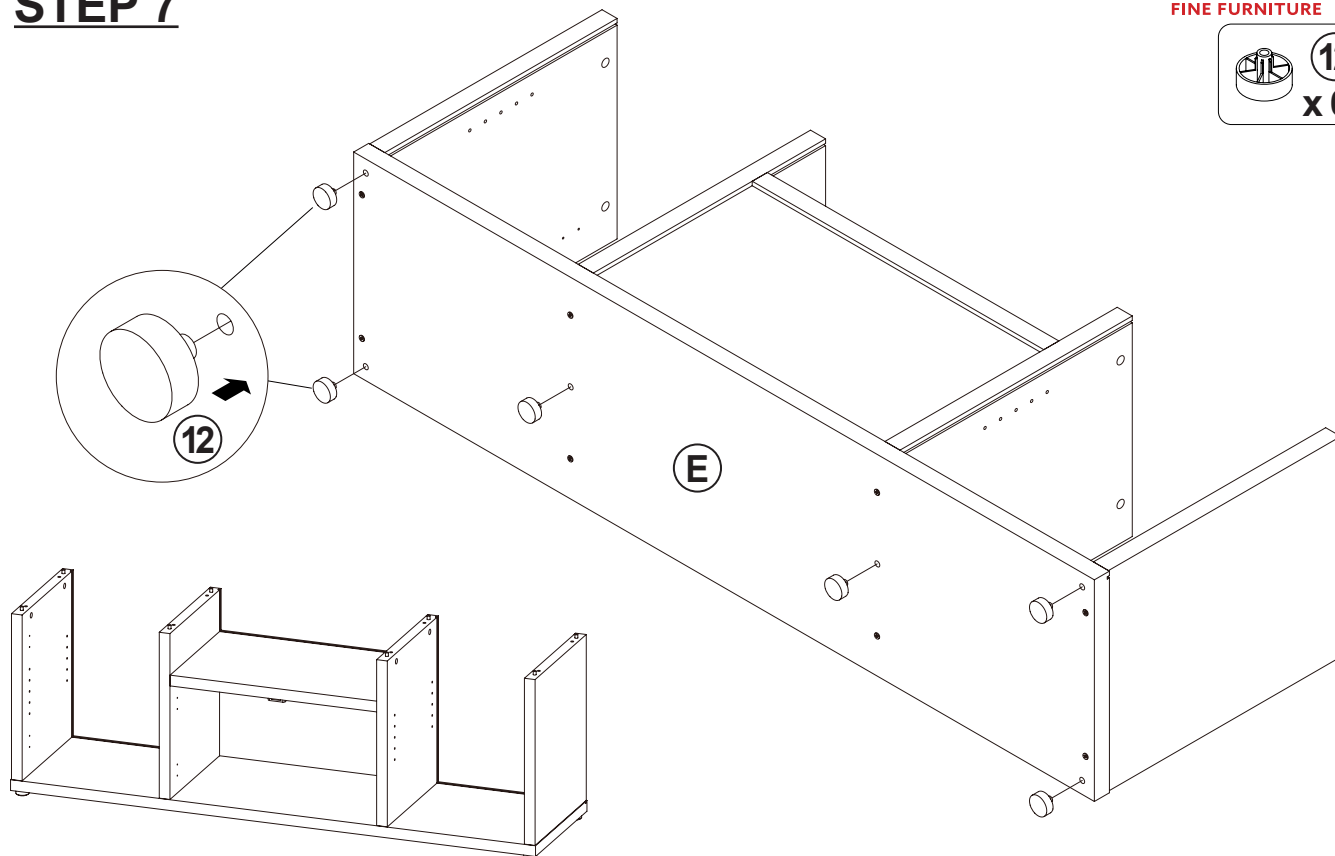
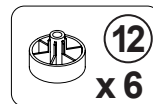

STEP 8

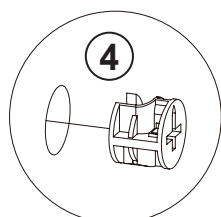
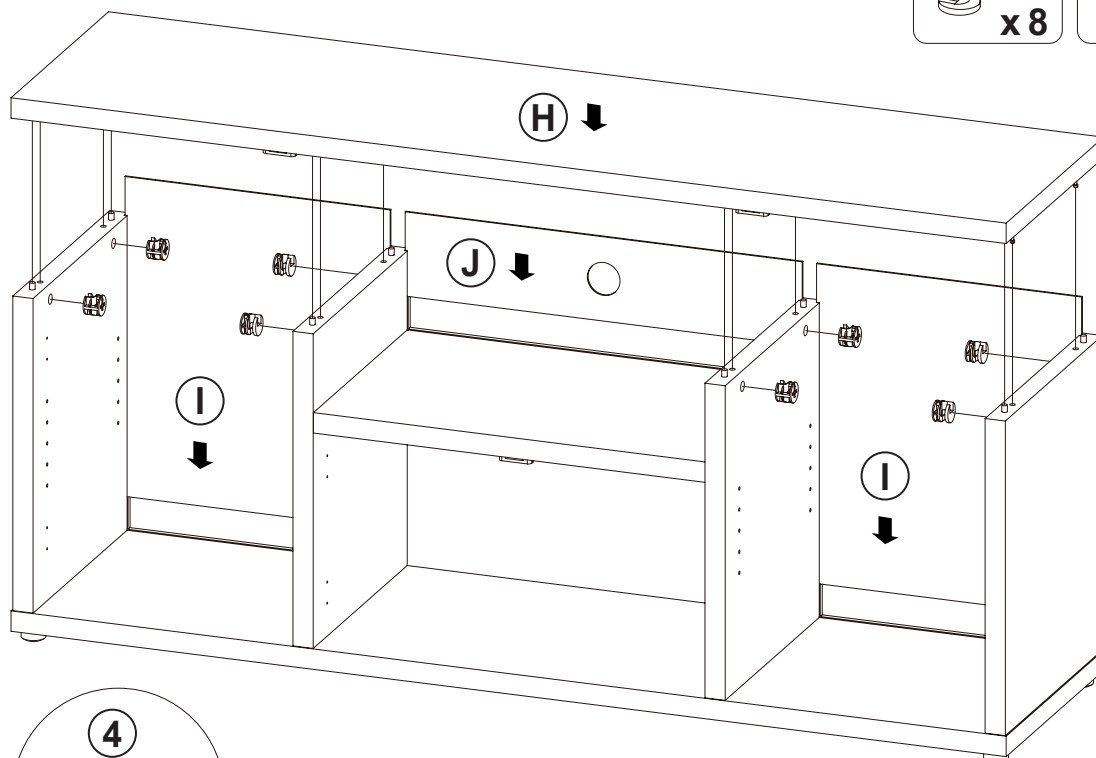
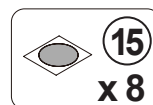

ITEM: 701702

COASTER[®]

FINE FURNITURE

STEP 9

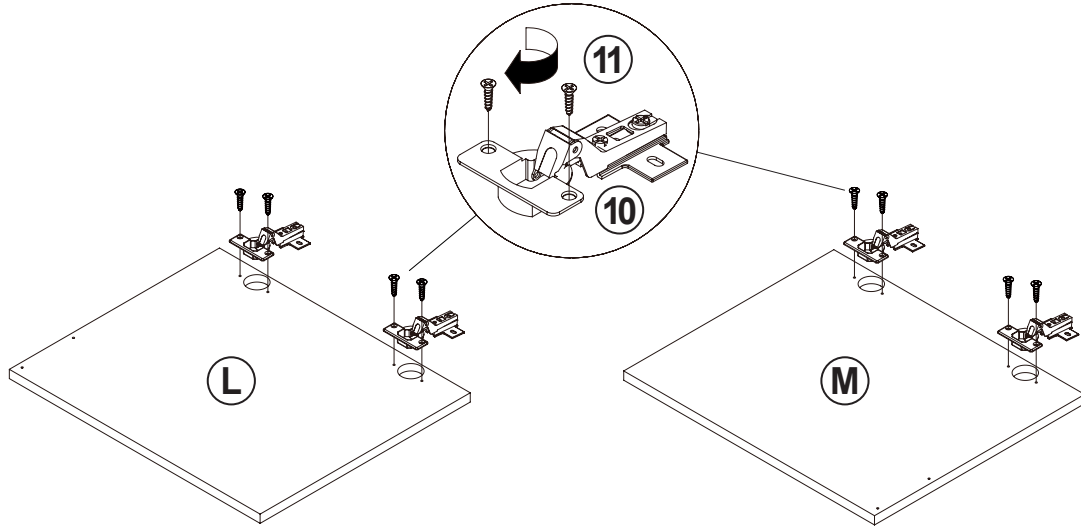
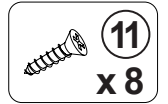
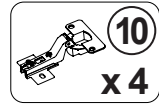

STEP 10

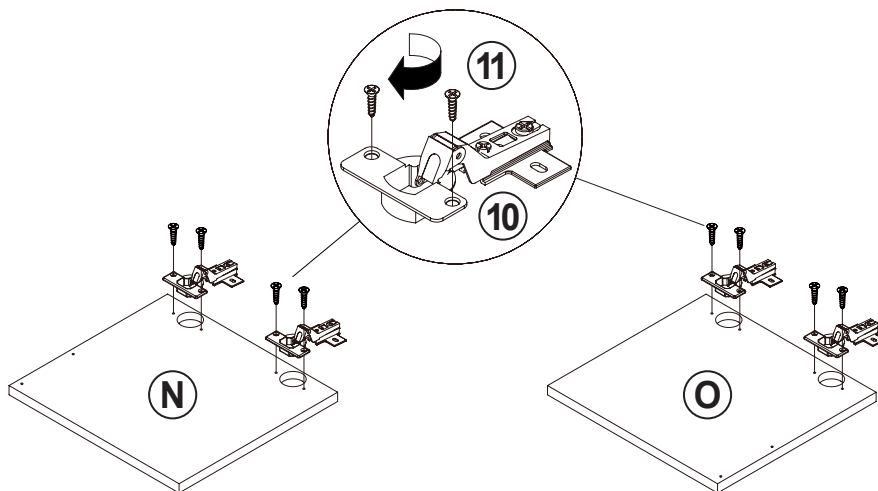
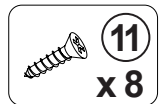
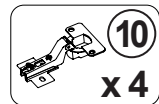

ITEM: 701702

COASTER
FINE FURNITURE

STEP 11

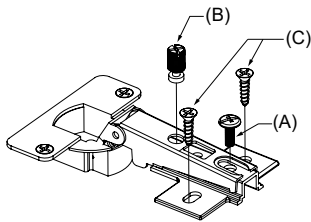
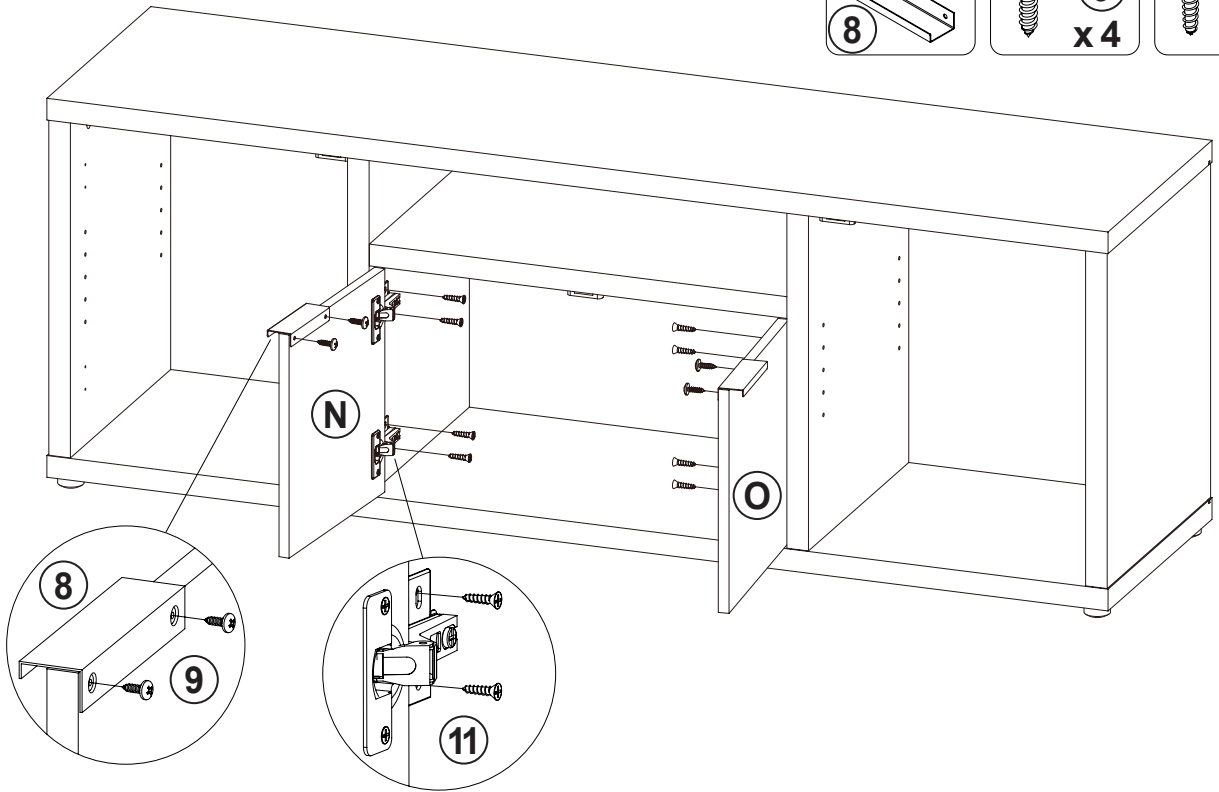
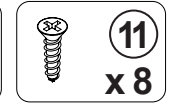
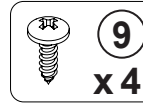
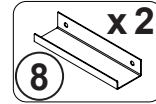

HORIZONTAL BY
SCREW A ADJUSTMENT

LATERAL BY
SCREW B ADJUSTMENT

VERTICAL BY
SCREW C ADJUSTMENT

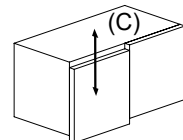
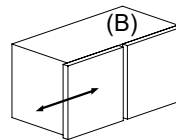
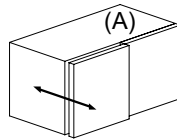

STEP 12

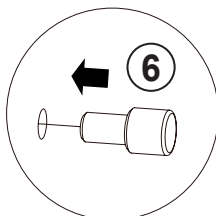
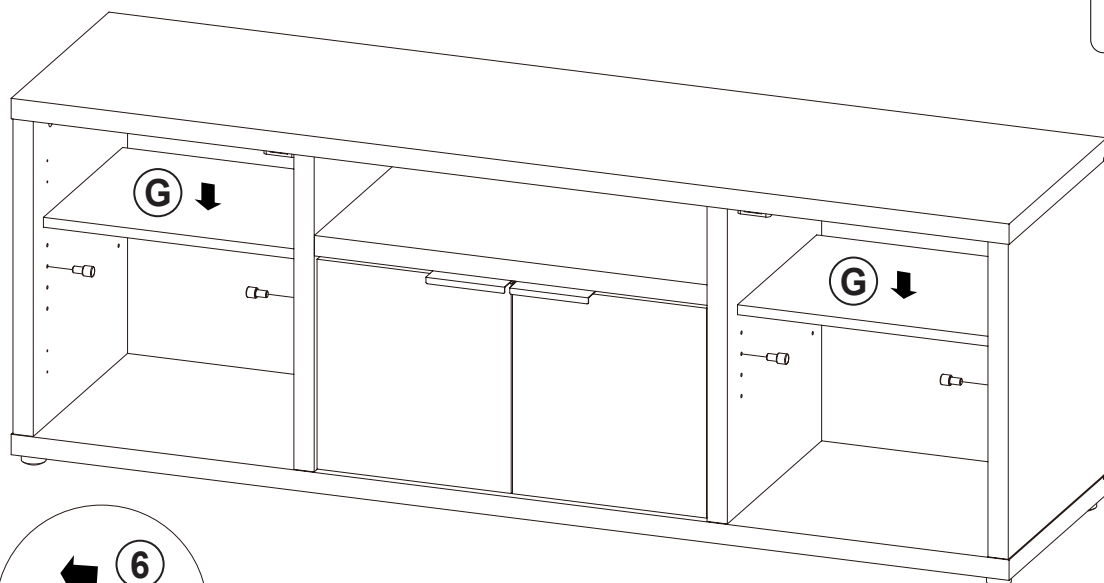
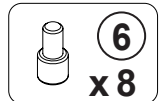

ITEM: 701702

COASTER
FINE FURNITURE

STEP 13

- 8 x 2
- 9 x 4
- 11 x 8

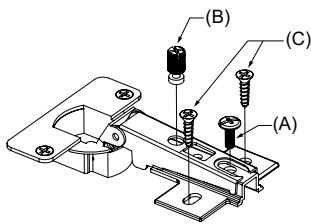
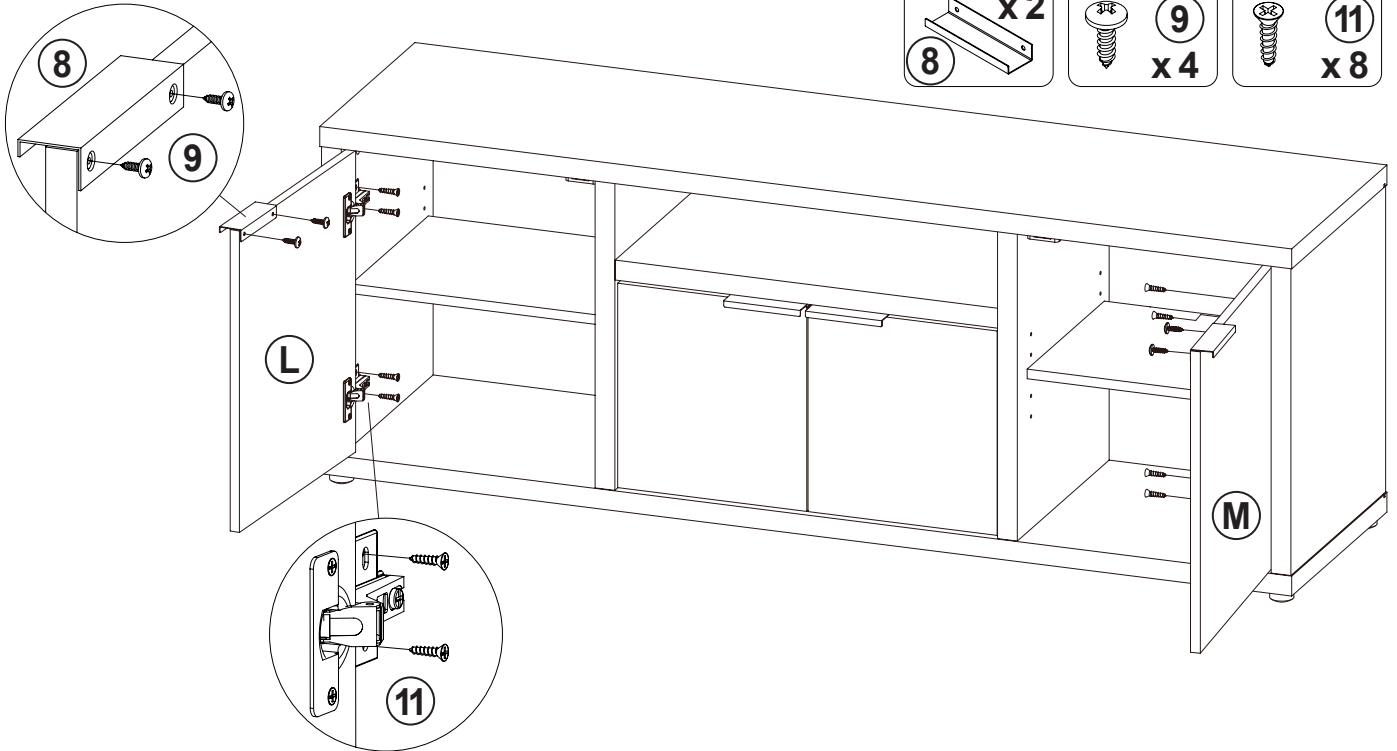

HORIZONTAL BY
SCREW A ADJUSTMENT

LATERAL BY
SCREW B ADJUSTMENT

VERTICAL BY
SCREW C ADJUSTMENT

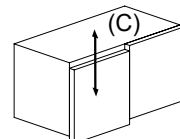
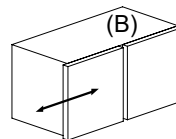
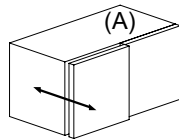

STEP 14

- 13 x 6
- 14 x 6

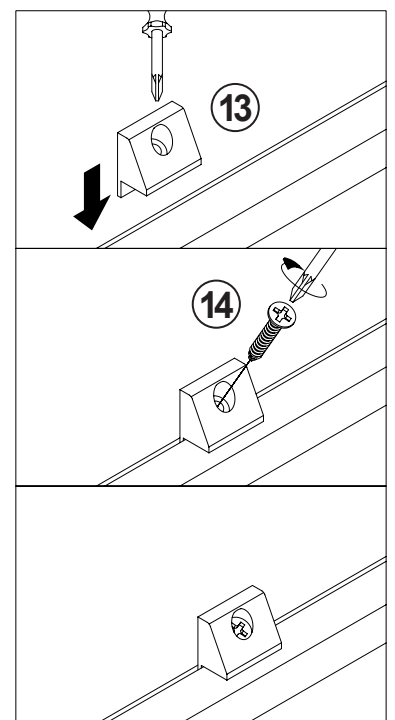
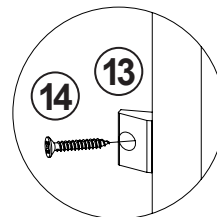
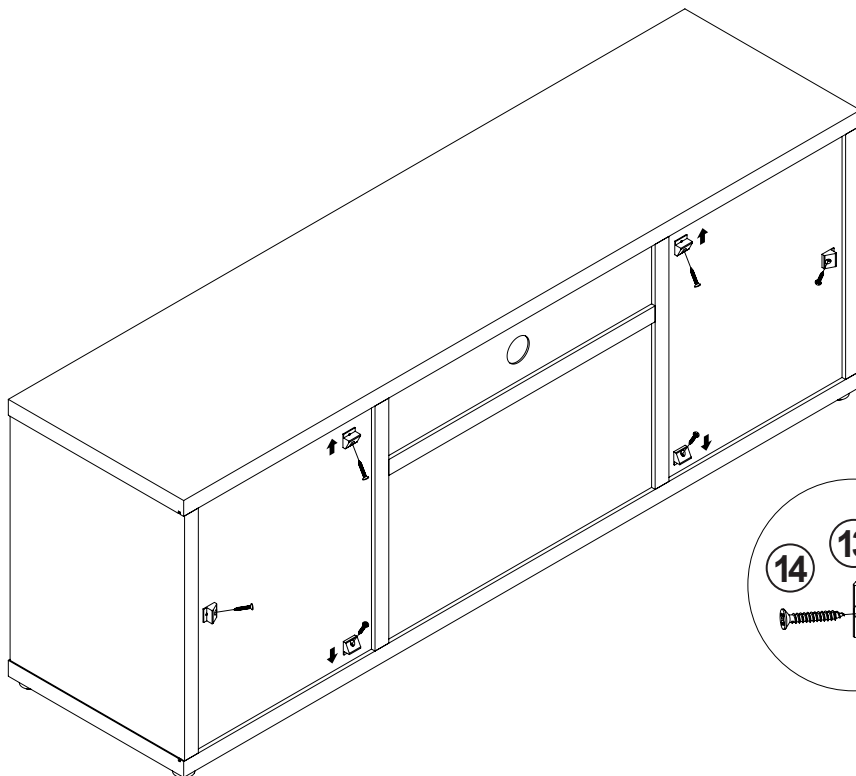

ITEM: 701702

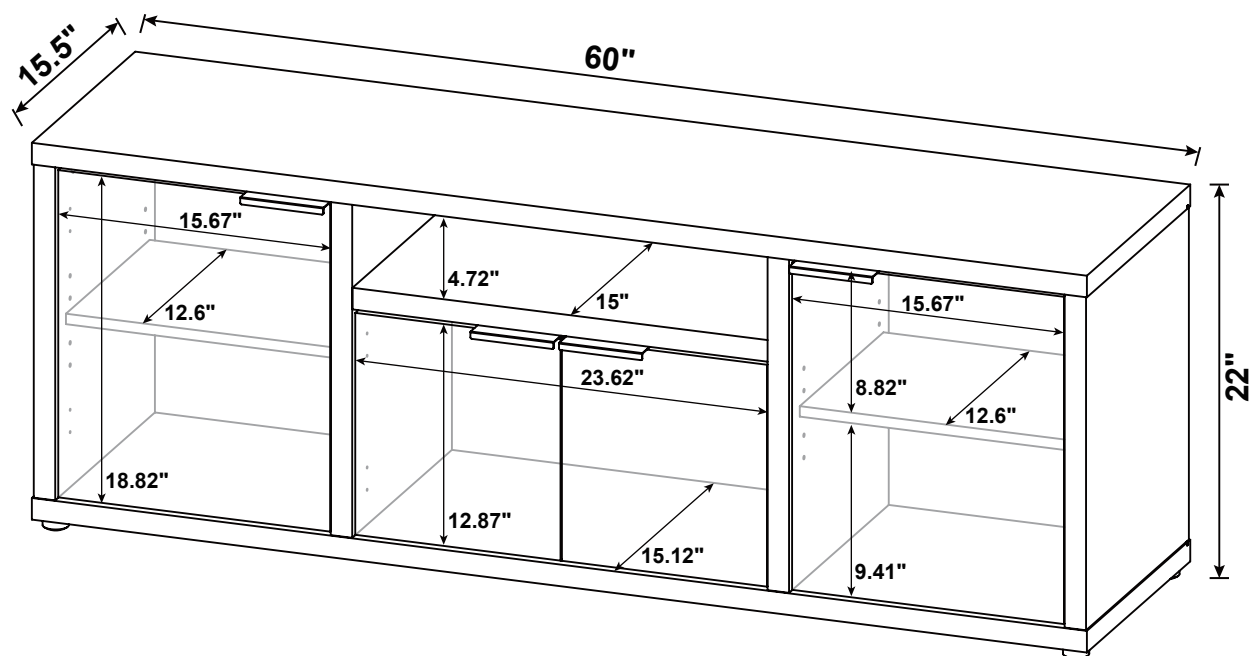

Note : Dimension tolerance $\pm 5\%$