

MANUAL INSTRUCTION

Fireplace TV cabinet

Warm Tips: 2 Box Delivery- The TV stand and electric fireplace are shipped in 2 separate packages. If you have received one package, please rest assured — The other is on its way!

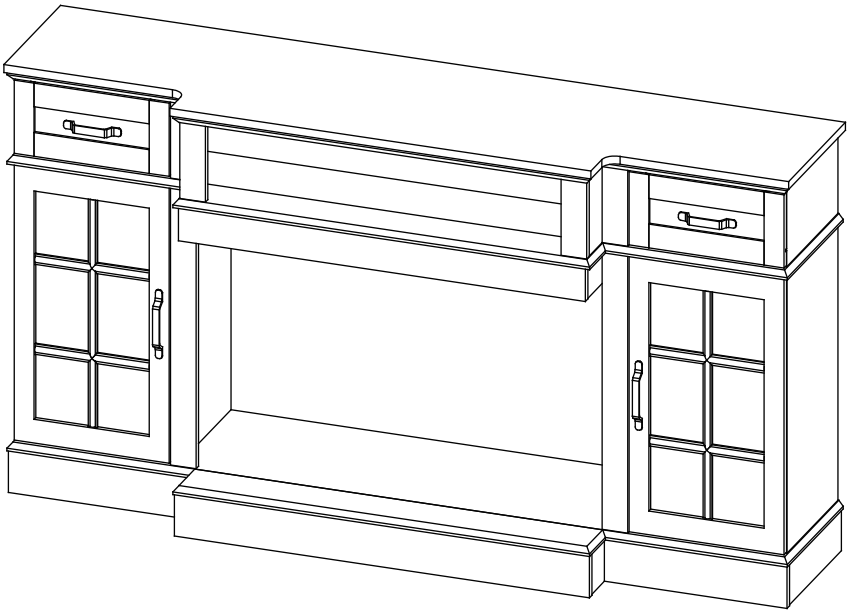

Fireplace TV cabinet



We offer a diverse range of products
to meet the needs of customers.

Reach us at

 service@kmcglobe-us.com

 (+1) 559-354-1889

Some Notes From KMC Group

1. The product must be assembled and used in accordance with the provisions of the manual. The seller does not assume any responsibility or liability with respect to any damage caused by incorrect assembly or improper use.
2. Periodically inspect screw tightness while the product is in use. If necessary, retighten to ensure structural integrity.
3. Please read assembly instructions before start.
4. Please remember : This summary may not include every detail of all variations or considered steps.
5. Please contact us when further information are needed.
- * 6. Contact Us(24/7):**service@kmcglobe-us.com**

Warnings

1. It is strictly prohibited to sit or stand on the product.
2. Please put this item on a flat ground.
3. During the assembly process, keep any small parts out of the reach of children. It may be fatal if swallowed or inhaled
4. To avoid the potential dangers of suffocation, please keep all parts and packaging (films, plastic bags and foam, etc.) away from babies and children.
5. If there is/are defective and/or missing part(s) after unpacking, please cease assembly immediately and get in contact with us as soon as possible.
- * 6. You may reach us at: **service@kmcglobe-us.com**

Tools Required

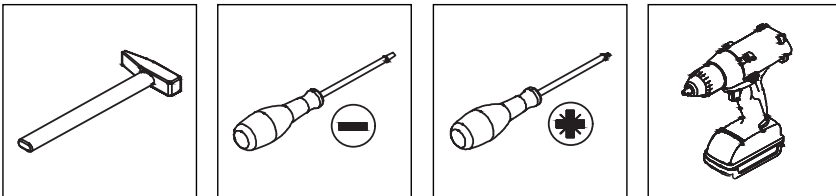

If electric tools are required, please reduce the torque to prevent product damage during installation.

PARTS

 2 Persons Assembly

 Up to 150 Minutes For Assembly



When installing, please carefully confirm whether each screw corresponds to the manual, accessories with similar shapes can be distinguished by size.

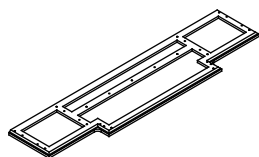

① × 1

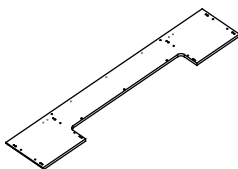

② × 1

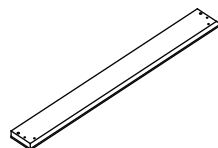

③ × 1

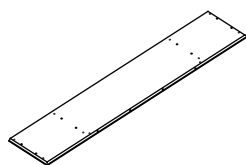

④ × 1

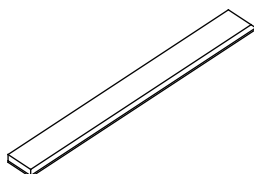

⑤ × 1

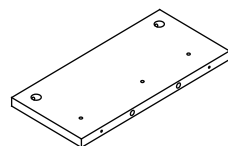

⑥ × 1

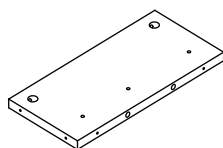

⑦ × 1

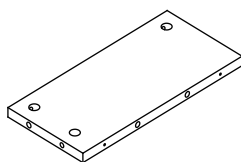

⑧ × 1

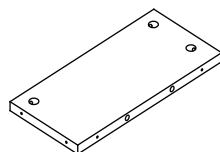

⑨ × 1

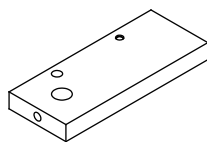

⑩ × 1

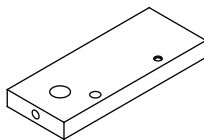

⑪ × 1

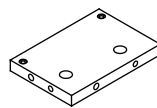

⑫ × 1

PARTS

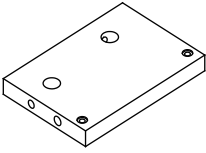

13 x 1

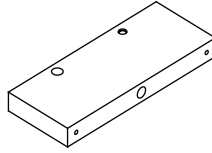

14 x 1

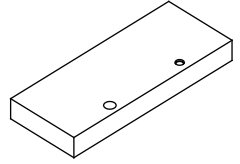

15 x 1

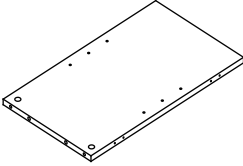

16 x 1

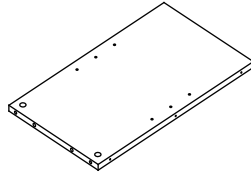

17 x 1

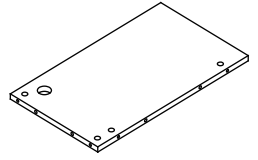

18 x 1

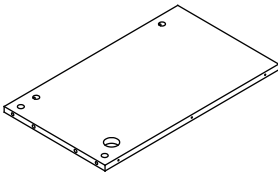

19 x 1

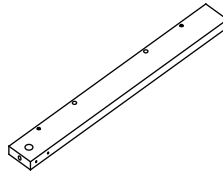

20 x 1

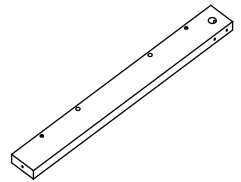

21 x 1

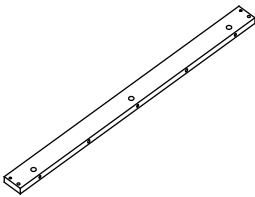

22 x 1

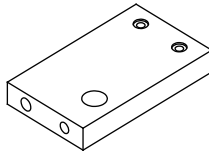

23 x 1

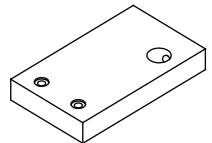

24 x 1

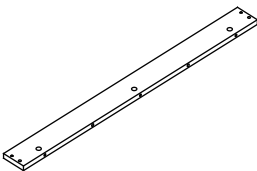

25 x 2

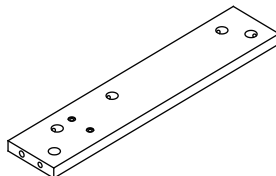

26 x 1

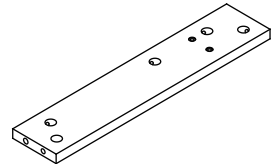

27 x 1

PARTS

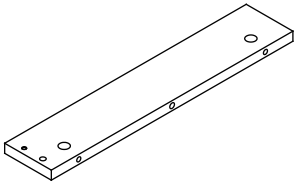

②⑧ × 1

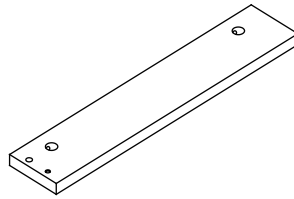

②⑨ × 1

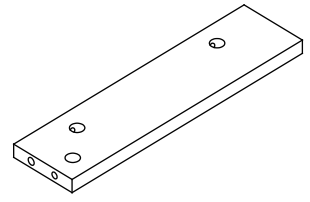

③⑩ × 1

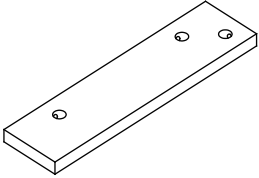

③① × 1

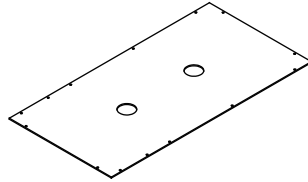

③② × 2

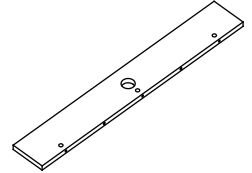

③③ × 1

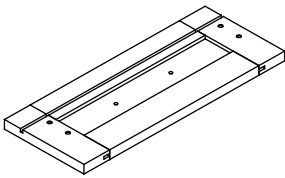

③④ × 1

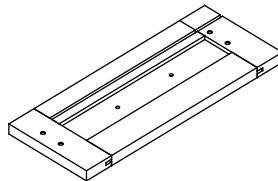

③⑤ × 1

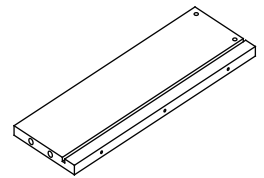

③⑥ × 2

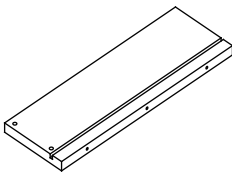

③⑦ × 2

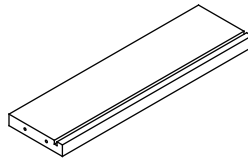

③⑧ × 2

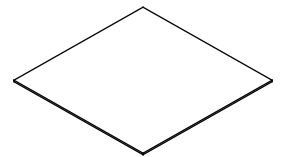

③⑨ × 2

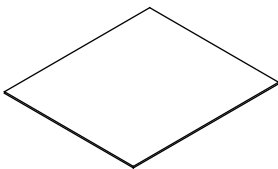

④① × 2

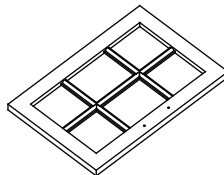

④② × 1

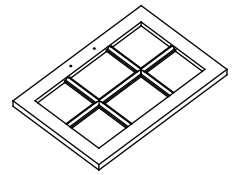

④③ × 1

HARDWARE

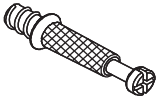

M6x35mm

A × 72+2

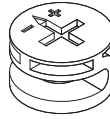

∅15x9mm

B × 72+2



∅8x30mm

C × 78+2



M4x35mm

D × 43+2

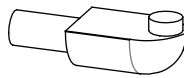

E × 8

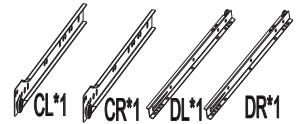

F × 2

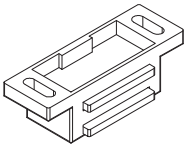

G × 2

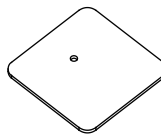

H × 2

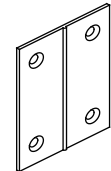

I × 4



M3.5x14mm

J × 32+2



M3.5x14mm

K × 30+2



L × 12

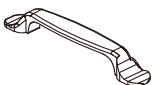

M × 4



M4x18mm

N × 4

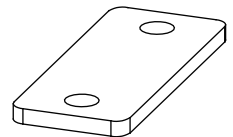

O × 6

HARDWARE



M5x14mm

P × 12+1



M4x6mm

Q × 4

I EXPLOSION DIAGRAM

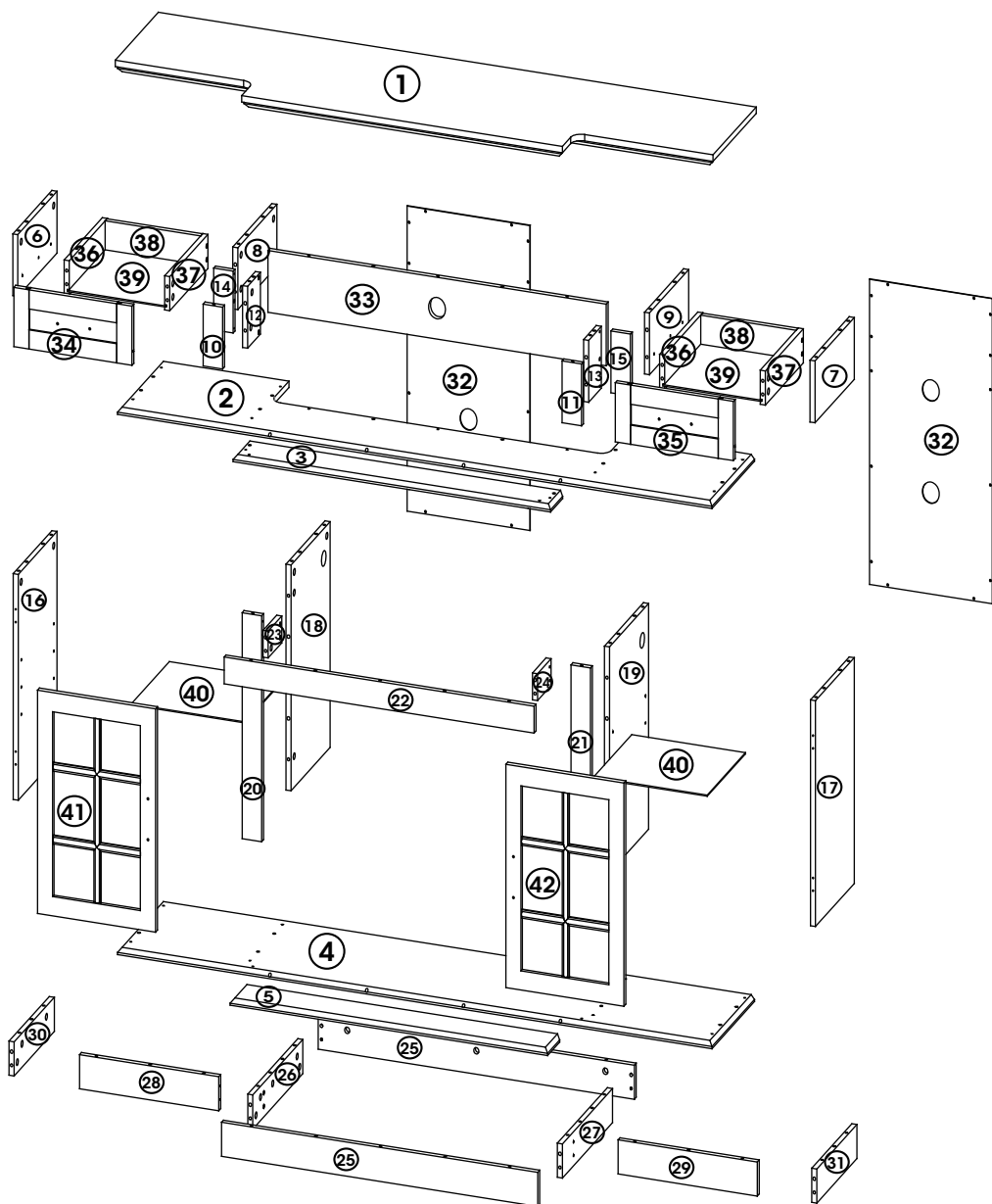

1**C** x8**G** x2**J** x4**O** x6**P** x12

Place the TV cabinet on a clean floor for installation to prevent scratching of the panels

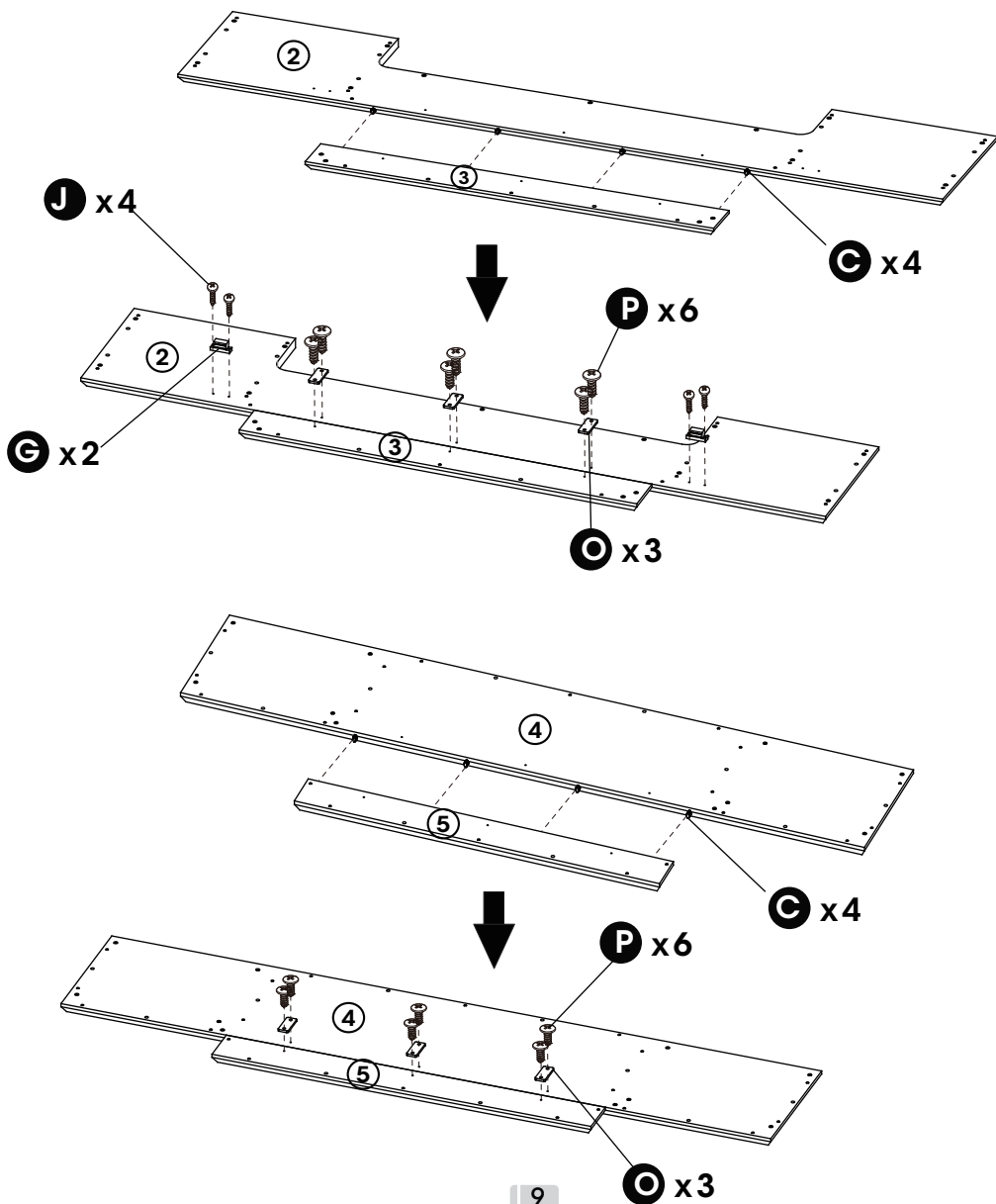

2



A x48

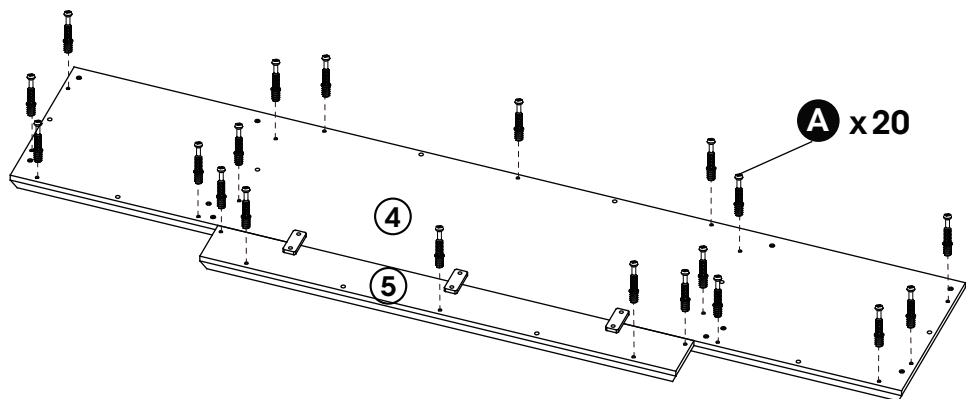
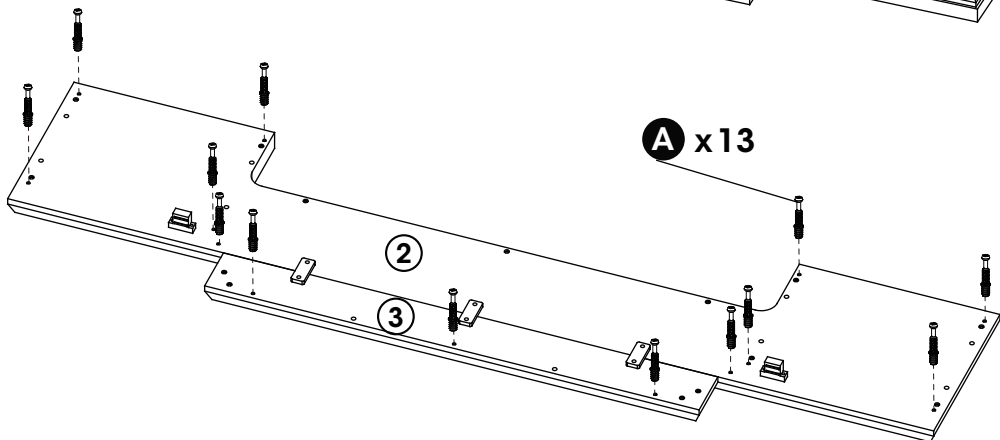
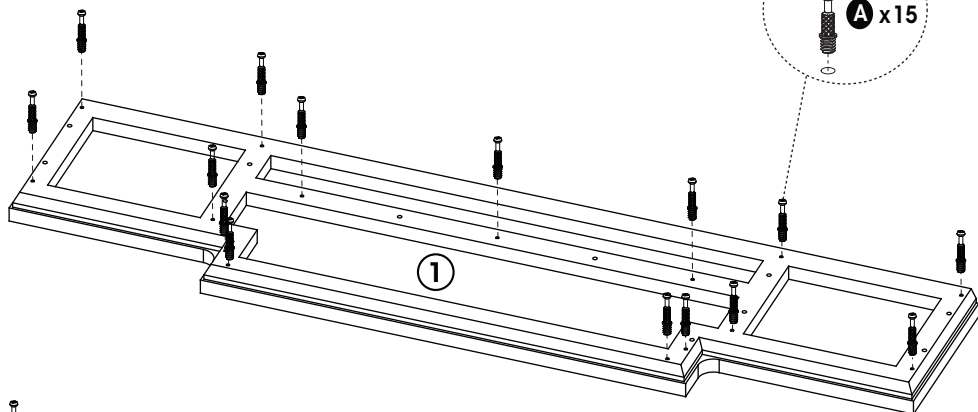
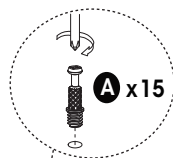

3

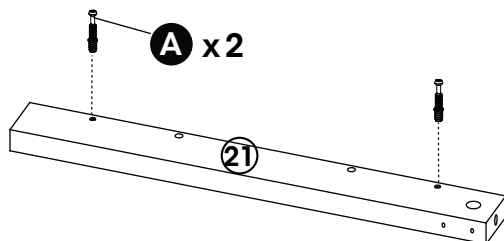
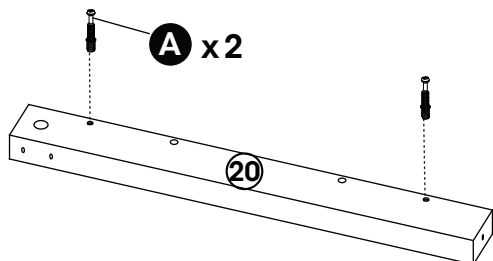
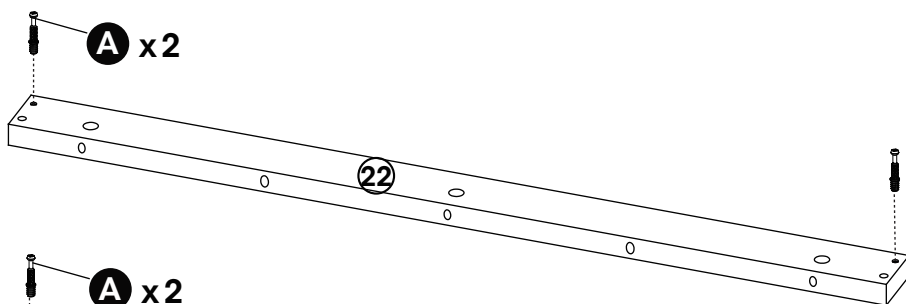
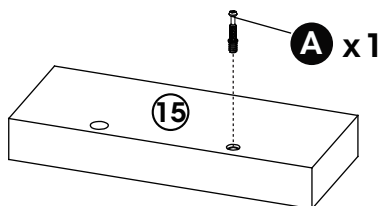
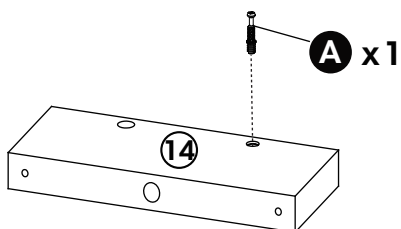
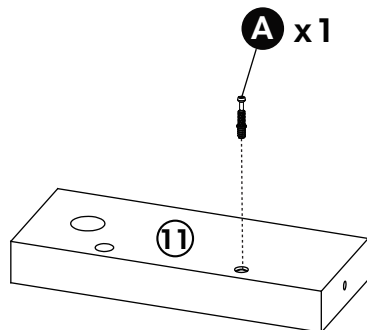
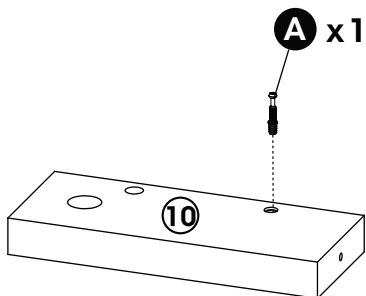

4

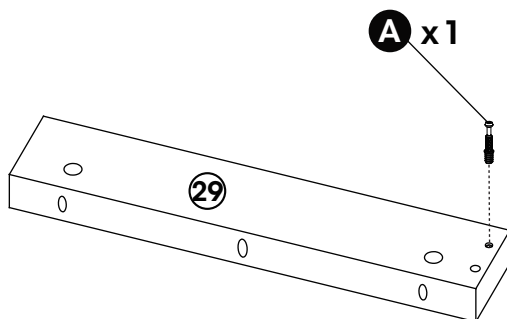
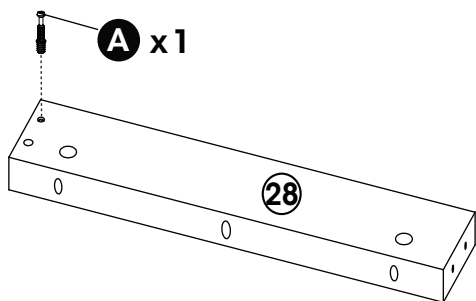
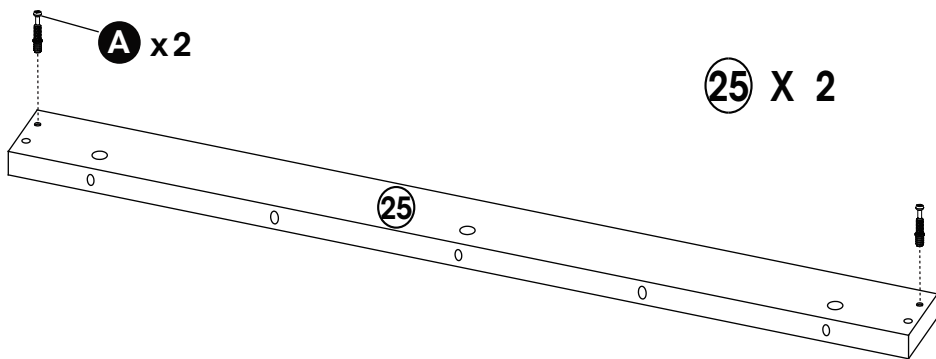

6

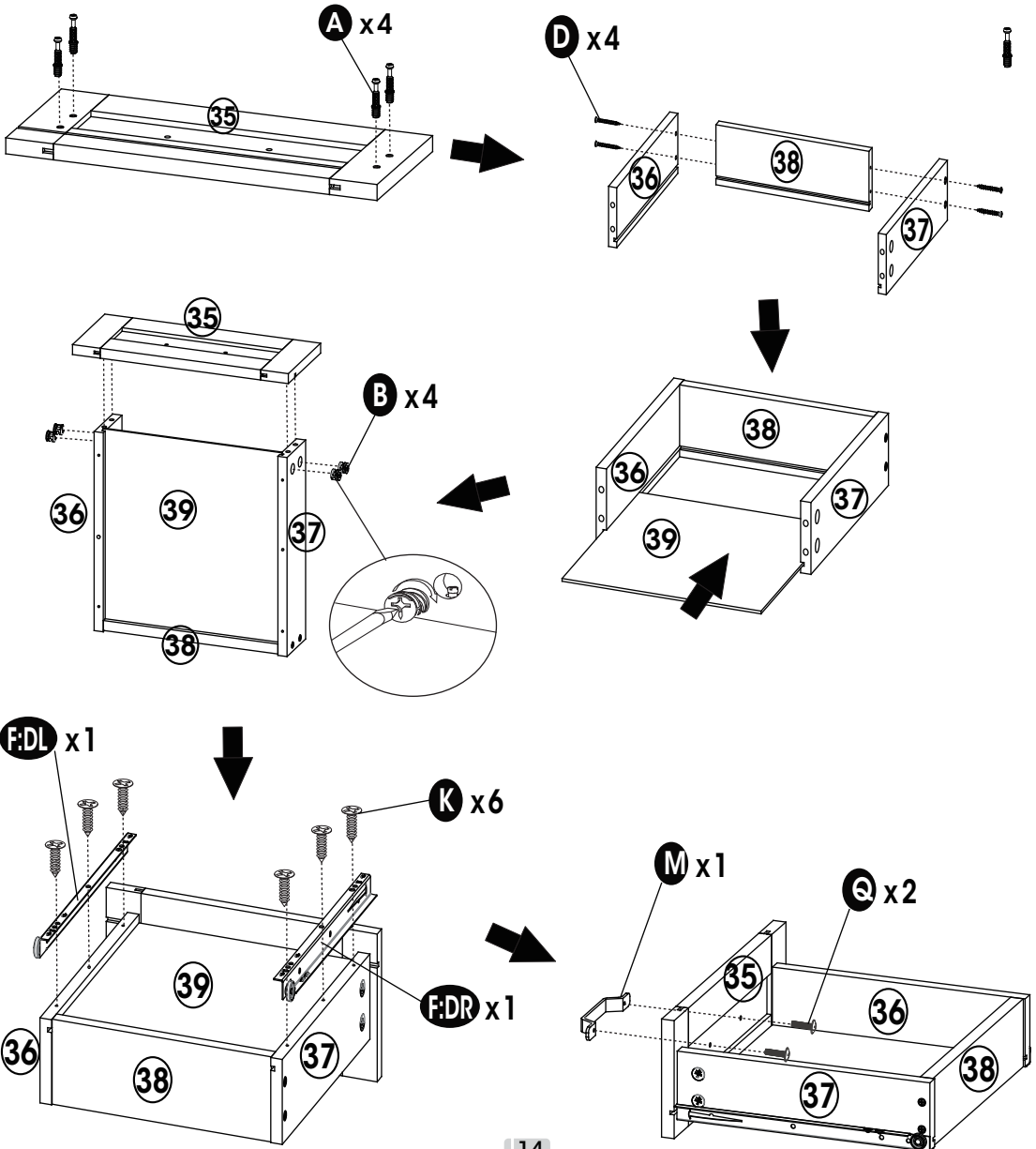
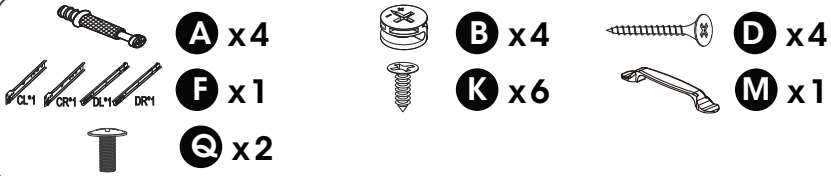

7



C x18



F x2



L x12

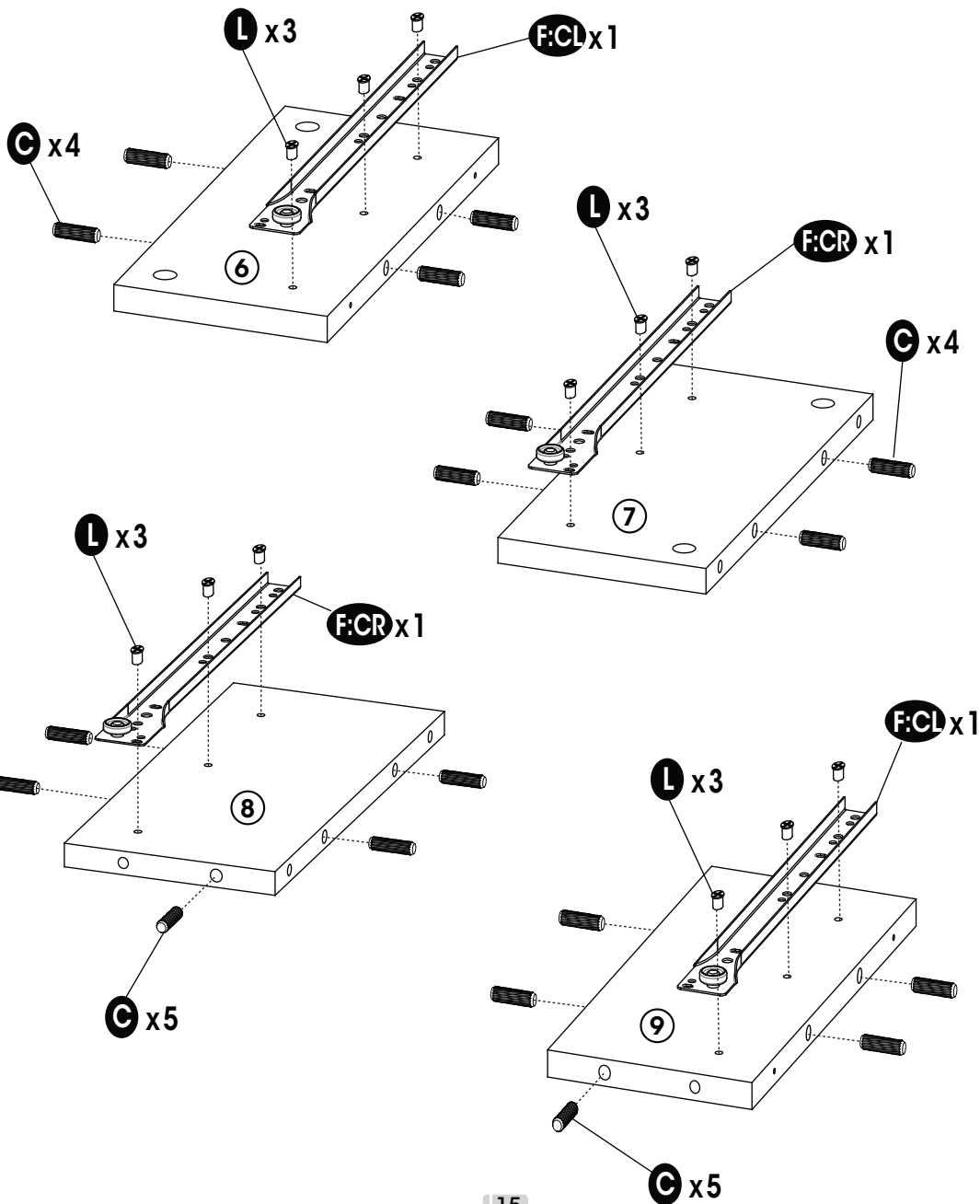

8

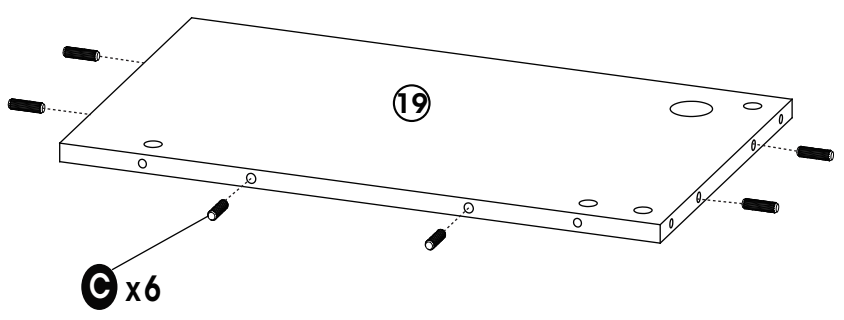
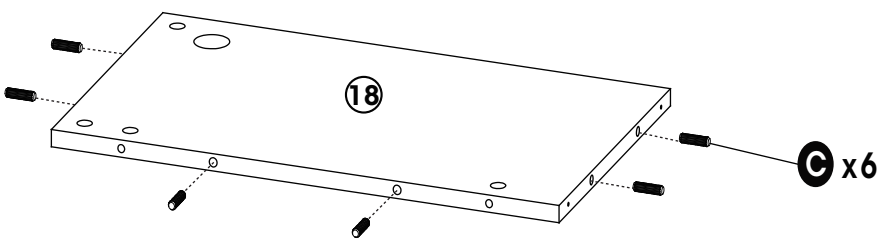
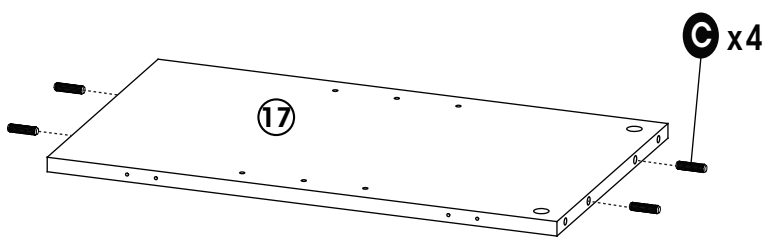
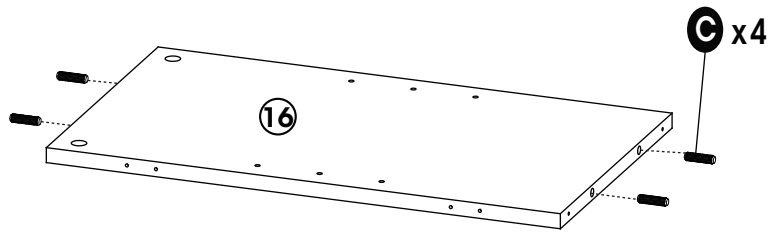
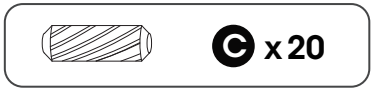

9

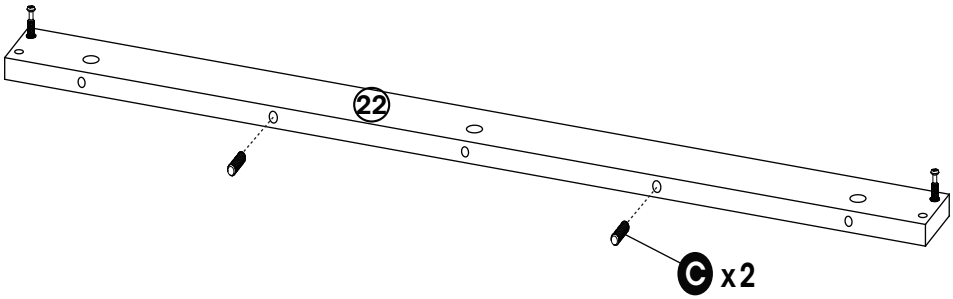
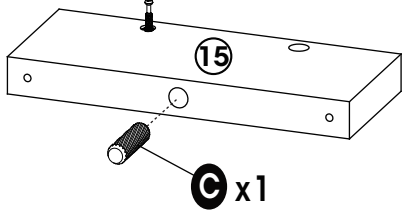
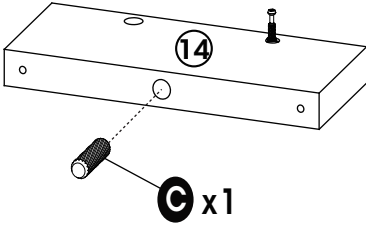
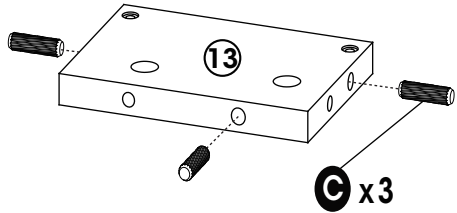
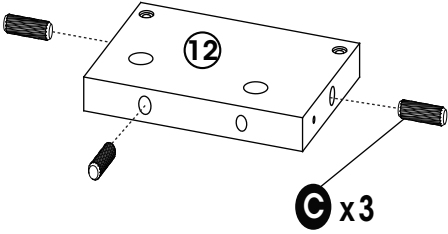
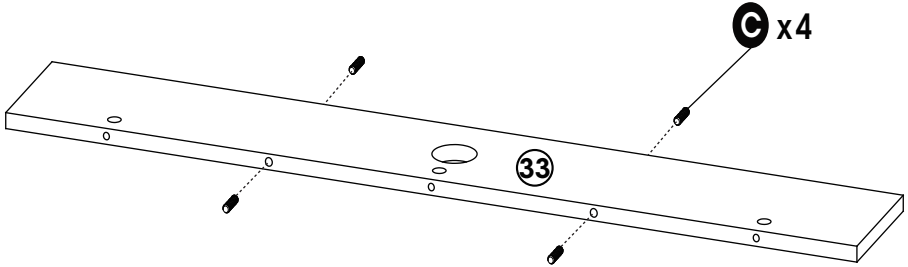

10

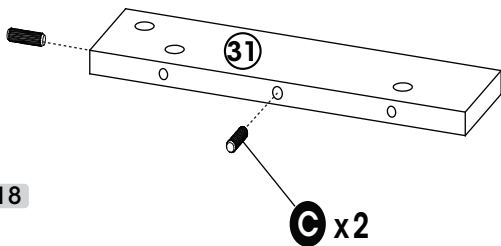
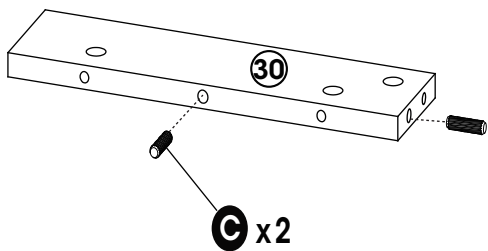
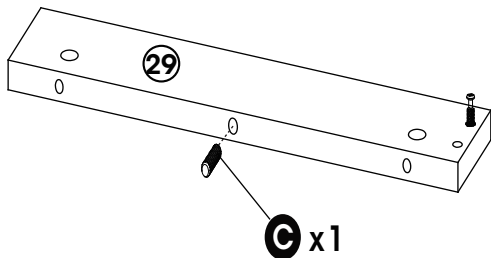
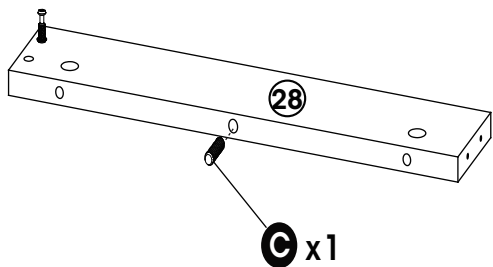
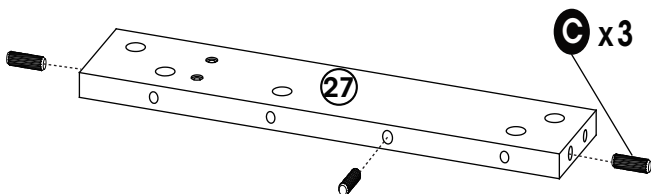
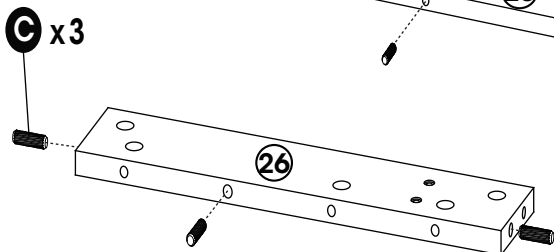
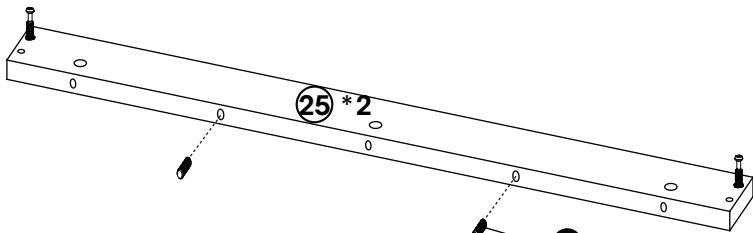
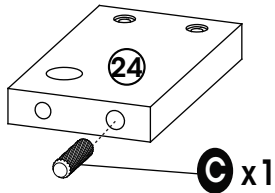
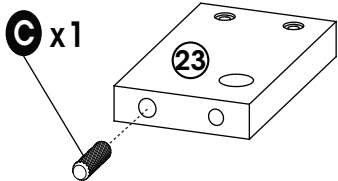
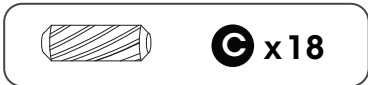

11



B x2



D x2

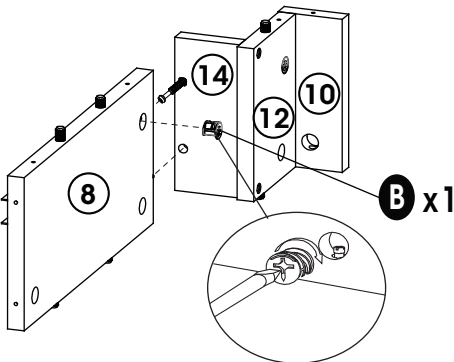
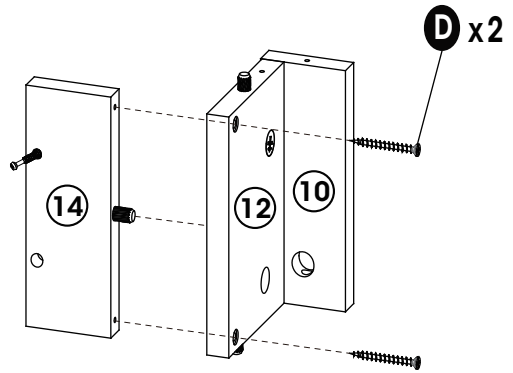
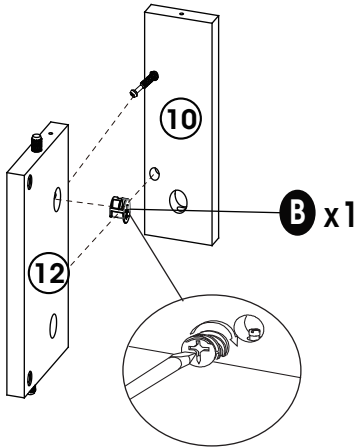

12



B x2

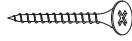

D x2

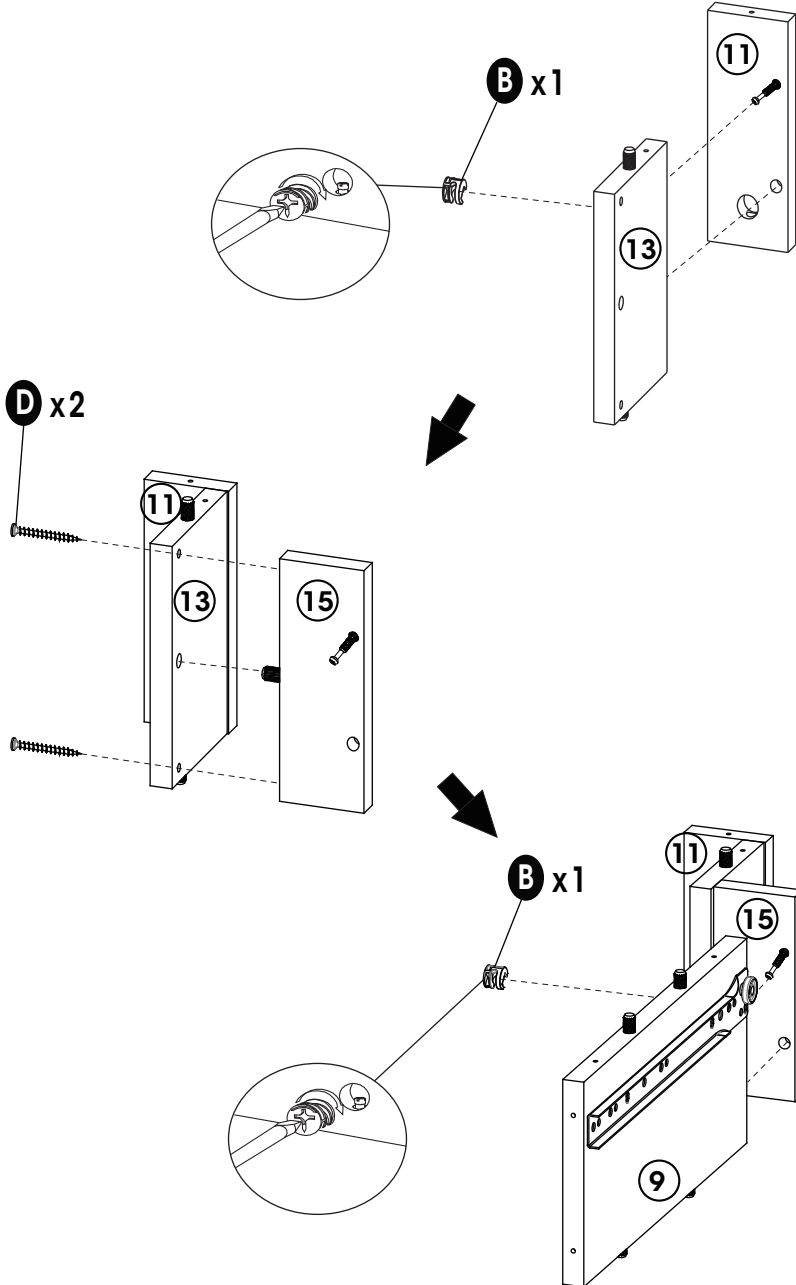

13



B x12

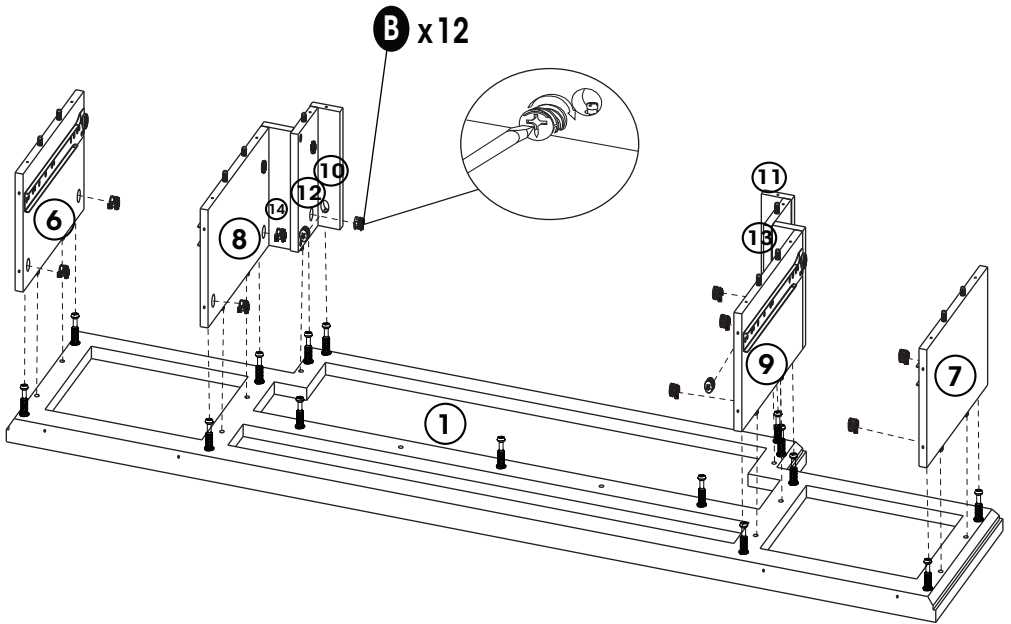

14

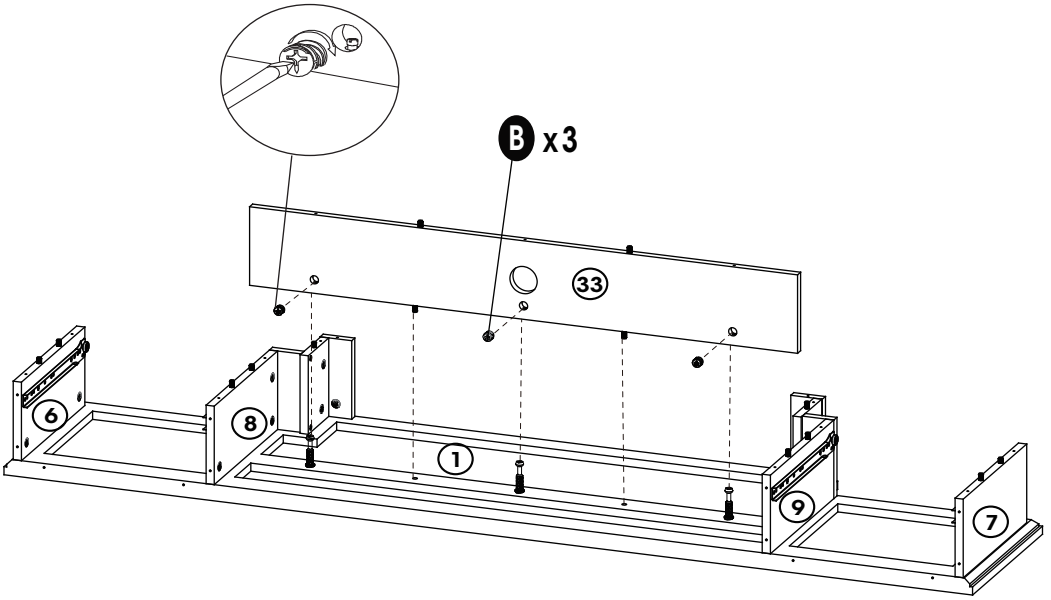

15

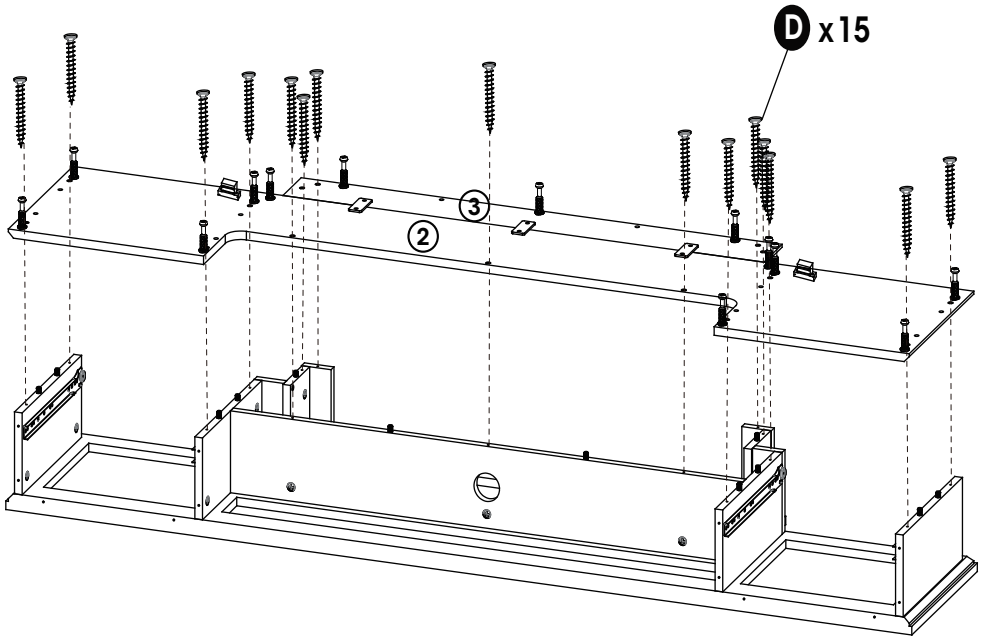

16



B x6



D x4

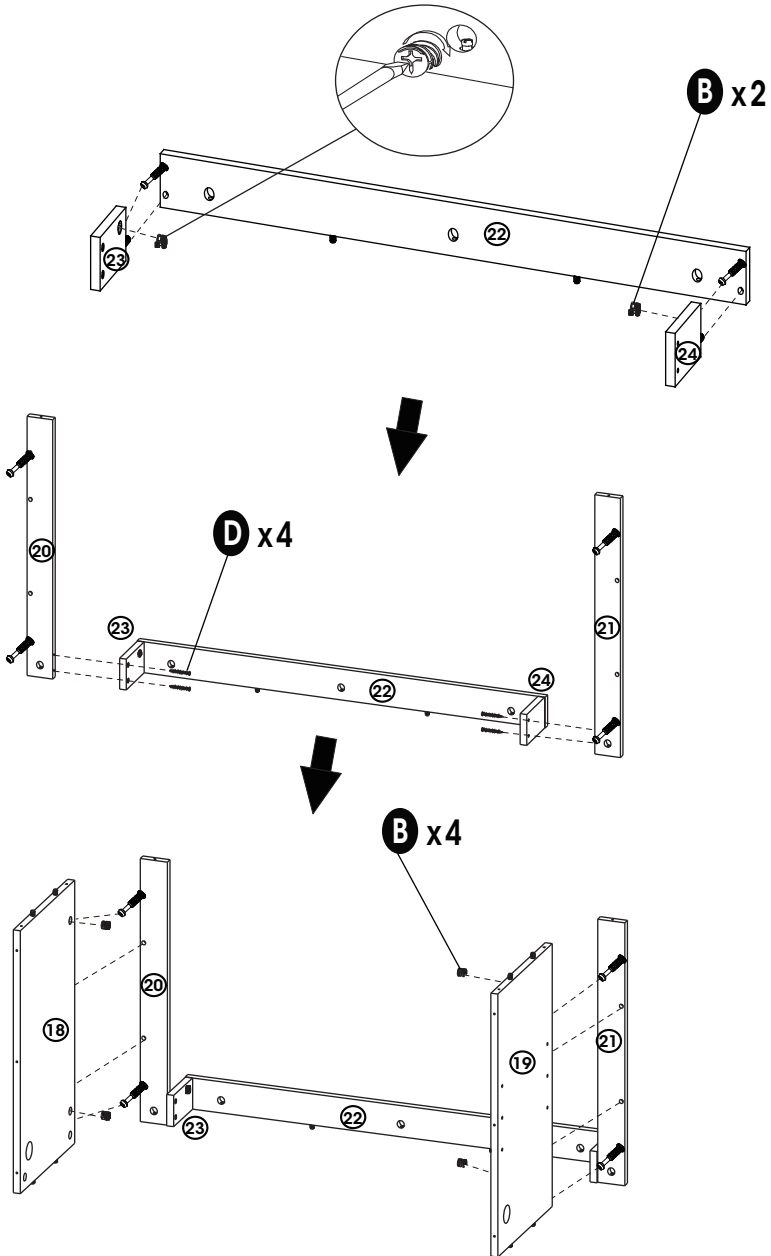

17



B x13

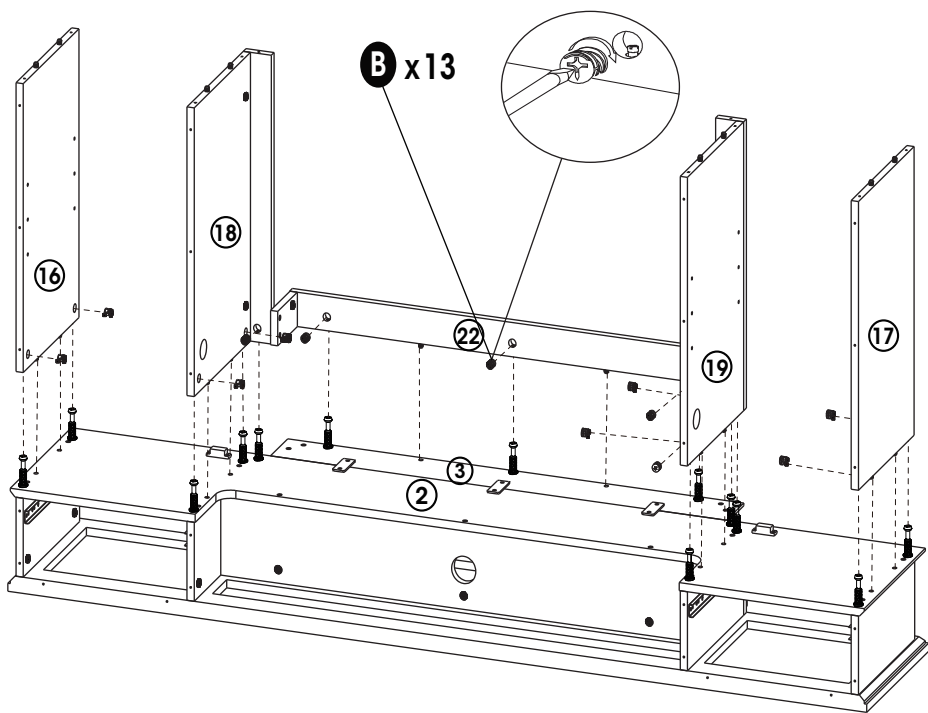

18

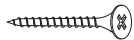

D x 8

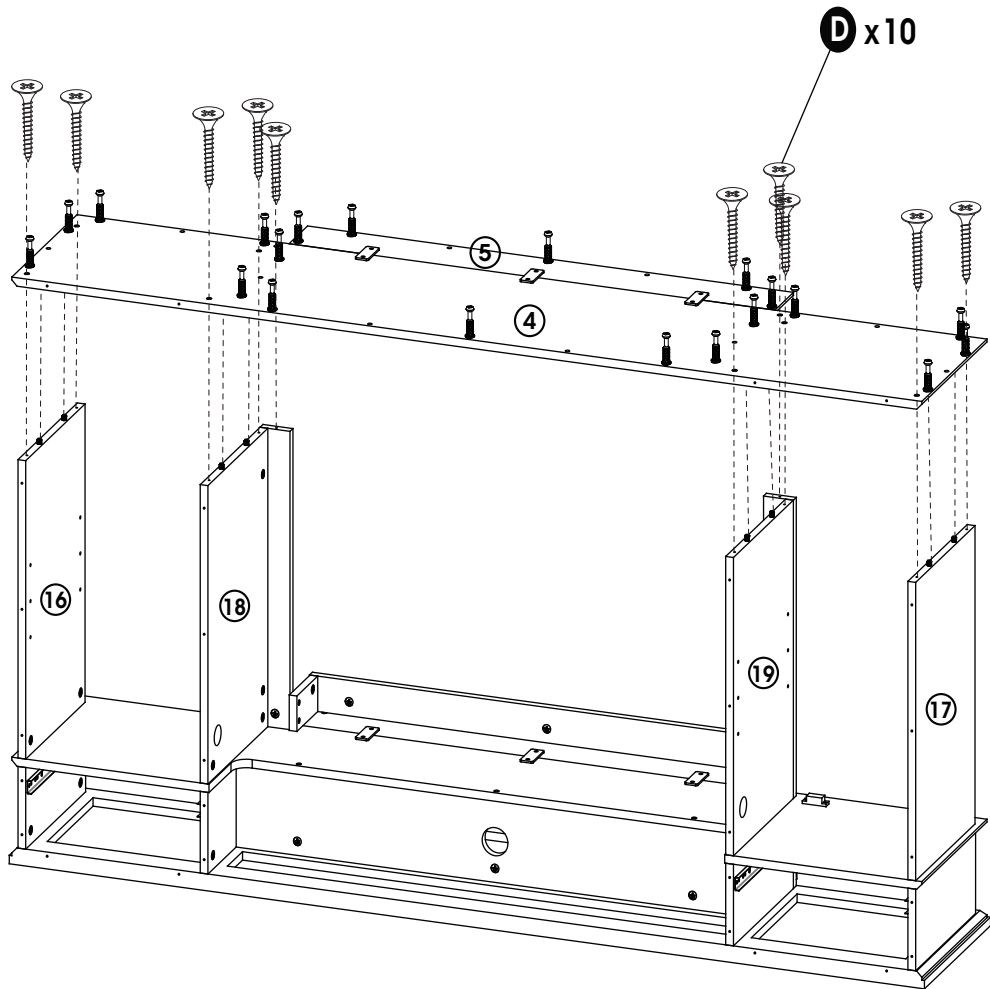

19

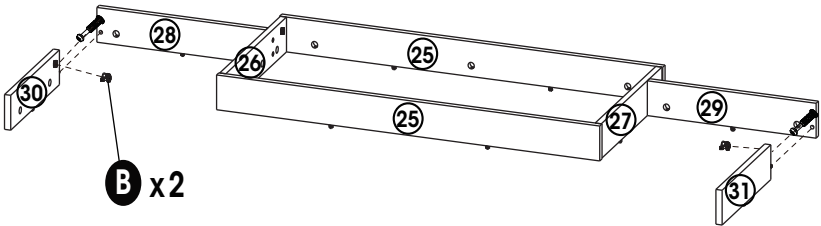
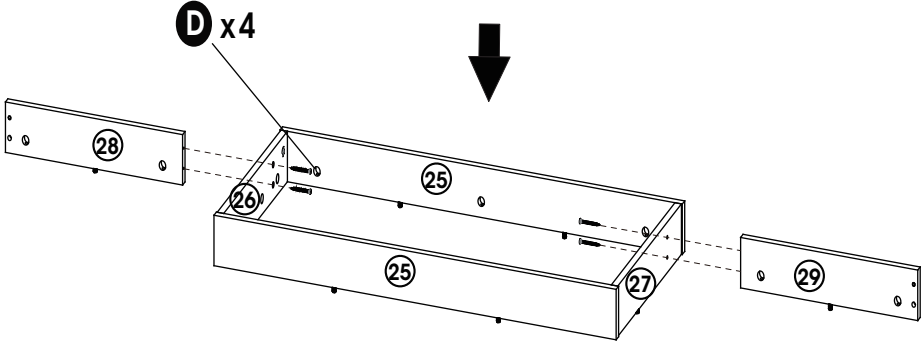
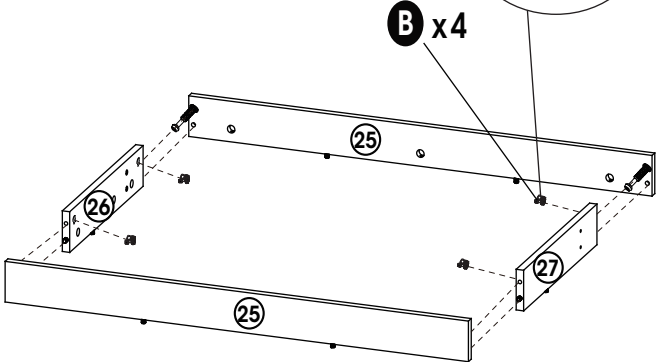
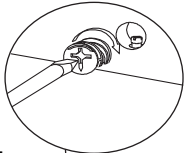

20



B x20

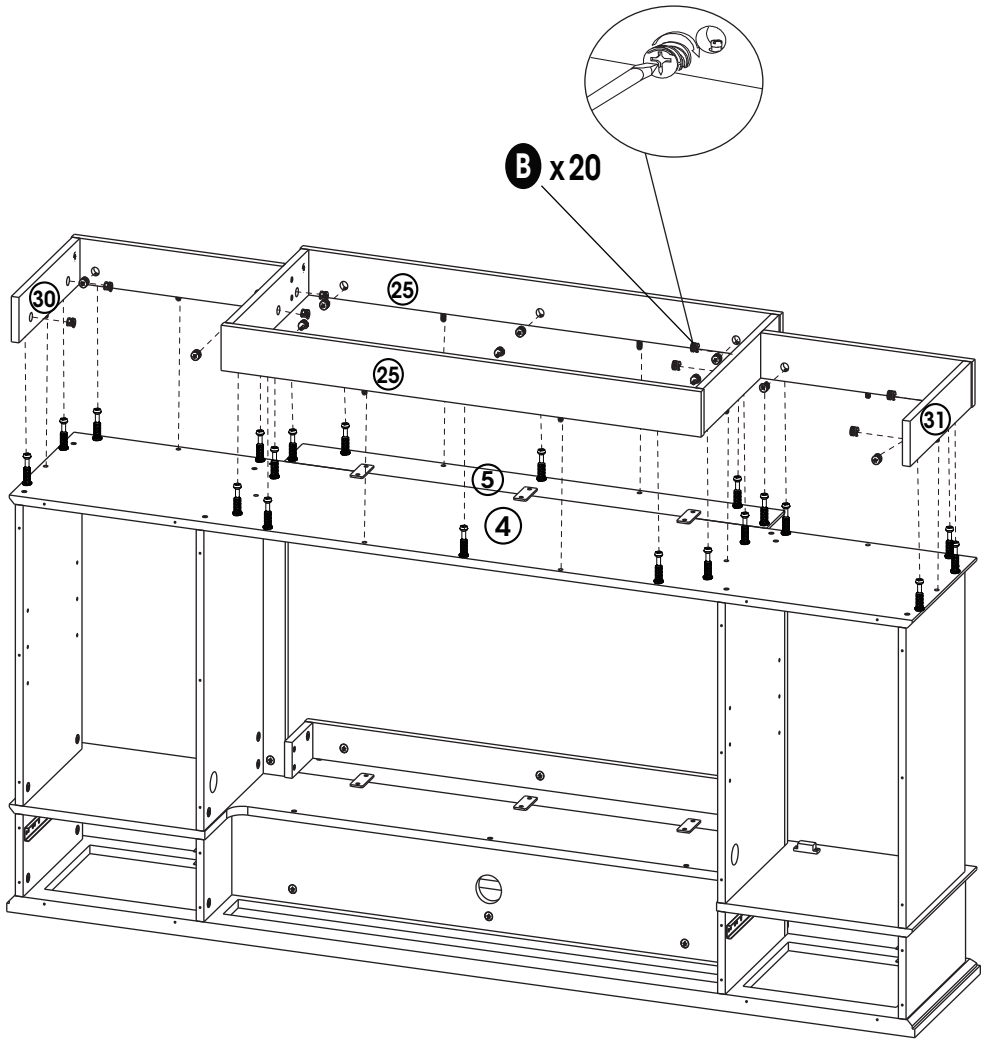

21



J x 28

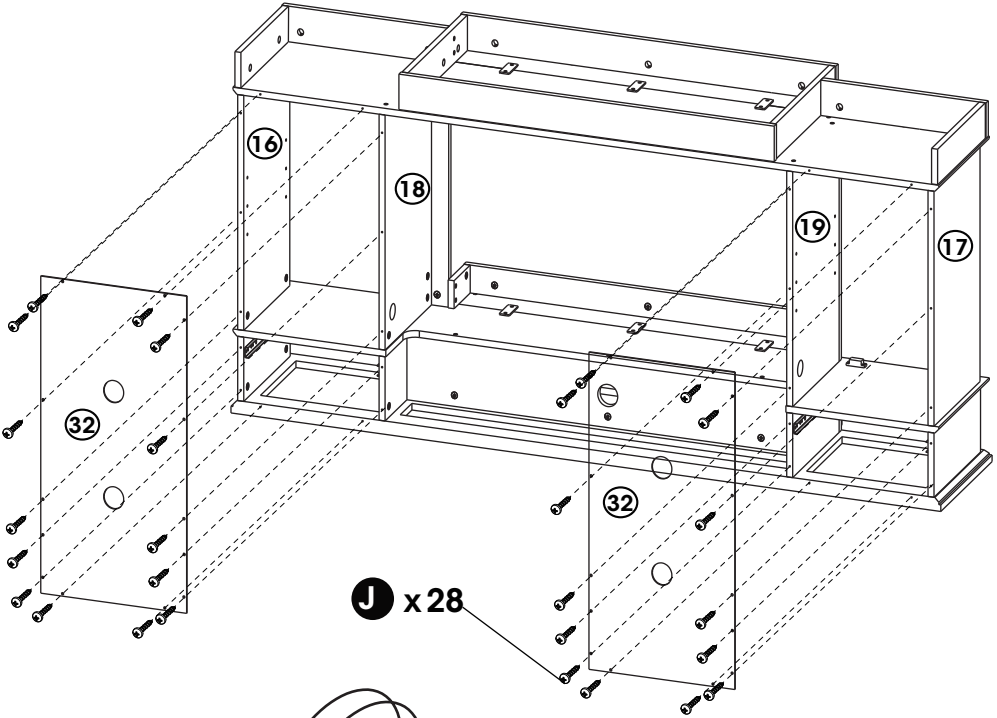

J x 28

Next, flip 180 °

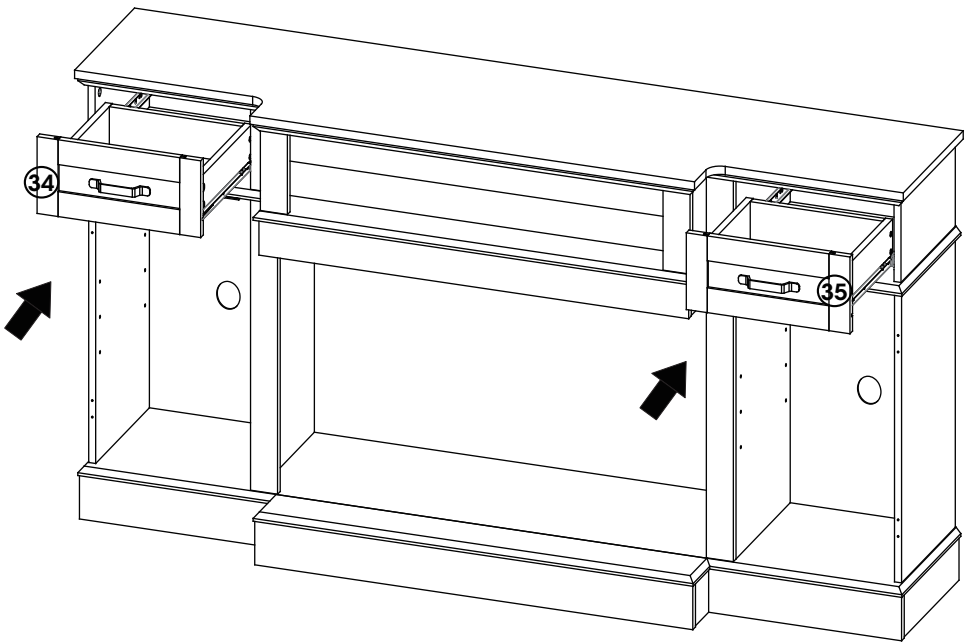

23

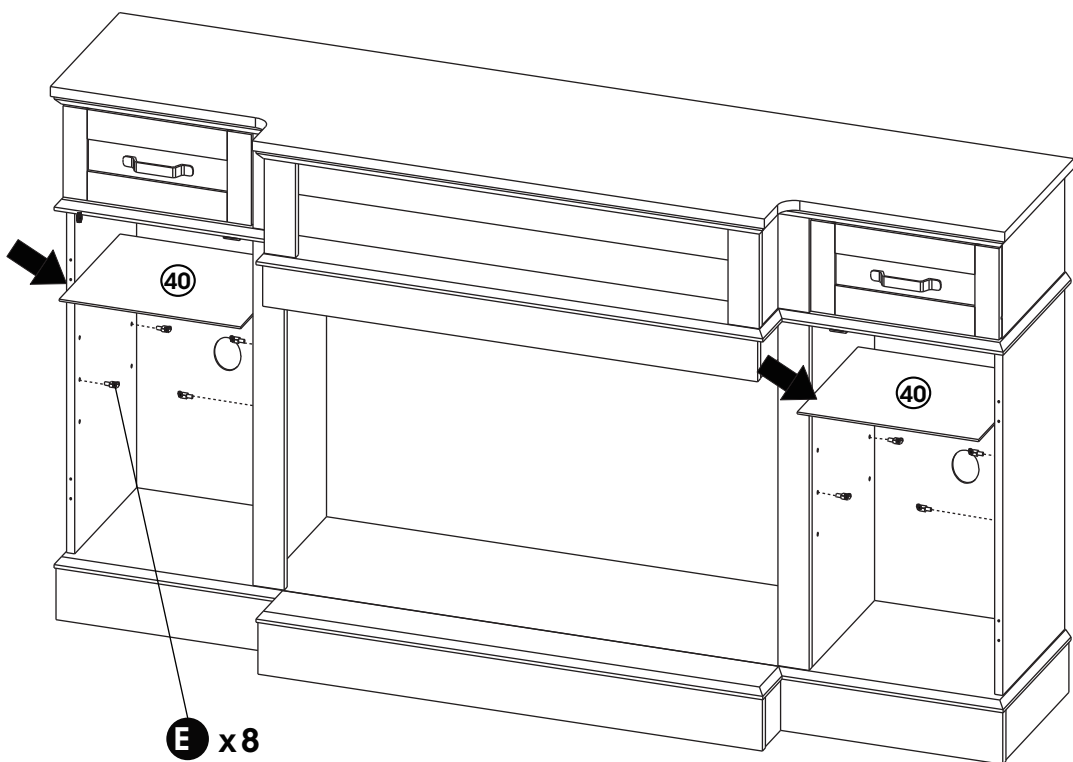

24

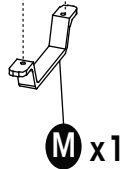
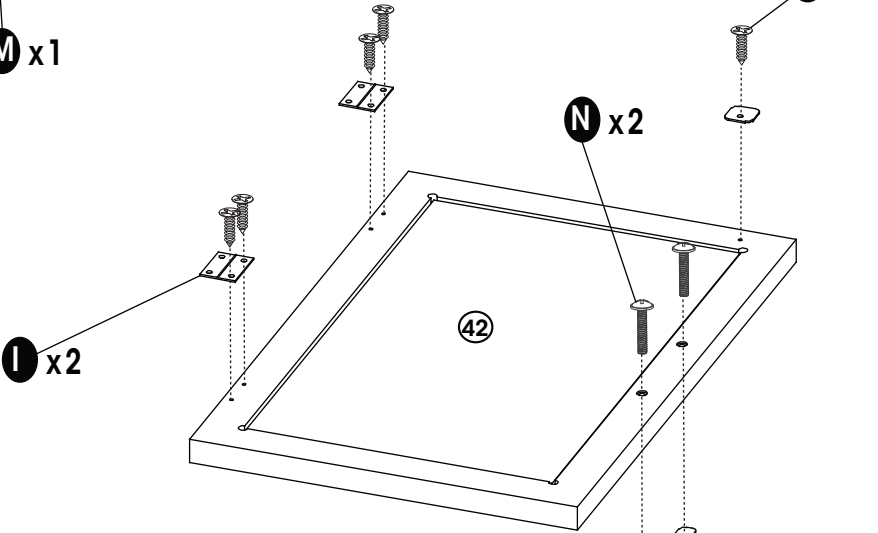
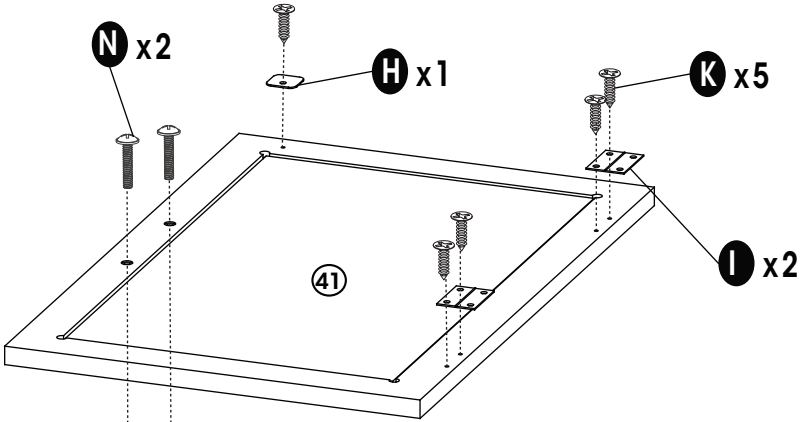
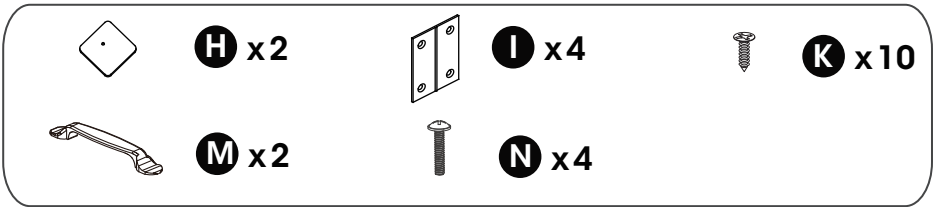

25



K x8

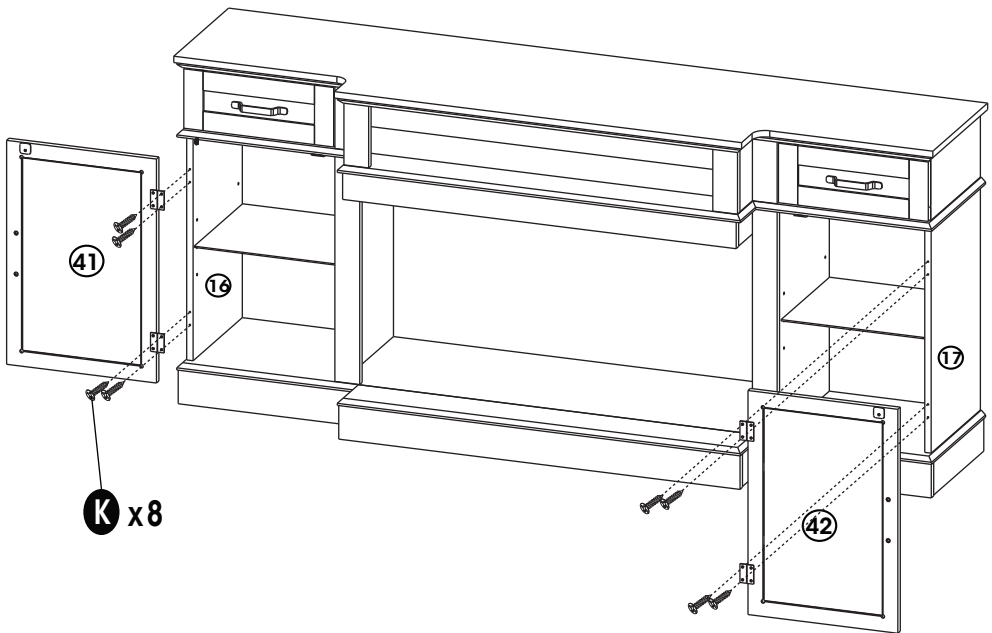

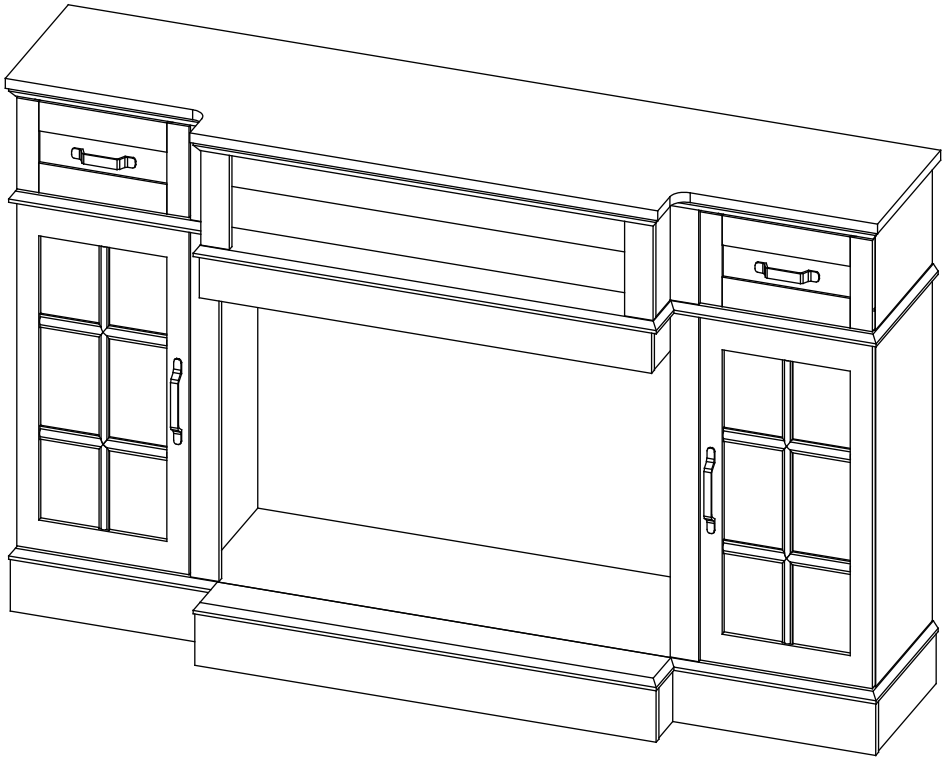

I HELP CENTER

Question about your product? We're here to help. Visit us at:



Chat Support



Product Inquiry



Orders FAQ



Product Assembly



Returns & Refunds

We Stand Behind the Quality of Their Furniture

If you have any issues with your item please let us know! We will always do our best to come up with a solution that you will be happy with.

Please get in touch with our customer service team before returning the product.

And pls do not throw the original box(es) if you have not finished assembling or confirmed no quality issues.

Length of return period:

Items can be returned within 30 days of purchase.

In the meanwhile, everything you purchased from us comes with a one-year warranty.

Who is responsible for the return shipping fee:

We will cover the return shipping fees if:

1. Your item has a manufacturing defect in its materials or workmanship. For example, torn wicker or misaligned screw holes. We will send you a prepaid shipping label after photos are sent.
2. Your item has been damaged in transit. For example, glass is broken or wicker is damaged. We will send you a prepaid shipping label after photos are sent.
3. You receive the wrong box(es) due to a warehouse error. We will send you a prepaid shipping label after photos are sent of the wrong SKU numbers on the outer box(es).
4. One or more boxes are lost in transit. We will send you a prepaid shipping label if you no longer want the item.

* However, we still hope to work with you for a better solution instead of a return. Please don't hesitate to contact our customer service team.

Customer will cover the return shipping fees if:

1. You don't like the product(s) after receiving the box(es).
2. You no longer need the product(s) but you have received the box(es).
3. You buy the product(s) by mistake but you have received the box(es).
4. Order/Shipment cancellation failed and you have received the box(es).

Return Request

In order to get a full refund as described in this return policy, all items must be: (1) In a brand new/unused condition, please provide photos before and after packaging. (2) When returning, all accessories and parts are firmly packed in all original packaging.

If your return does not meet the requirements, you may not get a full refund.

When will I be refunded?

The refund is released once the goods have been returned to our warehouse.

What if the product is damaged/defective outside of the valid return period?

We want you to be a happy customer. Please reach out to us by email and we will come up with a solution to make sure you are satisfied.

Reach us at

 service@kmcglobe-us.com

 (+1) 559-354-1889