

ASSEMBLY INSTRUCTIONS

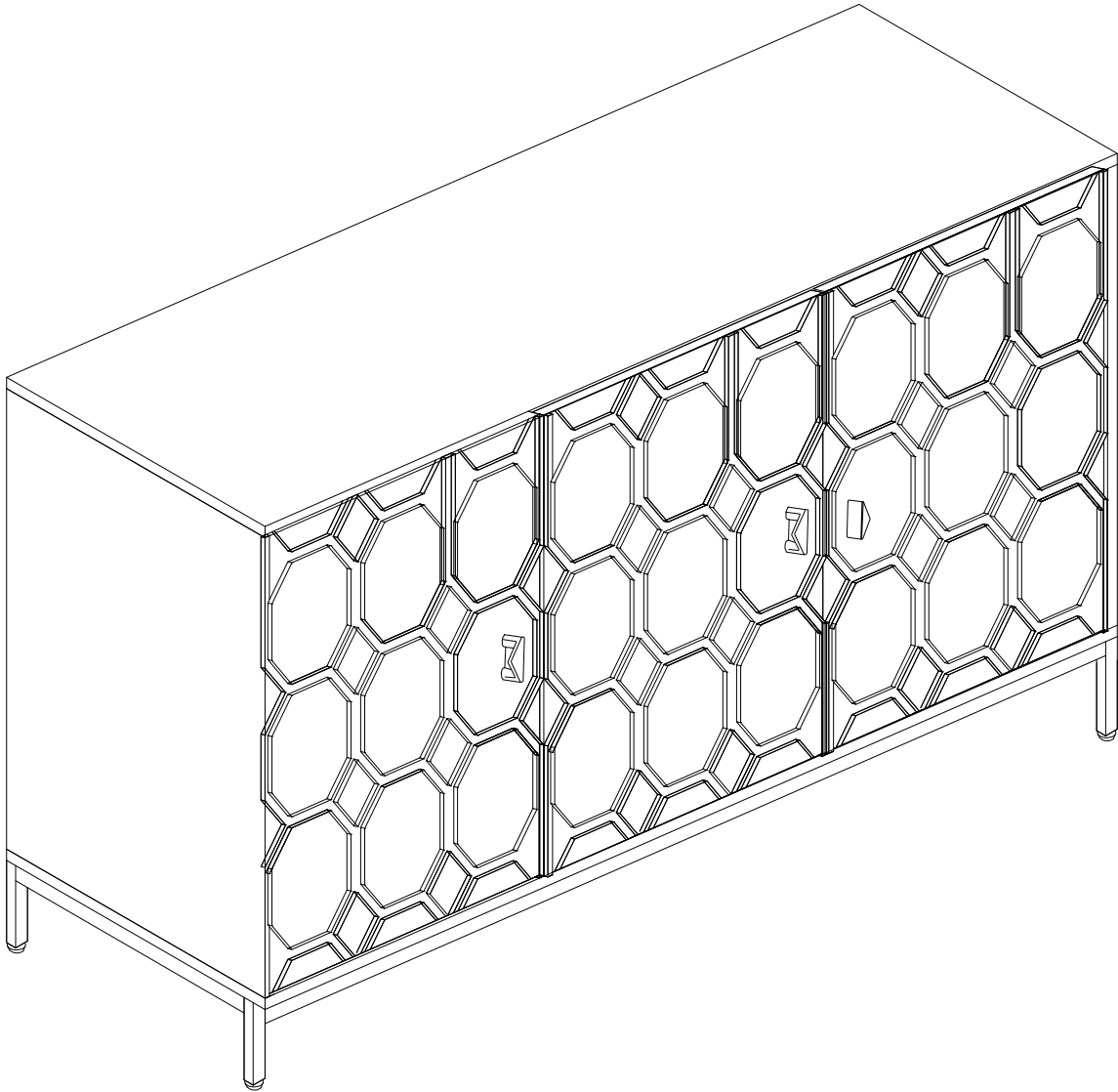

WARNING:



TIPPING HAZARD. This cabinet can tip over if not secured, causing serious injury or death. Always attach to the wall using the safety wall strap (Part M) provided. Never allow children to climb on doors, shelves, or use the product as a step.

U.S. Customer Service: (951) 213-4742 (Mon-Fri, 9AM-5PM PST)
Email: contactus24service@gmail.com

MADE IN MALAYSIA

ASSEMBLY INSTRUCTIONS

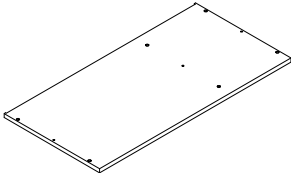
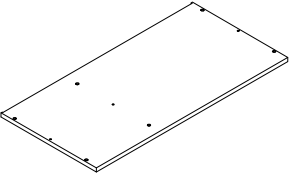
Part list:

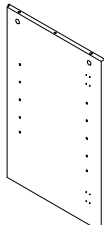
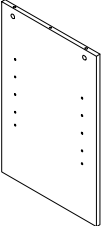
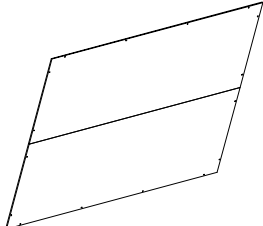



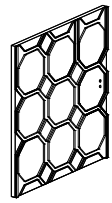
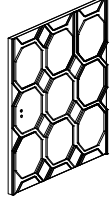
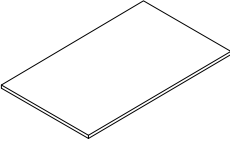
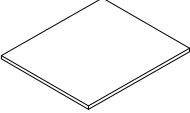
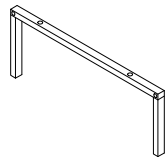
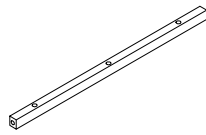

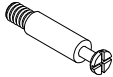

ITEM	DESCRIPTION	PART	QTY
1	Top panel		1
2	Bottom panel		1
3	Left side panel		1
4	Right side panel		1
5	Middle side plate		1
6	Back panel		1

Part list:









ITEM	DESCRIPTION	PART	QTY
7	Left door		2
8	Right door		1
9	Adjustable movable plate (long)		1
10	Adjustable movable plate (short)		1
11	Leg		2
12	Leg		2

ASSEMBLY INSTRUCTIONS

Hardware List:

ITEM	DESCRIPTION	PART	QTY
A	Camlock bolt		6
B	Camlock		6
C	Wooden dowel	 Φ0.31*1.18"	6
D	Bolt	 Φ0.23*1.18"	10
E	Allen wrench		1
F	Bolt	 Φ0.23*1.57"	4
G	Handle		3
H	Machine screw	 Φ0.15*0.7"	6
I	Door hing (big bend)		6

Hardware List:

ITEM	DESCRIPTION	PART	QTY
J	Round head screw	 Φ0.15*0.55"	36
K	Back screw	 Φ0.11*0.55"	20
L	Shelf support		8
M	Safety wall strap		2
N	Plastic anchor		2
O	Mounting screw	 Φ0.15*1.57"	2
P	Washer		2
Q	Mounting screw	 Φ0.15*1.37"	6

ASSEMBLY INSTRUCTIONS

- * Required screwdriver & mallet, not included.
- * Before discarding packing materials, please check to make sure that all parts and hardware is present.
- * Two people needed for assembly.
- * Please follow the instructions closely; Do not over-tighten screws or bolts unless specified.
- * After a few days from initial assembly, the product may adjust to the environment. Please retighten the hardware.

Guideline For Assembling of Cam Lock (A & B)

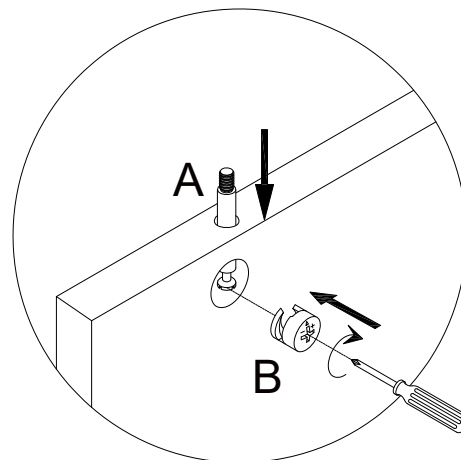
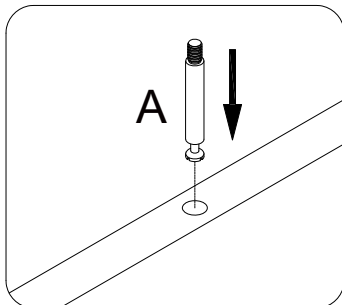





Screw camlock bolt (A) to wood part.

Do not assemble camlock (B) unless instructed.

To assemble camlock (B), ensure long side of the + is facing the bolt (A) before inserting into hole.

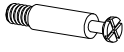
ASSEMBLY INSTRUCTIONS

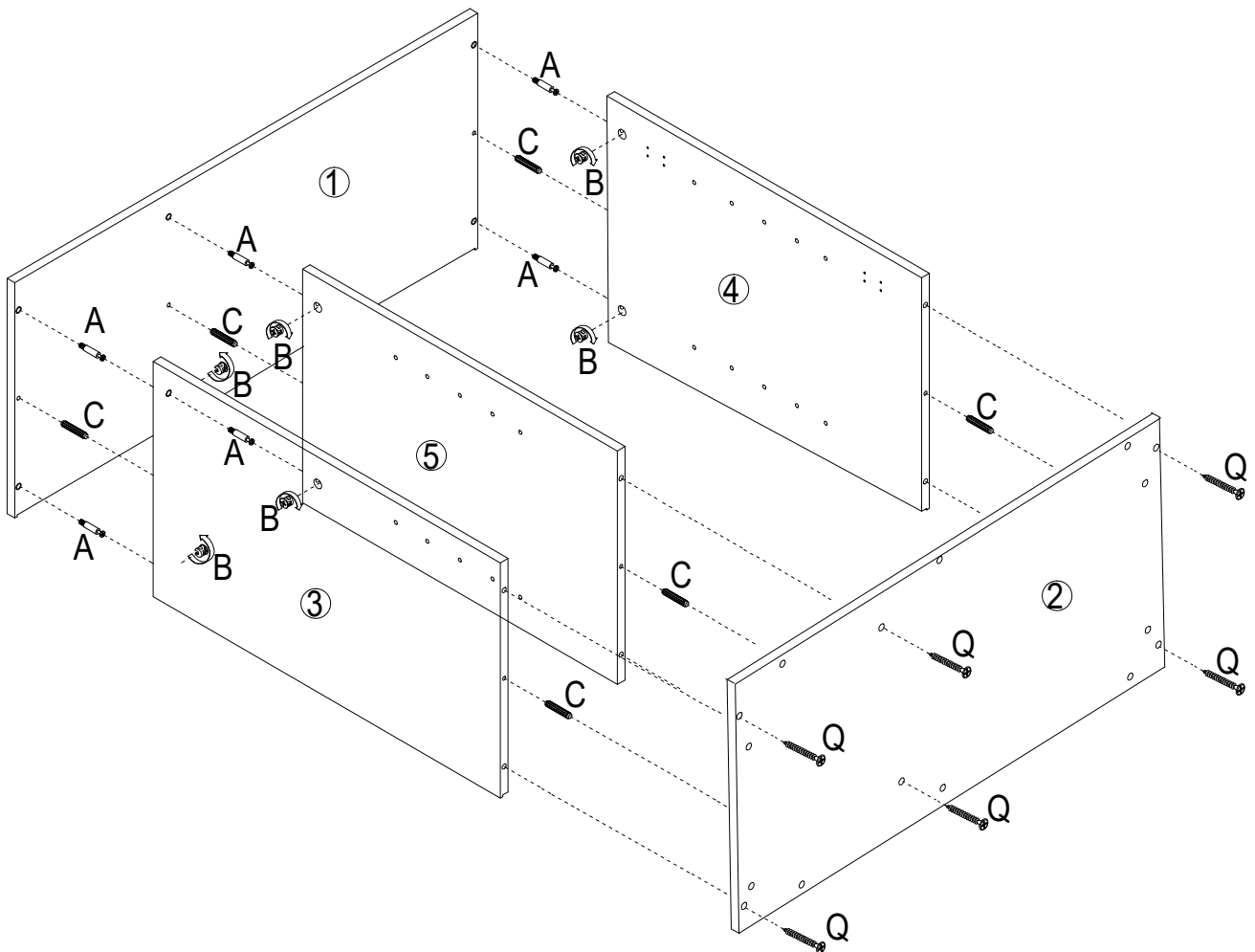

STEP 1

A:		6PCS
B:		6PCS
C:		6PCS
Q:		6PCS



ASSEMBLY INSTRUCTIONS

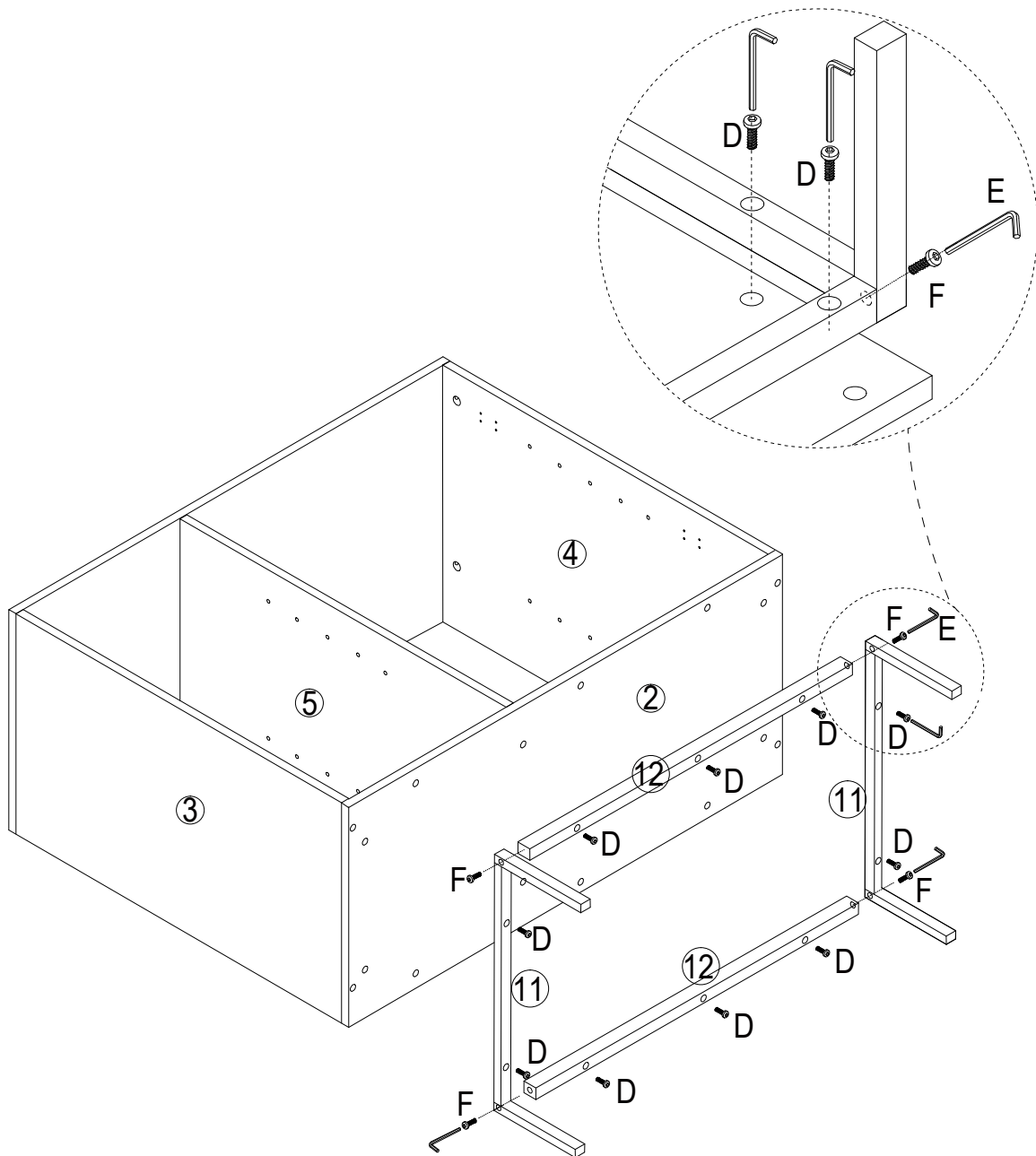

STEP 2

D:		10PCS
E:		1PC
F:		4PCS





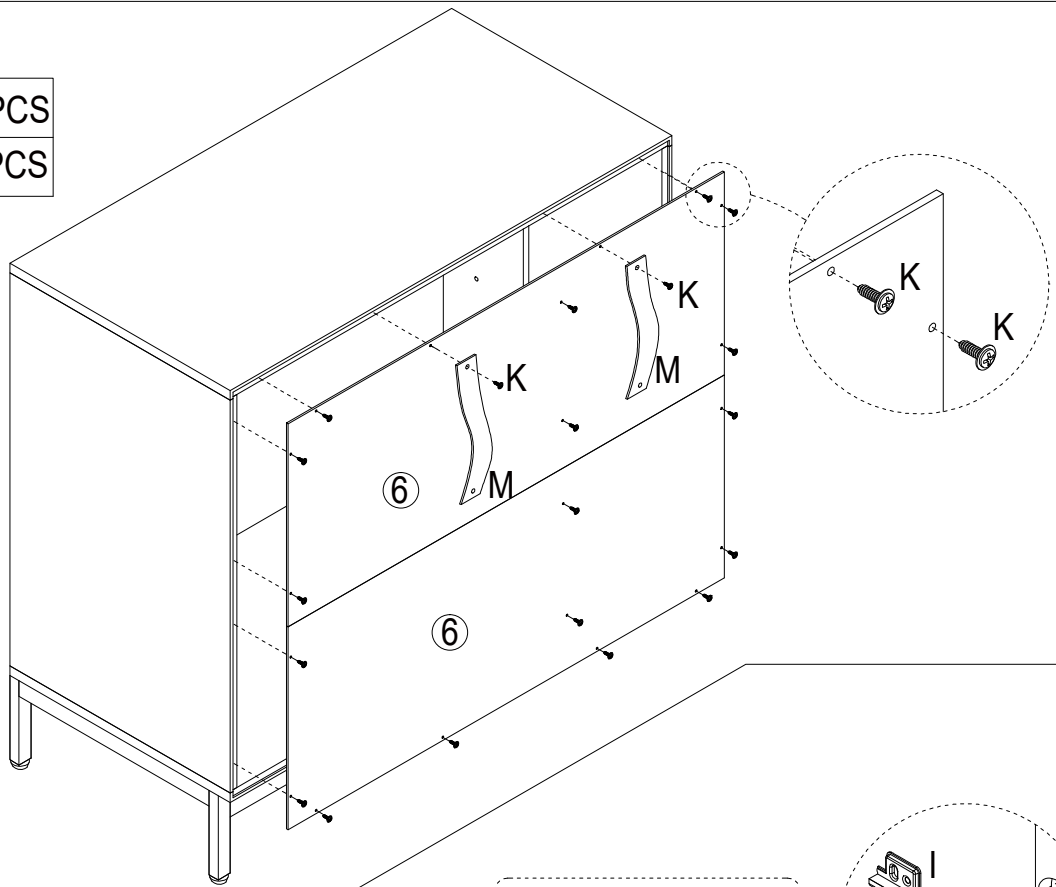

ASSEMBLY INSTRUCTIONS

STEP 3

K:		20PCS
M:		2PCS



STEP 4

G:		3PCS
H:		6PCS
I:		6PCS
J:		12PCS

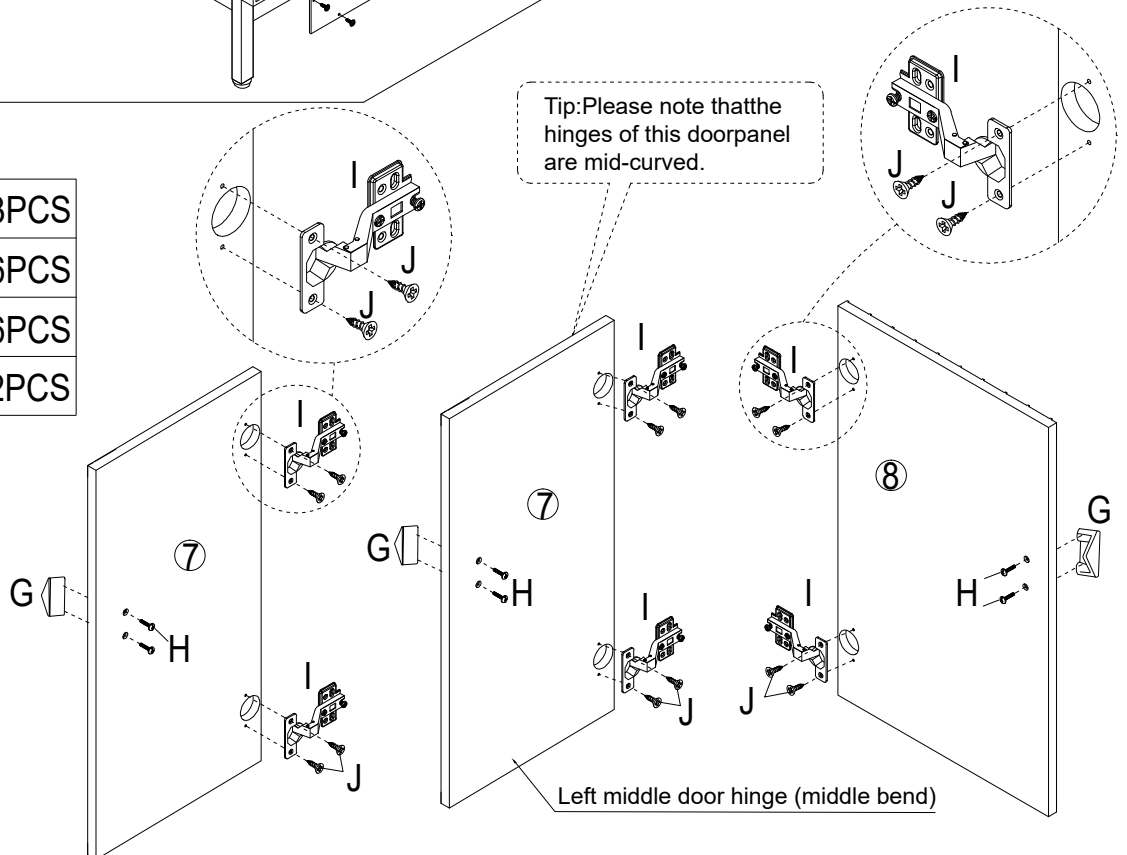

Left middle door hinge (middle bend)

ASSEMBLY INSTRUCTIONS

STEP 5

J:  24PCS

To adjust door width: Loosen screws on Part I (Door hinge), shift door left/right, then retighten with Part J (Round head screw).

To adjust door height: Adjust the vertical position of the hinges (I) and secure with Part J to ensure the door is level with the cabinet frame.

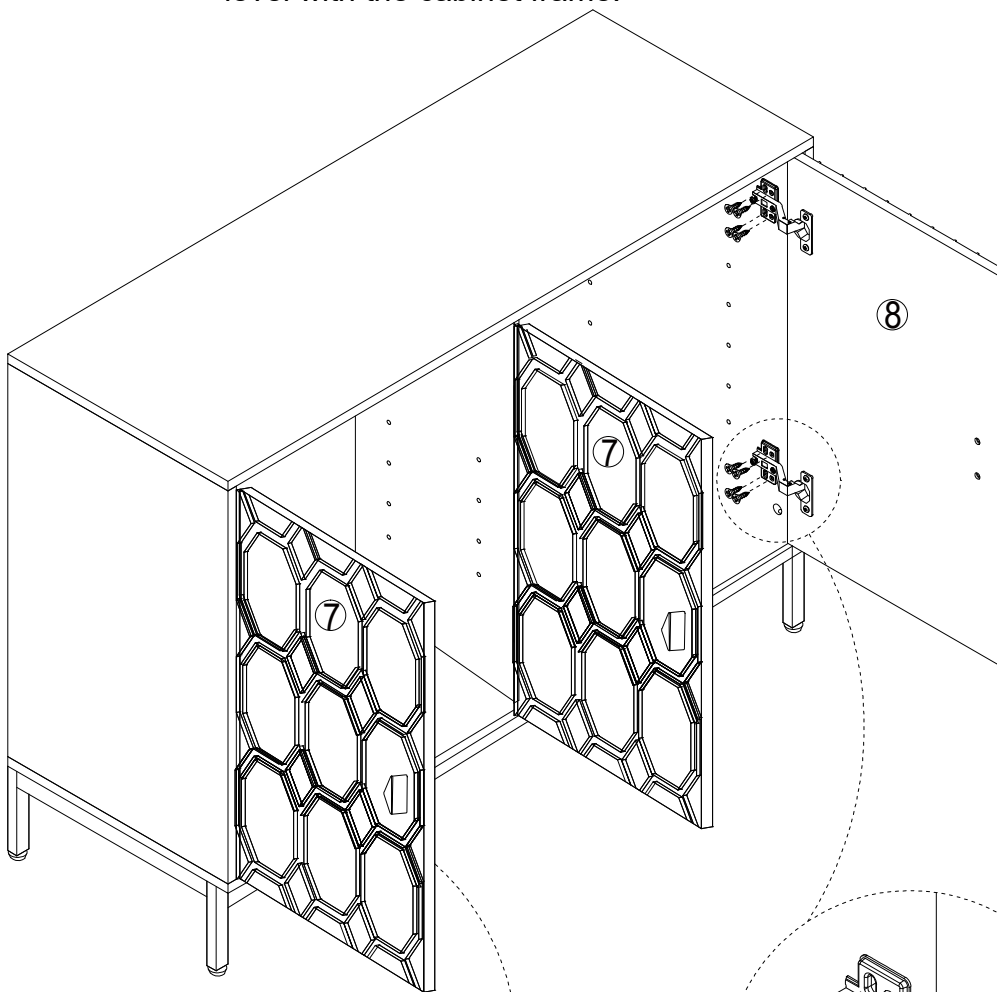

DOOR FITTING

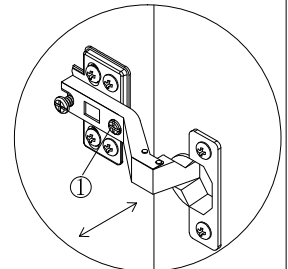

To adjust in width

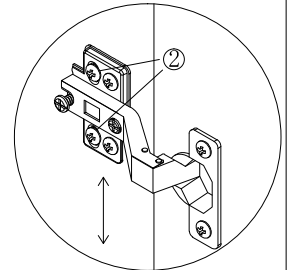

To adjust in height

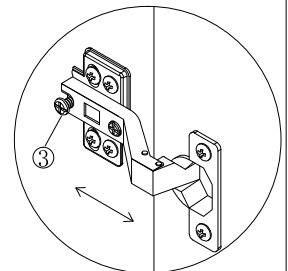

To adjust in depth

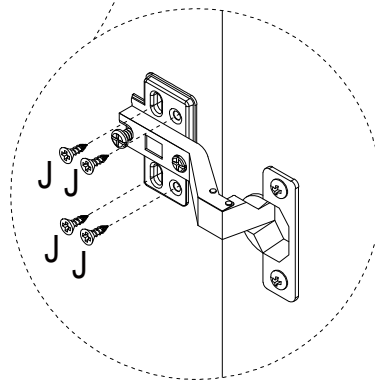
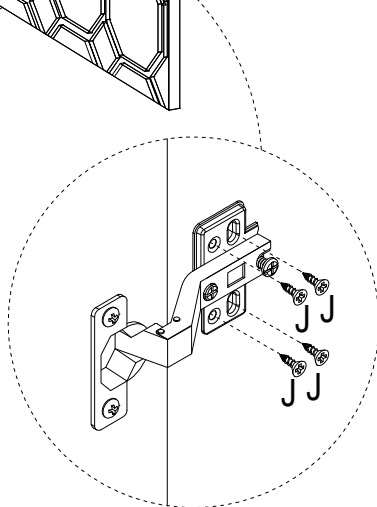

ASSEMBLY INSTRUCTIONS

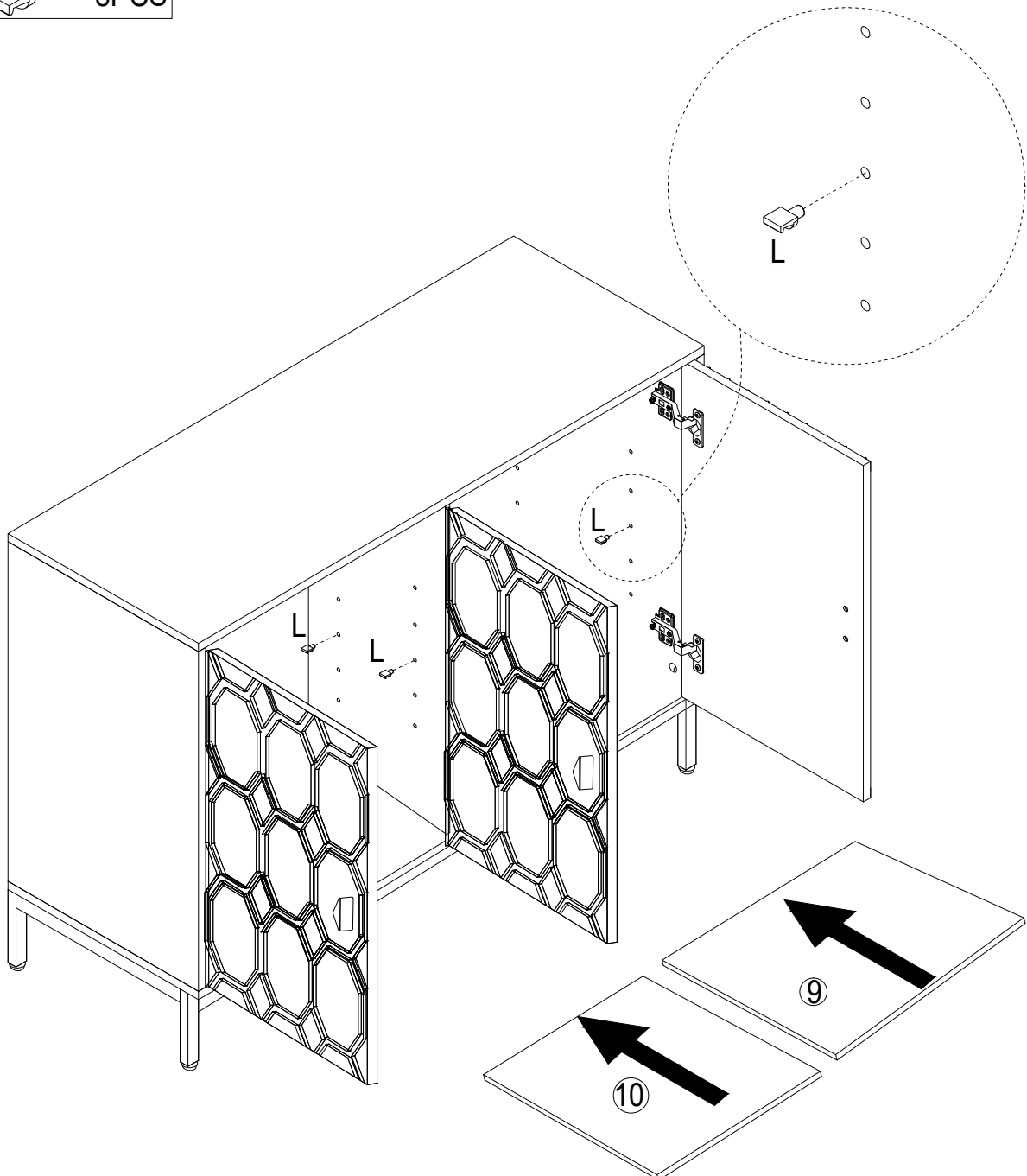

STEP 6

L:  8PCS

Insert 8 pieces of Part L (Shelf support peg) into pre-drilled holes at desired heights, then place Part 9 (Long adjustable shelf) and Part 10 (Short adjustable shelf) on top.

ASSEMBLY INSTRUCTIONS

STEP 7 Mark the wall at the height matching the pre-drilled holes on Part 6 (Back panel).

N:		2PCS
O:		2PCS
P:		2PCS

Drill a 1/8" hole, insert Plastic anchor (Part N) into the hole.

Place Washer (Part P) over Mounting screw (Part O), then drive the screw through Safety wall strap (Part M) and into the anchor. Tighten until the strap is firmly attached to the wall. Repeat for the second strap."

