

## Assembly Instructions

### Stage 1 - Fitting the Unit

**NOTE:** It would be useful to ask someone to help you at this stage.

1. Insert the Back Rest onto the Seat Cushion.

**NOTE:** Carefully align the two side Metal Locks. Ensure they align correctly.

2. Engage the Metal Locks and push fit. You should hear them lock into position.
3. Fit the Velcro cover on the Back Rest onto the Velcro on the back of Seat Cushion.

See fig. 1

**CAUTION:**  
DO NOT ALLOW CHILDREN TO PLAY ON THIS MECHANIZED FURNITURE OR OPERATE THE MECHANISM. LARGEST FOLDS DOWN ON CLOSING SO THAT A CHILD COULD NOT POSSIBLY BE INJURED. ALWAYS LEAVE IN AN UPRIGHT AND CLOSED POSITION. KEEP HANDS AND FEET CLEAR OF MECHANISM. ONLY OCCUPANT SHOULD OPERATE IT.

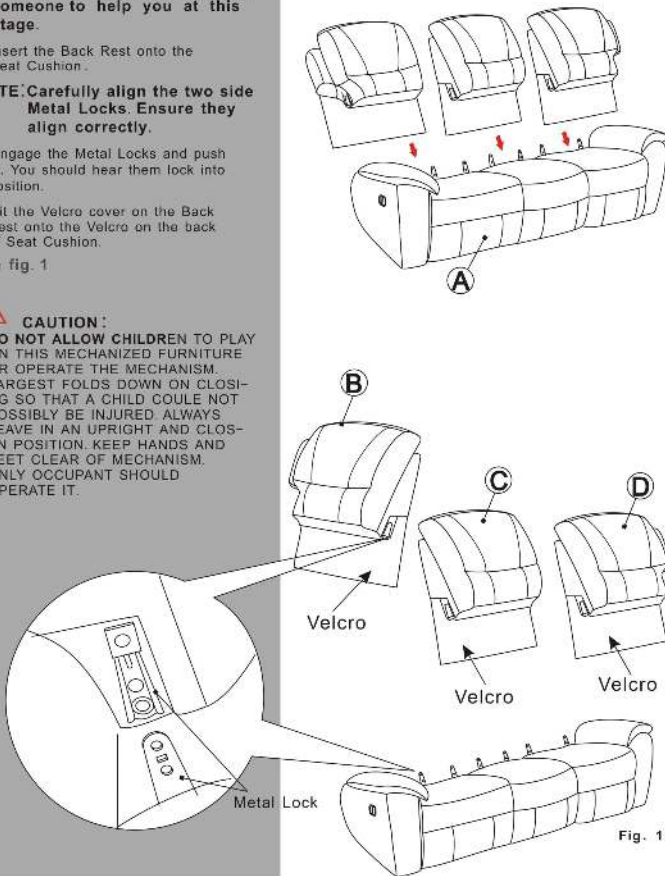

## Assembly Instructions

### Stage 2 - Fitting the Unit

#### Back and Foot Rest Adjustment

This Chair features a reclining back rest and raised foot rest. You need to be sitting in the chair to activate the features.

1. Pull the "Adjustment Lever" and gently lean back and the chair will recline and the foot rest will automatically lift up.

See fig. 2

2. Pull the "Adjustment Lever" again and lean forward, the back rest will move forward and the foot rest will lower.

See fig. 2

3. Adjust the recliner to your own requirements.

**NOTE:** It would be useful ask someone to help you at this stage.

4. Finally carefully place the unit in the desired location.

See fig. 3

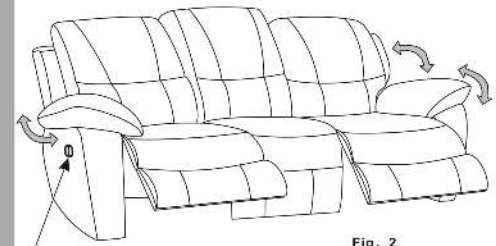

Adjustment  
Level

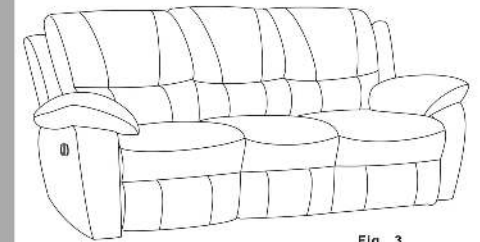

## Care and Maintenance

### Safety

To avoid any risk of suffocation to animals or children dispose of the plastic bags immediately.

### Cleaning

As with all surfaces clean with a damp cloth and mild detergent, do not use bleach or abrasive products.

### Fitting

From time to time please ensure there are no loose screws on the product.

## Simple Assembly Instructions-Please keep for future reference

## Components

### IMPORTANT

1. Read this instruction carefully and familiarize yourself with procedure before assembling the unit.
2. Check that you have all the component parts and familiarize yourself with each part before proceeding.
3. Take all the fitting out of the plastic bag and separate them into group.
4. Ensure you have enough space layout all the parts before assembly.
5. To Avoid scratching it is recommended that you assemble the unit on the soft level of surface

### FCC MARKING

This device complies with Part 15 of the FCC rules.

Operation is subject to the following two conditions: (1) This device may not cause harmful interference, and (2) this device must accept any interference received, including interference that may cause undesired operation.

**CAUTION:** Changes or modifications not expressly approved by the party responsible for compliance could void the user's authority to operate the equipment.

**NOTE:** This equipment has been tested and found to comply with the limits for Class B digital device, pursuant to Part 15 of the FCC rules. These limits are designed to provide reasonable protection against harmful interference in a residential installation, this equipment generates, uses and can radiate radio frequency energy and, if not installed and used in accordance with the instructions, may cause harmful interference to radio or television reception, which can be determined by turning the equipment off and on, the user is encouraged to try to correct the interference by one or more of the following measures:

\*Reorient or relocate the receiving antenna.

\*Increase the separation between the equipment and the receiver.

\*Connect the equipment into an outlet on the circuit different from that to which the receiver is connected.

Consult the dealer of an experienced Radio/TV technician for help.

**NOTE:** For a Class A digital device, statements of 15.105(a) must be included when appropriate for the device in question.

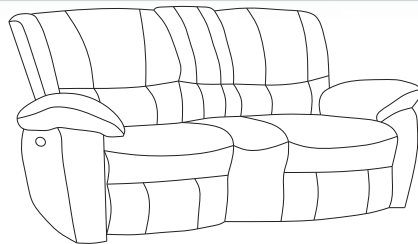

Fig.3

## Do not use power tools

- A** Seat cushion    **B** Left back cushion    **C** Console cushion  
**D** Right back cushion

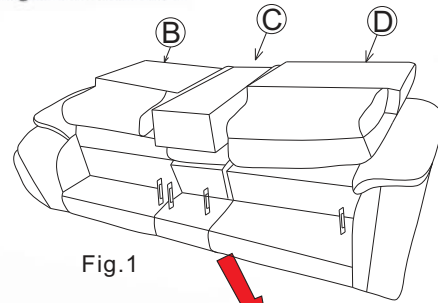

Fig.1

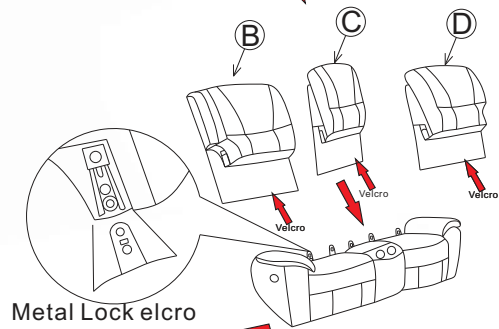

Fig.2