

# ASSEMBLY INSTRUCTIONS

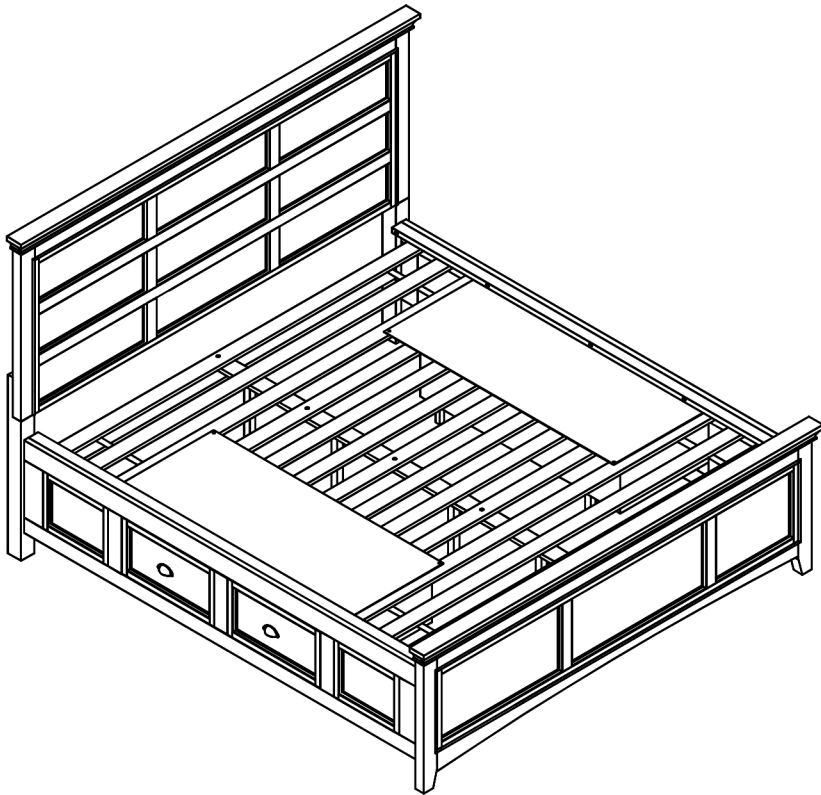

## TOOLS REQUIRED



Allen Wrench  
(Included)



Wrench  
(Included)



Phillips Screwdriver  
(Not Included)

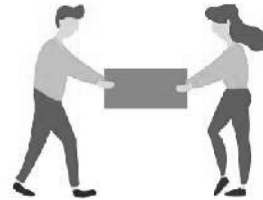

2 - Persons  
Recommended

## ASSEMBLY RATING



EASY ————— DIFFICULT

The Assembly Rating is a 5-point system showing the level of effort needed to assemble a specific product.



## **CHECK BEFORE STARTING**

### **Are you missing anything?**

Double-check all parts, hardware and accessories listed are all accounted for.

### **Check out our Quick Tips!**

We recommend reviewing the pre-assembly handouts. Even experts need a refresher now and then!

### **Should we send any replacements?**

Are there any irregularities or flaws in the parts? We can send replacements!

### **Prep Time!**

Please review the assembly instructions and all diagrams prior to assembling.

# PRE ASSEMBLY INTRODUCTION

We understand building ready-to-assemble furniture can be a challenging experience for some. To help avoid confusion, we have provided some helpful tips that may speed up the process.

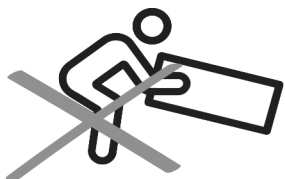

## Teamwork

ALWAYS have at least two people to help with transporting and assembling the product to avoid potential injury and/or damage.

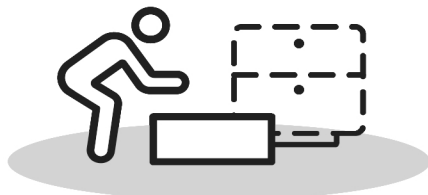

## Suitable Location

Assembling near the area of the intended location is highly recommended.



## Sufficient Space

Make sure you have enough space to move around during the assembly.



## Avoid Scratches

Use cardboard, blankets or a carpeted area while assembling furniture to prevent to prevent scratches and damages.

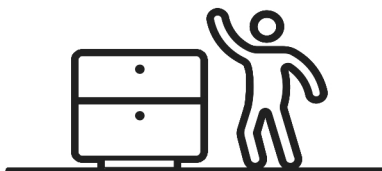
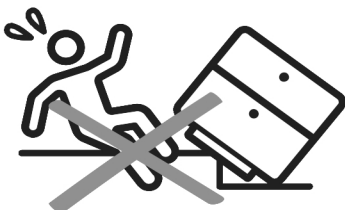

## Flat Surface

Make sure the furniture rests on a flat and level surface with each leg evenly touching the floor.

# ASSEMBLY AND CARE ADVICE



**FAILURE TO FOLLOW THE GUIDELINES BELOW MAY RESULT IN INJURY AND/OR PROPERTY DAMAGE.**



Position each part correctly and insert screws or bolts into their respective holes.

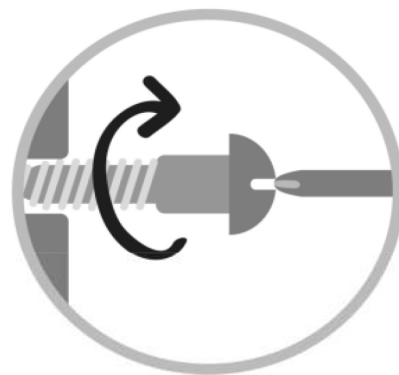

Turn clockwise to tighten and only tighten when step is completed or when instructed to do so.



Use the appropriate hand tools or power tools for assembly. Select steps, such as tightening screws and/or bolts, may require hand tools to avoid causing damage during assembly.



Save the instructions and store any supplied tools for later maintenance.



After two weeks, check and tighten any loose hardware and repeat again every six months thereafter.

**IT IS THE USER'S RESPONSIBILITY TO MAINTAIN THE FURNITURE. THE HARDWARE MAY LOOSEN OVER TIME AND MAY CAUSE THE FURNITURE TO BE WOBBLY AND UNABLE TO SUPPORT ITS INTENDED WEIGHT CAPACITY. THIS MAY LEAD TO COLLAPSE AND MAY CAUSE SERIOUS INJURY.**

# BED

- Please keep instructions for future reference.
- Check the quantity and irregularity of parts and hardware before you start.

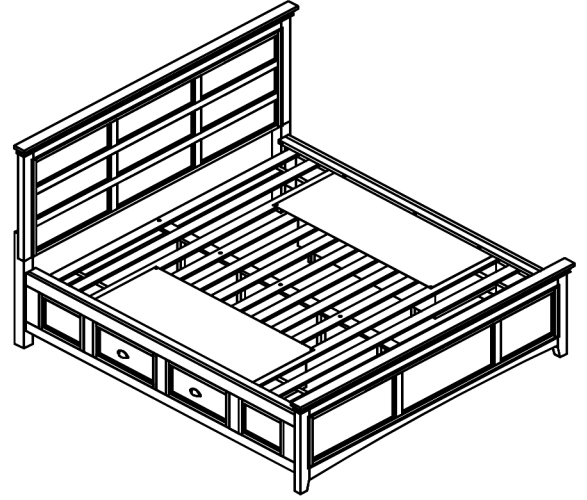

## PARTS

#1 1pc

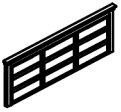

Headboard Panel

#2 2pcs



HB Leg (L&R)

#3 1pc

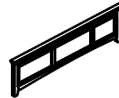

Footboard

#4 2pcs



Side Rail

#5 1pc



HB Support

#6 2pcs

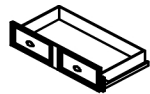

Drawers

#7 1set

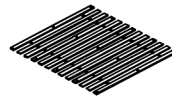

Bed Slat (13pcs)

#8 1pc



Slat Center Support

#9 4pcs

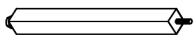

Support Leg (Long)

#10 4pcs

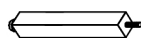

Support Leg (Short)

#11 2pcs



Conceal Panel

#12 2pcs



Top Side Rail

## HARDWARE

#A 10pcs



Bolt  
Ø5/16" x 2"

#B 10pcs



Lock Washer  
Ø5/16"

#C 10pcs



Flat Washer  
Ø5/16"

#D 1pc



Allen Wrench  
4mm

#E 15pcs

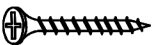

Screw  
#4 x 30mm

#F 8pcs



Threaded Pins  
Ø5/16" x 3-1/2"

#G 8pcs



Hex Nut  
Ø5/16"

#H 8pcs



Half Moon washer  
Ø5/16"

#I 1pc



Wrench  
12mm

#J 8pcs

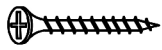

Screw  
#4 x 12mm

#K 12pcs



Bolt  
Ø1/4" x 1-1/2"

#L 22pcs



Lock Washer  
Ø1/4"

#M 22pcs



Flat Washer  
Ø1/4"

#N 1pc



Allen Wrench  
4mm

#O 10pcs







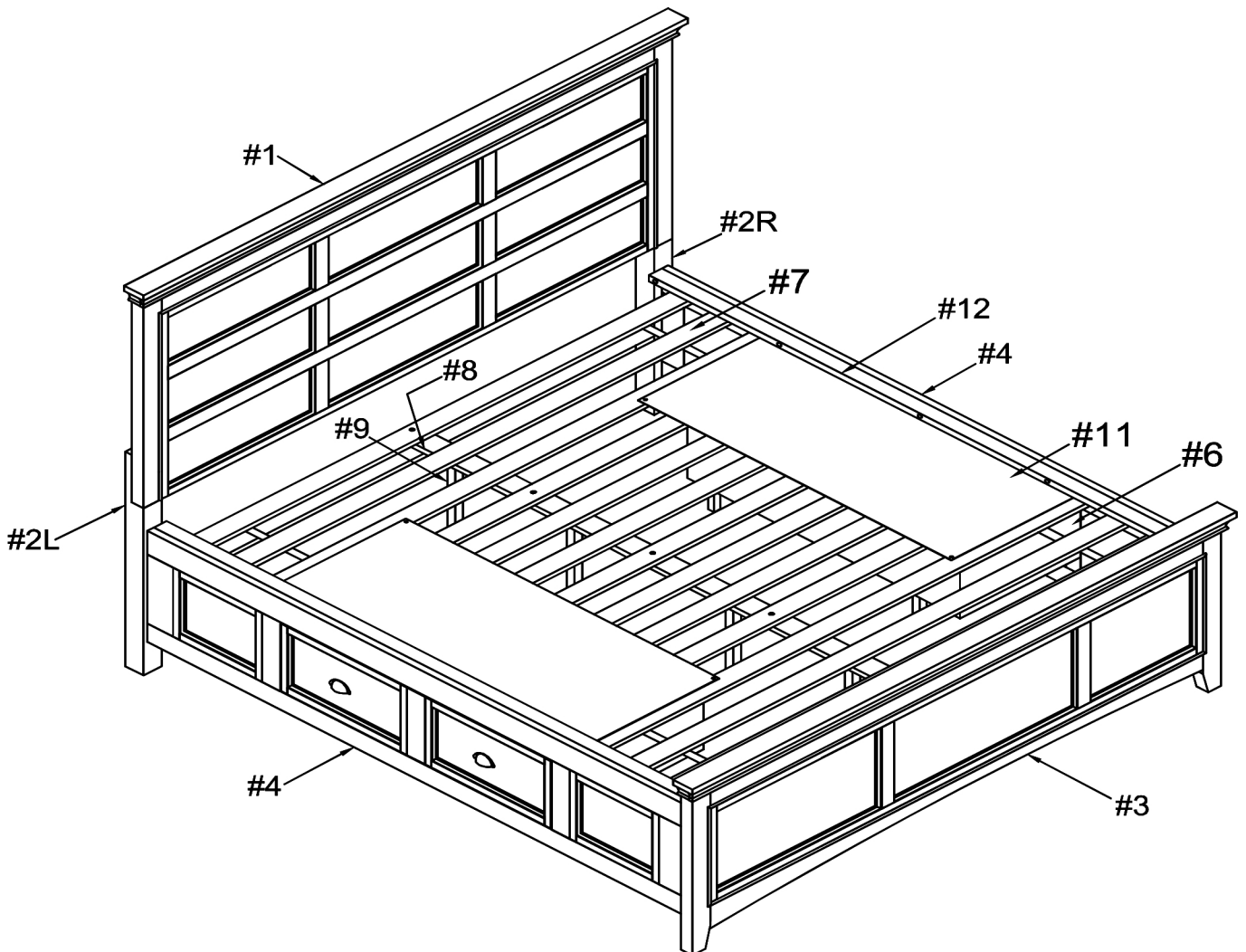



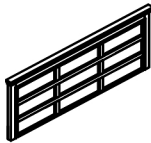





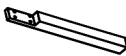
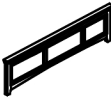
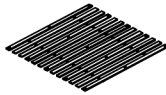
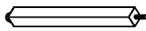

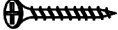

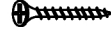

Bolt  
Ø1/4" x 1-3/4"

# Exploded view

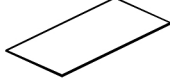
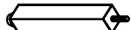
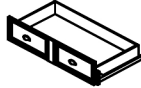

**packed in 4 caces**

Carton	Disignation	#	Part	Hardware
	Headboard Panel	#1		 #A 10pcs  #B 10pcs  #C 10pcs  #D 1pc
	HB Support	#5		
	HB Leg (L&R)	#2		
	Footboard	#3		
	Bed Slat	#7		
	Support Leg (Long)	#9		
	Slat Center Support	#8		 #E 15pcs  #F 8pcs  #G 8pcs  #H 8pcs  #I 1pc  #J 8pcs  #K 12pcs  #L 22pcs  #M 22pcs  #N 1pc  #O 10pcs
	Side Rail	#4		
	Top Side Rail	#12		
	Conceal Panel	#11		
	Support Leg (Short)	#10		
	Drawers	#6		

# ASSEMBLY INSTRUCTIONS

## 1

I. Align the L/R HB Leg (#2) to the Headboard Panel (#1) and secure using Bolts (#A) with Washers (#B,C).

I. Attach the HB Support (#5) to the HB Legs (#2) by using Bolt (#A) with washers (#B,#C).

- Part #1 x1pc
- Part #2 x2pcs
- Part #5 x1pc
- Hardware #A x10pcs
- Hardware #B x10pcs
- Hardware #C x10pcs

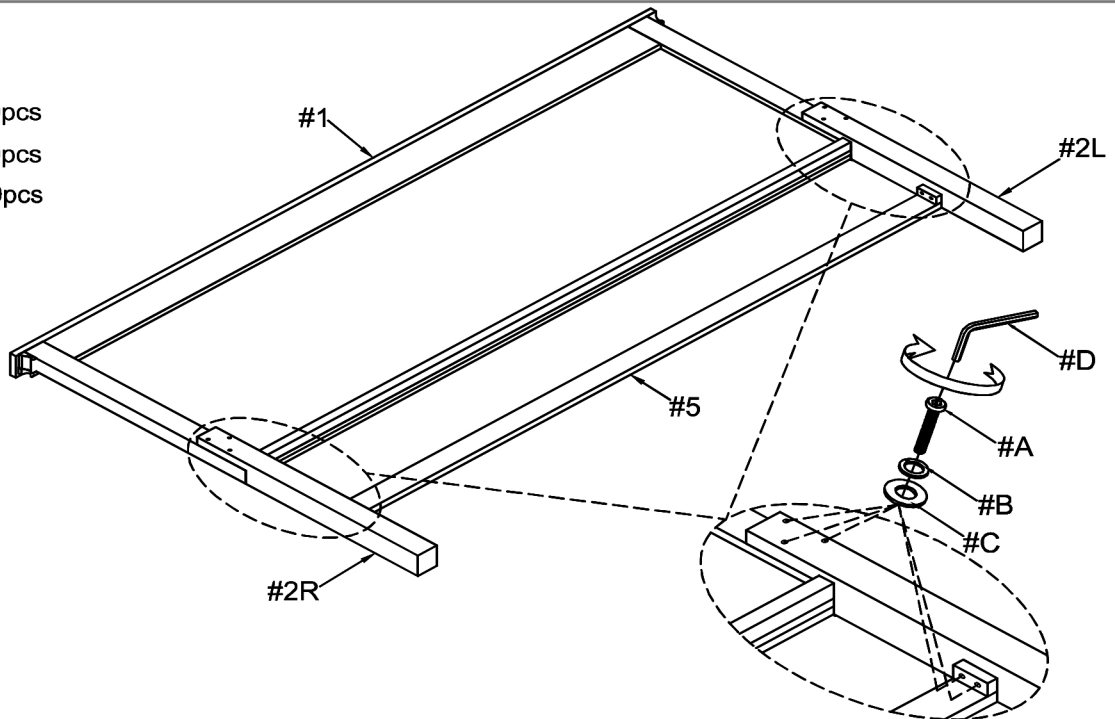

## 2

I. Attach the threaded pins (#F) to the Headboard leg (#2) and Footboard (#3).

I. Align the Side Rail (#4) onto the Headboard (#1) and Footboard (#3).

II. Secure by inserting the Half Moon Washer (#H) with the Hex Nut (#G). Use wrench (#I) to tighten the Hex Nut (#G).

- Part #3 x1pc
- Part #4 x2pcs
- Hardware #F x8pcs
- Hardware #G x8pcs
- Hardware #H x8pcs

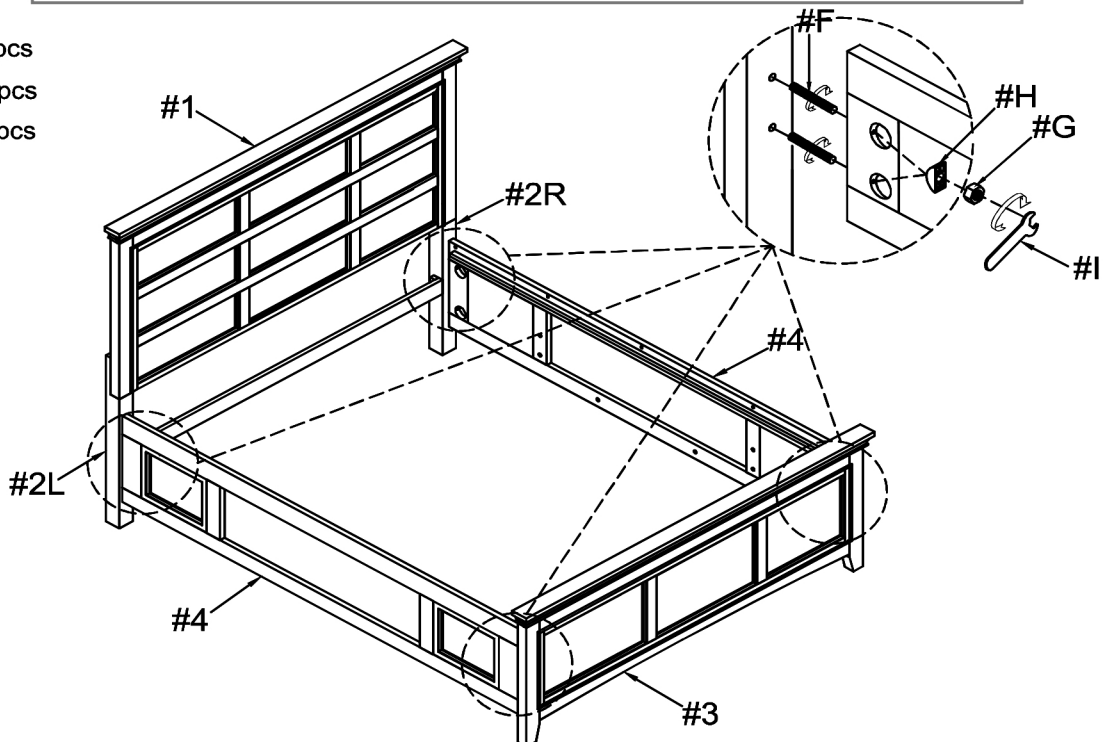

# ASSEMBLY INSTRUCTIONS

## 3

- Part #6 x1pc
- Part #10 x2pcs

Attach the Short Support Leg (#10) to the Drawer (#6). Adjust the leveler height for the the leg to reach the floor.

# x 2

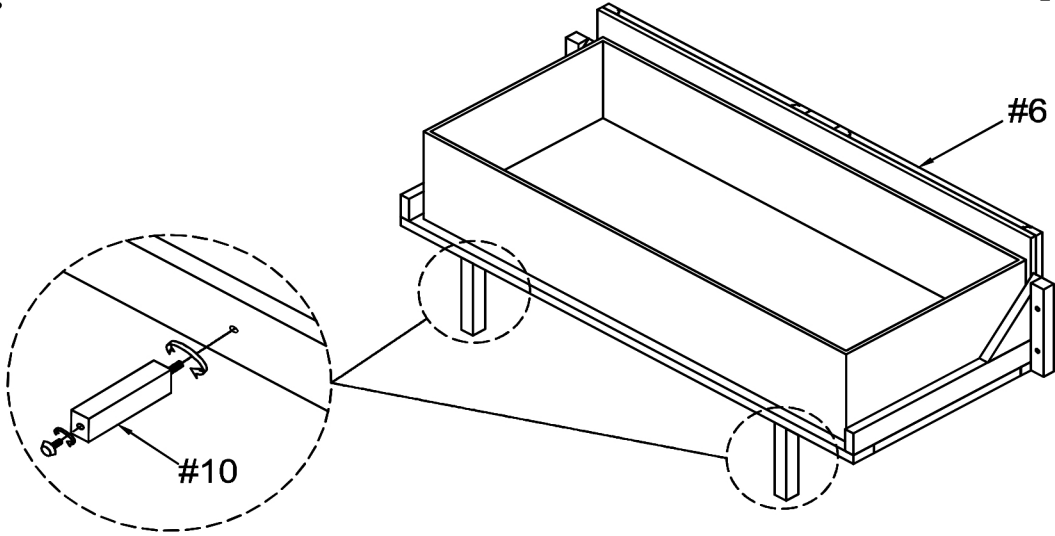

## 4

- Hardware #K x8pcs
- Hardware #L x8pcs
- Hardware #M x8pcs

Align the Drawer (#6) to the Side rails (#4) and secure using Bolt (#K) with washers (#L,M).

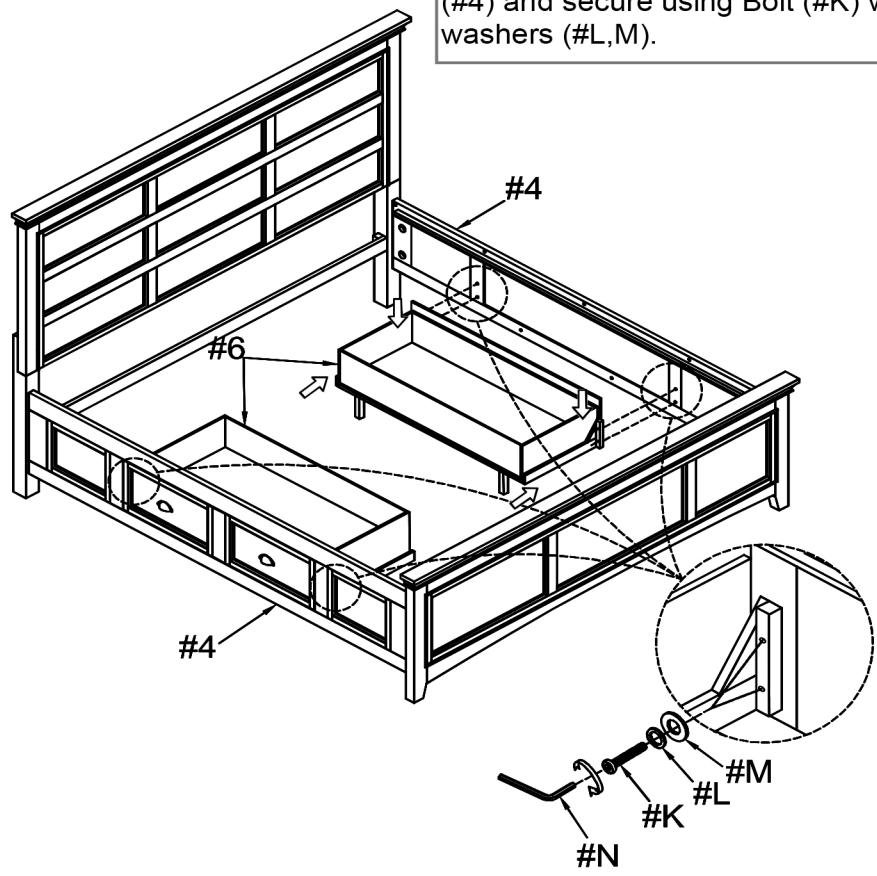

# ASSEMBLY INSTRUCTIONS

## 5

- Hardware (#K) x4pcs
- Hardware (#L) x4pcs
- Hardware (#M) x4pcs

Extend the Drawer out and secure the support frame to the Side Rail (#4) by using Bolts (#K) with washers (#L, #M).

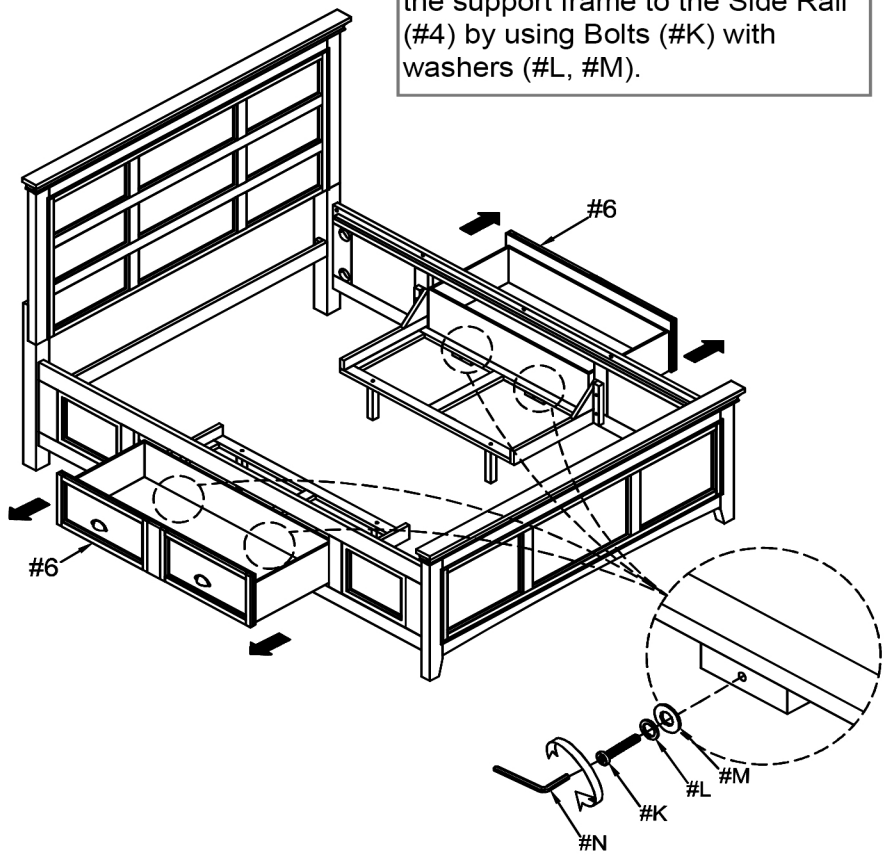

## 6

- Part (#8) x1pc
- Part (#9) x4pcs

Attach the Long Support leg (#9) to the Slat Center Support (#8). Use levelers to adjust height of the support leg.

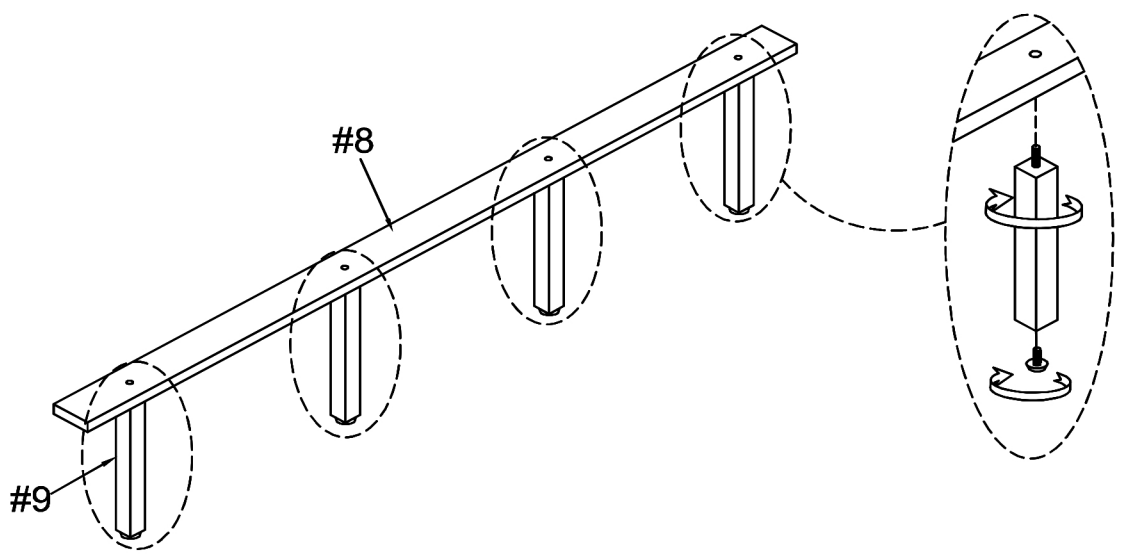

# ASSEMBLY INSTRUCTIONS

## 7

Part (#7) x1set  
Hardware (#E) x15pcs

I. Attach the Center Support (#8) to the bed Slat set (#7).  
I. Align Bed slats (#7) to the Side rails (#4) and secure using Screw (#E).

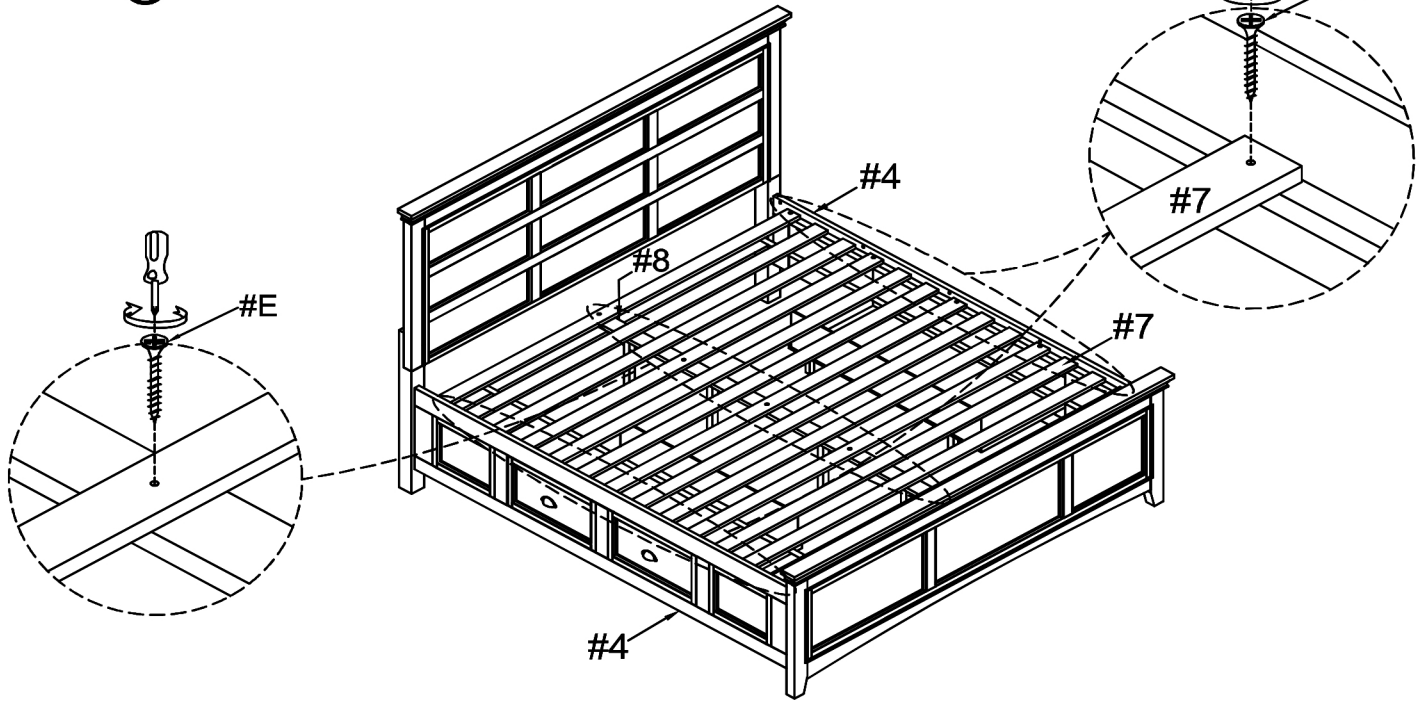

## 8

Part (#11) x2pcs  
Hardware (#J) x8pcs

Attach the conceal panel (#11) to the slats by using screw(#E).

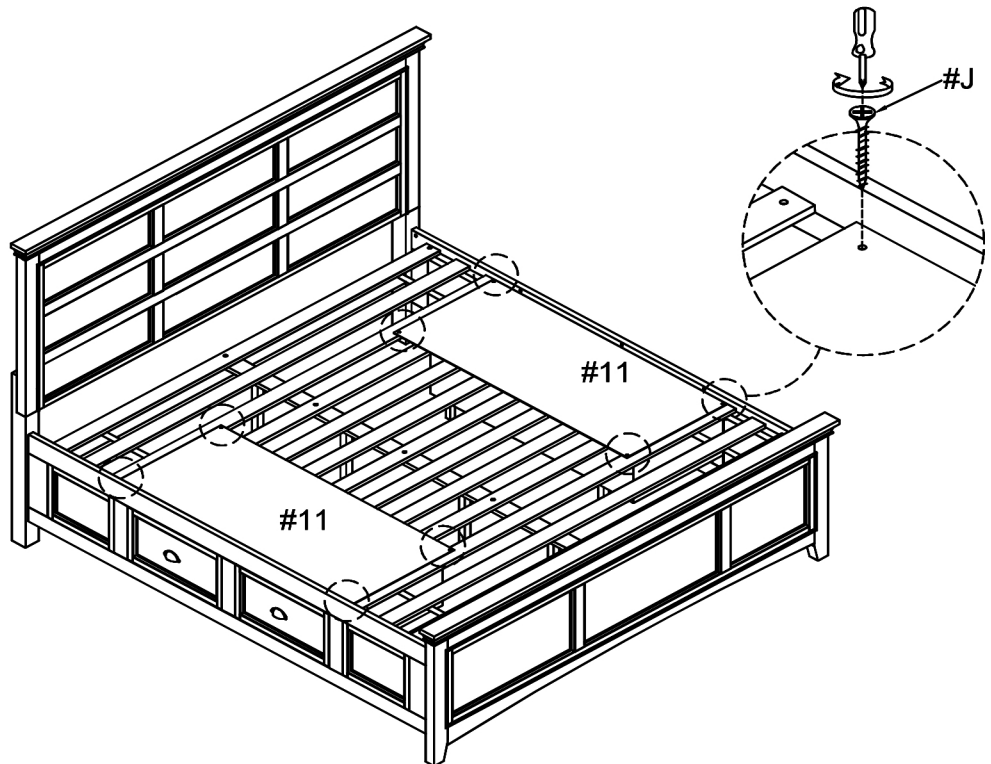

# ASSEMBLY INSTRUCTIONS

## 9

Part #12 x2pcs

Hardware #O x10pcs

Hardware #L x10pcs

Hardware #M x10pcs

Align Top side rail (#12) and secure by using Bolt (#O) with washers (#L,M).

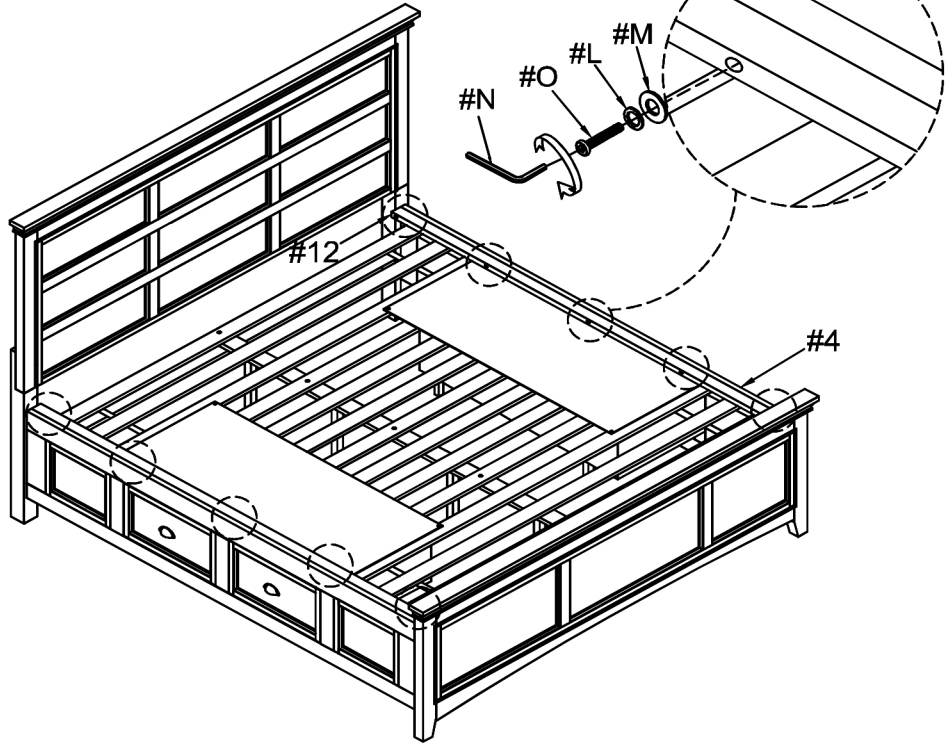

## 10

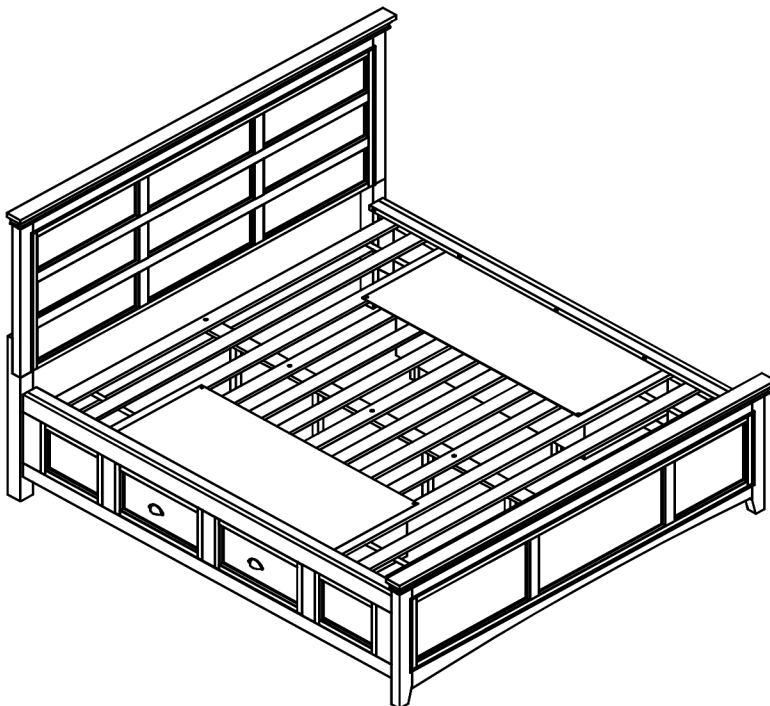

## ASSEMBLY COMPLETED



Please ensure the furniture rests on an even and flat surface. If the product wobbles or feels loose, double-check all bolts and/or screws are properly tightened and secured.



### Keep this handy!

Please retain this instruction manual and any order-related information for future reference.



### Lift, don't drag!

To avoid damage to product please always LIFT the product when transporting or adjusting the placement.