

Outdoor Storage Shed8X6ft Manual

Dear customer,

Thank you for your support.If you have any questions or concerns,please don't hesitate to contact us. Our customer service team is always here to help and assist you in any way we can. Thank you again for choosing our chicken coop.

Street: 8 The Green Suite A

City: Dover State: DE

Post code:19901

Phone:3022415039/
6605538327

Email: easyhelpservice@yahoo.com

Scan the code on your phone and
contact us via email.

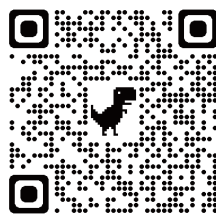

sannwsg.com

After-sales phone service hours:

US CentralTime: 19:00-23:00

Seattle time: 17:00-21:00

US EasternTime: 20:00-00:00

Toronto time: 20:00-00:00

Germany time: 8:00-11:00

After-sales mailbox service time:
7*24 hours

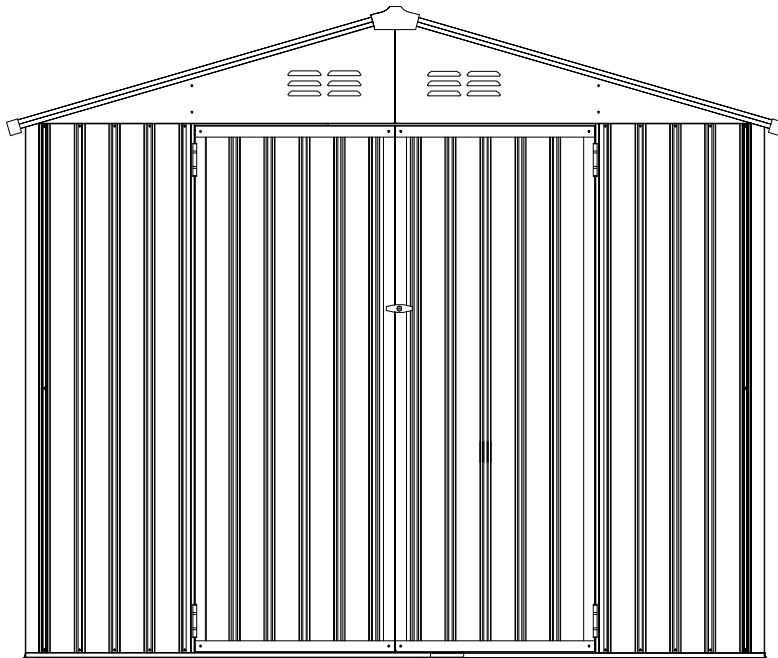

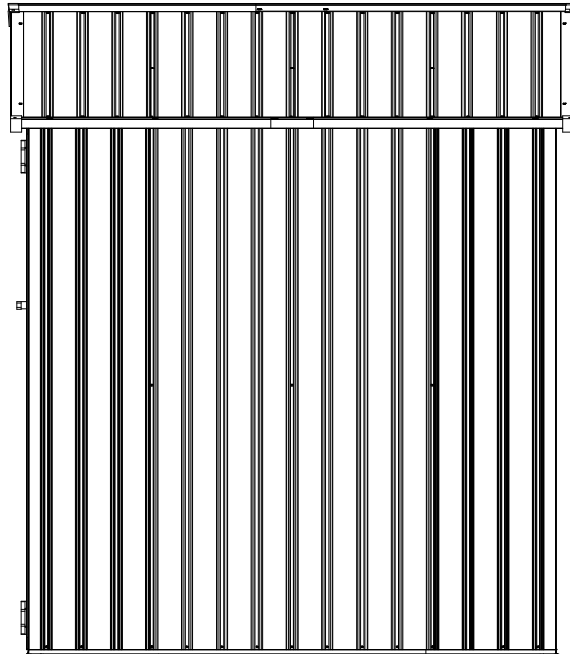

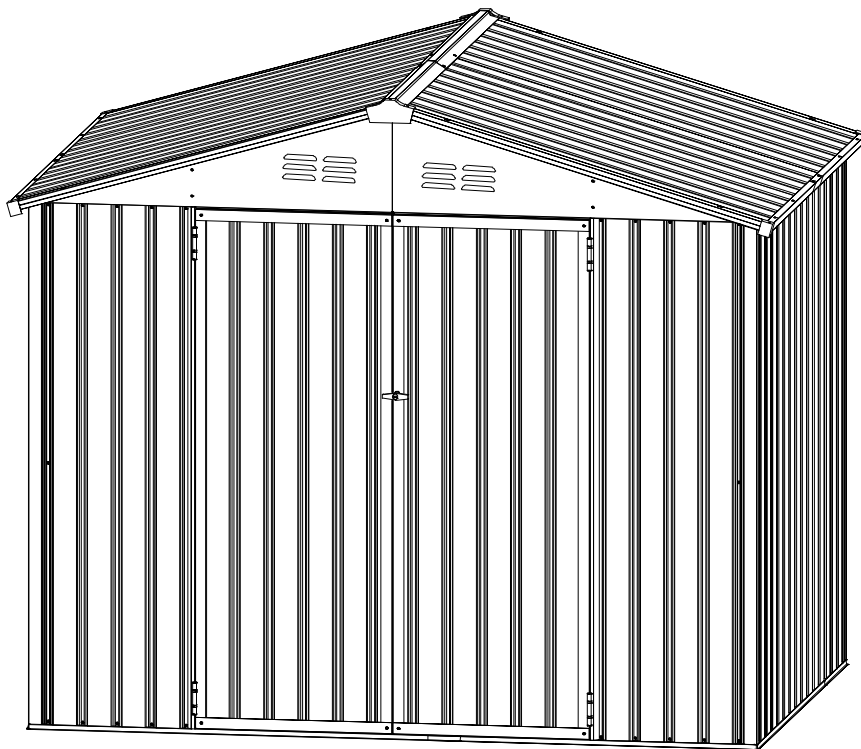

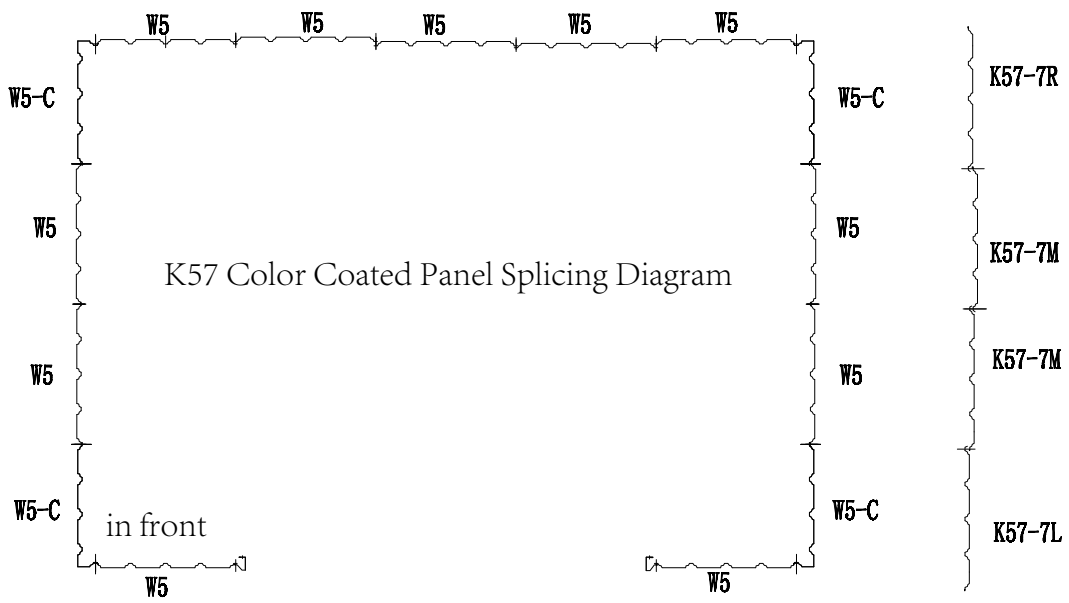

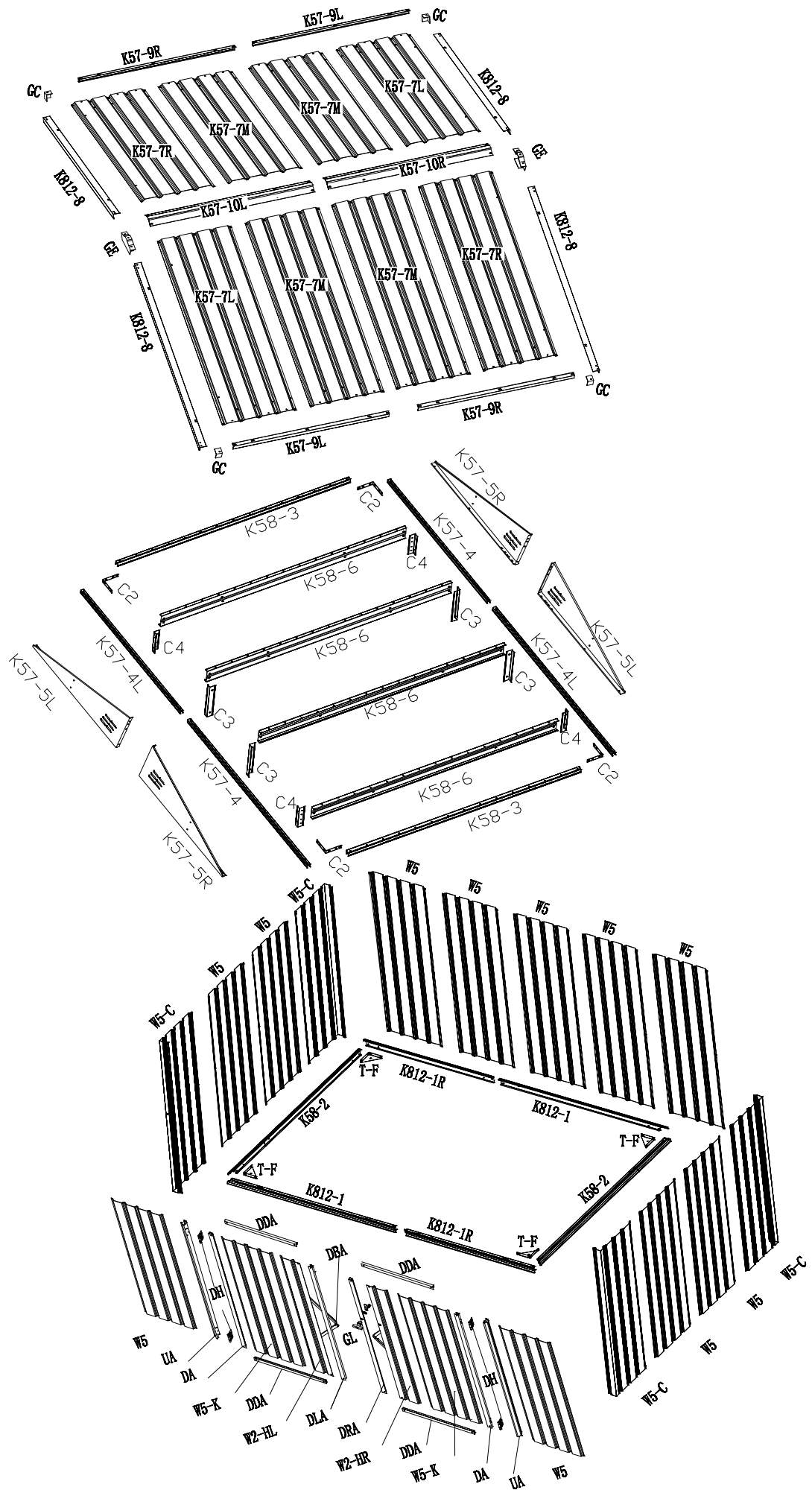





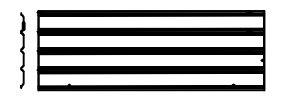
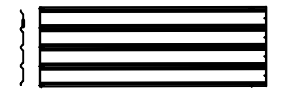

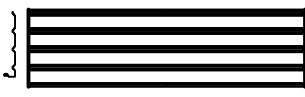

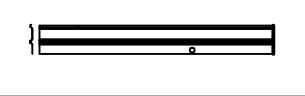



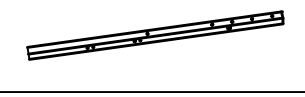
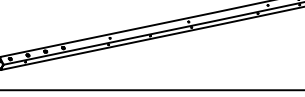
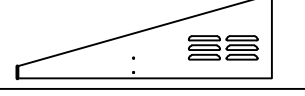
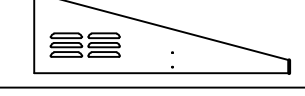

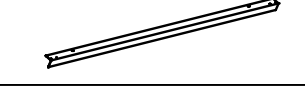

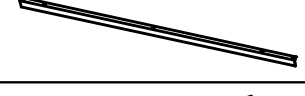
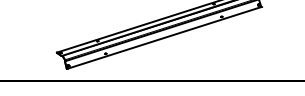

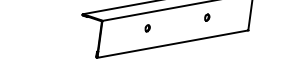

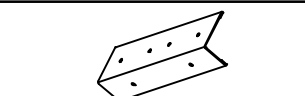

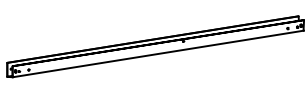
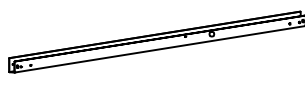
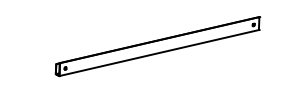

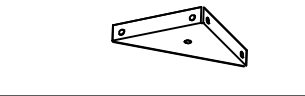
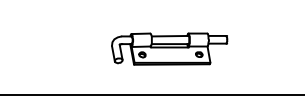
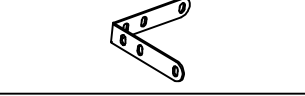
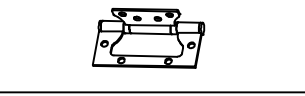

K57parts list

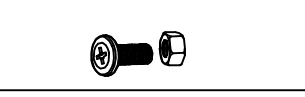
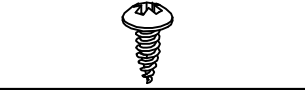
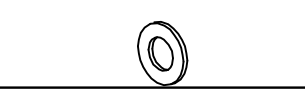
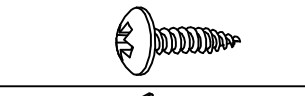
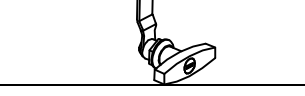
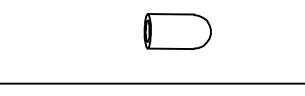

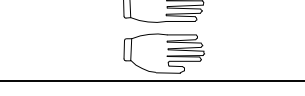
PART	NO.	QTY.
	W5	11
	W5-K	2
	K57-7L	2
	K57-7M	4
	K57-7R	2
	W5-C	4
	W2-HL	1
	W2-HR	1
	K812-1	2
	K812-1R	2
	K58-2	2
	K58-3	2
	K57-4L	2
	K57-4	2
	K57-5L	2
	K57-5R	2
	K58-6	4
	K812-8	4
	K57-9L	2
	K57-9R	2
	K57-10L	1
	K57-10R	1
	UA	2
	C3	4

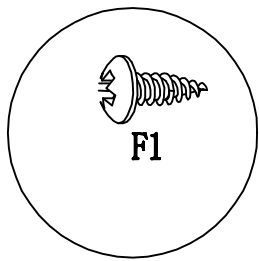
PART	NO.	QTY.
	C4	4
	DA	2
	DLA	1
	DRA	1
	DDA	4
	DBA	4
	GC	4
	GE	2
	T-F	4
	DC	2
	C2	4
	DH	4
	F1	318
	F2	36
	F3	32
	V2	132
	F4	4
	GL	1
	SL	38
	M20	1
	ST	2



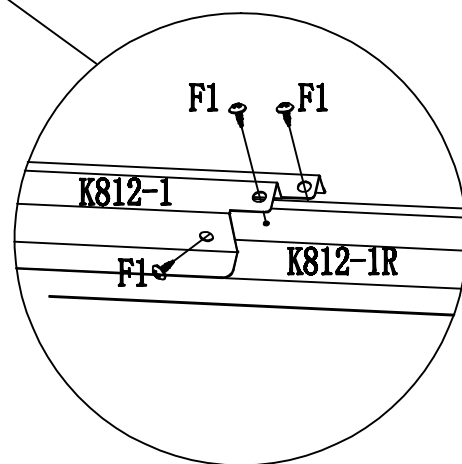
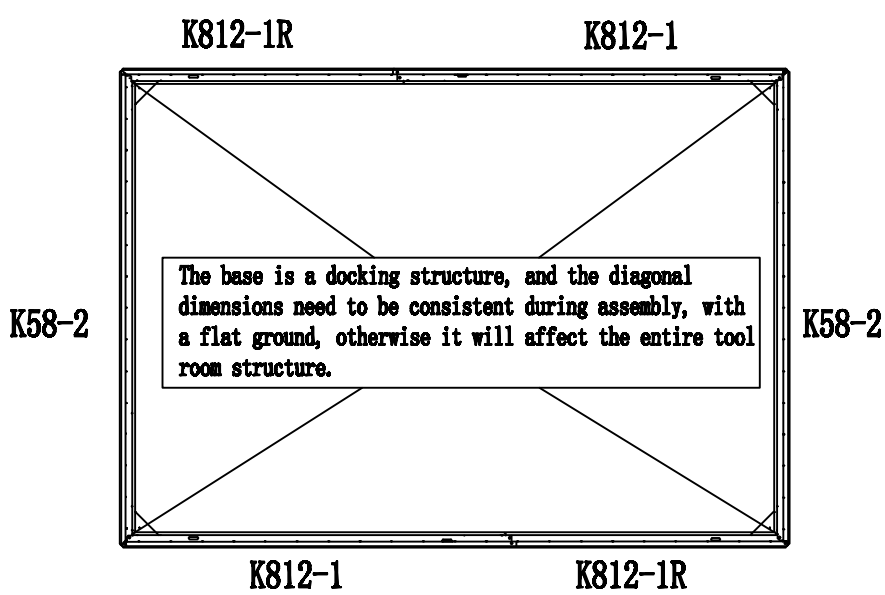
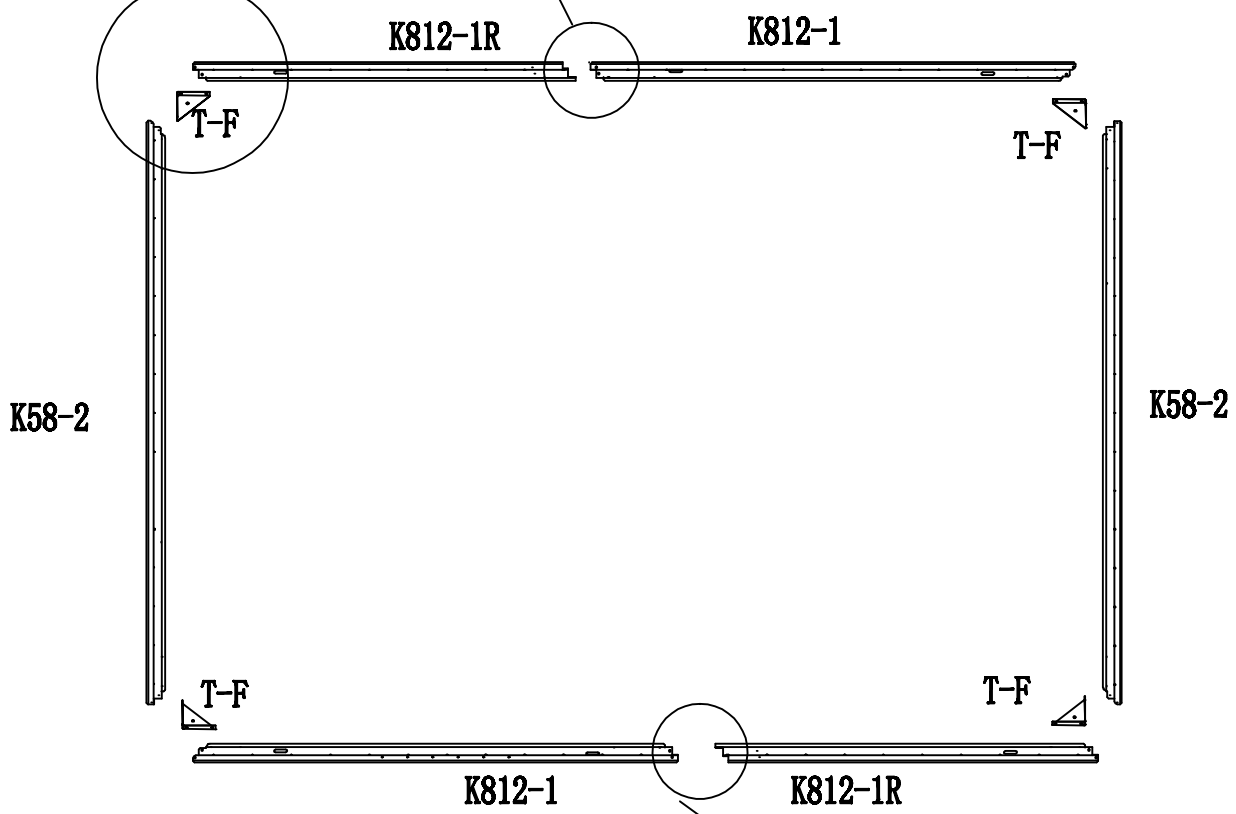
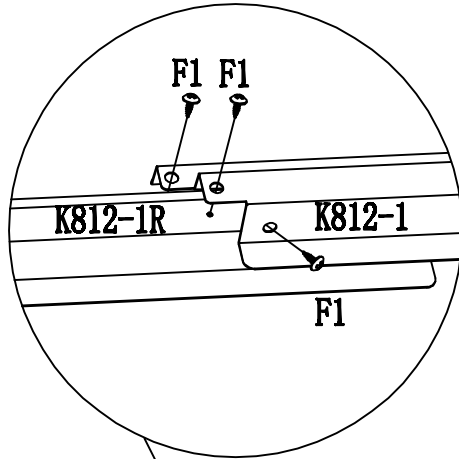
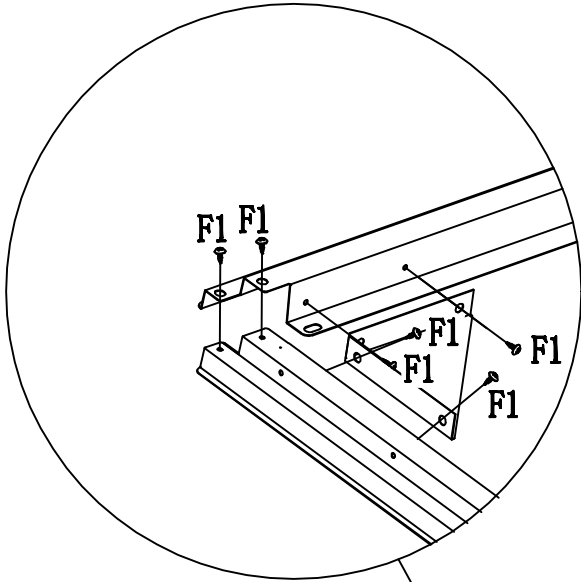

PART	NO.	QTY.
	K812-1	2
	K812-1R	2
	K58-2	2
	T-F	4
	F1	30



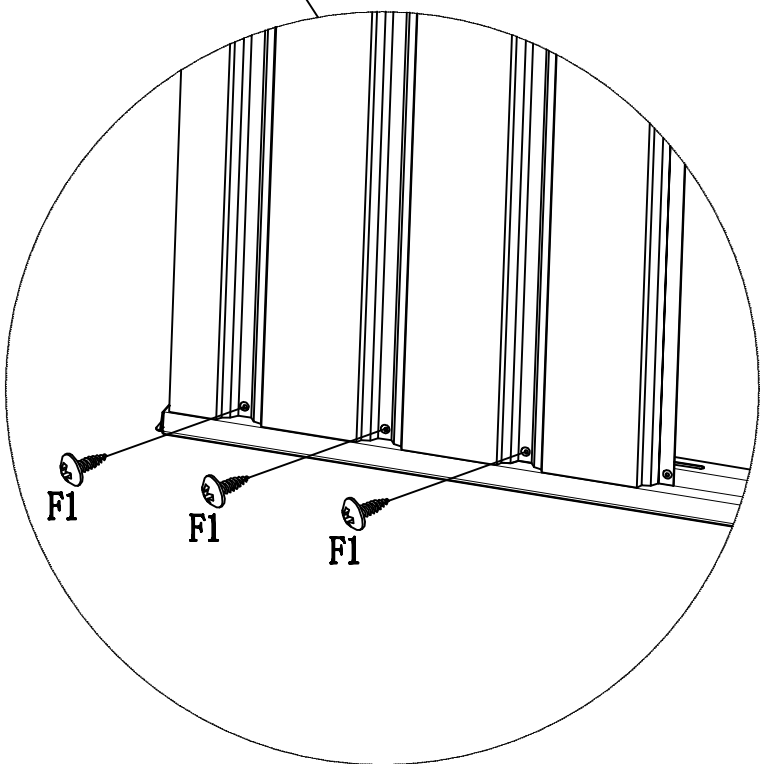
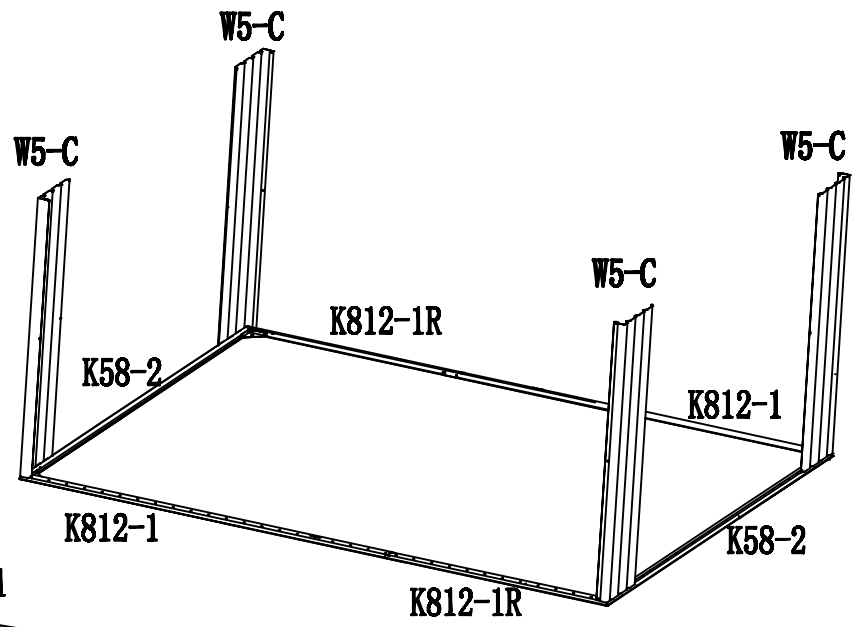
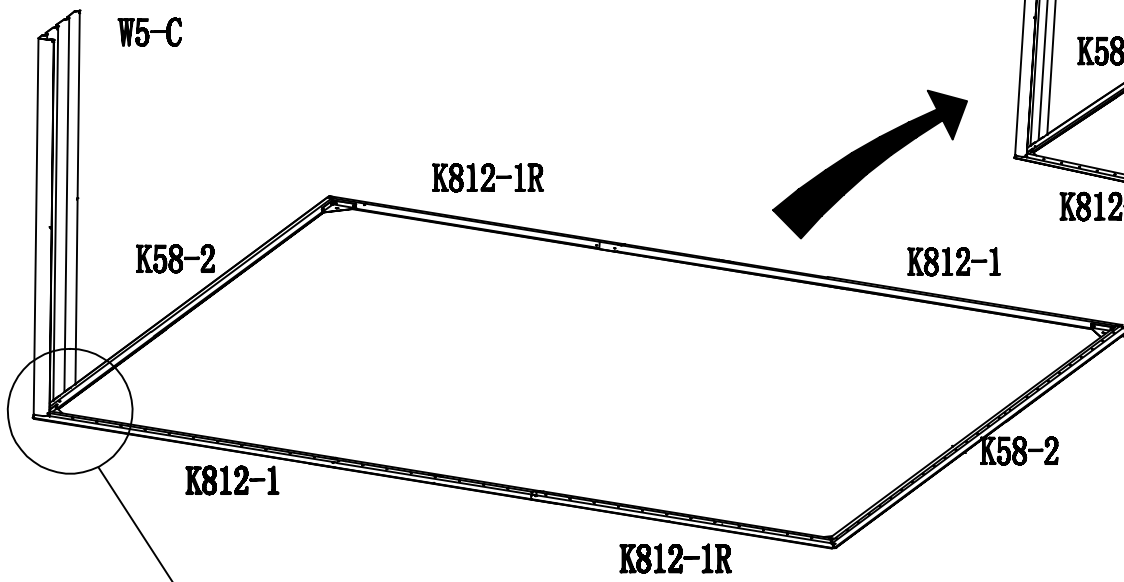
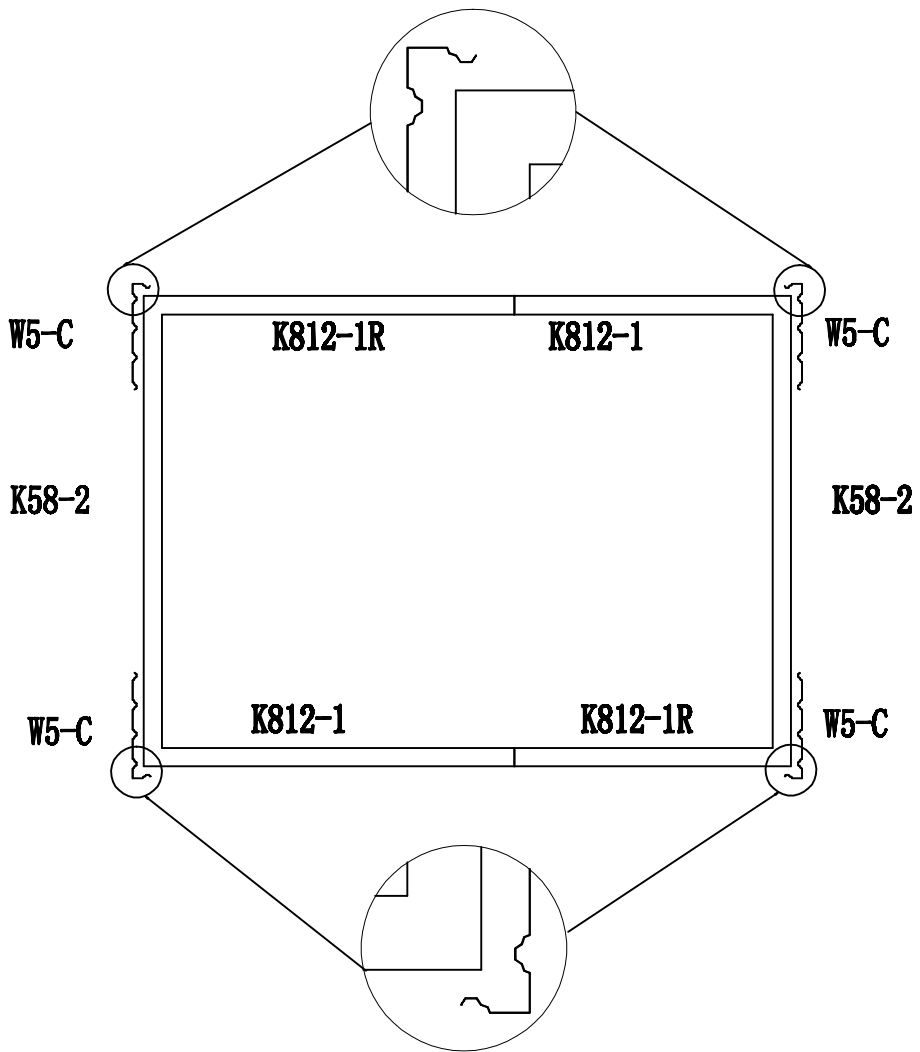

PART	NO.	QTY.
	W5-C	4
	F1	12





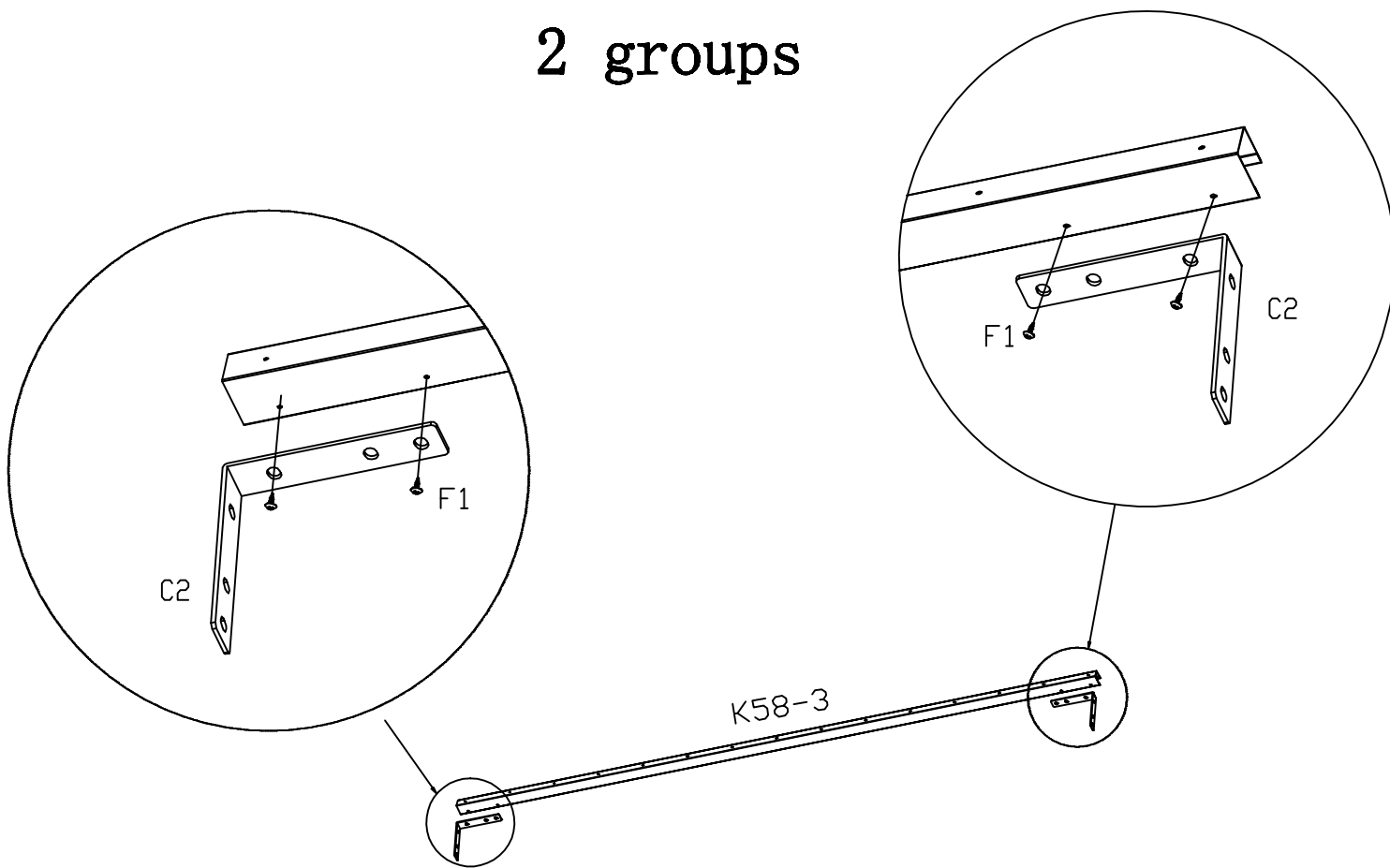

PART	NO.	QTY
	K58-3	2
	C2	4
	F1	8

2 groups

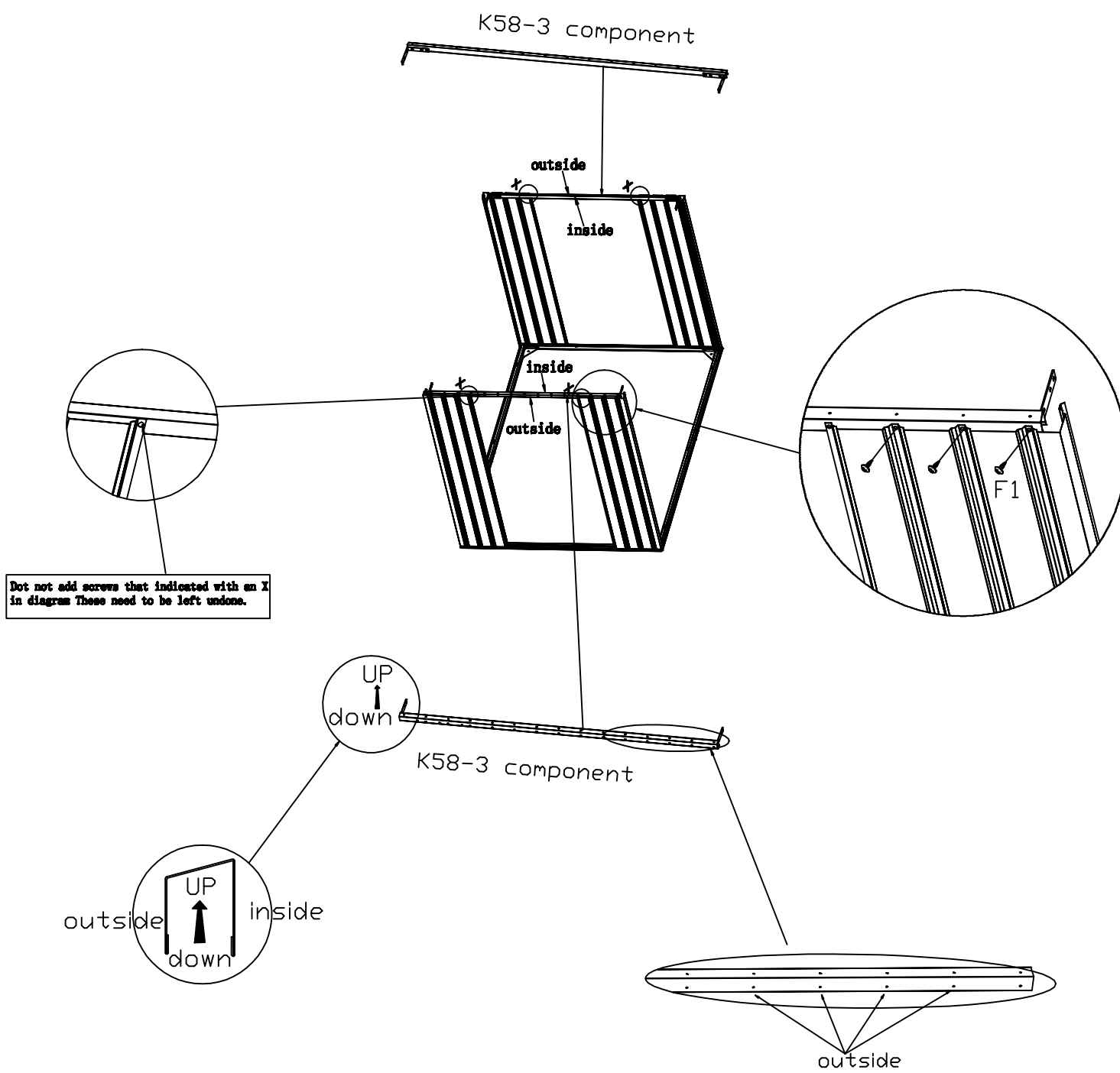





PART	NO.	QTY
	K58-3 component	2
	F1	12

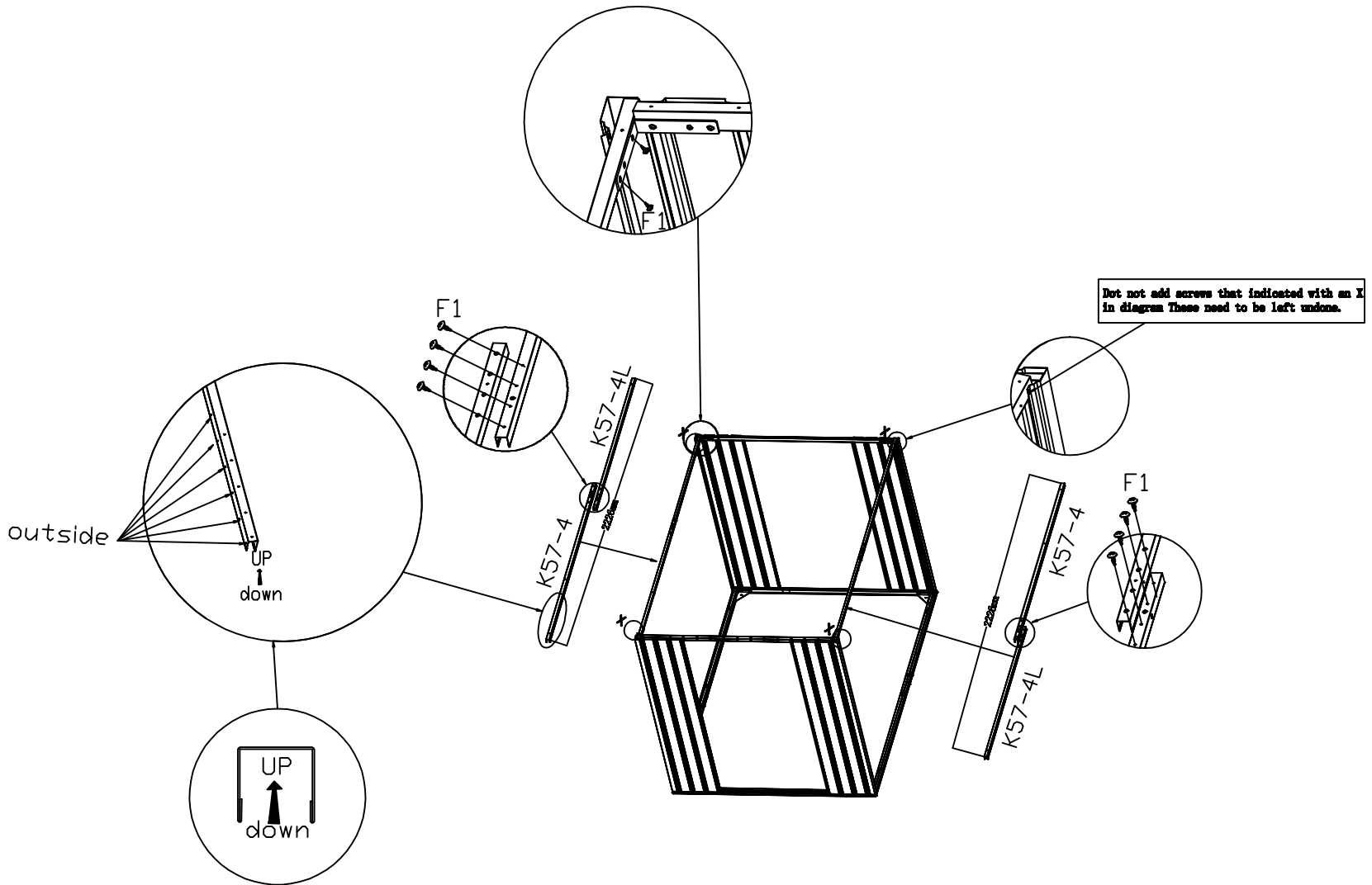

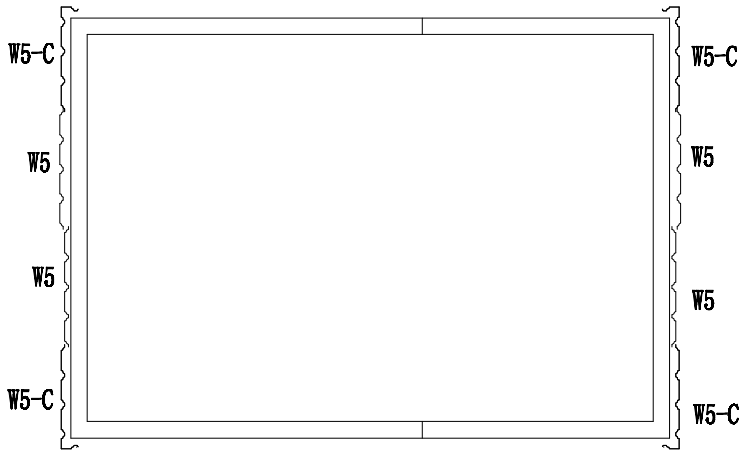
PART	NO.	QTY
	K57-4L	2
	K57-4	2
	F1	16







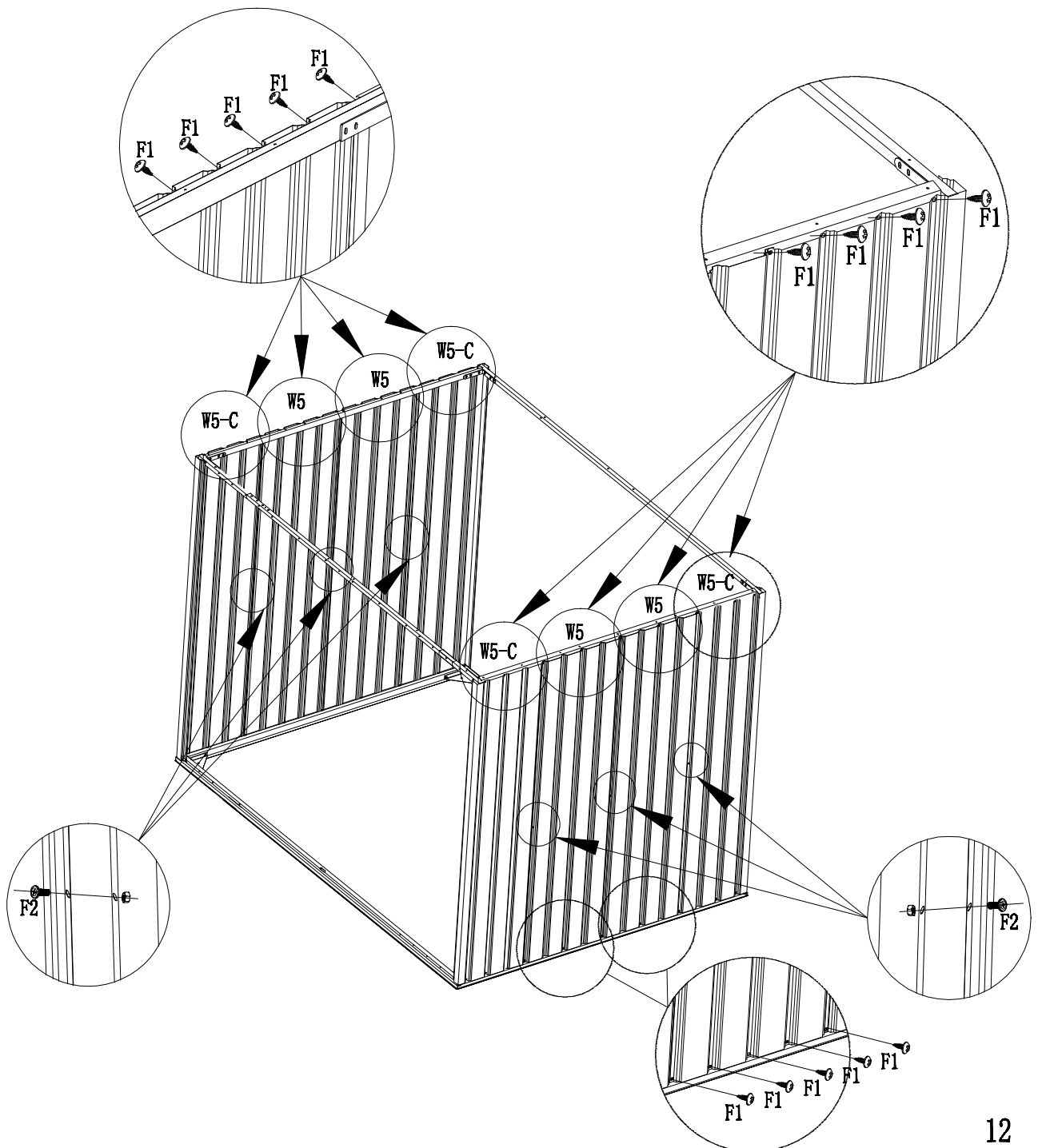

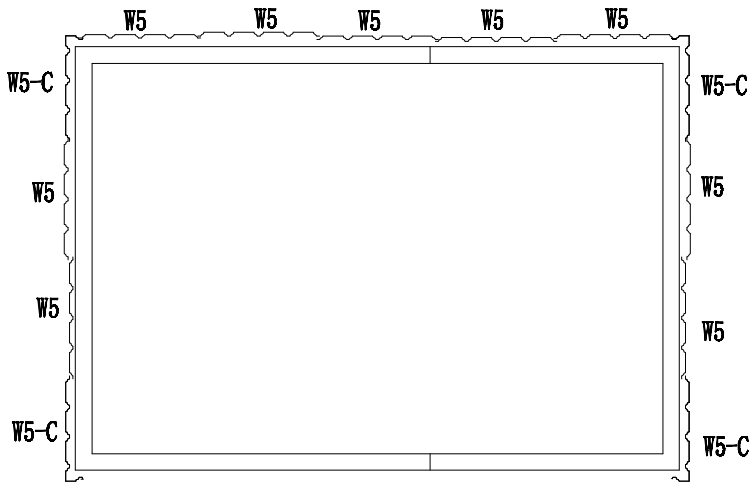

PART	NO.	QTY.
	W5	4
	F1	36
	F2	6



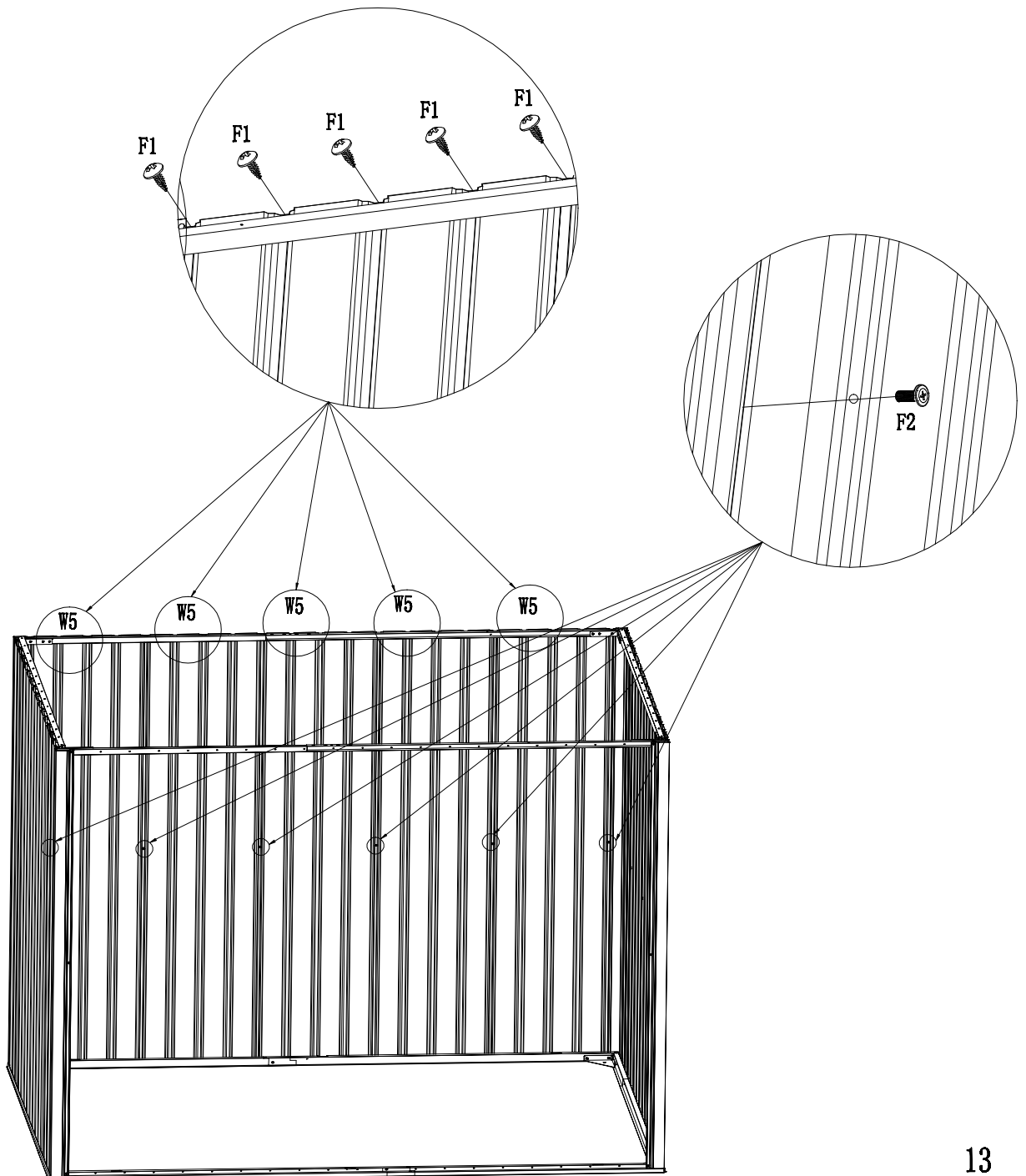





PART	NO.	QTY.
	W5	5
	F1	42
	F2	6

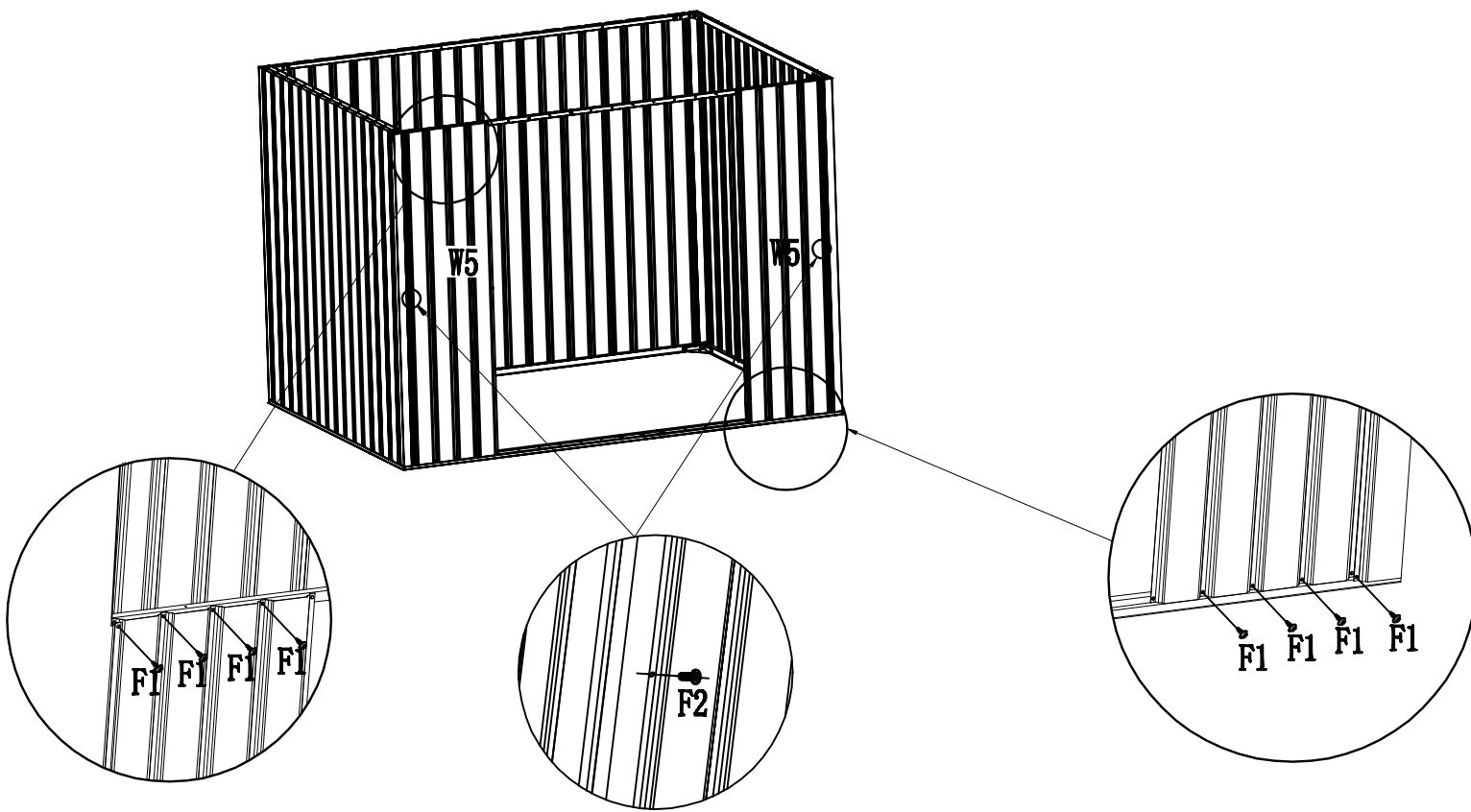
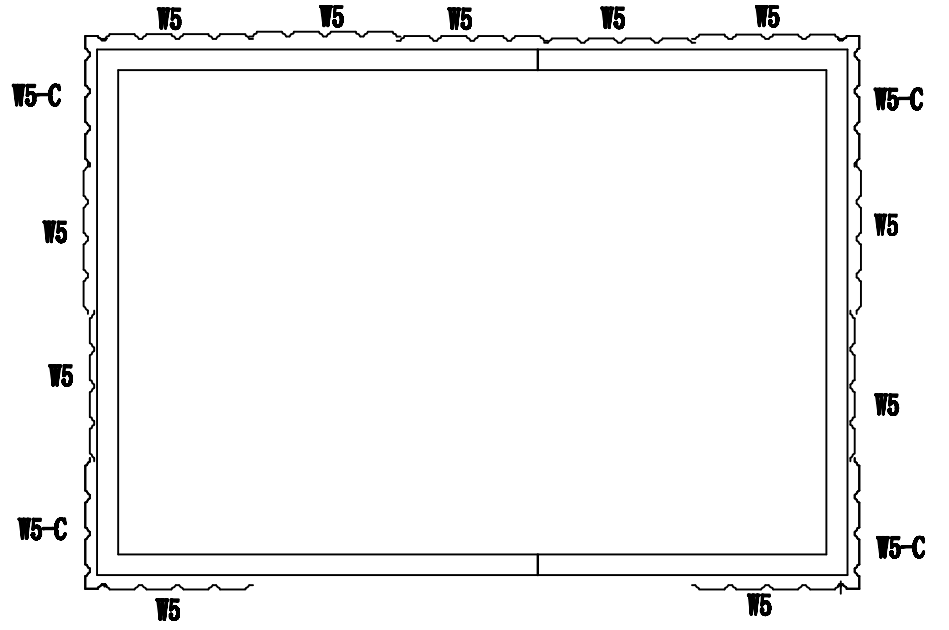

PART	NO.	QTY.
	W5	2
	F1	16
	F2	2



PART	NO.	QTY.
	UA	2
	F1	8
	F2	2

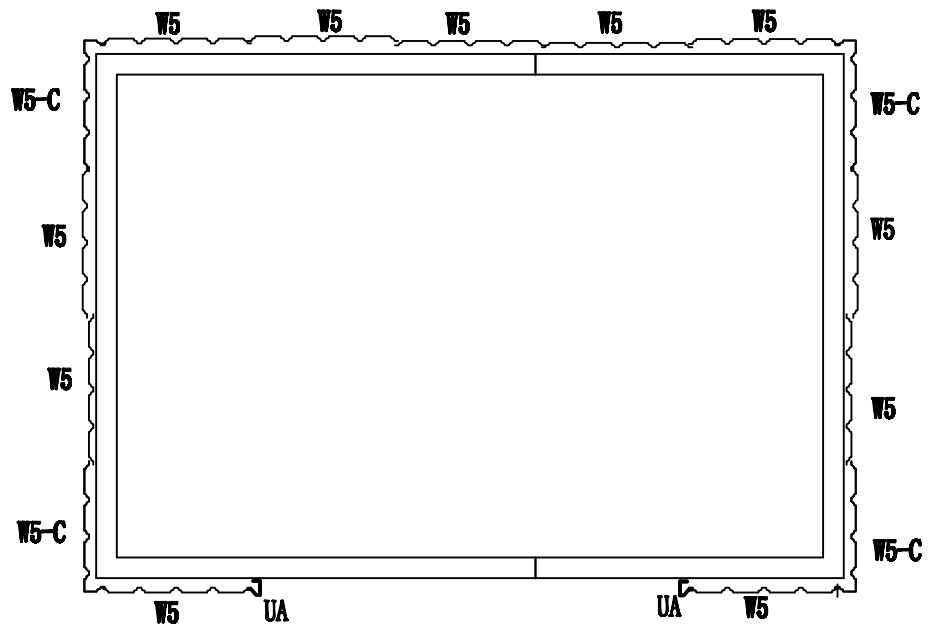

① UA notch is inserted into K57-4L/K57-4.

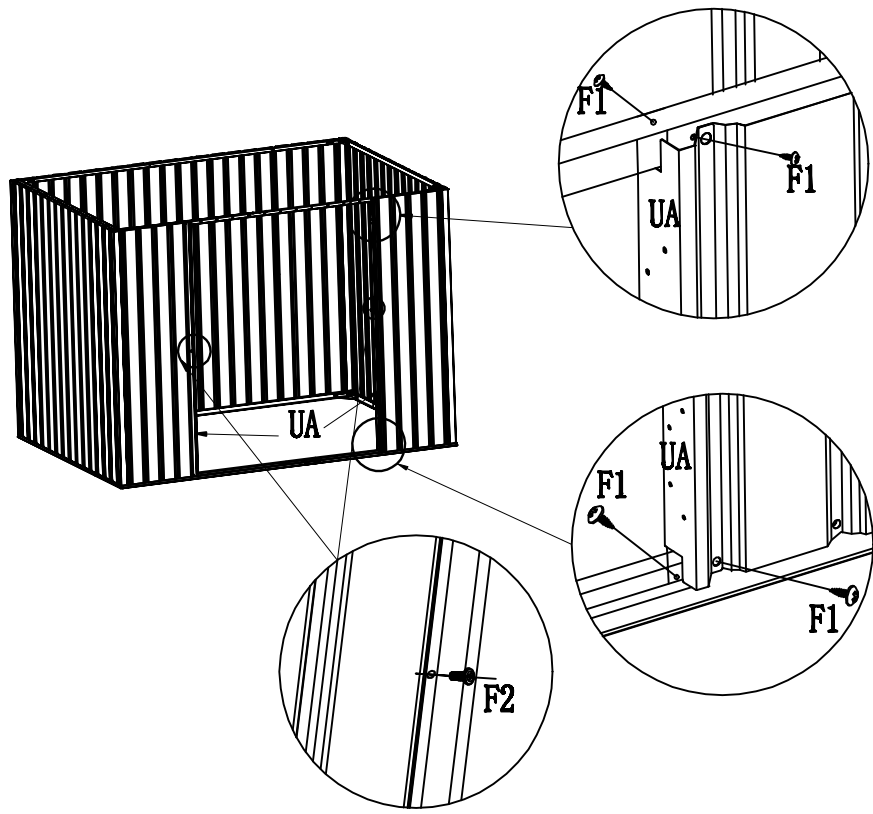
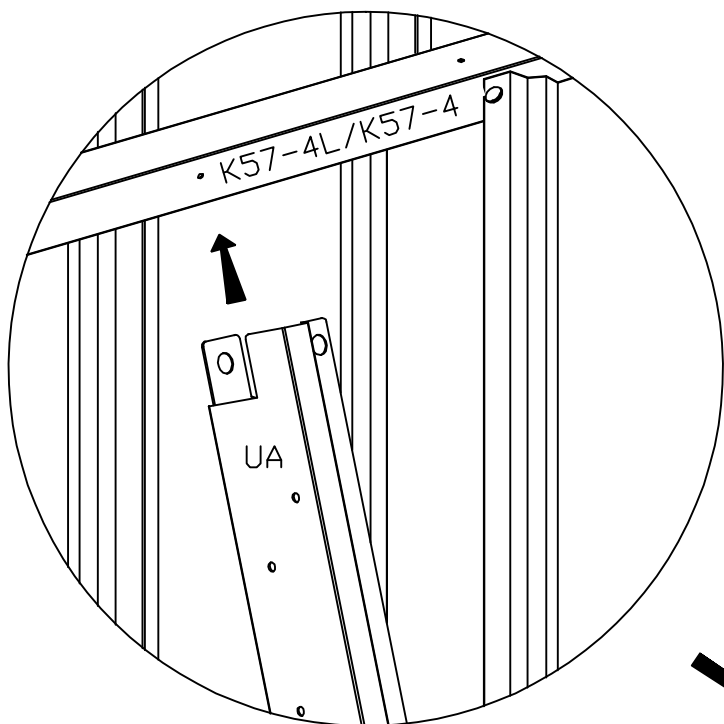

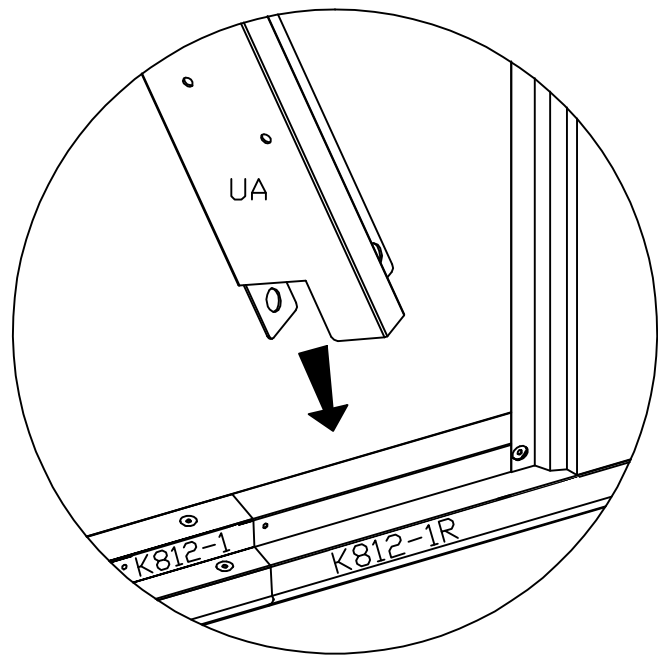

④ F1 screw fixation



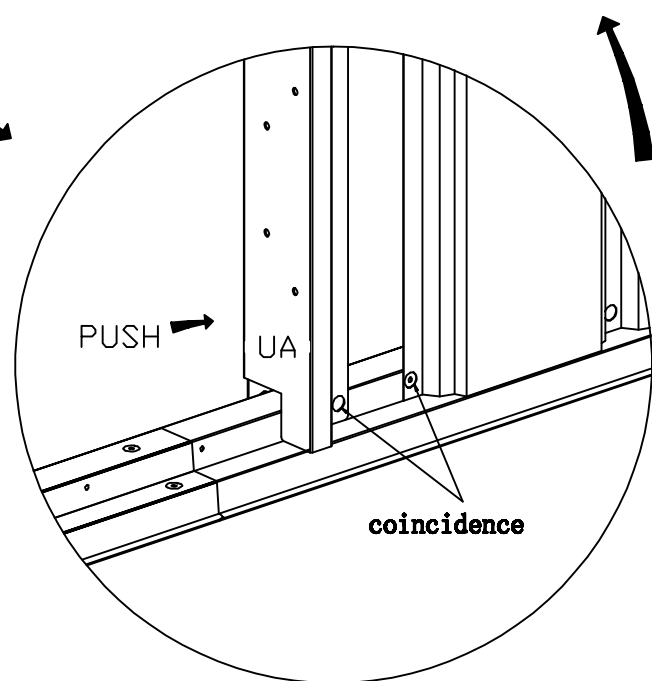

② UA notch is inserted into K812-1/K812-1R.

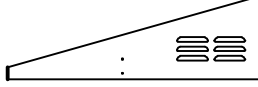
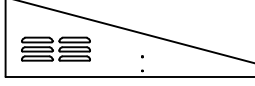



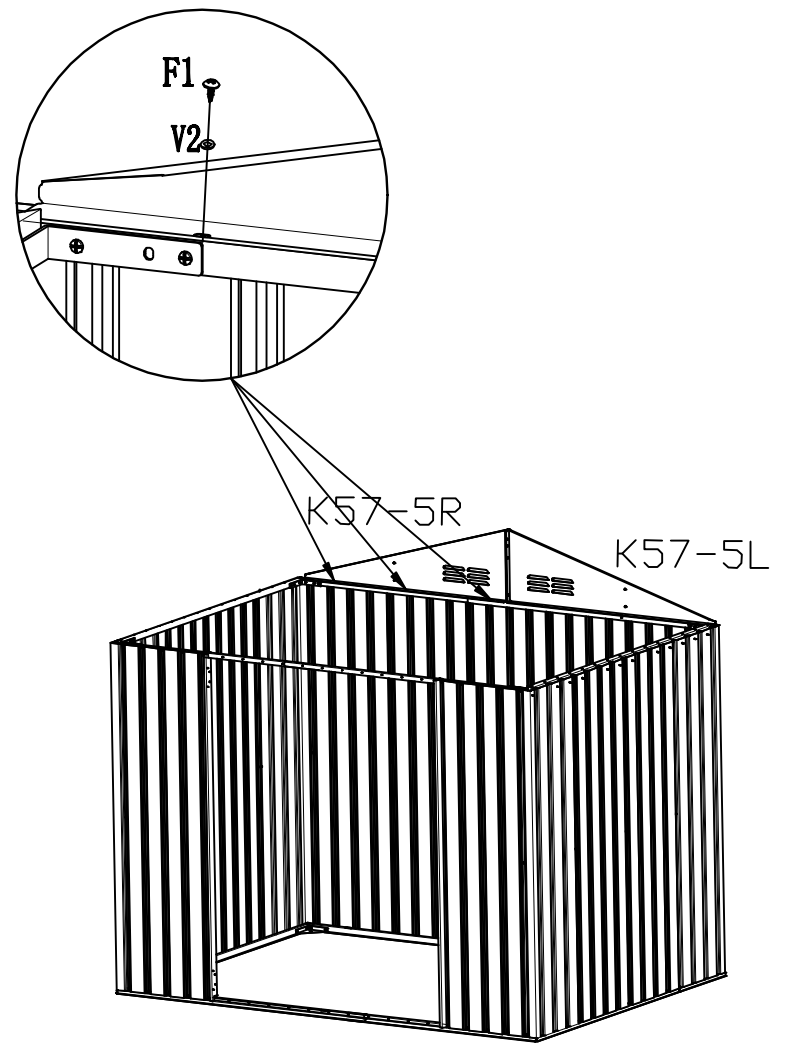
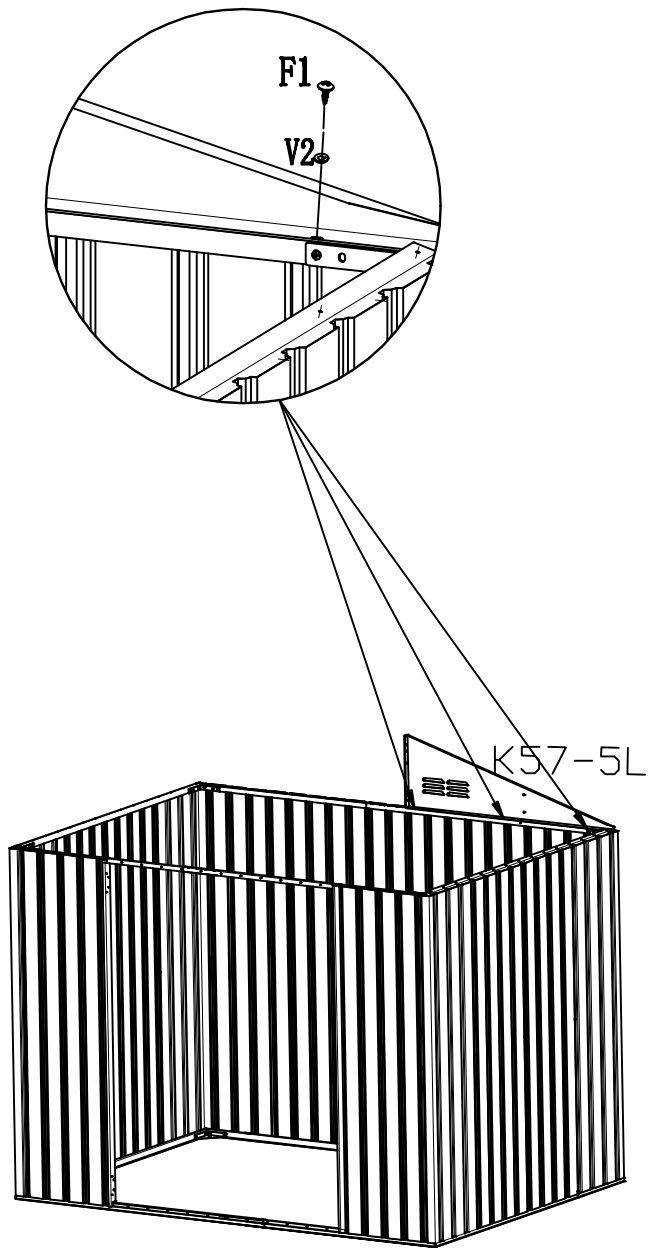

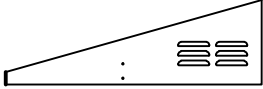
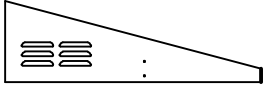
③ Push UA and W5 screw holes to coincide.

PART	NO.	QTY.
	K57-5L	2
	K57-5R	2
	F1	6
	V2	6

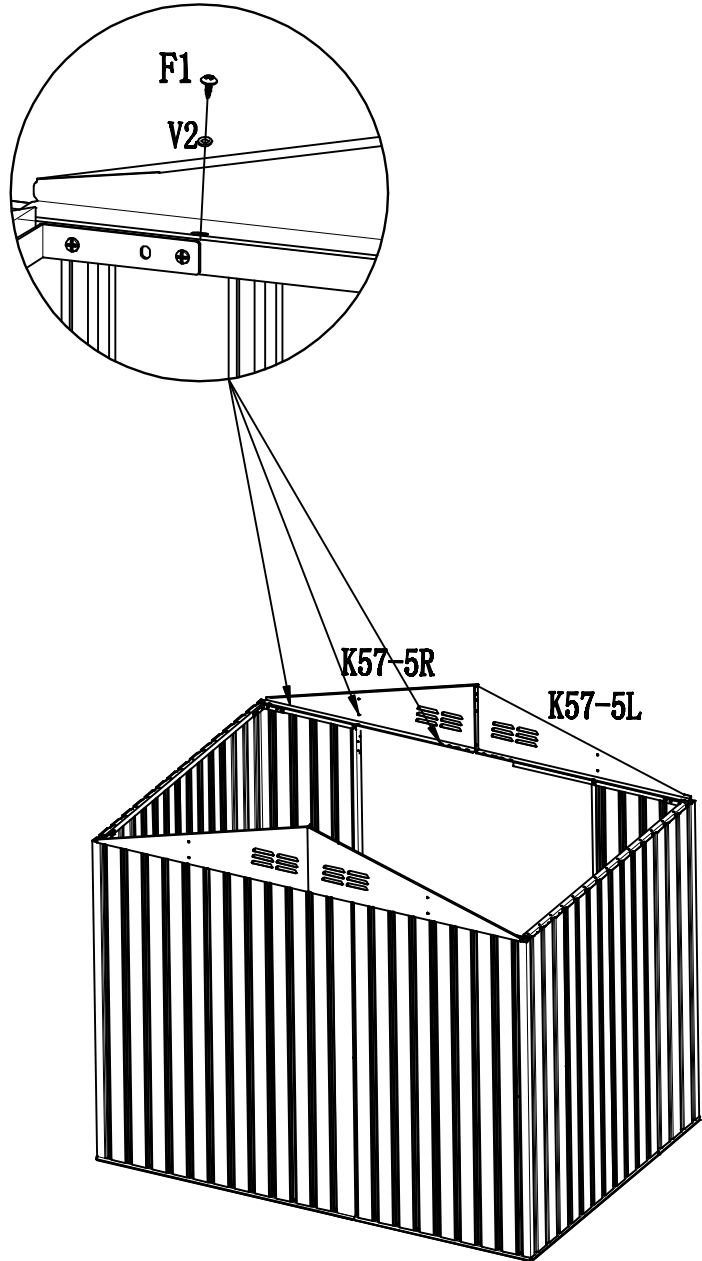
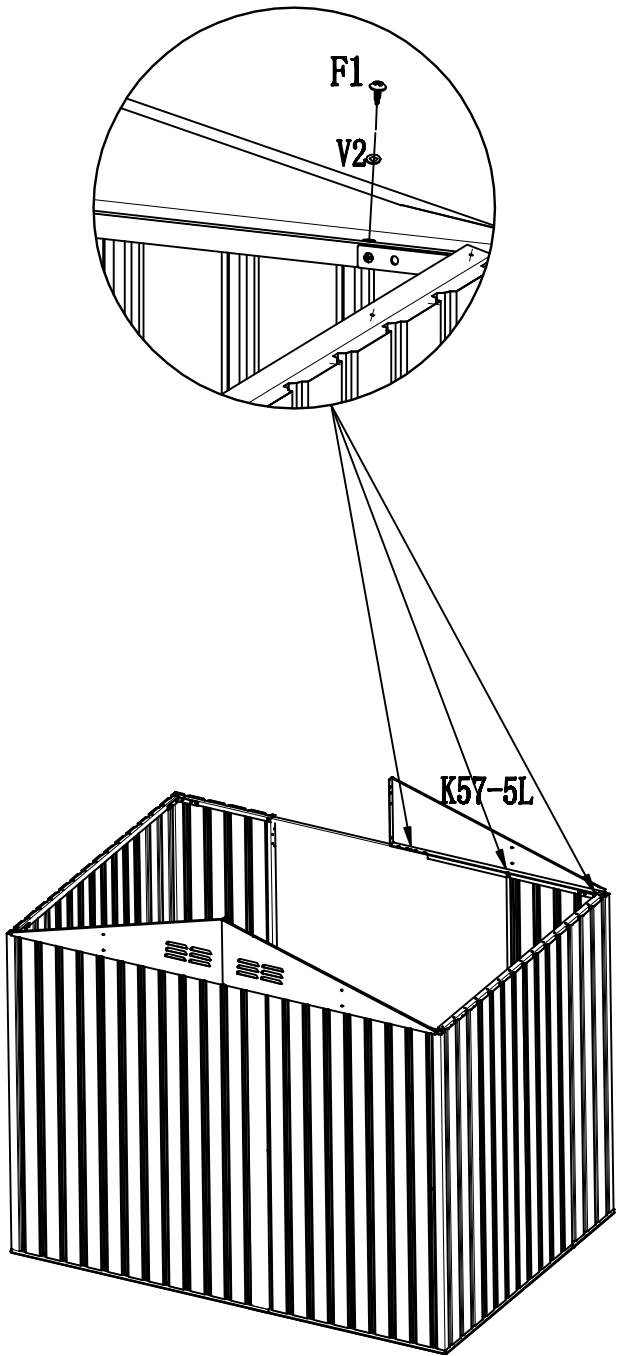





PART	NO.	QTY.
	K57-5L	1
	K57-5R	1
	F1	6
	V2	6

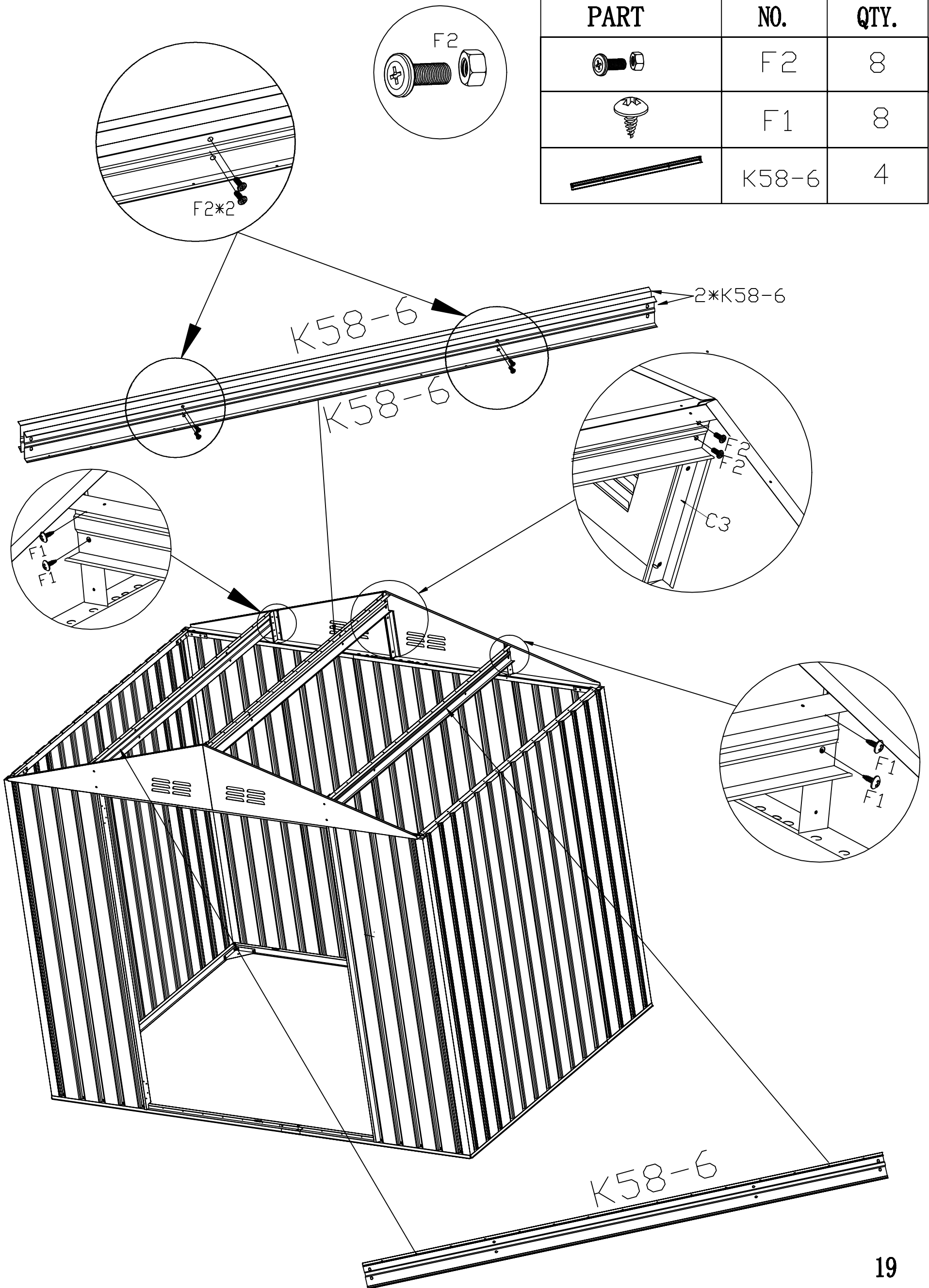

PART	NO.	QTY.
	F2	8
	F1	8
	K58-6	4



K57-7R K57-7M K57-7M K57-7L

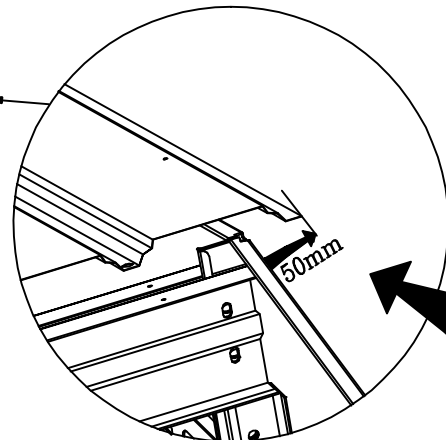
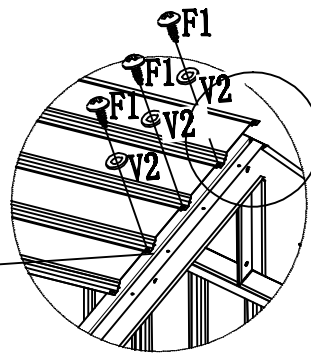
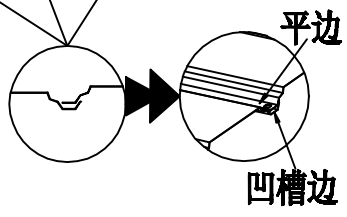
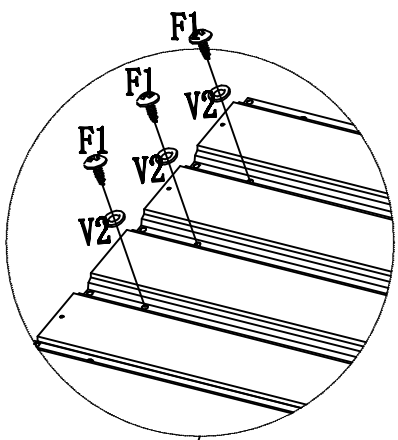

PART	NO.	QTY.
	K57-7L	2
	K57-7M	4
	K57-7R	2
	F1	60
	V2	60





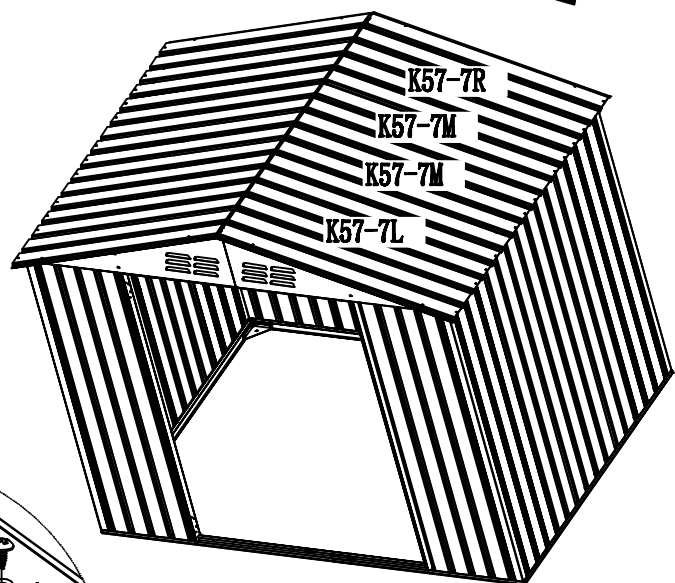
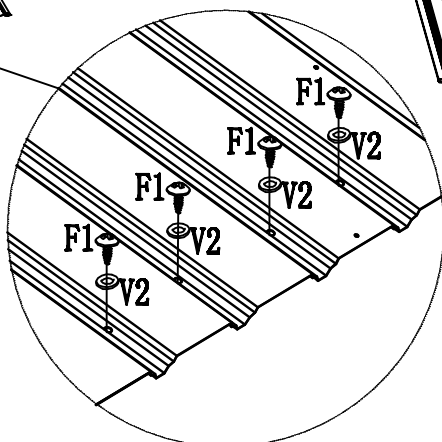
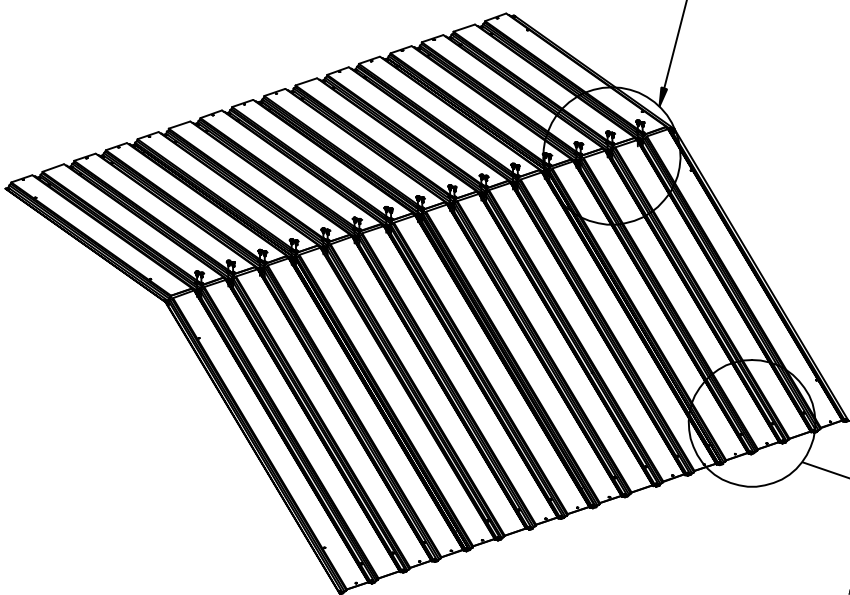
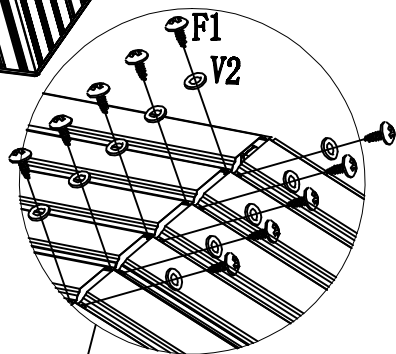
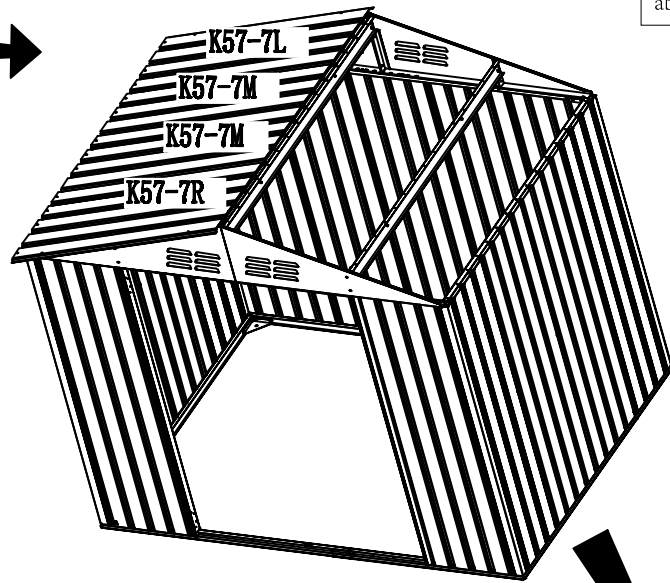
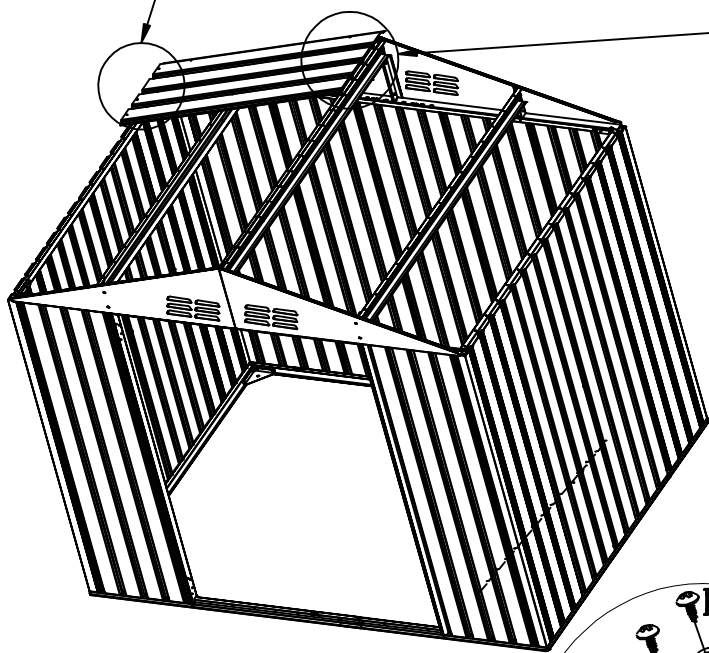

outside

Installation as shown in the illustration:
extend the edge outward about 50mm.

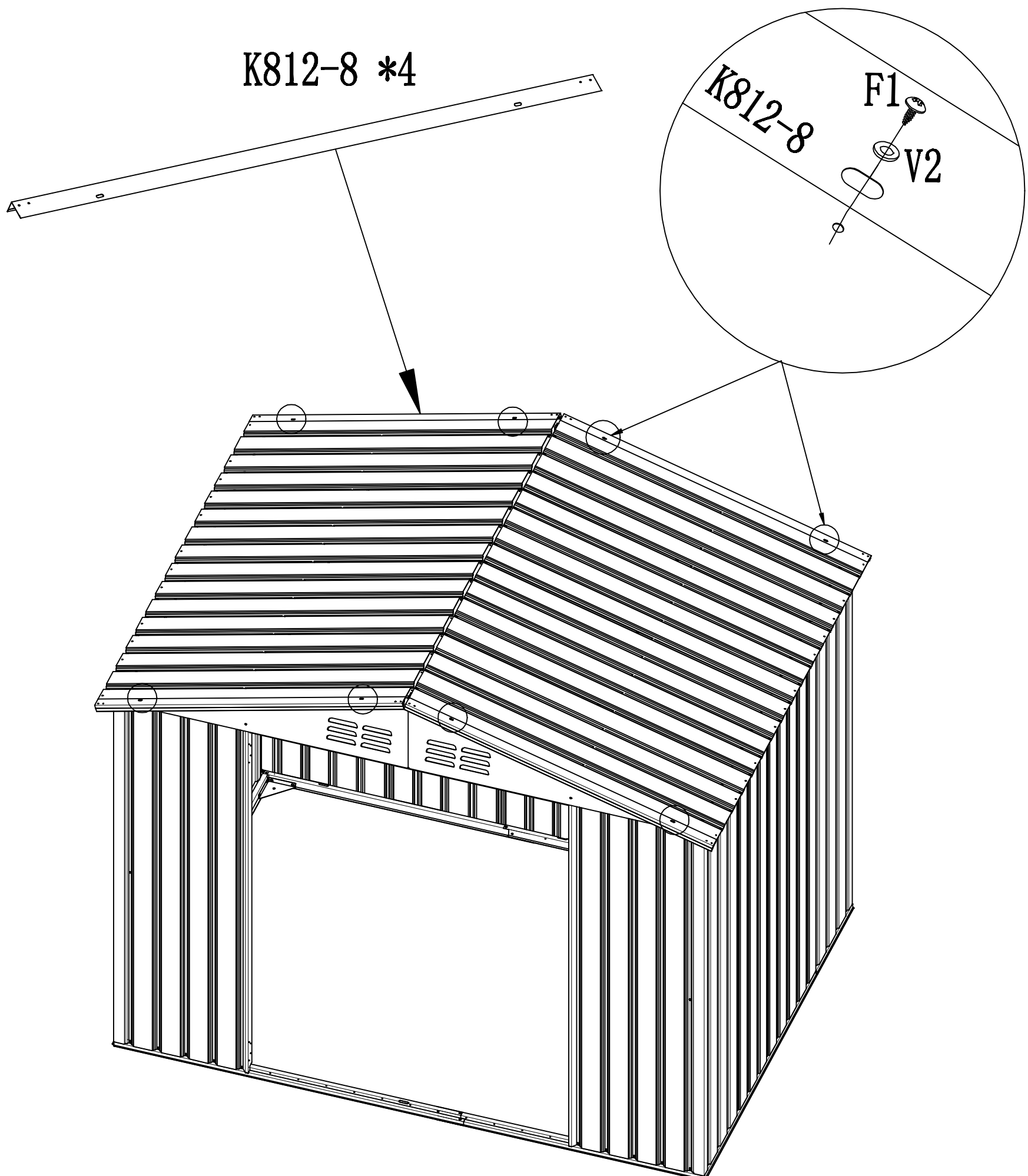





PART	NO.	QTY.
	K812-8	4
	F1	8
	V2	8

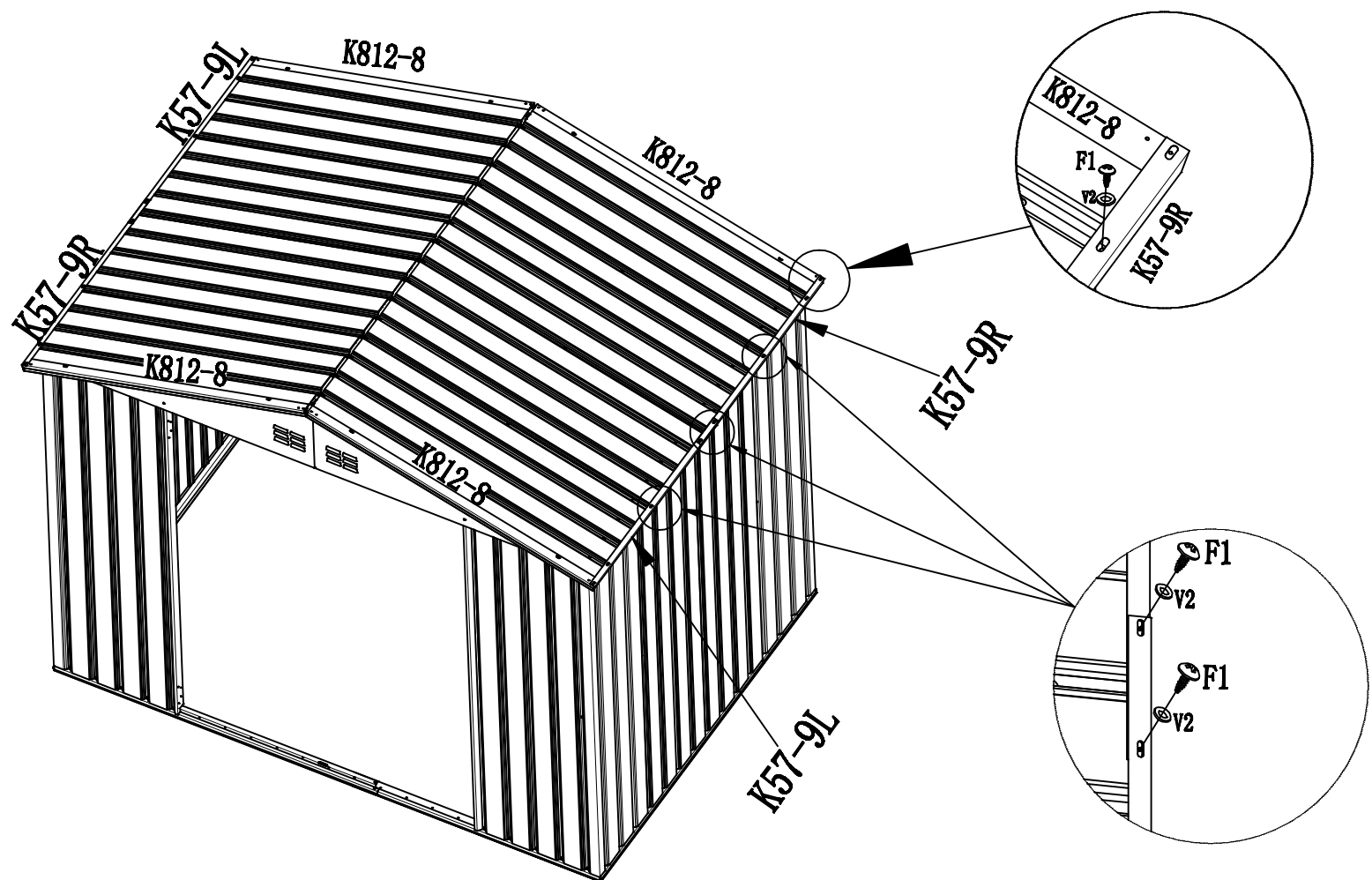
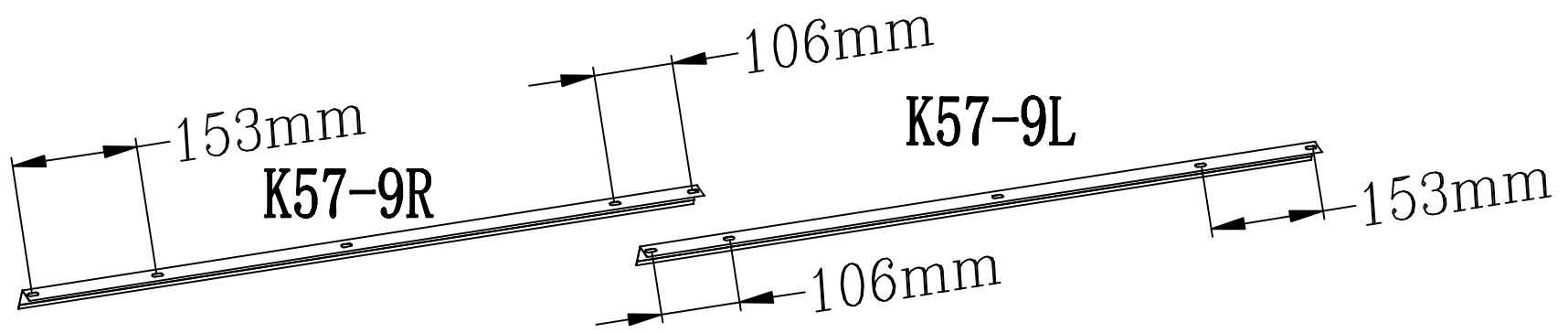

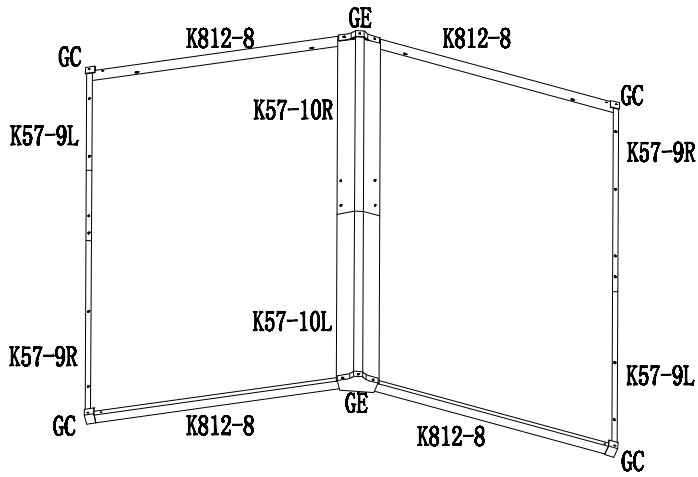
PART	NO.	QTY.
	K57-9L	2
	K57-9R	2
	F1	12
	V2	12







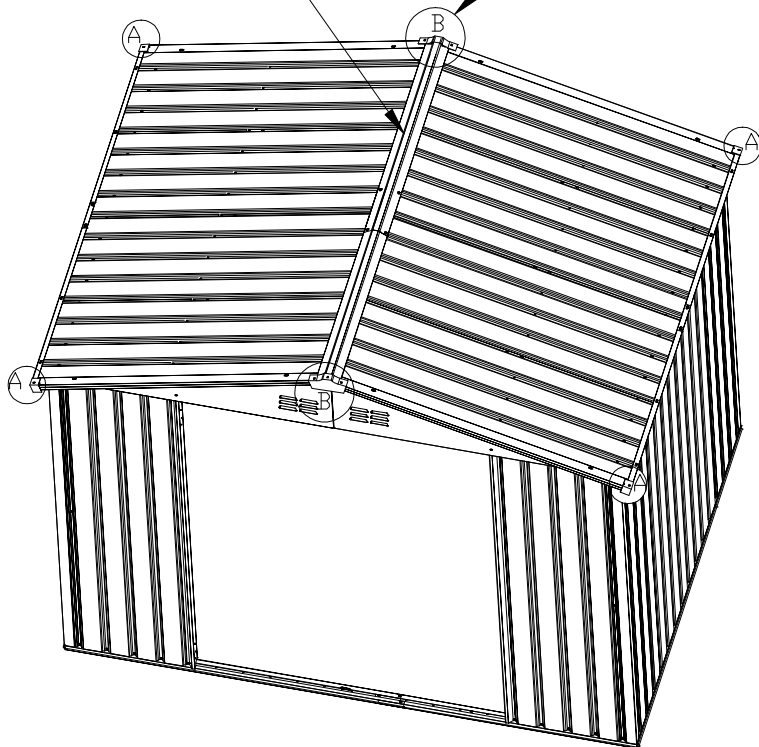
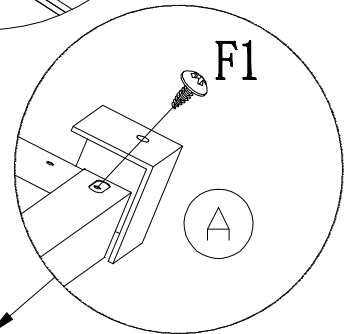
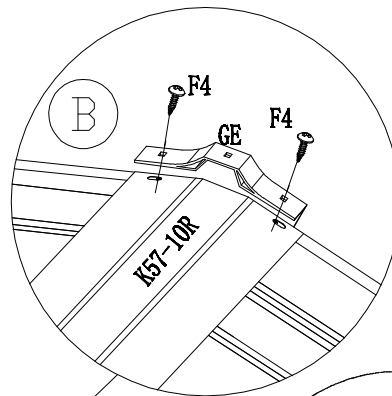
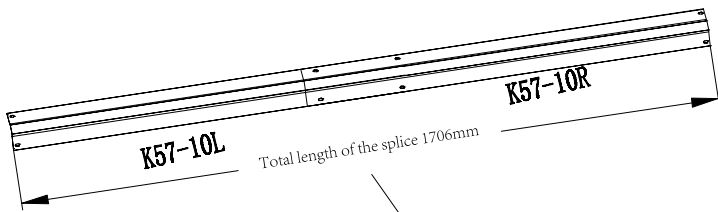

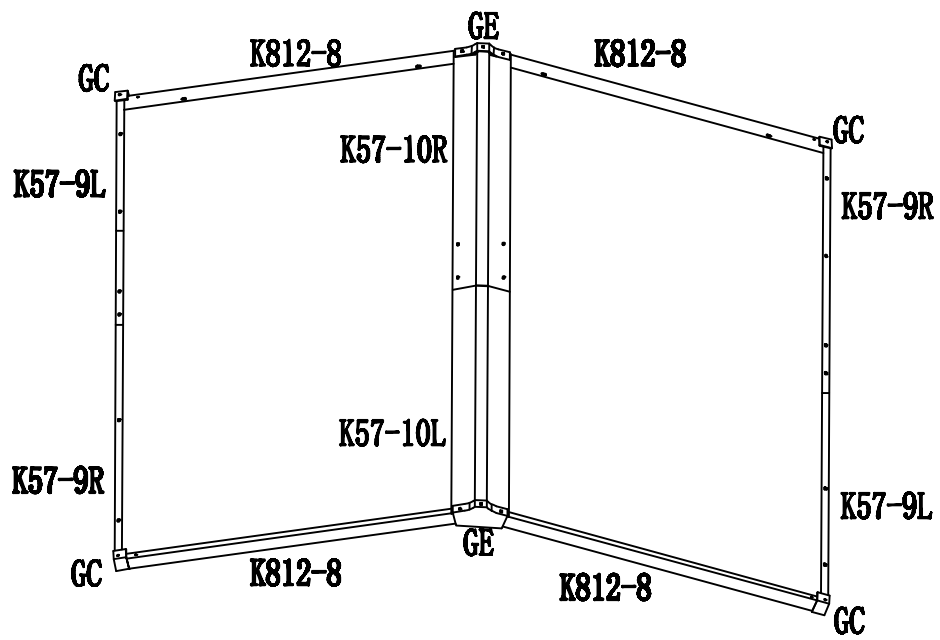
PART	NO.	QTY.
	GC	4
	GE	2
	F1	4
	F4	4





PART	NO.	QTY.
	GC	4
	GE	2
	F1	4
	F4	4
	V2	8

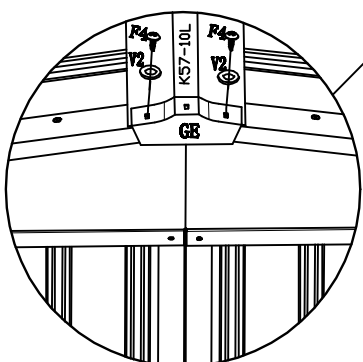
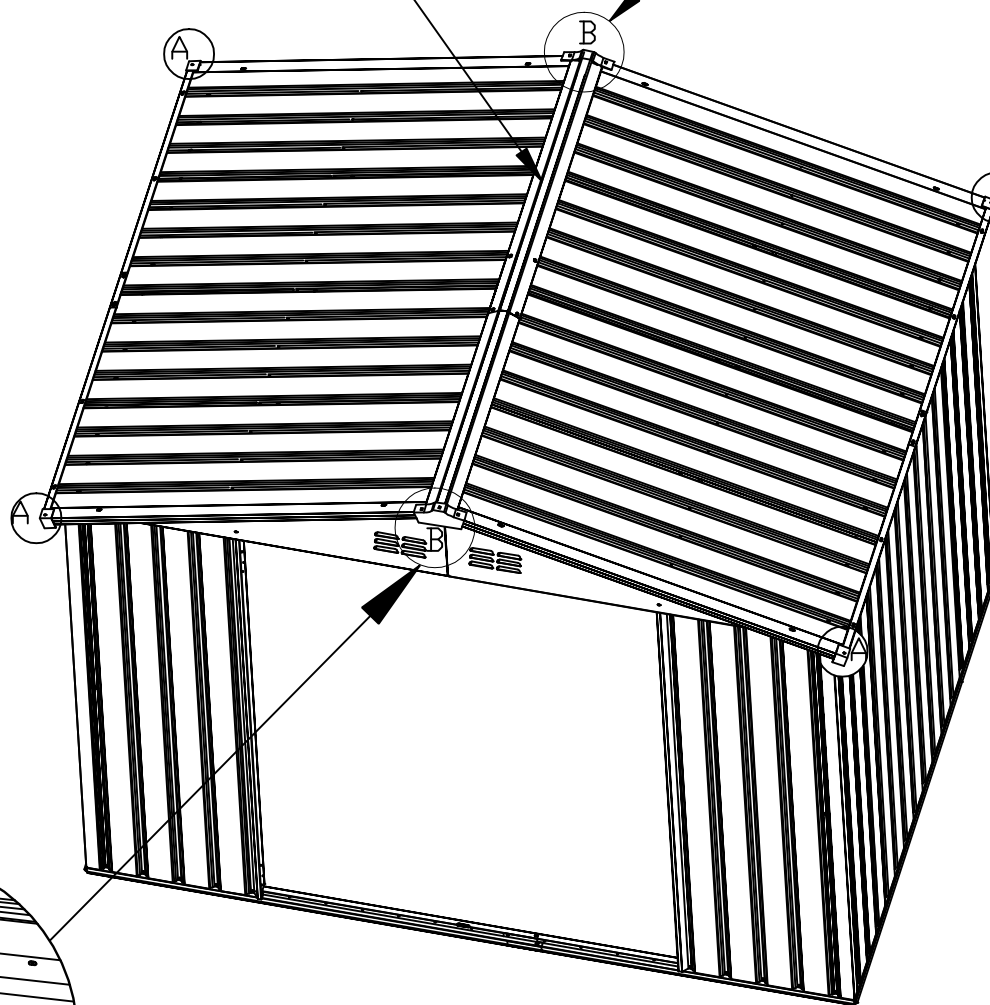
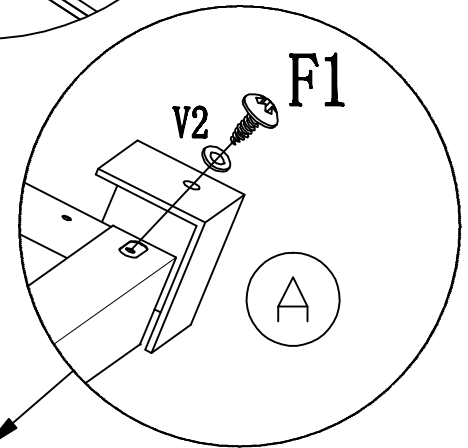
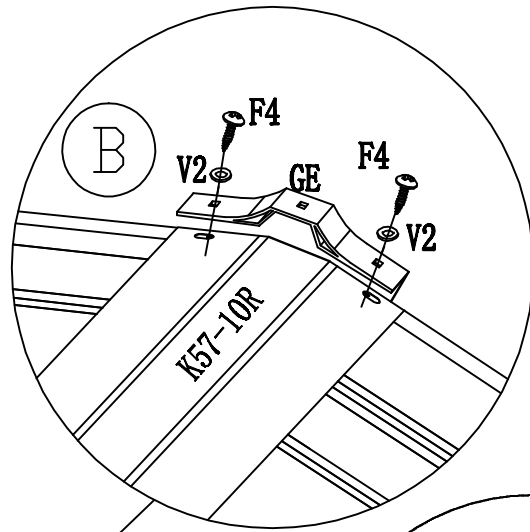
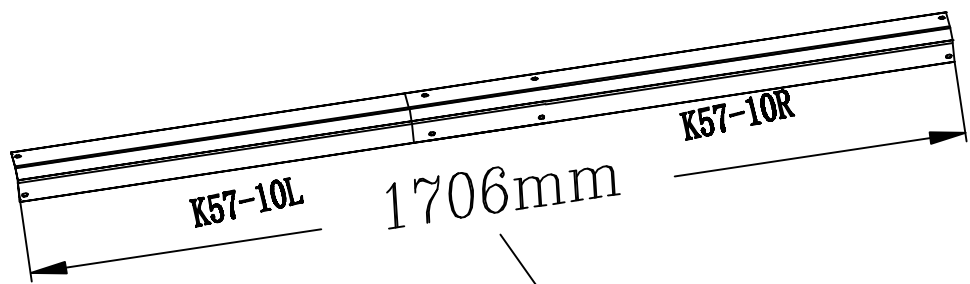

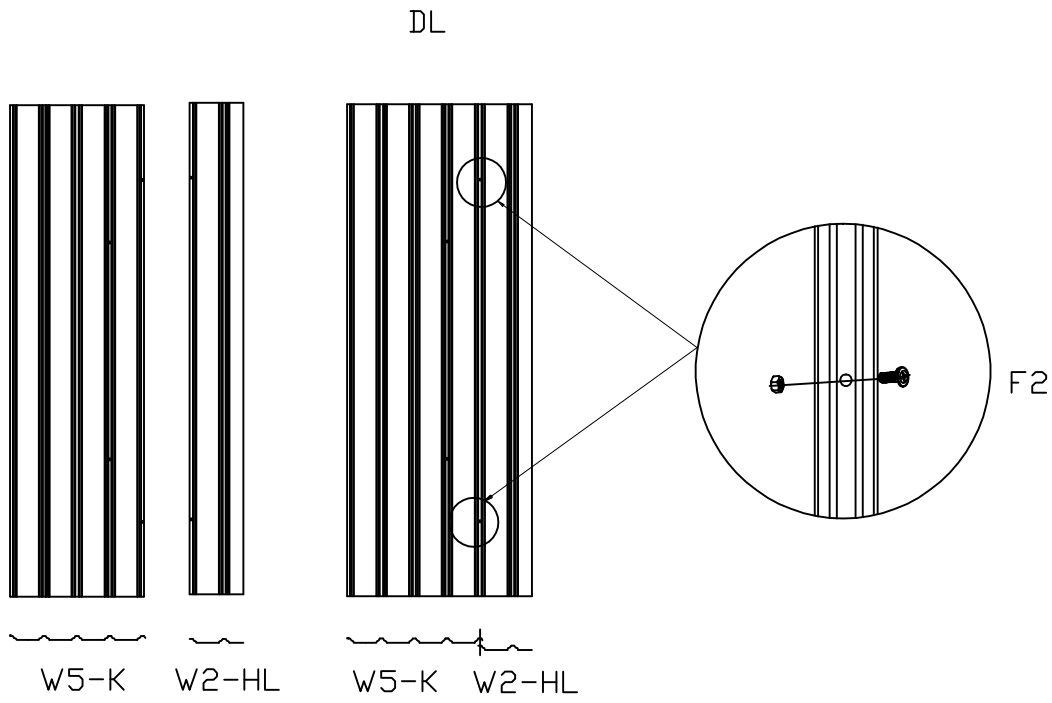

Left door panel splicing

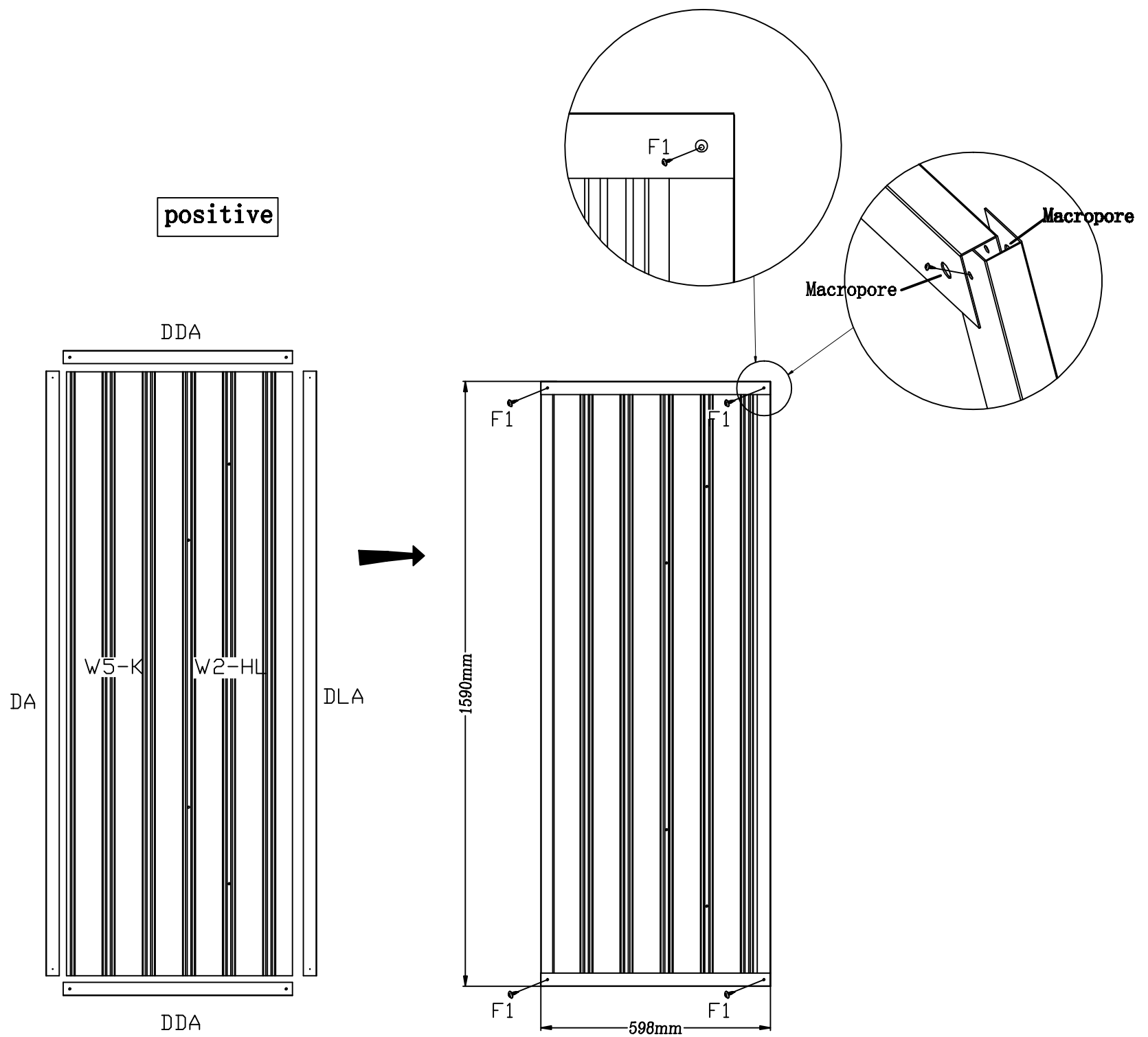

PART	NO.	QTY.
	W5-K	1
	W2-HL	1
	DA	1
	DLA	1
	DDA	2
	F1	4
	F2	2

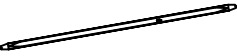

Left door panel splicing

PART	NO.	QTY.
	DBA	2
	F1	5
	F2	2

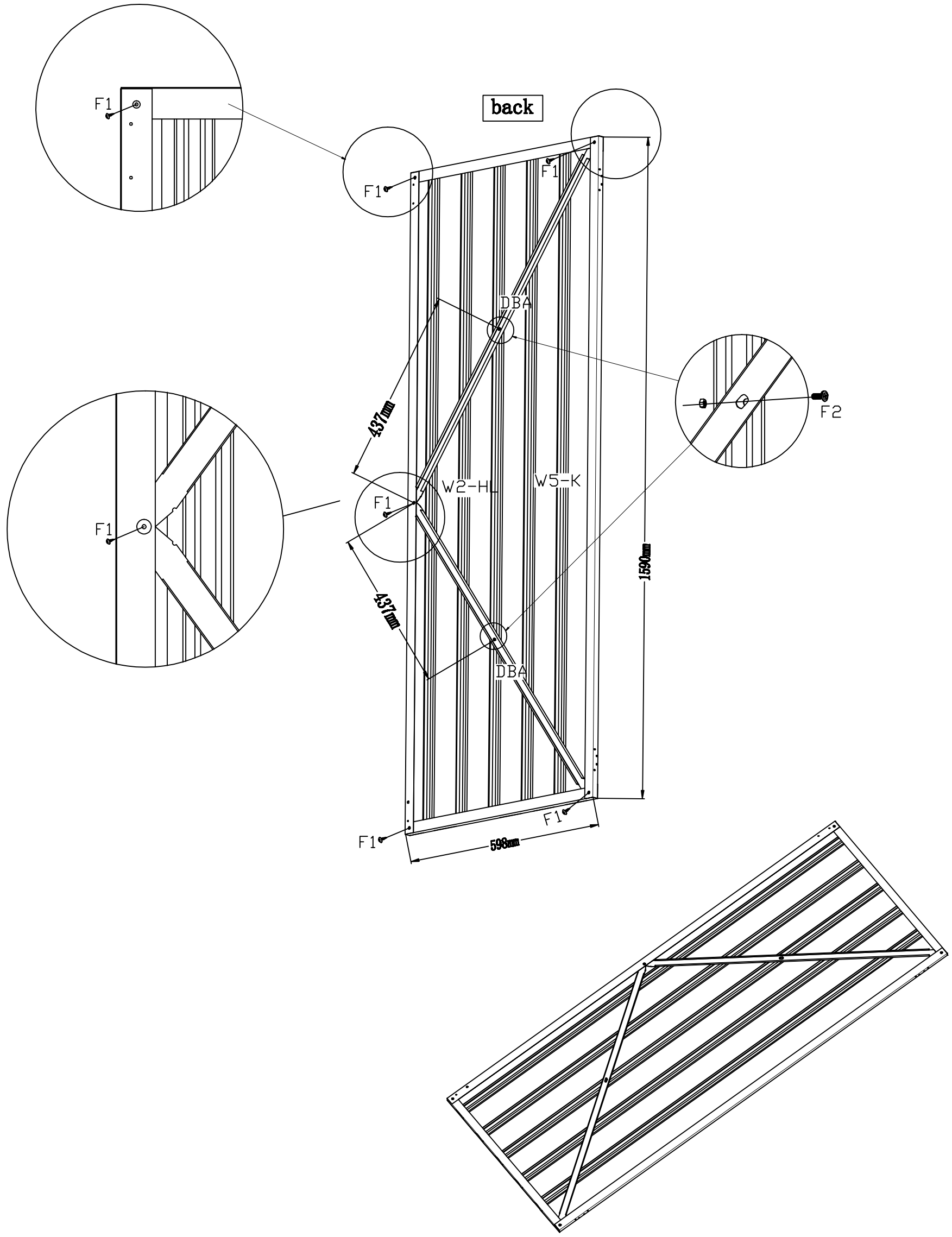

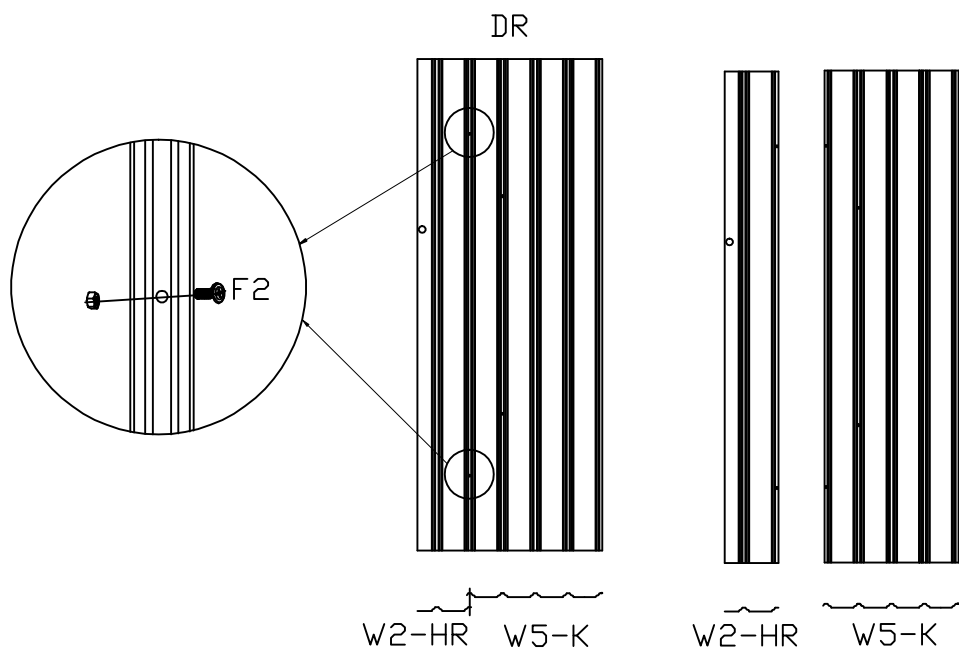

Right door panel splicing



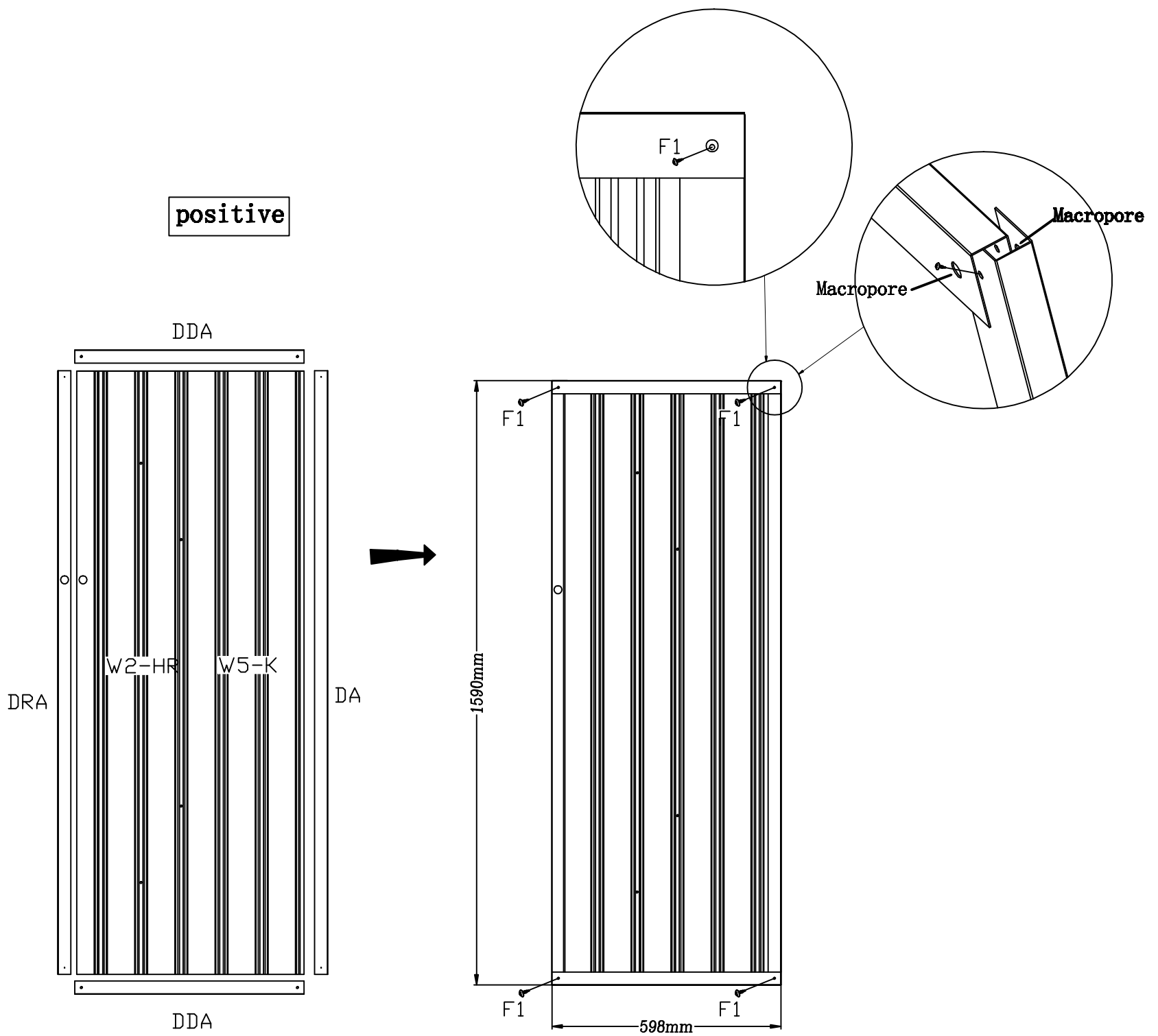

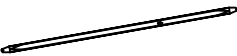

PART	NO.	QTY.
	W5-K	1
	W2-HR	1
	DA	1
	DRA	1
	DDA	2
	F1	4
	F2	2



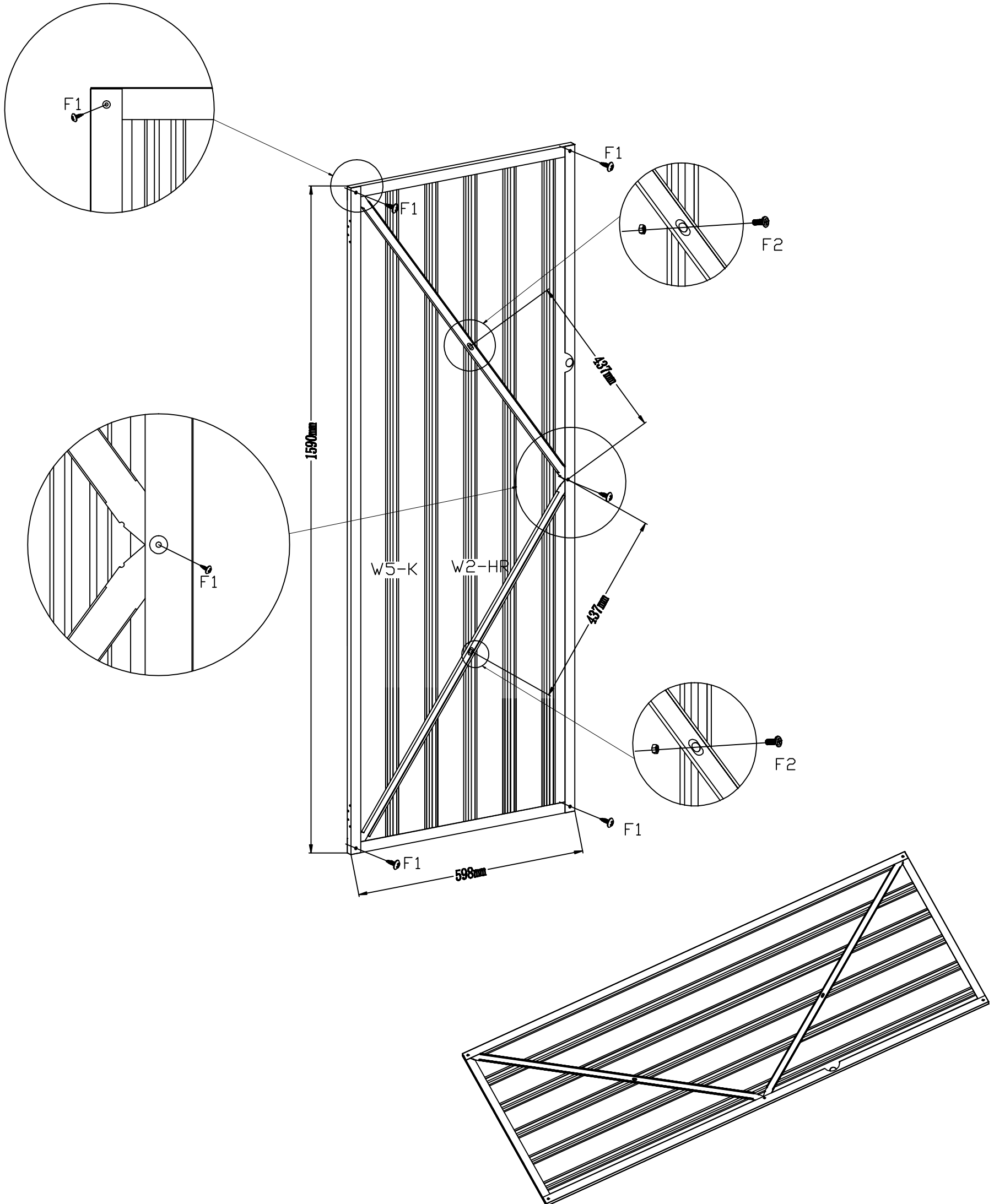

Right door panel splicing

PART	NO.	QTY.
	DBA	2
	F1	5
	F2	2

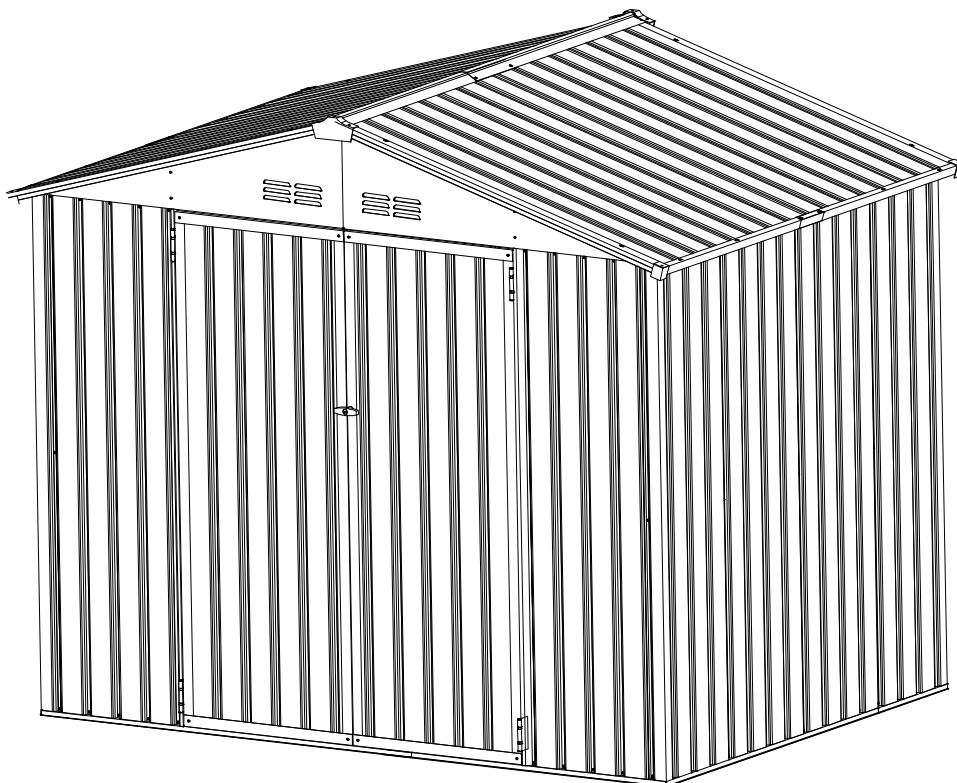
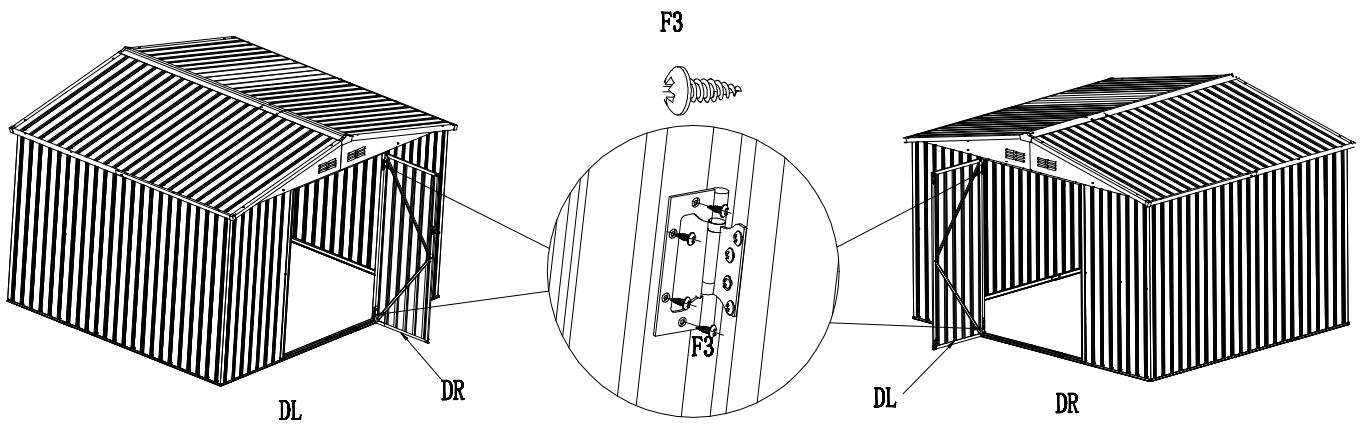

PART	NO.	QTY.
	DL	1
	DR	1
	F3	16



PART	NO.	QTY.
	SL	38

The exposed part of the assembly screw for the upper horizontal beam support rod C4 needs to be covered with a plastic protective cap.

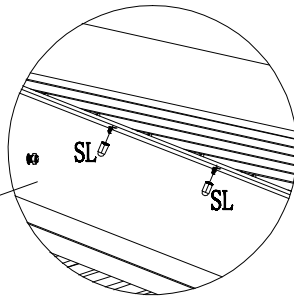
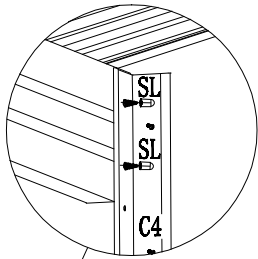

The exposed parts of the bolts for the assembly of the upper beam K58-6 and the top cover need to be covered with plastic protective caps.

