

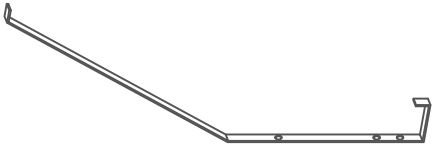





Assembly Instructions

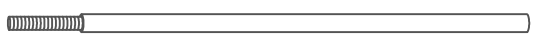
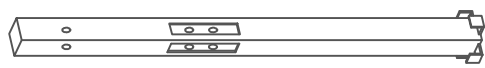
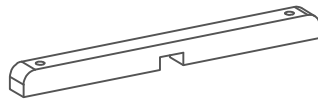
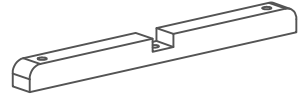

Parts List

Label	Picture	Qty
A		4
B		4
C		8
D		1
E		1
F		1

Hardware List

Label	Picture	Description	Size	Qty
H-1		Bolt	M6x15 mm	4
H-2		Bolt	M6x20 mm	9
H-3		Bolt	M6x40 mm	4

Tool List

Label	Picture	Description	Size	Qty
T-1		Allen Key	φ4 mm	1

Assembly Steps

ATTENTION:
DO NOT COMPLETELY TIGHTEN ANY SCREWS UNTIL ALL PARTS ARE IN PLACE

Step 1

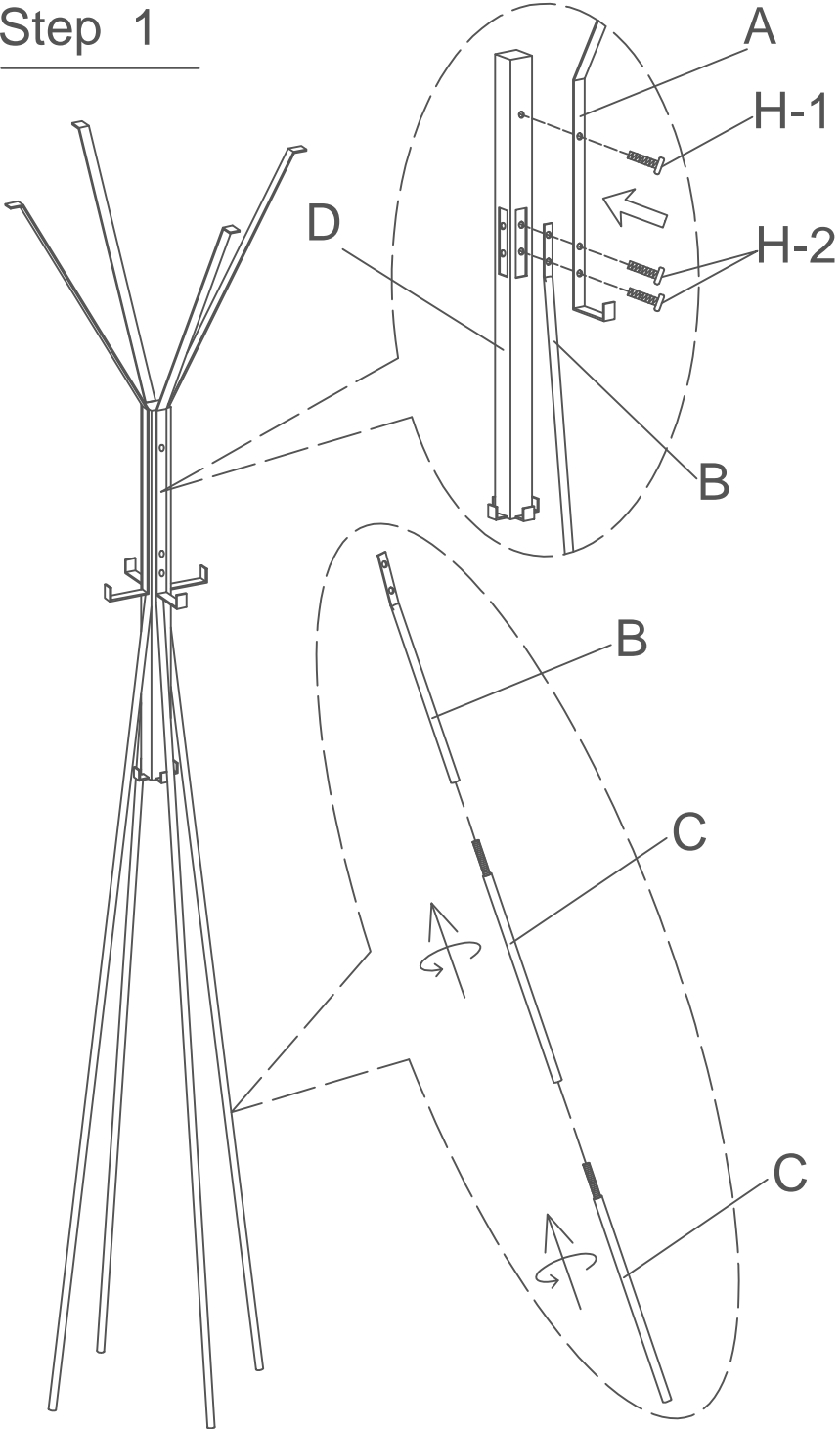

Step 3

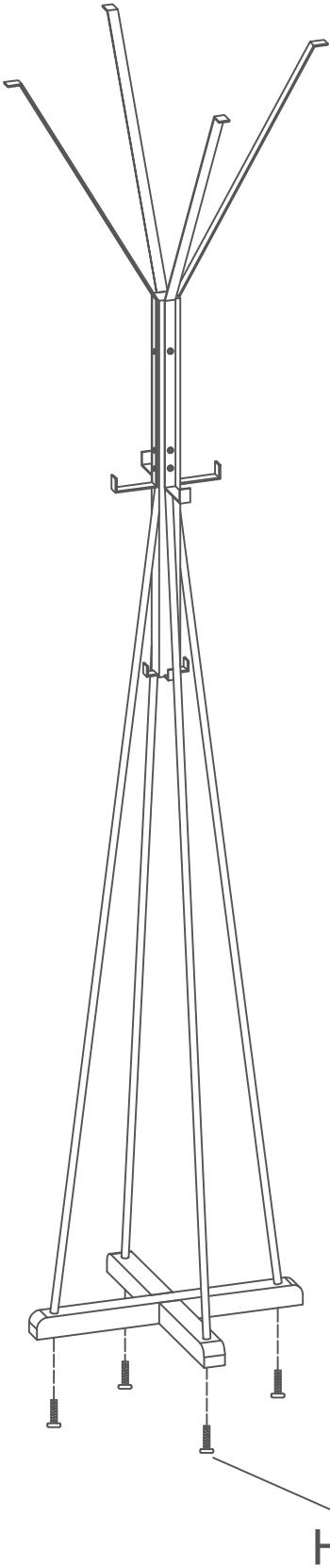

Step 2

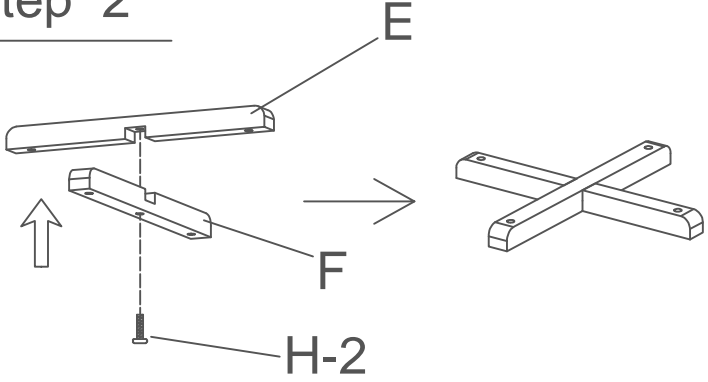

H-3