

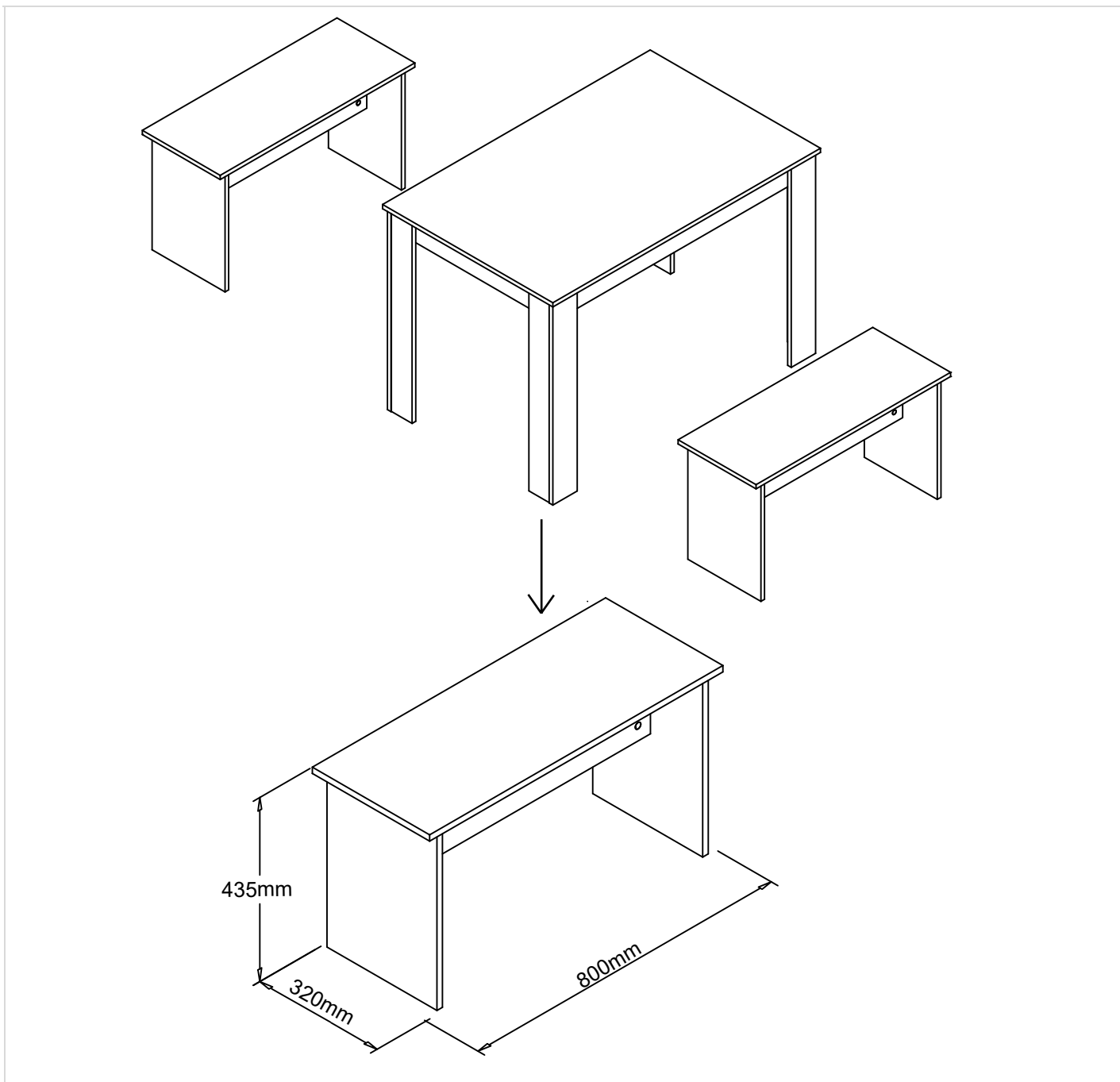

# TABLE WITH 2 BENCH SET

Assembly Instructions – Please keep for future reference



Dimensions	No. people	Assembly Time	
Width: 80cm Depth: 32cm Height: 43.5cm		20 mins (approx.)	

## Important

- PLEASE READ THESE INSTRUCTIONS FULLY BEFORE STARTING ASSEMBLY
- PLEASE DO NOT THROW THE PACKAGING AWAY UNTIL YOU ARE SATISFIED WITH PURCHASE, GOODS NEED TO BE RETURNED IN ORIGINAL PACKAGING.

# ⚠ Safety and Care Advice

**Important** – Please read these instructions fully before starting assembly

- Check you have all the components and tools listed on pages 4 and 5.
- Remove all fittings from the plastic bags and separate them into their groups.
- Keep children and animals away from the work area, small parts could choke if swallowed.
- Make sure you have enough space to lay out the parts before starting.
- Do not stand or put weight on the product, this could cause damage.
- Assemble the item as close to its final position (in the same room) as possible.
- Assemble on a soft, level surface to avoid damaging the unit or your floor.
- We do not recommend the use of power drill/drivers for inserting screws, as this could damage the unit. Only use hand screwdrivers.
- Dispose of all packaging carefully and responsibly.



## Care and Maintenance

- Only clean using a damp cloth and mild detergent, do not use bleach or abrasive cleaners.
- From time to time check that there are no loose screws on this unit.
- This product should not be discarded with household waste. Take to your local authority waste disposal centre.

## SPECIAL TIPS FOR FITTING CAM-LOCKS AND QUICKFIT

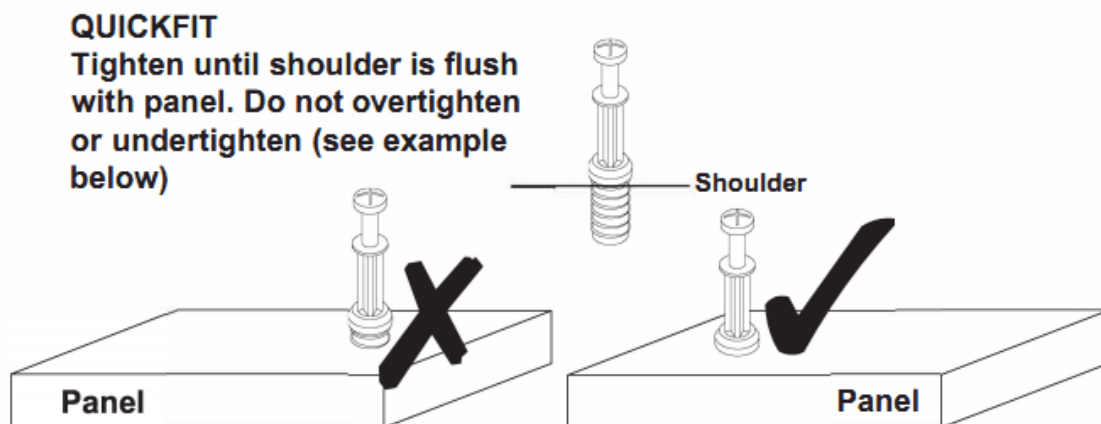
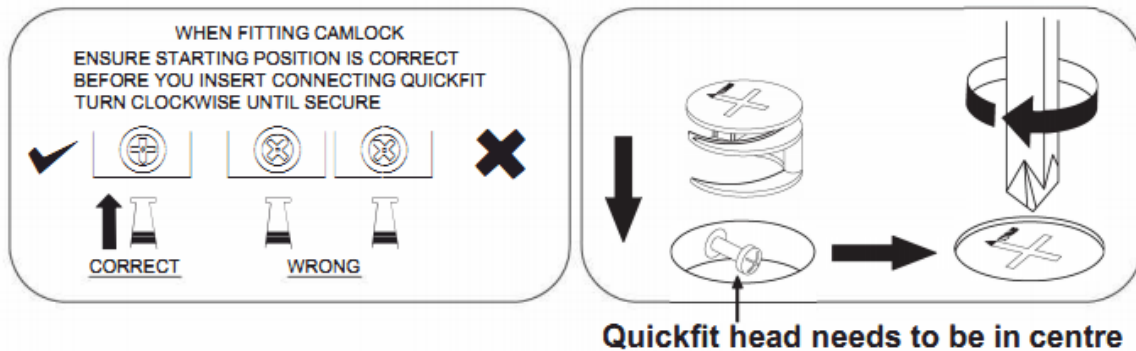

**If you are unhappy with the product and wish to return it, please follow the retailer's returns procedure.**

# Exploded View

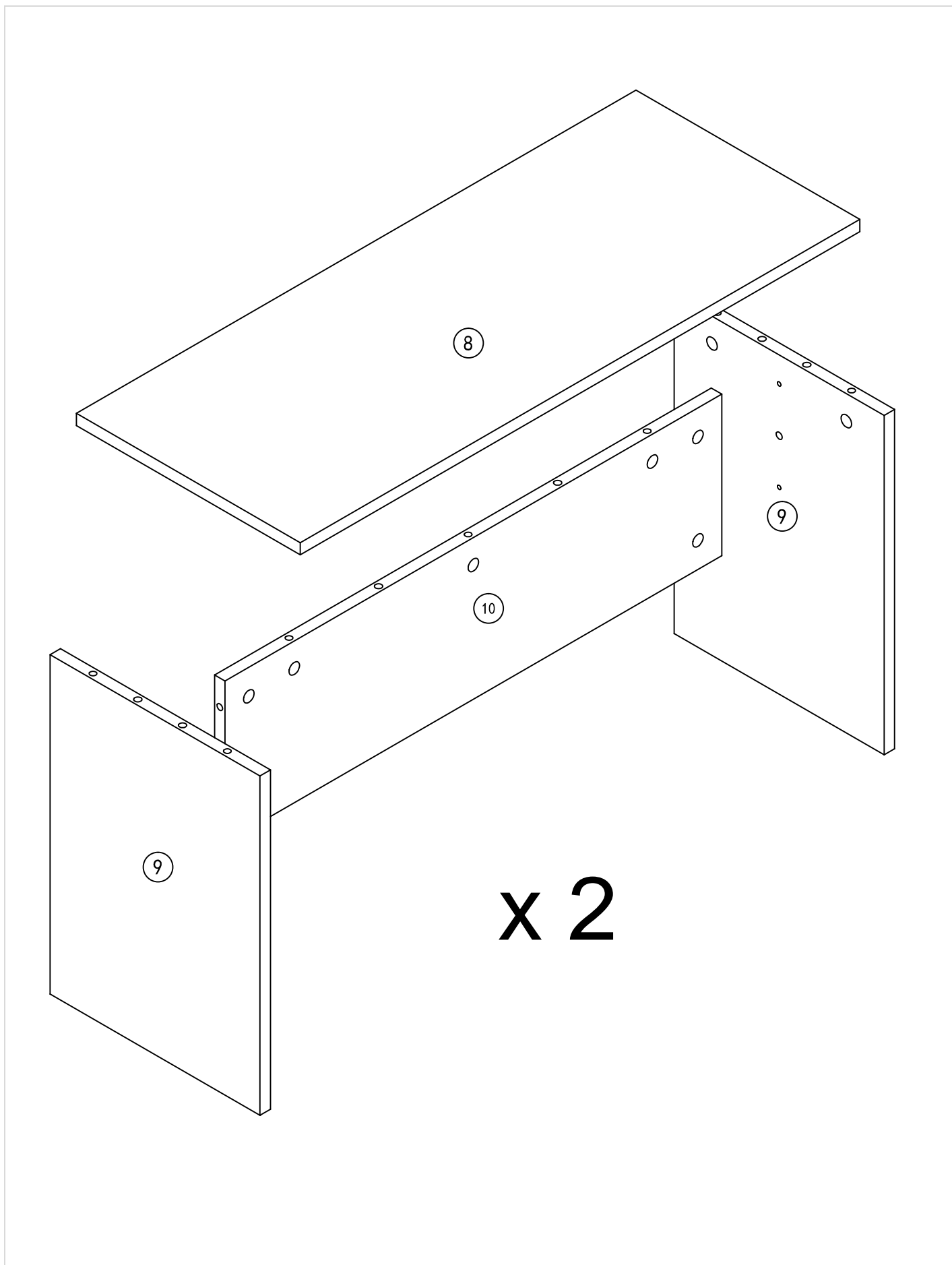







# Components - Fixings

**Please check that you have all the components listed below before constructing your item.**

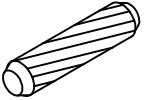
**Note:** The quantities below are the correct amount to complete the assembly. In some cases more fittings may be supplied than are required.

(A) X22		(B) X22		(C) X16		(D)	
(E)		(F) X8		(G)		(H)	
(I)		(J)		(K)		(L)	
(M)		(N)		(O)		(P)	
(Q)		(R)		(S)		(T)	
(U)		(V)		(W)		(X)	

## Tools Required

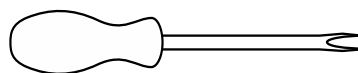
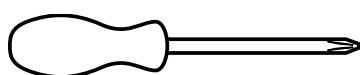

**Ruler** – Use this to measure your screws (mm)



**Important** – Please read these instructions fully before starting assembly

