

MODEL: IG10600150

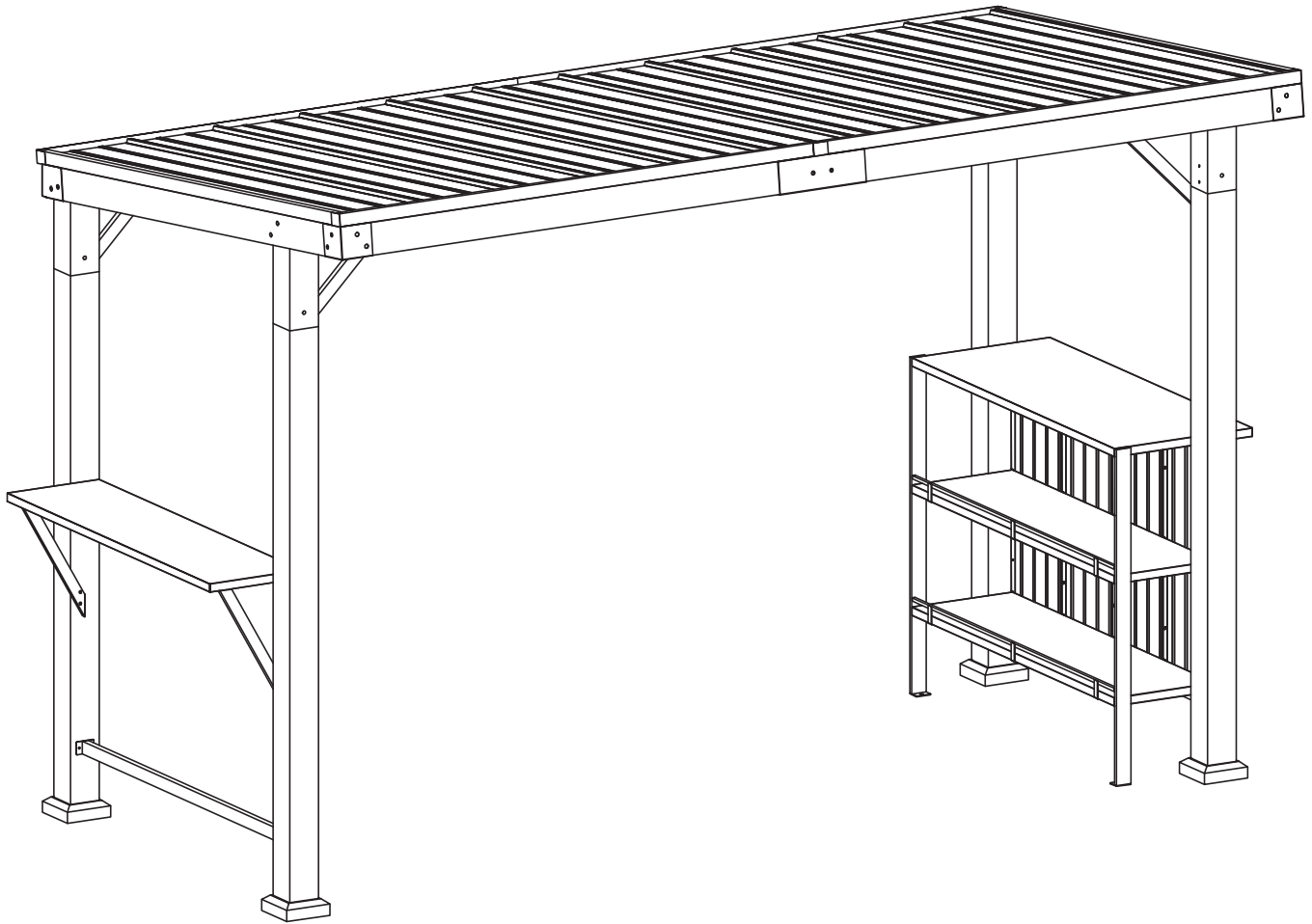

OWNER'S MANUAL

The Woodberry 6'x12' Cedar Framed Hard Top Gazebo

TABLE OF CONTENTS

ASSEMBLY GUIDE.....	02
USING YOUR PRODUCT.....	05

September 23, 2024

QUESTIONS?



E-mail: support@modernshade.org





Toll Free: 1-888-666-3070



Mon-Fri: 9:00 ---17:00 PST.

ASSEMBLY GUIDE

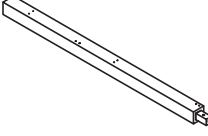
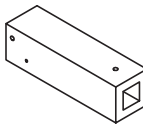
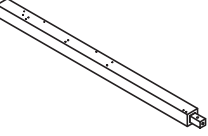
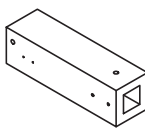
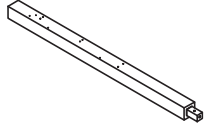
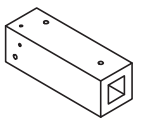
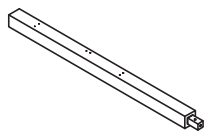
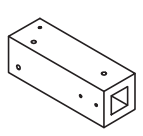
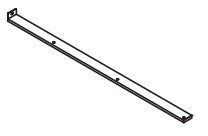
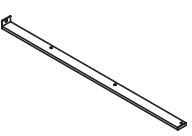
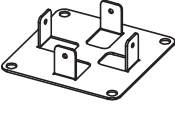
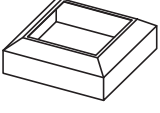
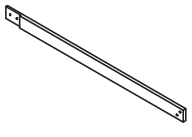
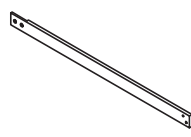
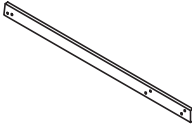
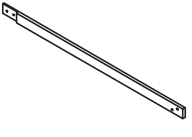
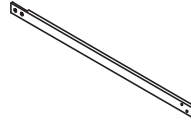
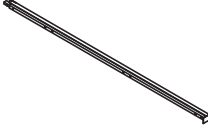
PARTS LIST

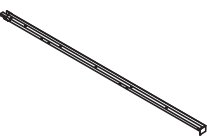
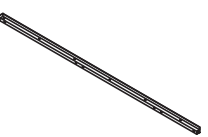
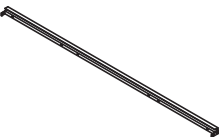
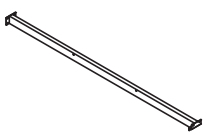
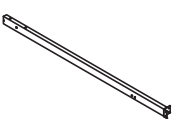
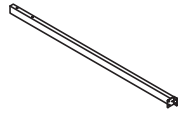
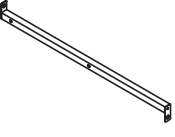
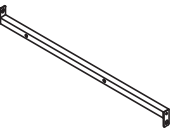
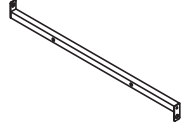
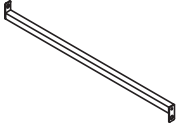
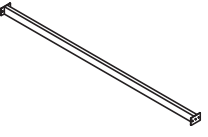
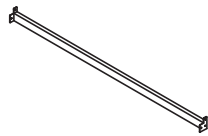
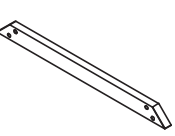
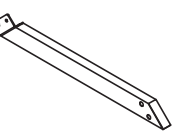
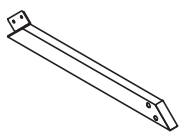
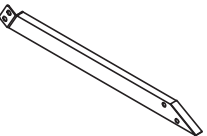
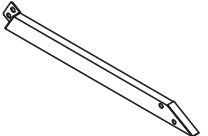
A1 Post 1 (1 piece) 	A2 Post 2 (1 piece) 	A3 Post 3 (1 piece) 	A4 Post 4 (1 piece) 	A5 Post 5 (1 piece) 	A6 Post 6 (1 piece) 
P000800905	P000800906	P000800907	P000800908	P000800909	P000800910
A7 Post 7 (1 piece) 	A8 Post 8 (1 piece) 	A9 Post 9 (1 piece) 	A10 Post 10 (1 piece) 	B Foot Base (4 pieces) 	C Foot Cover (4 pieces) 
P0008009101	P0008009102	P0008009103	P0008009104	P0008009105	P0008009106
D1 Cross Beam 1 (1 piece) 	D2 Cross Beam 2 (1 piece) 	D3 Cross Beam 3 (2 pieces) 	D4 Cross Beam 4 (1 piece) 	D5 Cross Beam 5 (1 piece) 	E1 Roof Border 1 (1 piece) 
P0008009107	P0008009108	P0008009109	P0008009110	P0008009111	P0008009112
E2 Roof Border 2 (1 piece) 	E3 Roof Border 3 (1 piece) 	E4 Roof Border 4 (1 piece) 	E5 Roof Border 5 (2 pieces) 	F Roof Rib (4 pieces) 	G1 Reinforced Beam 1 (1 piece) 
P0008009113	P0008009114	P0008009115	P0008009116	P0008009117	P0008009118
G2 Reinforced Beam 2 (1 piece) 	H1 Roof Support 1 (2 pieces) 	H2 Roof Support 2 (2 pieces) 	H3 Roof Support 3 (1 piece) 	H4 Roof Support 4 (5 pieces) 	J1 Bottom Cross Beam 1 (1 piece) 
P0008009119	P0008009120	P0008009121	P0008009122	P0008009123	P0008009124
J2 Bottom Cross Beam 2 (1 piece) 	K1 Support Bracket 1 (2 pieces) 	K2 Support Bracket 2 (1 piece) 	K3 Support Bracket 3 (1 piece) 	K5 Support Bracket 4 (1 piece) 	K6 Support Bracket 5 (1 piece) 
P0008009125	P0008009126	P0008009127	P0008009128	P0008009129	P0008009130

ASSEMBLY INSTRUCTIONS

•Please carefully unpack each of the components and hardware. check the components against the parts list and make sure there are no missing parts. lay pieces on cardboard or a soft mat to help protect the pieces from scratches.

⚠ CAUTION

Watch for sharp edges when handling the pieces, wear gloves to avoid injury.

- For ease of assembly, it is recommended to have 3 or more people and allow enough time to completely finish the assembly. assembly can take 6-8 hours. a step-ladder is required for assembly (not included).
- Follow step by step instructions, and follow all safety warnings provided with your tools.
- DO NOT tighten screws until all the screws and washers are properly installed. tighten screws securely, do not over tighten.
- Gazebo should not be used in inclement weather and high winds.

STEP 01 Slide one (1) Foot Cover **C** onto the bottom of Post 1 **A1**. Attach one (1) Foot Base **B** to the bottom of the post using one (1) M5*20 Bolt **AA** on each side. Then, slide the Foot Cover **C** down over the foot base. Repeat for Post 3 **A3**, Post 5 **A5**, and Post 7 **A7**.

AA x 16

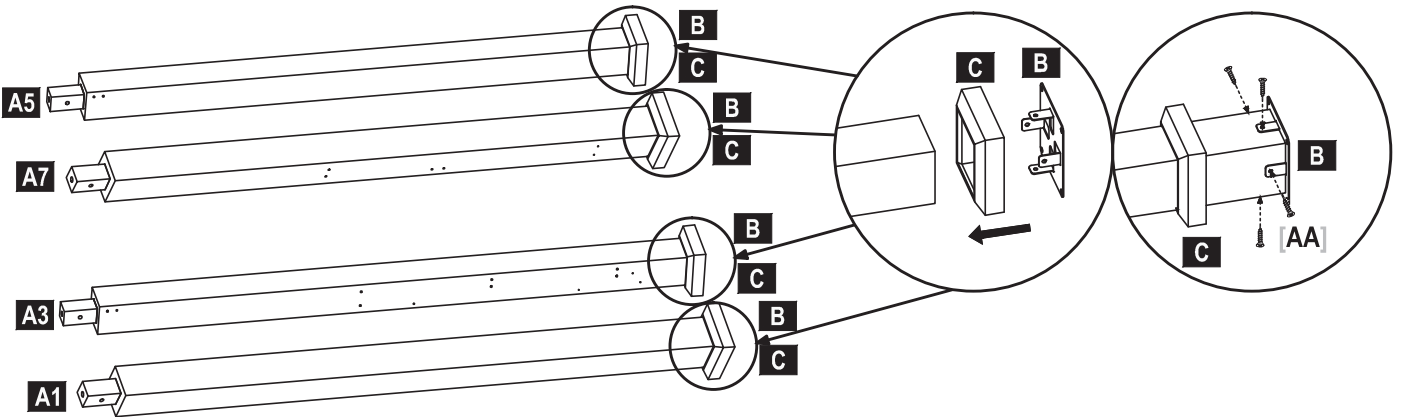

STEP 02 Place one (1) Post 2 **A2** on top of Post 1 **A1** with the single hole in line with the hole on the top of the post. Place one (1) M10 Flat Washer **UU** onto one (1) M10*115 Bolt **KK**, then slide it through the single hole. Place one (1) M10 Flat Washer **UU** and one (1) M10 Anti-Slip Screw Nut **NN** on the other end and secure it. Then, insert two (2) M10*65 Bolts **CC** with two (2) M10 Flat Washers **UU** into the holes on the side.

Repeat assembly steps to attach Post 3 **A3** to Post 4 **A4**, Post 5 **A5** to Post 6 **A6**, and Post 7 **A7** to Post 8 **A8**.

CC x 8
KK x 4
NN x 4
UU x 16

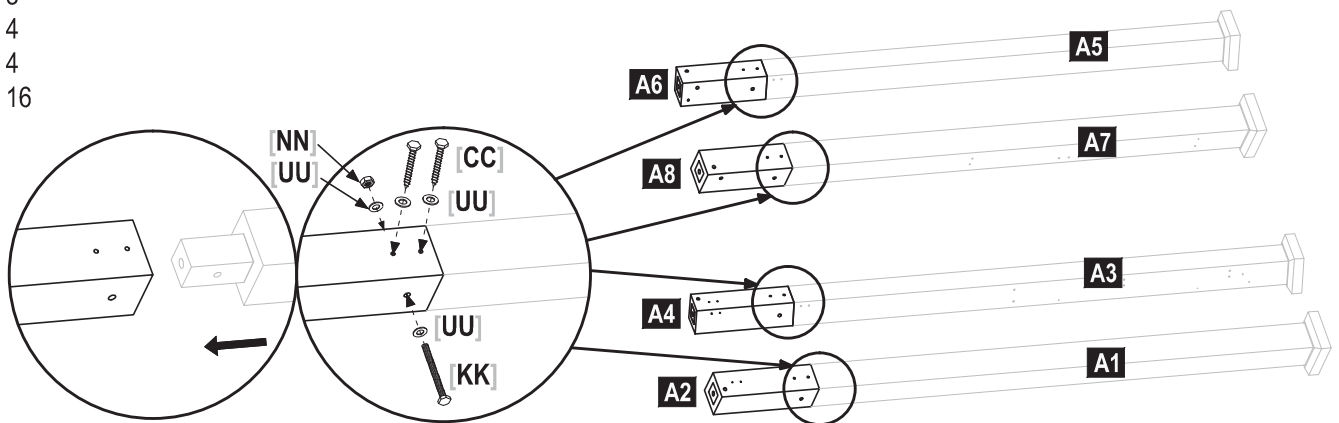

STEP 03 Stand up the posts. Line up Post 2 **A2** to Post 8 **A8** using one (1) Cross Beam 3 **D3** and one (1) Connector 4 **L4** over the end of Post 8. Then, secure the assembly with one (1) M10*65 Bolt **CC** with one (1) M10 Flat Washer **UU** in the outer hole and one (1) M10*140 Bolt **LL** with one (1) M10 Flat Washer **UU**. On the other end of the bolt, add one (1) M10 Flat Washer **UU** and one (1) M10 Anti-Slip Screw Nut **NN**.

Run another Cross Beam 1 **D3** between Post 4 **A4** and Post 6 **A6** covering the corner with one (1) Connector 3 **L3**. Then, secure the assembly with one (1) M10*65 Bolt **CC** with one (1) M10 Flat Washer **UU** in the outer hole and one (1) M10*140 Bolt **LL** with one (1) M10 Flat Washer **UU**. On the other end of the bolt, add one (1) M10 Flat Washer **UU** and one (1) M10 Anti-Slip Screw Nut **NN**.

- CC** x 4
- LL** x 4
- NN** x 4
- UU** x 12

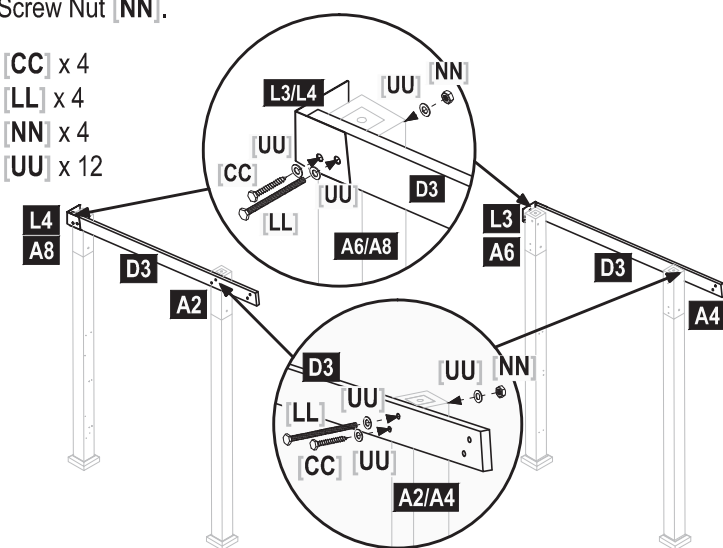

STEP 04 Align the ends of Cross Beam 2 **D2** and Cross Beam 1 **D1**. Over each hole, place one (1) M8*8 Four-Claw Screw Nut **QQ**. Then, cover the holes with one (1) Connector 5 **L5**. Secure with two (2) M8*30 Bolts **HH** and two (2) M8 Flat Washers **TT** on the side. On the top, fill the four (4) holes with four (4) M5*20 Bolts **AA**.

- AA** x 4
- HH** x 2
- TT** x 2
- QQ** x 2

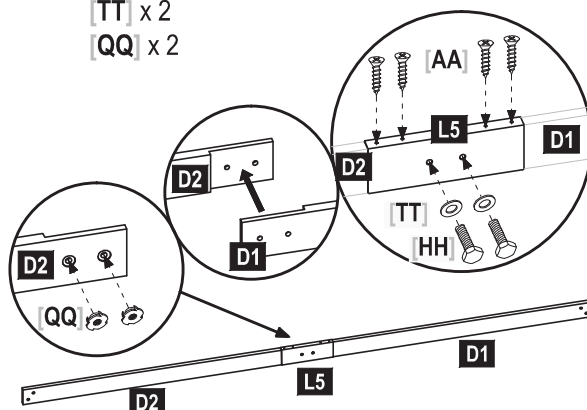

STEP 05 Align the ends of Cross Beam 4 **D4** and Cross Beam 5 **D5**. Over each hole, place one (1) M8*8 Four-Claw Screw Nut **QQ**. Then, cover the holes with one (1) Connector 6 **L6**. Secure with two (2) M8*30 Bolts **HH** and two (2) M8 Flat Washers **TT** on the side. On the top and bottom, fill the eight (8) holes with eight (8) M5*20 Bolts **AA**.

STEP 06 Connect the Cross Beam assembly from Step 4 to the side of the gazebo with a Connector 1 **L1** on the inside and a Connector 2 **L2** on the outside. Insert two (2) M10*40 Bolts **JJ** with M10 Flat Washers **UU** on each side and secure with two (2) M10 Flat Washers **UU** and two (2) M10 Anti-Slip Screw Nuts **NN** on the inside. Below the corner, secure the corner with two (2) M5*20 Bolts **AA**.

- AA** x 4
- JJ** x 8
- NN** x 8
- UU** x 16

